

CD4018BM/CD4018BC Presettable Divide-by-N Counter

General Description

The CD4018B consists of 5 Johnson counter stages. A buffered \bar{Q} output from each stage, "CLOCK", "RESET", "DATA", "PRESET ENABLE", and 5 individual "JAM" inputs are provided. The counter is advanced one count at the positive clock signal transition. A high "RESET" signal clears the counters to an "ALL ZERO" condition. A high "PRESET ENABLE" signal allows information on the "JAM" inputs to preset the counter. Anti-lock gating is provided to assure the proper counting sequence.

Features

- Wide supply voltage range 3.0V to 15V
- High noise immunity 0.45 V_{DD} (typ.)
- Low power TTL fan out of 2 driving 74L compatibility or 1 driving 74LS
- Fully static operation

Applications

- Fixed and programmable divide-by-10, 9, 8, 7, 6, 5, 4, 3, 2 counter
- Fixed and programmable counters greater than 10
- Programmable decade counters
- Divide by "N" counters/frequency synthesizers

Logic Diagram

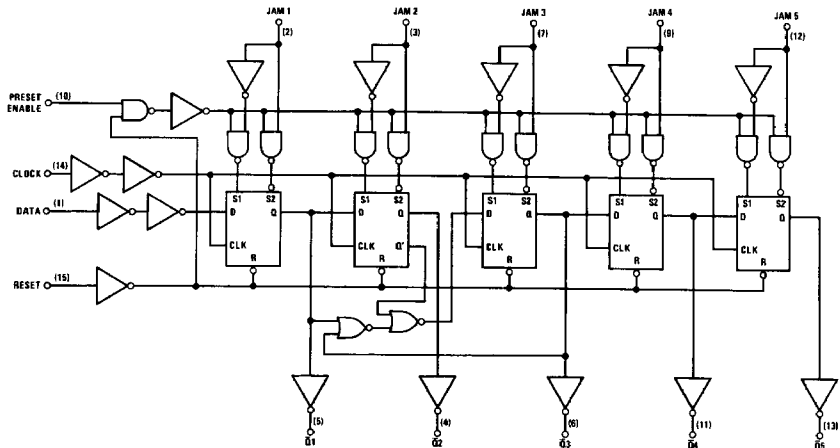

TL/F/5951-1

Connection Diagram

Dual-In-Line Package

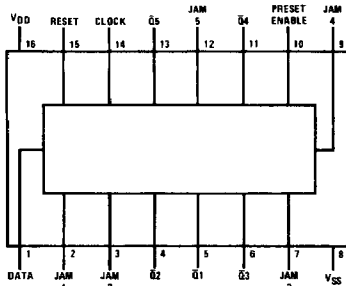

Top View

TL/F/5951-2

Order Number CD4018B*

*Please look into Section 8, Appendix D for availability of various package types.

Absolute Maximum Ratings (Notes 1 & 2)

If Military/Aerospace specified devices are required, contact the National Semiconductor Sales Office/Distributors for availability and specifications.

DC Supply Voltage (V_{DD})	-0.5V to +18 V _{DC}
Input Voltage (V_{IN})	-0.5 to V_{DD} + 0.5 V _{DC}
Storage Temperature Range (T_S)	-65°C to +150°C
Power Dissipation (P_D)	
Dual-In-Line	700 mW
Small Outline	500 mW
Lead Temperature (T_L)	
(Soldering, 10 seconds)	300°C

Recommended Operating Conditions (Note 2)

Supply Voltage (V_{DD})	3V to 15 V _{DC}
Input Voltage (V_{IN})	0V to V_{DD} V _{DC}
Operating Temperature Range (T_A)	
CD4018BM	-55°C to +125°C
CD4018BC	-40°C to +85°C

DC Electrical Characteristics CD4018BM (Note 2)

Symbol	Parameter	Conditions	-55°C		+25°C			+125°C		Units
			Min	Max	Min	Typ	Max	Min	Max	
I_{DD}	Quiescent Device Current	$V_{DD} = 5V, V_{IN} = V_{DD}$ or V_{SS}		5		0.3	5		150	μA
		$V_{DD} = 10V, V_{IN} = V_{DD}$ or V_{SS}		10		0.5	10		300	μA
		$V_{DD} = 15V, V_{IN} = V_{DD}$ or V_{SS}		20		1.0	20		600	μA
V_{OL}	Low Level Output Voltage	$ I_O < 1 \mu A$ $V_{DD} = 5V$		0.05		0	0.05		0.05	V
		$V_{DD} = 10V$		0.05		0	0.05		0.05	V
		$V_{DD} = 15V$		0.05		0	0.05		0.05	V
V_{OH}	High Level Output Voltage	$ I_O < 1 \mu A$ $V_{DD} = 5V$	4.95		4.95	5		4.95		V
		$V_{DD} = 10V$	9.95		9.95	10		9.95		V
		$V_{DD} = 15V$	14.95		14.95	15		14.95		V
V_{IL}	Low Level Input Voltage	$V_{DD} = 5V, V_O = 0.5V$ or 4.5V		1.5		2.25	1.5		1.5	V
		$V_{DD} = 10V, V_O = 1V$ or 9V		3.0		4.5	3.0		3.0	V
		$V_{DD} = 15V, V_O = 1.5V$ or 13.5V		4.0		6.75	4.0		4.0	V
V_{IH}	High Level Input Voltage	$V_{DD} = 5V, V_O = 0.5V$ or 4.5V	3.5		3.5	2.75		3.5		V
		$V_{DD} = 10V, V_O = 1V$ or 9V	7.0		7.0	5.5		7.0		V
		$V_{DD} = 15V, V_O = 1.5V$ or 13.5V	11.0		11.0	8.25		11.0		V
I_{OL}	Low Level Output Current (Note 3)	$V_{DD} = 5V, V_O = 0.4V$	0.64		0.51	0.88		0.36		mA
		$V_{DD} = 10V, V_O = 0.5V$	1.6		1.3	2.25		0.9		mA
		$V_{DD} = 15V, V_O = 1.5V$	4.2		3.4	8.8		2.4		mA
I_{OH}	High Level Output Current (Note 3)	$V_{DD} = 5V, V_O = 4.6V$	-0.64		-0.51	-0.88		-0.36		mA
		$V_{DD} = 10V, V_O = 9.5V$	-1.6		-1.3	-2.25		-0.9		mA
		$V_{DD} = 15V, V_O = 13.5V$	-4.2		-3.4	-8.8		-2.4		mA
I_{IN}	Input Current	$V_{DD} = 15V, V_{IN} = 0V$		-0.1		-10^{-5}	-0.1		-1.0	μA
		$V_{DD} = 15V, V_{IN} = 15V$		0.1		10^{-5}	0.1		1.0	μA

DC Electrical Characteristics CD4018BC (Note 2)

Symbol	Parameter	Conditions	-40°C		+25°C			+85°C		Units
			Min	Max	Min	Typ	Max	Min	Max	
I_{DD}	Quiescent Device Current	$V_{DD} = 5V, V_{IN} = V_{DD}$ or V_{SS}		20		0.5	20		150	μA
		$V_{DD} = 10V, V_{IN} = V_{DD}$ or V_{SS}		40		1.0	40		300	μA
		$V_{DD} = 15V, V_{IN} = V_{DD}$ or V_{SS}		80		5.0	80		600	μA
V_{OL}	Low Level Output Voltage	$ I_O < 1 \mu A$ $V_{DD} = 5V$		0.05		0	0.05		0.05	V
		$V_{DD} = 10V$		0.05		0	0.05		0.05	V
		$V_{DD} = 15V$		0.05		0	0.05		0.05	V
V_{OH}	High Level Output Voltage	$ I_O < 1 \mu A$ $V_{DD} = 5V$	4.95		4.95	5		4.95		V
		$V_{DD} = 10V$	9.95		9.95	10		9.95		V
		$V_{DD} = 15V$	14.95		14.95	15		14.95		V
V_{IL}	Low Level Input Voltage	$V_{DD} = 5V, V_O = 0.5V$ or 4.5V		1.5		2.25	1.5		1.5	V
		$V_{DD} = 10V, V_O = 1V$ or 9V		3.0		4.5	3.0		3.0	V
		$V_{DD} = 15V, V_O = 1.5V$ or 13.5V		4.0		6.75	4.0		4.0	V

DC Electrical Characteristics CD4018BC (Note 2) (Continued)

Symbol	Parameter	Conditions	-40°C		+25°C			+85°C		Units
			Min	Max	Min	Typ	Max	Min	Max	
V _{IH}	High Level Input Voltage	V _{DD} = 5V, V _O = 0.5V or 4.5V	3.5		3.5	2.75		3.5		V
		V _{DD} = 10V, V _O = 1V or 9V	7.0		7.0	5.5		7.0		V
		V _{DD} = 15V, V _O = 1.5V or 13.5V	11.0		11.0	8.25		11.0		V
I _{OL}	Low Level Output Current (Note 3)	V _{DD} = 5V, V _O = 0.4V	0.52		0.44	0.88		0.36		mA
		V _{DD} = 10V, V _O = 0.5V	1.3		1.1	2.25		0.9		mA
		V _{DD} = 15V, V _O = 1.5V	3.6		3.0	8.8		2.4		mA
I _{OH}	High Level Output Current (Note 3)	V _{DD} = 5V, V _O = 4.6V	-0.52		-0.44	-0.88		-0.36		mA
		V _{DD} = 10V, V _O = 9.5V	-1.3		-1.1	-2.25		-0.9		mA
		V _{DD} = 15V, V _O = 13.5V	-3.6		-3.0	-8.8		-2.4		mA
I _{IN}	Input Current	V _{DD} = 15V, V _{IN} = 0V V _{DD} = 15V, V _{IN} = 15V		-0.3 0.3		-10 ⁻⁵ 10 ⁻⁵	-0.3 0.3		-1.0 1.0	μA μA

AC Electrical Characteristics*

T_A = 25°C, C_L = 50 pF, R_L = 200k, Input t_r = t_f = 20 ns, unless otherwise specified

Symbol	Parameter	Conditions	Min	Typ	Max	Units
CLOCK OPERATION						
t _{PHL} , t _{PLH}	Propagation Delay Time to \bar{Q}	V _{DD} = 5V V _{DD} = 10V V _{DD} = 15V		235 95 70	700 250 200	ns ns ns
t _{THL} , t _{TLH}	Transition Time \bar{Q} Outputs	V _{DD} = 5V V _{DD} = 10V V _{DD} = 15V		125 65 50	250 130 100	ns ns ns
t _{WL} , t _{WH}	Minimum Clock Pulse Width	V _{DD} = 5V V _{DD} = 10V V _{DD} = 15V		125 50 40	500 200 160	ns ns ns
t _{RCL} , t _{FCL}	Clock Rise and Fall Time	V _{DD} = 5V V _{DD} = 10V V _{DD} = 15V			15 15 15	μs μs μs
t _{SU}	Minimum Data Input Set-Up Time	V _{DD} = 5V V _{DD} = 10V V _{DD} = 15V		40 20 16	200 100 80	ns ns ns
f _{CL}	Maximum Clock Frequency	V _{DD} = 5V V _{DD} = 10V V _{DD} = 15V	1 3 5	4 9 14		MHz MHz MHz
PRESET OR RESET OPERATION						
t _{PLH(R)} t _{PHL(PR)} t _{PLH(PR)}	Propagation Delay Time to \bar{Q}	V _{DD} = 5V V _{DD} = 10V V _{DD} = 15V		235 95 70	750 250 200	ns ns ns
t _{WH(R)} t _{WH(PR)}	Minimum Preset or Reset Pulse Width	V _{DD} = 5V V _{DD} = 10V V _{DD} = 15V		100 40 30	400 160 120	ns ns ns
t _{REM}	Minimum Preset or Reset Removal Time	V _{DD} = 5V V _{DD} = 10V V _{DD} = 15V		100 40 30	400 160 120	ns ns ns
C _{IN}	Average Input Capacitance	Any Input		5	7.5	pF
C _{PD}	Power Dissipation Capacitance	(Note 4)		63		pF

*AC Parameters are guaranteed by DC correlated testing.

Note 1: "Absolute Maximum Ratings" are those values beyond which the safety of the device cannot be guaranteed, they are not meant to imply that the devices should be operated at these limits. The table of "Recommended Operating Conditions" and "Electrical Characteristics" provides conditions for actual device operation.

Note 2: V_{SS} = 0V unless otherwise specified.

Note 3: I_{OL} and I_{OH} are tested one output at a time.

Note 4: C_{PD} determines the no load AC power consumption of any CMOS device. For complete explanation, see "54C/74C Family Characteristics", application note AN-90.

Typical Performance Characteristics

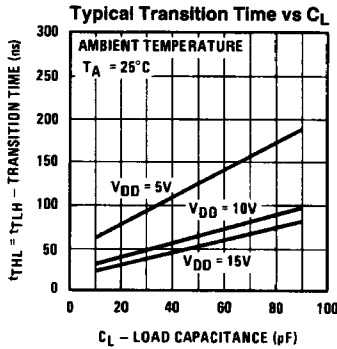

TL/F/5951-3

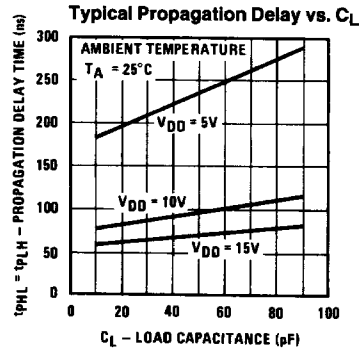

TL/F/5951-4

External Connections

External Connections for Divide by 10, 9, 8, 7, 6, 5, 4, 3, 2, Operation

Divide by 10 Q₅
Divide by 8 Q₄
Divide by 6 Q₃
Divide by 4 Q₂
Divide by 2 Q₁

} Connected Back
To "DATA" Input

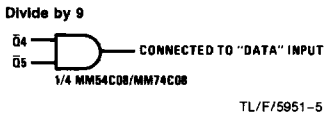

Timing Diagram

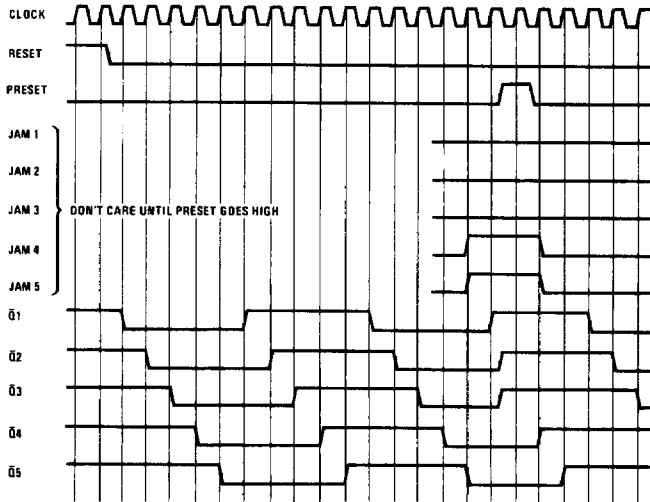

Note: "Data" input tied to Q₅ for decade counter configuration

TL/F/5951-9