

Automotive PSoC™ 4: PSoC™ 4100S Plus

Programmable system-on-chip

General description

PSoC™ 4 is a scalable and reconfigurable platform architecture for a family of programmable embedded system controllers with an Arm® Cortex®-M0+ CPU while being AEC-Q100 compliant. It combines programmable and reconfigurable analog and digital blocks with flexible automatic routing. PSoC™ 4100S Plus is a member of the PSoC™ 4 platform architecture. It is a combination of a microcontroller with standard communication and timing peripherals, a capacitive touch-sensing system (CAPSENSE™) with best-in-class performance, programmable general-purpose continuous-time and switched-capacitor analog blocks, and programmable connectivity. PSoC™ 4100S Plus products will be upward compatible with members of the PSoC™ 4 platform for new applications and design needs.

Features

- Automotive Electronics Council (AEC) AEC-Q100 Qualified
- 32-bit MCU subsystem
 - 48-MHz Arm® Cortex®-M0+ CPU
 - Up to 128 KB of flash with Read Accelerator
 - Up to 16 KB of SRAM
 - 8-channel DMA engine
- Programmable analog
 - Two opamps with reconfigurable high-drive external and high-bandwidth internal drive and comparator modes and ADC input buffering capability. Opamps can operate in Deep Sleep low-power mode.
 - 12-bit 1-Msps SAR ADC with differential and single-ended modes, and channel sequencer with signal averaging
 - Single-slope 10-bit ADC function provided by a capacitance sensing block
 - Two current DACs (IDACs) for general-purpose or capacitive sensing applications on any pin
 - Two low-power comparators that operate in Deep Sleep low-power mode
- Programmable digital
 - Programmable logic blocks allowing Boolean operations to be performed on port inputs and outputs
- Low-power 1.71 V to 5.5 V operation
 - Deep Sleep mode with operational analog and 2.5 µA digital system current
- Capacitive sensing
 - Capacitive sigma-delta (CSD) provides best-in-class signal-to-noise ratio (SNR) (> 5:1) and water tolerance
 - Infineon-supplied software component makes capacitive sensing design easy
 - Automatic hardware tuning (SmartSense)
- LCD drive capability
 - LCD segment drive capability on GPIOs
- Serial communication
 - Five independent run-time reconfigurable serial communication blocks (SCBs) with re-configurable I²C, SPI, UART functionality, or LIN slave functionality
- Timing and pulse-width modulation
 - Eight 16-bit timer/counter/pulse-width modulator (TCPWM) blocks
 - Center-aligned, Edge, and Pseudo-random modes
 - Comparator-based triggering of Kill signals for motor drive and other high-reliability digital logic applications
 - Quadrature decoder
- Clock sources
 - 4 to 33 MHz external crystal oscillator (ECO)

Features

- PLL to generate 48-MHz frequency
- 32-kHz watch crystal oscillator (WCO)
- $\pm 2\%$ internal main oscillator (IMO)
- 32-kHz internal low-power oscillator (ILO)
- True random number generator (TRNG)
 - TRNG generates truly random number for secure key generation for cryptography applications
- CAN block
 - CAN 2.0B block with support for time-triggered CAN (TTCAN)
- Temperature range
 - Grade-A: $-40\text{ }^{\circ}\text{C}$ to $+85\text{ }^{\circ}\text{C}$
 - Grade-S: $-40\text{ }^{\circ}\text{C}$ to $+105\text{ }^{\circ}\text{C}$
 - Grade-E: $-40\text{ }^{\circ}\text{C}$ to $+125\text{ }^{\circ}\text{C}$
- Up to 54 programmable GPIO pins
 - 40-pin QFN, 48-pin QFN, 64-pin QFN, and 64-pin TQFP packages
 - Any GPIO pin can be CAPSENSE™, analog, or digital
 - Drive modes, strengths, and slew rates are programmable
- PSoC Creator Design Environment
 - Integrated development environment (IDE) provides schematic design entry and build (with analog and digital automatic routing)
 - Applications programming interface (API) component for all fixed-function and programmable peripherals
- Industry-standard tool compatibility
 - After schematic entry, development can be done with Arm®-based industry-standard development tools

More information

1 More information

Infineon provides a wealth of data at www.infineon.com to help you to select the right PSoC device for your design, and to help you to quickly and effectively integrate the device into your design. For a comprehensive list of resources, see the knowledge base article [KBA86521, How to Design with PSoC 3, PSoC 4, and PSoC 5LP](#). Following is an abbreviated list for PSoC 4:

- Overview: [PSoC™ Portfolio](#), [PSoC™ Roadmap](#)
- Product selectors: [PSoC™ 1](#), [PSoC™ 3](#), [PSoC™ 4](#), [PSoC 5LP](#)
In addition, PSoC™ Creator includes a device selection tool.
- Application notes: Infineon offers a large number of PSoC™ application notes covering a broad range of topics, from basic to advanced level. Recommended application notes for getting started with PSoC™ 4 are:
 - [AN79953](#): Getting started With PSoC™ 4
 - [AN88619](#): PSoC™ 4 hardware design considerations
 - [AN86439](#): Using PSoC™ 4 GPIO pins
 - [AN57821](#): Mixed signal circuit board layout
 - [AN81623](#): Digital design best practices
 - [AN73854](#): Introduction to bootloaders
 - [AN89610](#): Arm® Cortex® code optimization
 - [AN85951](#): PSoC™ 4 and PSoC™ analog coprocessor CAPSENSE™ design guide
- Technical reference manual (TRM) is in two documents:
 - [Architecture TRM](#) details each PSoC™ 4 functional block.
 - [Registers TRM](#) describes each of the PSoC™ 4 registers.
- Development kits:
 - [CY8CKIT-041-41XX PSoC™ 4100S CAPSENSE™](#) pioneer kit, is an easy-to-use and inexpensive development platform. This kit includes connectors for Arduino™ compatible shields.
 - [CY8CKIT-149](#) PSoC™ 4100S Plus prototyping kit enables you to evaluate and develop with Infineon's fourth-generation, low-power CAPSENSE™ solution using the PSoC™ 4100S Plus devices.

The [MiniProg3](#) device provides an interface for flash programming and debug.

- **Software user guide:**
 - A step-by-step guide for using PSoC™ Creator. The software user guide shows you how the PSoC™ Creator build process works in detail, how to use source control with PSoC™ Creator, and much more.
- Component datasheets:
 - The flexibility of PSoC™ allows the creation of new peripherals (components) long after the device has gone into production. Component datasheets provide all the information needed to select and use a particular component, including a functional description, API documentation, example code, and AC/DC specifications.
- Online:
 - In addition to print documentation, the [Infineon community page](#) connects you with fellow PSoC™ users and experts in PSoC™ from around the world, 24 hours a day, 7 days a week.

2 PSoC™ Creator

PSoC™ Creator is a free Windows-based integrated design environment (IDE). It enables concurrent hardware and firmware design of PSoC™ 3, PSoC™ 4, and PSoC™ 5LP based systems. Create designs using classic, familiar schematic capture supported by over 100 pre-verified, production-ready PSoC™ Components; see the [list of component datasheets](#). With PSoC™ Creator, you can:

1. Drag and drop component icons to build your hardware system design in the main design workspace
2. Codesign your application firmware with the PSoC™ hardware, using the PSoC™ Creator IDE C compiler
3. Configure components using the configuration tools
4. Explore the library of 100+ components
5. Review component datasheets

Figure 1 Multiple-sensor example project in PSoC™ Creator

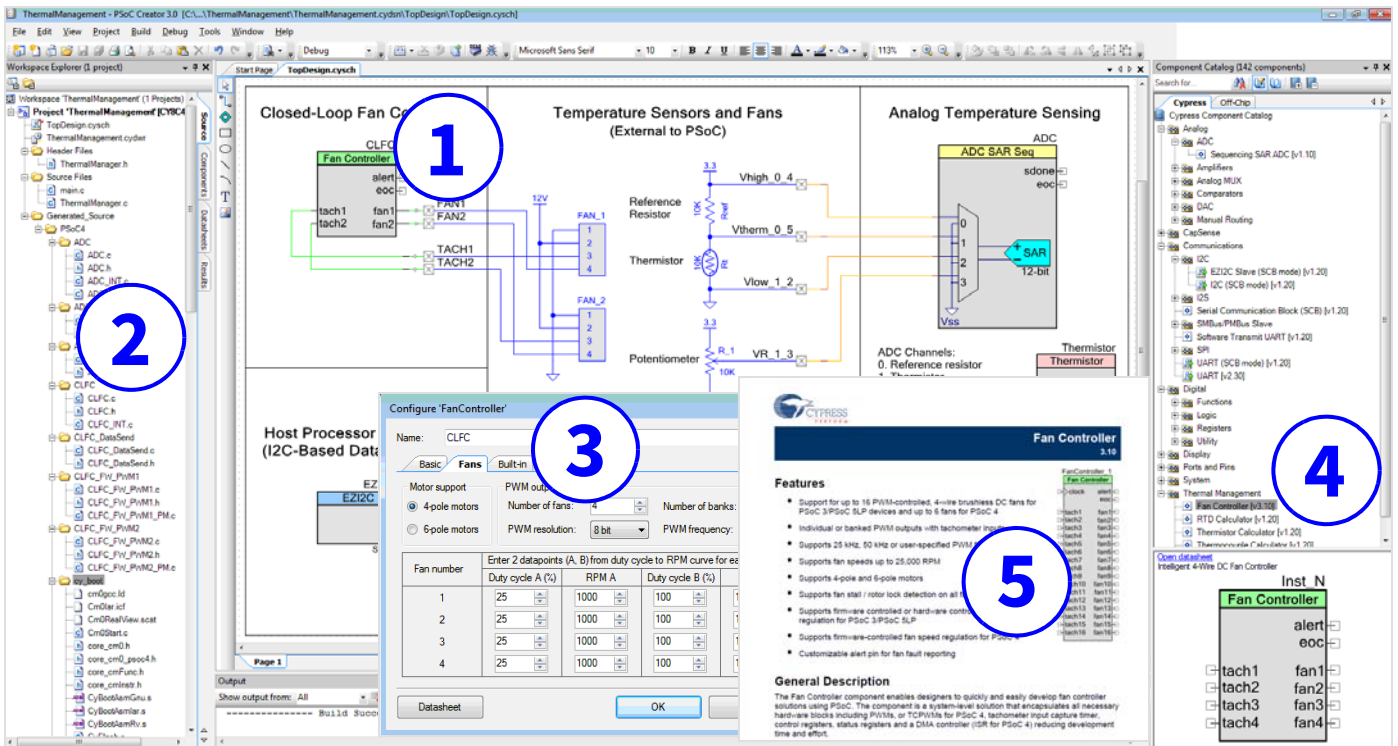

Table of contents

General description	1
Features	1
1 More information	3
2 PSoC™ Creator	4
Table of contents	5
3 Block diagram	6
4 Functional description	7
5 Functional definition	8
5.1 CPU and memory subsystem	8
5.2 System resources	8
5.3 Analog blocks	10
5.4 Programmable digital blocks	11
5.5 Fixed function digital blocks	12
5.6 GPIO	13
5.7 Special function peripherals	14
6 Pinouts	15
6.1 Alternate pin functions	17
7 Power	20
7.1 Mode 1: 1.8 V to 5.5 V external supply	20
7.2 Mode 2: 1.8 V ±5% external supply	20
8 Electrical specifications	22
8.1 Absolute maximum ratings	22
8.2 Device-level specifications	23
8.3 Analog peripherals	27
8.4 Digital peripherals.....	37
8.5 Memory	41
8.6 System resources	42
9 Ordering information	47
10 Packaging	61
10.1 Package diagrams.....	62
11 Acronyms	66
12 Document conventions	70
12.1 Units of measure	70
Revision history	71

Block diagram

3 Block diagram

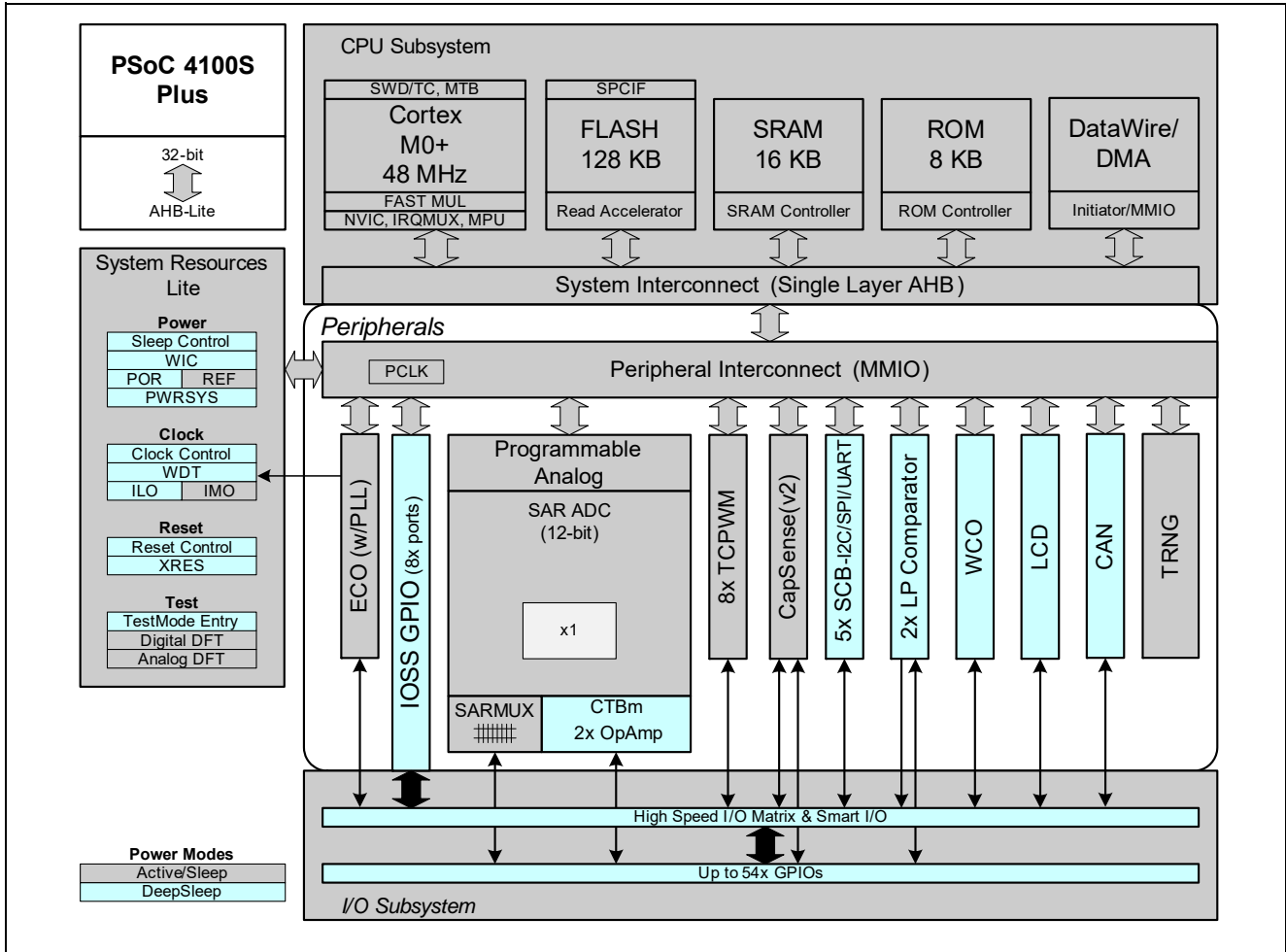

Figure 2 Block diagram

4 Functional description

PSoC™ 4100S Plus devices include extensive support for programming, testing, debugging, and tracing both hardware and firmware.

The Arm® serial-wire debug (SWD) interface supports all programming and debug features of the device.

Complete debug-on-chip functionality enables full-device debugging in the final system using the standard production device. It does not require special interfaces, debugging pods, simulators, or emulators. Only the standard programming connections are required to fully support debug.

The PSoC™ Creator IDE provides fully integrated programming and debug support for the PSoC™ 4100S Plus devices. The SWD interface is fully compatible with industry-standard third-party tools. PSoC™ 4100S Plus provides a level of security not possible with multi-chip application solutions or with microcontrollers. It has the following advantages:

- Allows disabling of debug features
- Robust flash protection
- Allows customer-proprietary functionality to be implemented in on-chip programmable blocks

The debug circuits are enabled by default and can be disabled in firmware. If they are not enabled, the only way to re-enable them is to erase the entire device, clear flash protection, and reprogram the device with new firmware that enables debugging. Thus firmware control of debugging cannot be over-ridden without erasing the firmware thus providing security.

Additionally, all device interfaces can be permanently disabled (device security) for applications concerned about phishing attacks due to a maliciously reprogrammed device or attempts to defeat security by starting and interrupting flash programming sequences. All programming, debug, and test interfaces are disabled when maximum device security is enabled. Therefore, PSoC™ 4100S Plus, with device security enabled, may not be returned for failure analysis. This is a trade-off the PSoC™ 4100S Plus allows the customer to make.

5 Functional definition

5.1 CPU and memory subsystem

5.1.1 CPU

The Cortex®-M0+ CPU in the PSoC™ 4100S Plus is part of the 32-bit MCU subsystem, which is optimized for low-power operation with extensive clock gating. Most instructions are 16 bits in length and the CPU executes a subset of the Thumb-2 instruction set. It includes a nested vectored interrupt controller (NVIC) block with eight interrupt inputs and also includes a Wakeup Interrupt Controller (WIC). The WIC can wake the processor from Deep Sleep mode, allowing power to be switched off to the main processor when the chip is in Deep Sleep mode. The CPU subsystem includes an 8-channel DMA engine and also includes a debug interface, the SWD interface, which is a 2-wire form of JTAG. The debug configuration used for PSoC™ 4100S Plus has four breakpoint (address) comparators and two watchpoint (data) comparators.

5.1.2 Flash

The PSoC™ 4100S Plus device has a flash module with a flash accelerator, tightly coupled to the CPU to improve average access times from the flash block. The low-power flash block is designed to deliver two wait-state (WS) access time at 48 MHz. The flash accelerator delivers 85% of single-cycle SRAM access performance on average.

5.1.3 SRAM

16 KB of SRAM are provided with zero wait-state access at 48 MHz.

5.1.4 SRAM

An 8-KB supervisory ROM that contains boot and configuration routines is provided.

5.2 System resources

5.2.1 Power system

The power system is described in detail in the section [Power](#). It provides assurance that voltage levels are as required for each respective mode and either delays mode entry (for example, on power-on reset (POR)) until voltage levels are as required for proper functionality, or generates resets (for example, on brownout detection). PSoC™ 4100S Plus operates with a single external supply over the range of either 1.8 V \pm 5% (externally regulated) or 1.8 V to 5.5 V (internally regulated) and has three different power modes, transitions between which are managed by the power system. PSoC™ 4100S Plus provides Active, Sleep, and Deep Sleep low-power modes.

All subsystems are operational in Active mode. The CPU subsystem (CPU, flash, and SRAM) is clock-gated off in Sleep mode, while all peripherals and interrupts are active with instantaneous wake-up on a wake-up event. In Deep Sleep mode, the high-speed clock and associated circuitry is switched off; wake-up from this mode takes 35 μ s. The opamps can remain operational in Deep Sleep mode.

5.2.2 Clock system

The PSoC™ 4100S Plus clock system is responsible for providing clocks to all subsystems that require clocks and for switching between different clock sources without glitching. In addition, the clock system ensures that there are no metastable conditions.

The clock system for the PSoC™ 4100S Plus consists of the IMO, ILO, a 32-kHz watch crystal oscillator (WCO), MHz ECO and PLL, and provision for an external clock. The WCO block allows locking the IMO to the 32-kHz oscillator.

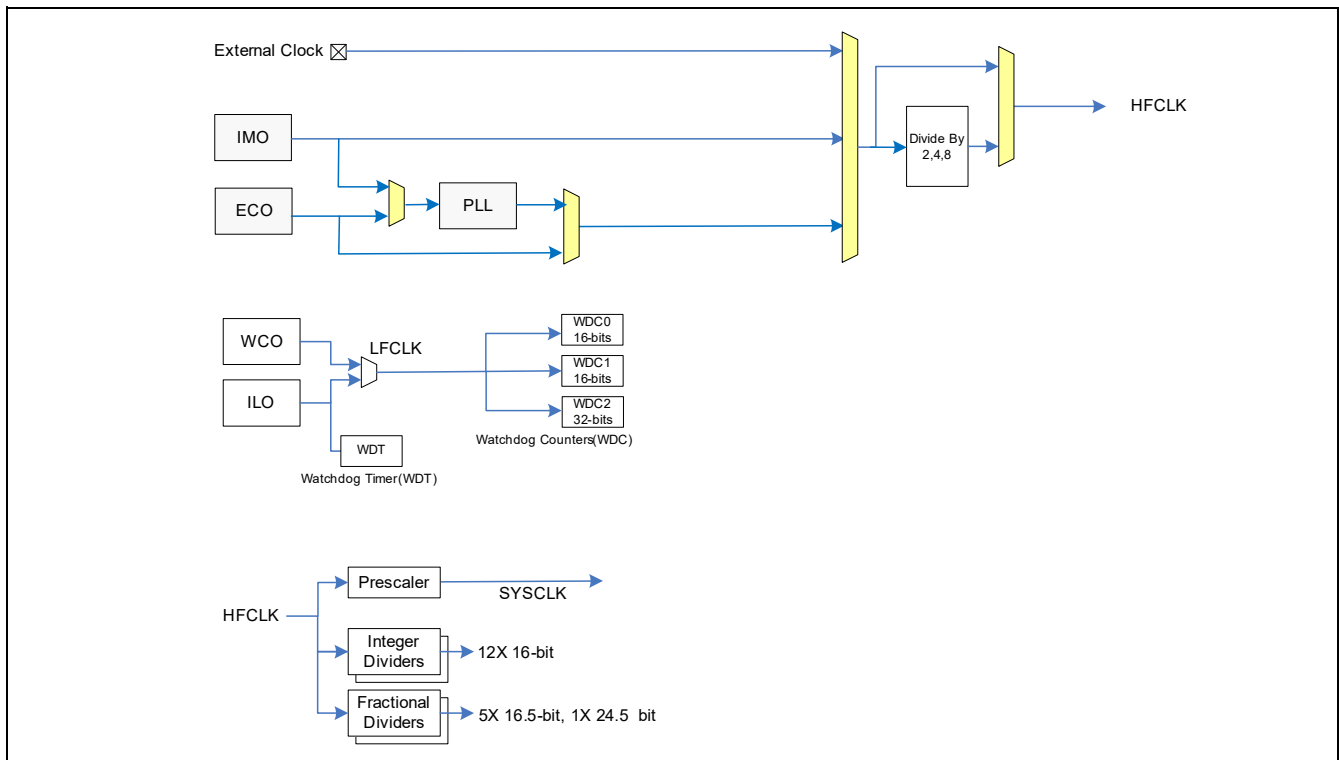

Figure 3 PSoC™ 4100S Plus MCU clocking architecture

The HFCLK signal can be divided down as shown to generate synchronous clocks for the Analog and Digital peripherals. There are 18 clock dividers for the PSoC 4100S Plus (six with fractional divide capability, twelve with integer divide only). The twelve 16-bit integer divide capability allows a lot of flexibility in generating fine-grained frequency. In addition, there are five 16-bit fractional dividers and one 24-bit fractional divider.

5.2.3 IMO clock source

The IMO is the primary source of internal clocking in the PSoC 4100S Plus. It is trimmed during testing to achieve the specified accuracy. The IMO default frequency is 24 MHz and it can be adjusted from 24 to 48 MHz in steps of 4 MHz. The IMO tolerance with Cypress-provided calibration settings is $\pm 2\%$ over the entire voltage and temperature range.

5.2.4 ILO clock source

The ILO is a very low power, nominally 40-kHz oscillator, which is primarily used to generate clocks for the watchdog timer (WDT) and peripheral operation in Deep Sleep mode. ILO-driven counters can be calibrated to the IMO to improve accuracy. Cypress provides a software component, which does the calibration.

5.2.5 WCO

The PSoC™ 4100S Plus clock subsystem also implements a low-frequency (32-kHz watch crystal) oscillator that can be used for precision timing applications.

5.2.6 ECO

The PSoC™ 4100S Plus also implements a 4 to 33 MHz crystal oscillator.

5.2.7 WDT

A watchdog timer is implemented in the clock block running from the ILO; this allows watchdog operation during Deep Sleep and generates a watchdog reset if not serviced before the set timeout occurs. The watchdog reset is recorded in a Reset Cause register, which is firmware readable.

5.2.8 Reset

PSoC™ 4100S Plus can be reset from a variety of sources including a software reset. Reset events are asynchronous and guarantee reversion to a known state. The reset cause is recorded in a register, which is sticky through reset and allows software to determine the cause of the reset. An XRES pin is reserved for external reset by asserting it active low. The XRES pin has an internal pull-up resistor that is always enabled.

5.3 Analog blocks

5.3.1 12-bit SAR ADC

The 12-bit, 1-Msps SAR ADC can operate at a maximum clock rate of 18 MHz and requires a minimum of 18 clocks at that frequency to do a 12-bit conversion.

The sample-and-hold (S/H) aperture is programmable allowing the gain bandwidth requirements of the amplifier driving the SAR inputs, which determine its settling time, to be relaxed if required. It is possible to provide an external bypass (through a fixed pin location) for the internal reference amplifier.

The SAR is connected to a fixed set of pins through an 8-input sequencer. The sequencer cycles through selected channels autonomously (sequencer scan) with zero switching overhead (that is, aggregate sampling bandwidth is equal to 1 Msps whether it is for a single channel or distributed over several channels). The sequencer switching is effected through a state machine or through firmware driven switching. A feature provided by the sequencer is buffering of each channel to reduce CPU interrupt service requirements. To accommodate signals with varying source impedance and frequency, it is possible to have different sample times programmable for each channel. Also, signal range specification through a pair of range registers (low and high range values) is implemented with a corresponding out-of-range interrupt if the digitized value exceeds the programmed range; this allows fast detection of out-of-range values without the necessity of having to wait for a sequencer scan to be completed and the CPU to read the values and check for out-of-range values in software.

The SAR is not available in Deep Sleep mode as it requires a high-speed clock (up to 18 MHz). The SAR operating range is 1.71 V to 5.5 V.

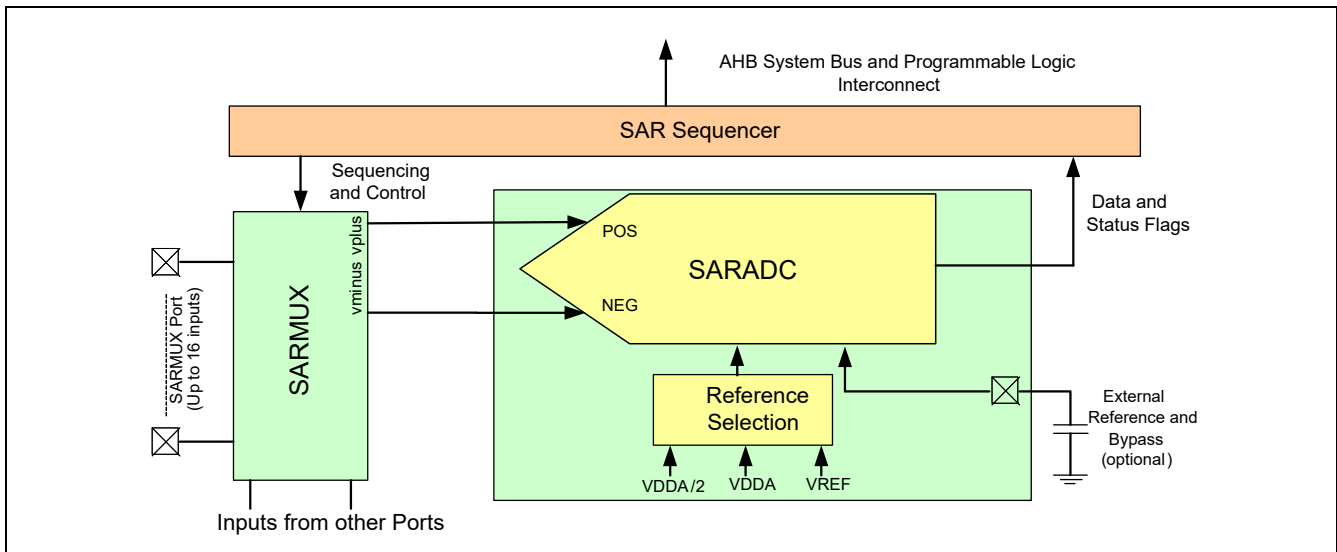

Figure 4 SAR ADC

5.3.2 Two opamps (continuous-time block; CTB)

PSoC™ 4100S Plus has two opamps with Comparator modes which allow most common analog functions to be performed on-chip eliminating external components; PGAs, voltage buffers, filters, trans-impedance amplifiers, and other functions can be realized, in some cases with external passives. saving power, cost, and space. The on-chip opamps are designed with enough bandwidth to drive the sample-and-hold circuit of the ADC without requiring external buffering.

5.3.3 Low-power comparators (LPC)

PSoC™ 4100S Plus has a pair of low-power comparators, which can also operate in Deep Sleep modes. This allows the analog system blocks to be disabled while retaining the ability to monitor external voltage levels during low-power modes. The comparator outputs are normally synchronized to avoid metastability unless operating in an asynchronous power mode where the system wake-up circuit is activated by a comparator switch event. The LPC outputs can be routed to pins.

5.3.4 Current DACs

PSoC™ 4100S Plus has two IDACs, which can drive any of the pins on the chip. These IDACs have programmable current ranges.

5.3.5 Analog multiplexed buses

PSoC™ 4100S Plus has two concentric independent buses that go around the periphery of the chip. These buses (called amux buses) are connected to firmware-programmable analog switches that allow the chip's internal resources (IDACs, comparator) to connect to any pin on the I/O ports.

5.4 Programmable digital blocks

5.4.1 Smart I/O block

The Smart I/O block is a fabric of switches and LUTs that allows Boolean functions to be performed in signals being routed to the pins of a GPIO port. The Smart I/O can perform logical operations on input pins to the chip and on signals going out as outputs.

5.5 Fixed function digital blocks

5.5.1 Timer/counter/PWM (TCPWM) block

The TCPWM block consists of a 16-bit counter with user-programmable period length. There is a capture register to record the count value at the time of an event (which may be an I/O event), a period register that is used to either stop or auto-reload the counter when its count is equal to the period register, and compare registers to generate compare value signals that are used as PWM duty cycle outputs. The block also provides true and complementary outputs with programmable offset between them to allow use as dead-band programmable complementary PWM outputs. It also has a Kill input to force outputs to a predetermined state; for example, this is used in motor drive systems when an over-current state is indicated and the PWM driving the FETs needs to be shut off immediately with no time for software intervention. Each block also incorporates a quadrature decoder. There are eight TCPWM blocks in PSoC™ 4100S Plus.

5.5.2 Serial communication block (SCB)

PSoC™ 4100S Plus has five serial communication blocks, which can be programmed to have SPI, I²C, UART, or LIN Slave functionality.

I²C Mode: The hardware I²C block implements a full multi-master and slave interface (it is capable of multi-master arbitration). This block is capable of operating at speeds of up to 1 Mbps (Fast Mode Plus) and has flexible buffering options to reduce interrupt overhead and latency for the CPU. It also supports EZI²C that creates a mailbox address range in the memory of PSoC™ 4100S Plus and effectively reduces I²C communication to reading from and writing to an array in memory. In addition, the block supports an 8-deep FIFO for receive and transmit which, by increasing the time given for the CPU to read data, greatly reduces the need for clock stretching caused by the CPU not having read data on time.

The I²C peripheral is compatible with the I²C Standard-mode and Fast-mode Plus devices as defined in the NXP I²C-bus specification and user manual (UM10204). The I²C bus I/O is implemented with GPIO in open-drain modes.

PSoC™ 4100S Plus is not completely compliant with the I²C spec in the following respect:

- GPIO cells are not over-voltage tolerant and, therefore, cannot be hot-swapped or powered up independently of the rest of the I²C system.

UART Mode: This is a full-feature UART operating at up to 1 Mbps. It supports automotive single-wire interface (LIN), infrared interface (IrDA), and SmartCard (ISO7816) protocols, all of which are minor variants of the basic UART protocol. In addition, it supports the 9-bit multiprocessor mode that allows addressing of peripherals connected over common RX and TX lines. Common UART functions such as parity error, break detect, and frame error are supported. An 8-deep FIFO allows much greater CPU service latencies to be tolerated.

SPI Mode: The SPI mode supports full Motorola SPI, TI SSP (adds a start pulse used to synchronize SPI Codecs), and National Microwire (half-duplex form of SPI). The SPI block can use the FIFO.

LIN Slave Mode: The LIN slave mode uses the SCB hardware block and implements a full LIN slave interface. This LIN slave is compliant with LIN v1.3, v2.1/2.2, ISO 17987-6, and SAE J2602-2 specification standards. It is certified by C&S GmbH based on the standard protocol and data link layer conformance tests. LIN slave can be operated at baud rates of up to ~20 Kbps with a maximum of 40-meter cable length. The PSoC™ Creator software supports up to two LIN slave interfaces in the PSoC™ 4 device, providing built-in application programming interfaces (APIs) based on the LIN specification standard.

5.5.3 CAN

There is one CAN block, which implements CAN 2.0B as defined in the Bosch specifications and conform to the ISO-11898-1 standard.

5.6 GPIO

PSoC™ 4100S Plus has up to 54 GPIOs. The GPIO block implements the following:

- Eight drive modes:
 - Analog input mode (input and output buffers disabled)
 - Input only
 - Weak pull-up with strong pull-down
 - Strong pull-up with weak pull-down
 - Open drain with strong pull-down
 - Open drain with strong pull-up
 - Strong pull-up with strong pull-down
 - Weak pull-up with weak pull-down
- Input threshold select (CMOS or LVTTTL).
- Individual control of input and output buffer enabling/disabling in addition to the drive strength modes
- Selectable slew rates for dV/dt related noise control to improve EMI

The pins are organized in logical entities called ports, which are 8-bit in width (less for Ports 5 and 6). During power-on and reset, the blocks are forced to the disabled state so as not to crowbar any inputs and/or cause excess turn-on current. A multiplexing network known as a high-speed I/O matrix is used to multiplex between various signals that may connect to an I/O pin.

Data output and pin state registers store, respectively, the values to be driven on the pins and the states of the pins themselves.

Every I/O pin can generate an interrupt if so enabled and each I/O port has an interrupt request (IRQ) and interrupt service routine (ISR) vector associated with it.

5.7 Special function peripherals

5.7.1 CAPSENSE™

CAPSENSE™ is supported in the PSoC™ 4100S Plus through a CAPSENSE™ sigma-delta (CSD) block that can be connected to any pins through an analog multiplex bus via analog switches. CAPSENSE™ function can thus be provided on any available pin or group of pins in a system under software control. A PSoC™ Creator component is provided for the CAPSENSE™ block to make it easy for the user.

Shield voltage can be driven on another analog multiplex bus to provide water-tolerance capability. Water tolerance is provided by driving the shield electrode in phase with the sense electrode to keep the shield capacitance from attenuating the sensed input. Proximity sensing can also be implemented.

The CAPSENSE™ block has two IDACs, which can be used for general purposes if CAPSENSE™ is not being used (both IDACs are available in that case) or if CAPSENSE™ is used without water tolerance (one IDAC is available).

The CAPSENSE™ block also provides a 10-bit Slope ADC function which can be used in conjunction with the CAPSENSE™ function.

The CAPSENSE™ block is an advanced, low-noise, programmable block with programmable voltage references and current source ranges for improved sensitivity and flexibility. It can also use an external reference voltage. It has a full-wave CSD mode that alternates sensing to VDDA and ground to null out power-supply related noise.

5.7.2 LCD segment drive

PSoC™ 4100S Plus has an LCD controller, which can drive up to 4 commons and up to 50 segments. It uses full digital methods to drive the LCD segments requiring no generation of internal LCD voltages. The two methods used are referred to as Digital Correlation and PWM. Digital Correlation pertains to modulating the frequency and drive levels of the common and segment signals to generate the highest RMS voltage across a segment to light it up or to keep the RMS signal to zero. This method is good for STN displays but may result in reduced contrast with TN (cheaper) displays. PWM pertains to driving the panel with PWM signals to effectively use the capacitance of the panel to provide the integration of the modulated pulse-width to generate the desired LCD voltage. This method results in higher power consumption but can result in better results when driving TN displays. LCD operation is supported during Deep Sleep refreshing a small display buffer (4 bits; one 32-bit register per port).

6 Pinouts

Table 1 Pin list for 40-pin QFN, 48-pin QFN, 64-pin QFN and 64-pin TQFP packages

40-pin QFN		64-pin TQFP, 64-pin QFN		64-pin TQFP, 64-pin QFN		48-pin QFN	
Pin	Name	Pin	Name	Pin	Name	Pin	Name
22	P0.0	39	P0.0	8	P2.6	28	P0.0
23	P0.1	40	P0.1	9	P2.7	29	P0.1
24	P0.2	41	P0.2	10	VSSD	30	P0.2
25	P0.3	42	P0.3	11	No Connect (NC)	31	P0.3
26	P0.4	43	P0.4	12	P6.0	32	P0.4
27	P0.5	44	P0.5	13	P6.1	33	P0.5
28	P0.6	45	P0.6	14	P6.2	34	P0.6
29	P0.7	46	P0.7	15	P6.4	35	P0.7
30	XRES	47	XRES	16	P6.5	36	XRES
31	VCCD	48	VCCD	17	VSSD	37	VCCD
32	VSSD	49	VSSD	18	P3.0	38	VCCD
33	VDD	50	VDDD	19	P3.1	39	VDDD
34	VSSA	51	P5.0	20	P3.2	40	VDDA
35	P1.0	52	P5.1	21	P3.3	41	VSSA
36	P1.1	53	P5.2	22	P3.4	42	P1.0
37	P1.2	54	P5.3	23	P3.5	43	P1.1
38	P1.3	55	P5.5	24	P3.6	44	P1.2
39	P1.4	56	VDDA	25	P3.7	45	P1.3
40	P1.7/VREF	57	VSSA	26	VDDD	46	P1.4
1	P2.3	58	P1.0	27	P4.0	47	P1.5
2	P2.4	59	P1.1	28	P4.1	48	P1.6
3	P2.5	60	P1.2	29	P4.2	1	P1.7
4	P2.6	61	P1.3	30	P4.3	2	P2.0
5	P2.7	62	P1.4	31	P4.4	3	P2.1
6	P6.0	63	P1.5	32	P4.5	4	P2.2
7	P6.1	64	P1.6	33	P4.6	5	P2.3
8	P6.2	1	P1.7	34	P4.7	6	P2.4
9	VSSD	2	P2.0	35	P5.6	7	P2.5
10	P3.0	3	P2.1	36	P5.7	8	P2.6
11	P3.1	4	P2.2	37	P7.0	9	P2.7
12	P3.2	5	P2.3	38	P7.1	10	P6.1
13	P3.3	6	P2.4			11	P6.2
14	P3.4	7	P2.5			12	VSSD
15	P3.5					13	P3.0
16	P3.6					14	P3.1
17	P3.7					15	P3.2
18	P4.0					16	P3.3

Table 1 Pin list for 40-pin QFN, 48-pin QFN, 64-pin QFN and 64-pin TQFP packages (continued)

40-pin QFN		64-pin TQFP, 64-pin QFN		64-pin TQFP, 64-pin QFN		48-pin QFN	
Pin	Name	Pin	Name	Pin	Name	Pin	Name
19	P4.1					17	P3.4
20	P4.2					18	P3.5
21	P4.3					19	P3.6
						20	P3.7
						21	VDDD
						22	P4.0
						23	P4.1
						24	P4.2
						25	P4.3

Descriptions of the Power pins are as follows:

VDDD: Power supply for the digital section.

VDDA: Power supply for the analog section.

VSSD, VSSA: Ground pins for the digital and analog sections respectively.

VCCD: Regulated digital supply (1.8 V ±5%)

VDD: On some packages, VDDA and VDDD are shorted inside and brought out as a single power supply

GPIOs: 54

6.1 Alternate pin functions

Each port pin has can be assigned to one of multiple functions; it can, for example, be an analog I/O, a digital peripheral function, an LCD pin, or a CAPSENSE™ pin. The pin assignments are shown in the following table.

Table 2 Pin assignments

Port/Pin	Analog	Smart I/O	ACT #0	ACT #1	ACT #3	DS #2	DS #3
P0.0	lpcomp.in_p[0]			tcpwm.tr_in[0]	scb[2].uart_cts:0	scb[2].i2c_scl:0	scb[0].spi_select1:0
P0.1	lpcomp.in_n[0]			tcpwm.tr_in[1]	scb[2].uart_rts:0	scb[2].i2c_sda:0	scb[0].spi_select2:0
P0.2	lpcomp.in_p[1]						scb[0].spi_select3:0
P0.3	lpcomp.in_n[1]						scb[2].spi_select0:1
P0.4	wco.wco_in			scb[1].uart_rx:0	scb[2].uart_rx:0	scb[1].i2c_scl:0	scb[1].spi_mosi:1
P0.5	wco.wco_out			scb[1].uart_tx:0	scb[2].uart_tx:0	scb[1].i2c_sda:0	scb[1].spi_miso:1
P0.6	exco.eco_in		srss.ext_clk:0	scb[1].uart_cts:0	scb[2].uart_tx:1		scb[1].spi_clk:1
P0.7	exco.eco_out		tcpwm.line[0]:3	scb[1].uart_rts:0			scb[1].spi_select0:1
P5.0			tcpwm.line[4]:2		scb[2].uart_rx:1	scb[2].i2c_scl:1	scb[2].spi_mosi:0
P5.1			tcpwm.line_- compl[4]:2		scb[2].uart_tx:2	scb[2].i2c_sda:1	scb[2].spi_miso:0
P5.2			tcpwm.line[5]:2		scb[2].uart_cts:1	lpcomp.comp[0]:2	scb[2].spi_clk:0
P5.3			tcpwm.line_- compl[5]:2		scb[2].uart_rts:1	lpcomp.comp[1]:0	scb[2].spi_select0:0
P5.4			tcpwm.line[6]:2				scb[2].spi_select1:0
P5.5			tcpwm.line_- compl[6]:2				scb[2].spi_select2:0
P1.0	ctb0_oa0+	SmartIo[2].io[0]	tcpwm.line[2]:1	scb[0].uart_rx:1		scb[0].i2c_scl:0	scb[0].spi_mosi:1
P1.1	ctb0_oa0-	SmartIo[2].io[1]	tcpwm.line_- compl[2]:1	scb[0].uart_tx:1		scb[0].i2c_sda:0	scb[0].spi_miso:1
P1.2	ctb0_oa0_out	SmartIo[2].io[2]	tcpwm.line[3]:1	scb[0].uart_cts:1	tcpwm.tr_in[2]	scb[2].i2c_scl:2	scb[0].spi_clk:1
P1.3	ctb0_oa1_out	SmartIo[2].io[3]	tcpwm.line_- compl[3]:1	scb[0].uart_rts:1	tcpwm.tr_in[3]	scb[2].i2c_sda:2	scb[0].spi_select0:1
P1.4	ctb0_oa1-	SmartIo[2].io[4]	tcpwm.line[6]:1			scb[3].i2c_scl:0	scb[0].spi_select1:1



Table 2 Pin assignments (continued)

Port/Pin	Analog	Smart I/O	ACT #0	ACT #1	ACT #3	DS #2	DS #3
P1.5	ctb0_oa1+	SmartIo[2].io[5]]	tcpwm.line_ compl[6]:1			scb[3].i2c_sda:0	scb[0].spi_select2:1
P1.6	ctb0_oa0+	SmartIo[2].io[6]]	tcpwm.line[7]:1				scb[0].spi_select3:1
P1.7	ctb0_oa1+ sar_ext_vref0 sar_ext_vref1	SmartIo[2].io[7]]	tcpwm.line_ compl[7]:1				scb[2].spi_clk:1
P2.0	sarmux[0]	SmartIo[0].io[0]]	tcpwm.line[4]:0	csd.comp	tcpwm.tr_in[4]	scb[1].i2c_scl:1	scb[1].spi_mosi:2
P2.1	sarmux[1]	SmartIo[0].io[1]]	tcpwm.line_ compl[4]:0		tcpwm.tr_in[5]	scb[1].i2c_sda:1	scb[1].spi_miso:2
P2.2	sarmux[2]	SmartIo[0].io[2]]	tcpwm.line[5]:1				scb[1].spi_clk:2
P2.3	sarmux[3]	SmartIo[0].io[3]]	tcpwm.line_ compl[5]:1				scb[1].spi_select0:2
P2.4	sarmux[4]	SmartIo[0].io[4]]	tcpwm.line[0]:1	scb[3].uart_rx:1			scb[1].spi_select1:1
P2.5	sarmux[5]	SmartIo[0].io[5]]	tcpwm.line_ compl[0]:1	scb[3].uart_tx:1			scb[1].spi_select2:1
P2.6	sarmux[6]	SmartIo[0].io[6]]	tcpwm.line[1]:1	scb[3].uart_cts:1			scb[1].spi_select3:1
P2.7	sarmux[7]	SmartIo[0].io[7]]	tcpwm.line_ compl[1]:1	scb[3].uart_rts:1		lpcomp.comp[0]:0	scb[2].spi_mosi:1
P6.0			tcpwm.line[4]:1	scb[3].uart_rx:0	can.can_tx_ _enb_n:0	scb[3].i2c_scl:1	scb[3].spi_mosi:0
P6.1			tcpwm.line_ compl[4]:1	scb[3].uart_tx:0	can.can_rx:0	scb[3].i2c_sda:1	scb[3].spi_miso:0
P6.2			tcpwm.line[5]:0	scb[3].uart_cts:0	can.can_tx:0		scb[3].spi_clk:0
P6.4			tcpwm.line[6]:0			scb[4].i2c_scl	scb[3].spi_select1:0
P6.5			tcpwm.line_ compl[6]:0			scb[4].i2c_sda	scb[3].spi_select2:0
P3.0		SmartIo[1].io[0]]	tcpwm.line[0]:0	scb[1].uart_rx:1		scb[1].i2c_scl:2	scb[1].spi_mosi:0



Table 2 Pin assignments (continued)

Port/Pin	Analog	Smart I/O	ACT #0	ACT #1	ACT #3	DS #2	DS #3
P3.1		SmartIo[1].io[1]]	tcpwm.line_ compl[0]:0	scb[1].uart_tx:1		scb[1].i2c_sda:2	scb[1].spi_miso:0
P3.2		SmartIo[1].io[2]]	tcpwm.line[1]:0	scb[1].uart_cts:1		cpuss.swd_data	scb[1].spi_clk:0
P3.3		SmartIo[1].io[3]]	tcpwm.line_ compl[1]:0	scb[1].uart_rts:1		cpuss.swd_clk	scb[1].spi_select0:0
P3.4		SmartIo[1].io[4]]	tcpwm.line[2]:0		tcpwm.tr_in[6]		scb[1].spi_select1:0
P3.5		SmartIo[1].io[5]]	tcpwm.line_ compl[2]:0				scb[1].spi_select2:0
P3.6		SmartIo[1].io[6]]	tcpwm.line[3]:0			scb[4].spi_select3	scb[1].spi_select3:0
P3.7		SmartIo[1].io[7]]	tcpwm.line_ compl[3]:0			lpcomp.comp[1]:1	scb[2].spi_miso:1
P4.0	csd.vref_ext			scb[0].uart_rx:0	can.can_rx:1	scb[0].i2c_scl:1	scb[0].spi_mosi:0
P4.1	csd.cshield			scb[0].uart_tx:0	can.can_tx:1	scb[0].i2c_sda:1	scb[0].spi_miso:0
P4.2	csd.cmod			scb[0].uart_cts:0	can.can_tx_ _enb_n:1	lpcomp.comp[0]:1	scb[0].spi_clk:0
P4.3	csd.csh_tank			scb[0].uart_rts:0		lpcomp.comp[1]:2	scb[0].spi_select0:0
P4.4				scb[4].uart_rx		scb[4].spi_mosi	scb[0].spi_select1:2
P4.5				scb[4].uart_tx		scb[4].spi_miso	scb[0].spi_select2:2
P4.6				scb[4].uart_cts		scb[4].spi_clk	scb[0].spi_select3:2
P4.7				scb[4].uart_rts		scb[4].spi_select0	
P5.6			tcpwm.line[7]:0			scb[4].spi_select1	scb[2].spi_select3:0
P5.7			tcpwm.line_ compl[7]:0			scb[4].spi_select2	
P7.0			tcpwm.line[0]:2	scb[3].uart_rx:2		scb[3].i2c_scl:2	scb[3].spi_mosi:1
P7.1			tcpwm.line_ compl[0]:2	scb[3].uart_tx:2		scb[3].i2c_sda:2	scb[3].spi_miso:1
P7.2			tcpwm.line[1]:2	scb[3].uart_cts:2			scb[3].spi_clk:1

7 Power

The following power system diagram shows the set of power supply pins as implemented for the PSoC™ 4100S Plus. The system has one regulator in Active mode for the digital circuitry. There is no analog regulator; the analog circuits run directly from the VDDA input.

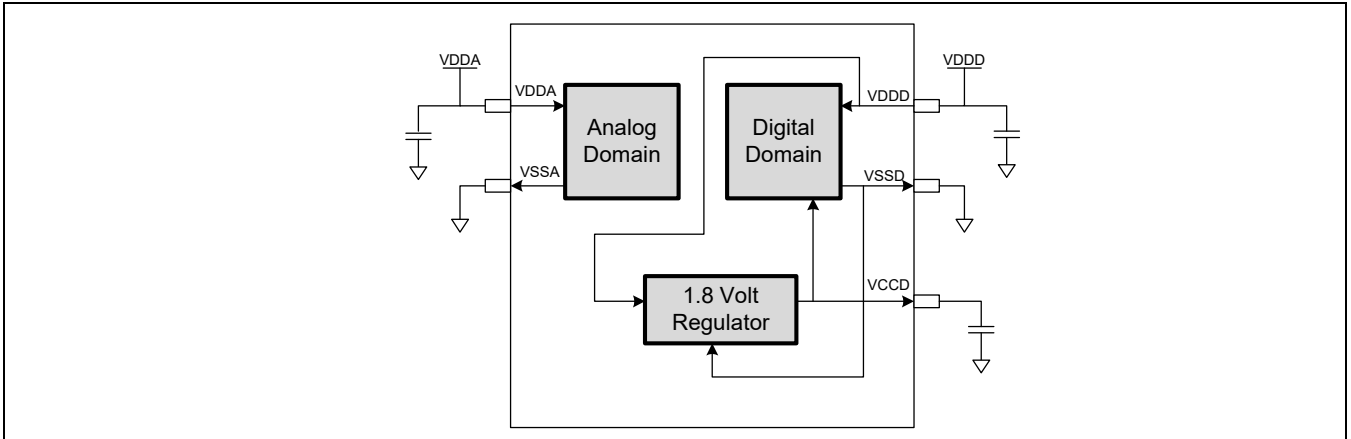

Figure 5 Power supply connections

There are two distinct modes of operation. In Mode 1, the supply voltage range is 1.8 V to 5.5 V (unregulated externally; internal regulator operational). In Mode 2, the supply range is 1.8 V \pm 5% (externally regulated; 1.71 to 1.89, internal regulator bypassed).

7.1 Mode 1: 1.8 V to 5.5 V external supply

In this mode, PSoC™ 4100S Plus is powered by an external power supply that can be anywhere in the range of 1.8 to 5.5 V. This range is also designed for battery-powered operation. For example, the chip can be powered from a battery system that starts at 3.5 V and works down to 1.8 V. In this mode, the internal regulator of PSoC™ 4100S Plus supplies the internal logic and its output is connected to the VCCD pin. The VCCD pin must be bypassed to ground via an external capacitor (0.1 μ F; X5R ceramic or better) and must not be connected to anything else.

7.2 Mode 2: 1.8 V \pm 5% external supply

In this mode, PSoC™ 4100S Plus is powered by an external power supply that must be within the range of 1.71 to 1.89 V; note that this range needs to include the power supply ripple too. In this mode, the VDD and VCCD pins are shorted together and bypassed.

Bypass capacitors must be used from VDDD to ground. The typical practice for systems in this frequency range is to use a capacitor in the 1- μ F range, in parallel with a smaller capacitor (0.1 μ F, for example). Note that these are simply rules of thumb and that, for critical applications, the PCB layout, lead inductance, and the bypass capacitor parasitic should be simulated to design and obtain optimal bypassing. On some packages, VDDD and VDDA pins are shorted inside the package and brought out as a generic VDD pin. In that case, only 0.1- μ F and 1- μ F decoupling capacitors are required on the VDD pin.

An example of a bypass scheme is shown in the following diagram.

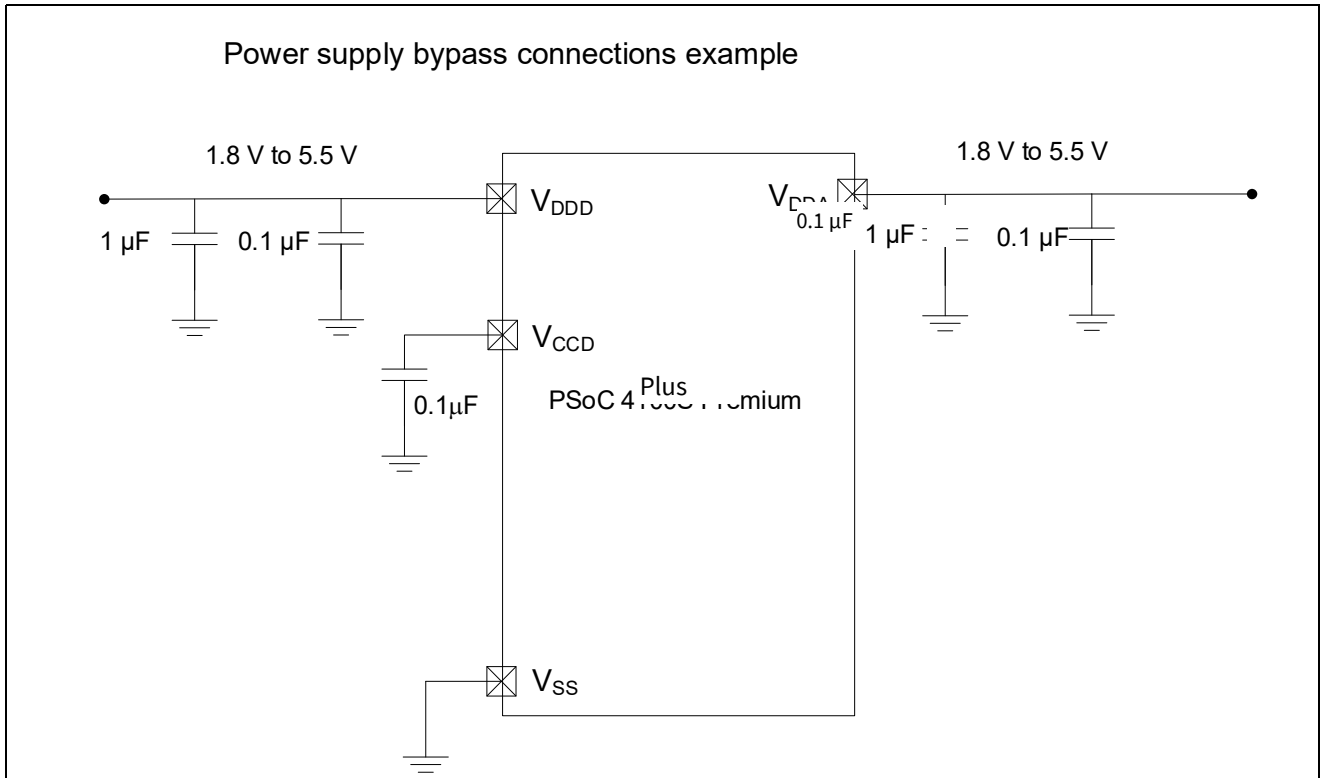

Figure 6 External supply range from 1.8 V to 5.5 V with internal regulator active

8 Electrical specifications

8.1 Absolute maximum ratings

Table 3 Absolute maximum ratings^[1]

Spec ID#	Parameter	Description	Min	Typ	Max	Unit	Details/ Conditions
SID1	V _{DDD_ABS}	Digital supply relative to V _{SS}	-0.5	-	6	V	-
SID2	V _{CCD_ABS}	Direct digital core voltage input relative to V _{SS}	-0.5	-	1.95		-
SID3	V _{GPIO_ABS}	GPIO voltage	-0.5	-	V _{DD} + 0.5		-
SID4	I _{GPIO_ABS}	Maximum current per GPIO	-25	-	25	mA	-
SID5	I _{GPIO_in-j} jection	GPIO injection current, Max for V _{IH} > V _{DDD} , and Min for V _{IL} < V _{SS}	-0.5	-	0.5		Current injected per pin
BID44	ESD_HBM	Electrostatic discharge human body model	2200	-	-	V	-
BID45	ESD_CDM	Electrostatic discharge charged device model	500	-	-		-
BID46	LU	Pin current for latch-up	-140	-	140	mA	-

Note

- Usage above the absolute maximum conditions listed in **Table 3** may cause permanent damage to the device. Exposure to Absolute Maximum conditions for extended periods of time may affect device reliability. The Maximum Storage Temperature is 150 °C in compliance with JEDEC Standard JESD22-A103, High Temperature Storage Life. When used below Absolute Maximum conditions but above normal operating conditions, the device may not operate to specification.

8.2 Device-level specifications

All specifications are valid for $-40\text{ °C} \leq T_A \leq 85\text{ °C}$ for Grade-A devices, $-40\text{ °C} \leq T_A \leq 105\text{ °C}$ for Grade-S devices, and $-40\text{ °C} \leq T_A \leq 125\text{ °C}$ for Grade-E devices. Specifications are valid for 1.71 V to 5.5 V, except where noted.

Table 4 DC specifications

Typical values measured at $V_{DD} = 3.3\text{ V}$ and 25 °C .

Spec ID#	Parameter	Description	Min	Typ	Max	Unit	Details/Conditions
SID53	V_{DD}	Power supply input voltage	1.8	–	5.5	V	Internally regulated supply
SID255	V_{DD}	Power supply input voltage ($V_{CCD} = V_{DDD} = V_{DDA}$)	1.71	–	1.89		Internally unregulated supply
SID54	V_{CCD}	Output voltage (for core logic)	–	1.8	–		–
SID55	C_{EFC}	External regulator voltage bypass	–	0.1	–	μF	X5R ceramic or better
SID56	C_{EXC}	Power supply bypass capacitor	–	1	–		X5R ceramic or better
Active Mode, $V_{DD} = 1.8\text{ V}$ to 5.5 V. Typical values measured at $V_{DD} = 3.3\text{ V}$ and 25 °C.							
SID10	I_{DD5}	Execute from flash; CPU at 6 MHz	–	1.8	2.7	mA	Max is at 125 °C and 5.5 V
SID16	I_{DD8}	Execute from flash; CPU at 24 MHz	–	3.0	5		Max is at 125 °C and 5.5 V
SID19	I_{DD11}	Execute from flash; CPU at 48 MHz	–	5.4	7.6		Max is at 125 °C and 5.5 V
Sleep Mode, $V_{DDD} = 1.8\text{ V}$ to 5.5 V (Regulator on)							
SID22	I_{DD17}	I ² C wakeup WDT, and Comparators on	–	1.1	2.2	mA	6 MHz. Max is at 125 °C and 5.5 V
SID25	I_{DD20}	I ² C wakeup, WDT, and Comparators on	–	1.5	2.5		12 MHz. Max is at 125 °C and 5.5 V
Sleep Mode, $V_{DDD} = 1.71\text{ V}$ to 1.89 V (Regulator bypassed)							
SID28	I_{DD23}	I ² C wakeup, WDT, and Comparators on	–	1.1	1.8	mA	6 MHz. Max is at 125 °C and 1.89 V .
SID28A	I_{DD23A}	I ² C wakeup, WDT, and Comparators on	–	1.5	2.1		12 MHz. Max is at 125 °C and 1.89 V .
Deep Sleep Mode, $V_{DD} = 1.8\text{ V}$ to 3.6 V (Regulator on)							
SID30	I_{DD25}	I ² C wakeup and WDT on	–	2.5	40	μA	$T = -40\text{ °C}$ to 60 °C
SID31	I_{DD26}	I ² C wakeup and WDT on	–	2.5	350		Max is at 3.6 V and 125 °C
Deep Sleep Mode, $V_{DD} = 3.6\text{ V}$ to 5.5 V (Regulator on)							
SID33	I_{DD28}	I ² C wakeup and WDT on	–	2.5	40	μA	$T = -40\text{ °C}$ to 60 °C
SID34	I_{DD29}	I ² C wakeup and WDT on	–	2.5	350		Max is at 5.5 V and 125 °C
Deep Sleep Mode, $V_{DD} = V_{CCD} = 1.71\text{ V}$ to 1.89 V (Regulator bypassed)							
SID36	I_{DD31}	I ² C wakeup and WDT on	–	2.5	60	μA	$T = -40\text{ °C}$ to 60 °C
SID37	I_{DD32}	I ² C wakeup and WDT on	–	2.5	400		Max is at 125 °C and 1.89 V
XRES Current							
SID307	I_{DD_XR}	Supply current while XRES asserted	–	2	5	mA	–

Electrical specifications

Table 5 AC specifications

Spec ID#	Parameter	Description	Min	Typ	Max	Unit	Details/Conditions
SID48	F _{CPU}	CPU frequency	DC	–	48	MHz	1.71 ≤ V _{DD} ≤ 5.5
SID49	T _{SLEEP}	Wakeup from Sleep mode	–	0	–	μs	–
SID50	T _{DEEPSLEEP}	Wakeup from Deep Sleep mode	–	35	–		–

8.2.1 GPIO

Table 6 GPIO DC specifications

Spec ID#	Parameter	Description	Min	Typ	Max	Unit	Details/Conditions	
SID57	V _{IH} ^[2]	Input voltage high threshold	0.7 × V _{DDD}	–	–	V	CMOS Input	
SID58	V _{IL}	Input voltage low threshold	–	–	0.3 × V _{DDD}		CMOS Input	
SID241	V _{IH} ^[2]	LVTTL input, V _{DDD} < 2.7 V	0.7 × V _{DDD}	–	–		–	
SID242	V _{IL}	LVTTL input, V _{DDD} < 2.7 V	–	–	0.3 × V _{DDD}		–	
SID243	V _{IH} ^[2]	LVTTL input, V _{DDD} ≥ 2.7 V	2.0	–	–		–	
SID244	V _{IL}	LVTTL input, V _{DDD} ≥ 2.7 V	–	–	0.8		–	
SID59	V _{OH}	Output voltage high level	V _{DDD} – 0.6	–	–		I _{OH} = 4 mA at 3 V V _{DDD}	
SID60	V _{OH}	Output voltage high level	V _{DDD} – 0.5	–	–		I _{OH} = 1 mA at 1.8 V V _{DDD}	
SID61	V _{OL}	Output voltage low level	–	–	0.6		I _{OL} = 4 mA at 1.8 V V _{DDD}	
SID62	V _{OL}	Output voltage low level	–	–	0.6		I _{OL} = 10 mA at 3 V V _{DDD}	
SID62A	V _{OL}	Output voltage low level	–	–	0.4		I _{OL} = 3 mA at 3 V V _{DDD}	
SID63	R _{PULLUP}	Pull-up resistor	3.5	5.6	8.5		kΩ	–
SID64	R _{PULLDOWN}	Pull-down resistor	3.5	5.6	8.5			–
SID65	I _{IL}	Input leakage current (absolute value)	–	–	2		nA	25 °C, V _{DDD} = 3.0 V
SID66	C _{IN}	Input capacitance	–	–	7	pF	–	
SID67 ^[3]	V _{HYSTTL}	Input hysteresis LVTTL	25	40	–	mV	V _{DDD} ≥ 2.7 V	
SID68 ^[3]	V _{HYSCMOS}	Input hysteresis CMOS	0.05 × V _{DDD}	–	–		V _{DD} < 4.5 V	
SID68A ^[3]	V _{HYSCMOS5V5}	Input hysteresis CMOS	200	–	–		V _{DD} > 4.5 V	
SID69 ^[3]	I _{DIODE}	Current through protection diode to V _{DD} /V _{SS}	–	–	100	μA	–	
SID69A ^[3]	I _{TOT_GPIO}	Maximum total source or sink chip current	–	–	200	mA	–	

Notes

2. V_{IH} must not exceed V_{DDD} + 0.2 V.
3. Guaranteed by characterization.

Electrical specifications

Table 7 **GPIO AC specifications**
(Guaranteed by Characterization)

Spec ID#	Parameter	Description	Min	Typ	Max	Unit	Details/Conditions
SID70	T _{RISEF}	Rise time in fast strong mode	2	–	12	ns	3.3 V V _{DD} , Cl _{oad} = 25 pF
SID71	T _{FALLF}	Fall time in fast strong mode	2	–	12		3.3 V V _{DD} , Cl _{oad} = 25 pF
SID72	T _{RISES}	Rise time in slow strong mode	10	–	60	–	3.3 V V _{DD} , Cl _{oad} = 25 pF
SID73	T _{FALLS}	Fall time in slow strong mode	10	–	60	–	3.3 V V _{DD} , Cl _{oad} = 25 pF
SID74	F _{GPIOUT1}	GPIO F _{OUT} ; 3.3 V ≤ V _{DD} ≤ 5.5 V Fast strong mode	–	–	33	MHz	90/10%, 25 pF load, 60/40 duty cycle
SID75	F _{GPIOUT2}	GPIO F _{OUT} ; 1.71 V ≤ V _{DD} ≤ 3.3 V Fast strong mode	–	–	16.7		90/10%, 25 pF load, 60/40 duty cycle
SID76	F _{GPIOUT3}	GPIO F _{OUT} ; 3.3 V ≤ V _{DD} ≤ 5.5 V Slow strong mode	–	–	7		90/10%, 25 pF load, 60/40 duty cycle
SID245	F _{GPIOUT4}	GPIO F _{OUT} ; 1.71 V ≤ V _{DD} ≤ 3.3 V Slow strong mode.	–	–	3.5		90/10%, 25 pF load, 60/40 duty cycle
SID246	F _{GPIOIN}	GPIO input operating frequency; 1.71 V ≤ V _{DD} ≤ 5.5 V	–	–	48		90/10% V _{IO}

Electrical specifications

8.2.2 XRES

Table 8 XRES DC specifications

Spec ID#	Parameter	Description	Min	Typ	Max	Unit	Details/Conditions
SID77	V _{IH}	Input voltage high threshold	0.7 × V _{DD}	–	–	V	CMOS Input
SID78	V _{IL}	Input voltage low threshold	–	–	0.3 × V _{DD}		
SID79	R _{PULLUP}	Pull-up resistor	–	60	–	kΩ	–
SID80	C _{IN}	Input capacitance	–	–	7	pF	–
SID81 ^[4]	V _{HYSXRES}	Input voltage hysteresis	–	100	–	mV	Typical hysteresis is 200 mV for V _{DD} > 4.5 V
SID82	I _{DIODE}	Current through protection diode to V _{DD} /V _{SS}	–	–	100	μA	–

Table 9 XRES AC Specifications

Spec ID#	Parameter	Description	Min	Typ	Max	Unit	Details/Conditions
SID83 ^[4]	T _{RESETWIDTH}	Reset pulse width	1	–	–	μs	–
BID194 ^[4]	T _{RESETWAKE}	Wake-up time from reset release	–	–	2.7	ms	–

Note

4. Guaranteed by characterization.

Electrical specifications

8.3 Analog peripherals

8.3.1 CTBm opamp

Table 10 CTBm opamp specifications

Spec ID#	Parameter	Description	Min	Typ	Max	Units	Details/Conditions
	I_{DD}	Opamp block current, External load					
SID269	I_{DD_HI}	power = hi	-	1100	1850	μA	-
SID270	I_{DD_MED}	power = med	-	550	950		-
SID271	I_{DD_LOW}	power = lo	-	150	350		-
	G_{BW}	Load = 20 pF, 0.1 mA $V_{DDA} = 2.7 V$					
SID272	G_{BW_HI}	power = hi	6	-	-	MHz	Input and output are 0.2 V to $V_{DDA}-0.2 V$
SID273	G_{BW_MED}	power = med	3	-	-		Input and output are 0.2 V to $V_{DDA}-0.2 V$
SID274	G_{BW_LO}	power = lo	-	1	-		Input and output are 0.2 V to $V_{DDA}-0.2 V$
	I_{OUT_MAX}	$V_{DDA} = 2.7 V$, 500 mV from rail					
SID275	$I_{OUT_MAX_HI}$	power = hi	10	-	-	mA	Output is 0.5 V to $V_{DDA} -0.5 V$
SID276	$I_{OUT_MAX_MID}$	power = mid	10	-	-		Output is 0.5 V to $V_{DDA} -0.5 V$
SID277	$I_{OUT_MAX_LO}$	power = lo	-	5	-		Output is 0.5 V to $V_{DDA} -0.5 V$
	I_{OUT}	$V_{DDA} = 1.71 V$, 500 mV from rail					
SID278	$I_{OUT_MAX_HI}$	power = hi	4	-	-	mA	Output is 0.5 V to $V_{DDA} -0.5 V$
SID279	$I_{OUT_MAX_MID}$	power = mid	4	-	-		Output is 0.5 V to $V_{DDA}-0.5 V$
SID280	$I_{OUT_MAX_LO}$	power = lo	-	2	-		Output is 0.5 V to $V_{DDA}-0.5 V$
	I_{DD_Int}	Opamp block current Internal Load					
SID269_I	$I_{DD_HI_Int}$	power = hi	-	1500	1700	μA	-
SID270_I	$I_{DD_MED_Int}$	power = med	-	700	900		-
SID271_I	$I_{DD_LOW_Int}$	power = lo	-	-	-		-
	G_{BW}	$V_{DDA} = 2.7 V$	-	-	-		-
SID272_I	$G_{BW_HI_Int}$	power = hi	8	-	-	MHz	Output is 0.25 V to $V_{DDA}-0.25 V$

Electrical specifications

Table 10 CTBm opamp specifications (continued)

Spec ID#	Parameter	Description	Min	Typ	Max	Units	Details/Conditions
		General opamp specs for both internal and external modes					
SID281	V_{IN}	Charge-pump on, $V_{DDA} = 2.7\text{ V}$	-0.05	-	$V_{DDA}-0.2$	V	-
SID282	V_{CM}	Charge-pump on, $V_{DDA} = 2.7\text{ V}$	-0.05	-	$V_{DDA}-0.2$		-
	V_{OUT}	$V_{DDA} = 2.7\text{ V}$					
SID283	V_{OUT_1}	power = hi, Iload=10 mA	0.5	-	$V_{DDA} - 0.5$	V	-
SID284	V_{OUT_2}	power = hi, Iload=1 mA	0.2	-	$V_{DDA} - 0.2$		-
SID285	V_{OUT_3}	power = med, Iload=1 mA	0.2	-	$V_{DDA} - 0.2$		-
SID286	V_{OUT_4}	power = lo, Iload=0.1 mA	0.2	-	$V_{DDA} - 0.2$		-
SID288	V_{OS_TR}	Offset voltage, trimmed	-1.0	± 0.5	1.0	mV	High mode, input 0 V to $V_{DDA}-0.2\text{ V}$
SID288A	V_{OS_TR}	Offset voltage, trimmed	-	± 1.4	-		Medium mode, input 0 V to $V_{DDA}-0.2\text{ V}$
SID288B	V_{OS_TR}	Offset voltage, trimmed	-	± 2	-		Low mode, input 0 V to $V_{DDA}-0.2\text{ V}$
SID290	$V_{OS_DR_TR}$	Offset voltage drift, trimmed	-10	± 3	10	$\mu\text{V}/^\circ\text{C}$	High mode
SID290A	$V_{OS_DR_TR}$	Offset voltage drift, trimmed	-	± 10	-	$\mu\text{V}/^\circ\text{C}$	Medium mode
SID290B	$V_{OS_DR_TR}$	Offset voltage drift, trimmed	-	± 10	-		Low mode
SID291	CMRR	DC	70	80	-	dB	Input is 0 V to $V_{DDA}-0.2\text{ V}$, Output is 0.2 V to $V_{DDA}-0.2\text{ V}$
SID292	PSRR	At 1 kHz, 10-mV ripple	70	85	-		$V_{DD} = 3.6\text{ V}$, high-power mode, input is 0.2 V to $V_{DDA}-0.2\text{ V}$

Electrical specifications

Table 10 CTBm opamp specifications (continued)

Spec ID#	Parameter	Description	Min	Typ	Max	Units	Details/Conditions
	Noise						
SID294	VN2	Input-referred, 1 kHz, power = Hi	-	72	-	nV/ rtHz	3
SID295	VN3	Input-referred, 10 kHz, power = Hi	-	28	-		Input and output are at 0.2 V to $V_{DDA}-0.2$ V
SID296	VN4	Input-referred, 100 kHz, power = Hi	-	15	-		Input and output are at 0.2 V to $V_{DDA}-0.2$ V
SID297	C _{LOAD}	Stable up to max. load. Performance specs at 50 pF.	-	-	125	pF	-
SID298	SLEW_RATE	Clod = 50 pF, Power = High, $V_{DDA} = 2.7$ V	6	-	-	V/ μ s	-
SID299	T _{OP_WAKE}	From disable to enable, no external RC dominating	-	-	25	μ s	-
SID299A	OL_GAIN	Open Loop Gain	-	90	-	dB	
	COMP_MODE	Comparator mode; 50 mV drive, $T_{rise}=T_{fall}$ (approx.)					
SID300	TPD1	Response time; power = hi	-	150	-	ns	Input is 0.2 V to $V_{DDA}-0.2$ V
SID301	TPD2	Response time; power = med	-	500	-		Input is 0.2 V to $V_{DDA}-0.2$ V
SID302	TPD3	Response time; power = lo	-	2500	-		Input is 0.2 V to $V_{DDA}-0.2$ V
SID303	VHYST_OP	Hysteresis	-	10	-	mV	-
SID304	WUP_CTB	Wake-up time from Enabled to Usable	-	-	25	μ s	-
	Deep Sleep Mode	Mode 2 is lowest current range. Mode 1 has higher GBW.					
SID_DS_1	I _{DD_HI_M1}	Mode 1, High current	-	1400	-	μ A	25 °C
SID_DS_2	I _{DD_MED_M1}	Mode 1, Medium current	-	700	-		25 °C
SID_DS_3	I _{DD_LOW_M1}	Mode 1, Low current	-	200	-		25 °C
SID_DS_4	I _{DD_HI_M2}	Mode 2, High current	-	120	-		25 °C
SID_DS_5	I _{DD_MED_M2}	Mode 2, Medium current	-	60	-		25 °C
SID_DS_6	I _{DD_LOW_M2}	Mode 2, Low current	-	15	-		25 °C

Electrical specifications

Table 10 CTBm opamp specifications (continued)

Spec ID#	Parameter	Description	Min	Typ	Max	Units	Details/Conditions
SID_DS_7	G _{BW_HI_M1}	Mode 1, High current	-	4	-	MHz	20-pF load, no DC load 0.2 V to V _{DDA} - 0.2 V
SID_DS_8	G _{BW_MED_M1}	Mode 1, Medium current	-	2	-		20-pF load, no DC load 0.2 V to V _{DDA} - 0.2 V
SID_DS_9	G _{BW_LOW_M1}	Mode 1, Low current	-	0.5	-		20-pF load, no DC load 0.2 V to V _{DDA} - 0.2 V
SID_DS_10	G _{BW_HI_M2}	Mode 2, High current	-	0.5	-		20-pF load, no DC load 0.2 V to V _{DDA} - 0.2 V
SID_DS_11	G _{BW_MED_M2}	Mode 2, Medium current	-	0.2	-		20-pF load, no DC load 0.2 V to V _{DDA} - 0.2 V
SID_DS_12	G _{BW_LOW_M2}	Mode 2, Low current	-	0.1	-		20-pF load, no DC load 0.2 V to V _{DDA} - 0.2 V
SID_DS_13	V _{OS_HI_M1}	Mode 1, High current	-	5	-	mV	With trim 25 °C, 0.2 V to V _{DDA} - 0.2 V
SID_DS_14	V _{OS_MED_M1}	Mode 1, Medium current	-	5	-		With trim 25 °C, 0.2 V to V _{DDA} - 0.2 V
SID_DS_15	V _{OS_LOW_M2}	Mode 1, Low current	-	5	-		With trim 25 °C, 0.2 V to V _{DDA} - 0.2 V
SID_DS_16	V _{OS_HI_M2}	Mode 2, High current	-	5	-		With trim 25 °C, 0.2 V to V _{DDA} - 0.2 V
SID_DS_17	V _{OS_MED_M2}	Mode 2, Medium current	-	5	-		With trim 25 °C, 0.2 V to V _{DDA} - 0.2 V
SID_DS_18	V _{OS_LOW_M2}	Mode 2, Low current	-	5	-		With trim 25 °C, 0.2 V to V _{DDA} - 0.2 V

Electrical specifications

Table 10 CTBm opamp specifications (continued)

Spec ID#	Parameter	Description	Min	Typ	Max	Units	Details/Conditions
SID_DS_19	I _{OUT_HI_M1}	Mode 1, High current	-	10	-	mA	Output is 0.5 V to V _{DDA} - 0.5 V
SID_DS_20	I _{OUT_MED_M1}	Mode 1, Medium current	-	10	-		Output is 0.5 V to V _{DDA} - 0.5 V
SID_DS_21	I _{OUT_LOW_M1}	Mode 1, Low current	-	4	-		Output is 0.5 V to V _{DDA} - 0.5 V
SID_DS_22	I _{OUT_HI_M2}	Mode 2, High current	-	1	-		-
SID_DS_23	I _{OU_MED_M2}	Mode 2, Medium current	-	1	-		-
SID_DS_24	I _{OU_LOW_M2}	Mode 2, Low current	-	0.5	-		-

Electrical specifications

8.3.2 Comparator

Table 11 Comparator DC specifications

Spec ID#	Parameter	Description	Min	Typ	Max	Units	Details/Conditions
SID84	V _{OFFSET1}	Input offset voltage, Factory trim	-	-	±10	mV	-
SID85	V _{OFFSET2}	Input offset voltage, Custom trim	-	-	±4		-
SID86	V _{HYST}	Hysteresis when enabled	-	10	35		-
SID87	V _{ICM1}	Input common mode voltage in normal mode	0	-	V _{DDD} -0.1	V	Modes 1 and 2
SID247	V _{ICM2}	Input common mode voltage in low power mode	0	-	V _{DDD}		-
SID247A	V _{ICM3}	Input common mode voltage in ultra low power mode	0	-	V _{DDD} -1.15		V _{DDD} ≥ 2.2 V at -40 °C
SID88	C _{MRR}	Common mode rejection ratio	50	-	-	dB	V _{DDD} ≥ 2.7V
SID88A	C _{MRR}	Common mode rejection ratio	42	-	-		V _{DDD} ≤ 2.7V
SID89	I _{CMP1}	Block current, normal mode	-	-	400	μA	-
SID248	I _{CMP2}	Block current, low power mode	-	-	100		-
SID259	I _{CMP3}	Block current in ultra low-power mode	-	-	6		V _{DDD} ≥ 2.2 V at -40 °C
SID90	Z _{CMP}	DC Input impedance of comparator	35	-	-	MΩ	-

Table 12 Comparator AC Specifications

Spec ID#	Parameter	Description	Min	Typ	Max	Unit	Details/Conditions
SID91	TRESP1	Response time, normal mode, 50 mV overdrive	-	38	110	ns	-
SID258	TRESP2	Response time, low power mode, 50 mV overdrive	-	70	200		-
SID92	TRESP3	Response time, ultra-low power mode, 200 mV overdrive	-	2.3	15	μs	V _{DDD} ≥ 2.2 V at -40 °C

Electrical specifications

8.3.3 Temperature sensor

Table 13 Temperature Sensor Specifications

Spec ID#	Parameter	Description	Min	Typ	Max	Unit	Details/Conditions
SID93	TSENSACC	Temperature sensor accuracy	-5	±1	5	°C	-40 to +85 °C
SID93A	TSENSACC	Temperature sensor accuracy	-15	±1	+15	°C	+85 to +150 °C

8.3.4 SAR ADC

Table 14 SAR ADC specifications

Spec ID#	Parameter	Description	Min	Typ	Max	Unit	Details/Conditions
SAR ADC DC specifications							
SID94	A_RES	Resolution	-	-	12	bits	-
SID95	A_CHNLS_S	Number of channels - single ended	-	-	16		-
SID96	A-CHNKS_D	Number of channels - differential	-	-	4		Diff inputs use neighboring I/O
SID97	A-MONO	Monotonicity	-	-	-		Yes
SID98	A_GAINERR	Gain error	-	-	±0.1	%	With external reference
SID99	A_OFFSET	Input offset voltage	-	-	2	mV	Measured with 1 V reference
SID100	A_ISAR	Current consumption	-	-	1	mA	-
SID101	A_VINS	Input voltage range - single ended	V _{SS}	-	V _{DDA}	V	-
SID102	A_VIND	Input voltage range - differential	V _{SS}	-	V _{DDA}	V	-
SID103	A_INRES	Input resistance	-	-	2.2	KΩ	-
SID104	A_INCAP	Input capacitance	-	-	10	pF	-
SID260	VREFSAR	Trimmed internal reference to SAR	1.188	1.2	1.212	V	-
SAR ADC AC specifications							
SID106	A_PSRR	Power supply rejection ratio	70	-	-	dB	-
SID107	A_CMRR	Common mode rejection ratio	66	-	-	dB	Measured at 1 V
SID108	A_SAMP	Sample rate	-	-	1	Msp/s	-
SID109	A_SNR	Signal-to-noise and distortion ratio (SINAD)	65	-	-	dB	F _{IN} = 10 kHz
SID110	A_BW	Input bandwidth without aliasing	-	-	A _{samp} /2	kHz	-
SID111	A_INL	Integral non linearity. V _{DD} = 1.71 to 5.5, 1 Msp/s	-1.7	-	2	LSB	V _{REF} = 1 to V _{DD}
SID111A	A_INL	Integral non linearity. V _{DD} = 1.71 to 3.6, 1 Msp/s	-1.5	-	1.7	LSB	V _{REF} = 1.71 to V _{DD}
SID111B	A_INL	Integral non linearity. V _{DD} = 1.71 to 5.5, 500 ksp/s	-1.5	-	1.7	LSB	V _{REF} = 1 to V _{DD}

Electrical specifications

Table 14 SAR ADC specifications (continued)

Spec ID#	Parameter	Description	Min	Typ	Max	Unit	Details/Conditions
SID112	A_DNL	Differential non linearity. $V_{DD} = 1.71$ to 5.5 , 1 Msps	-1	-	2.2	LSB	$V_{REF} = 1$ to V_{DD}
SID112A	A_DNL	Differential non linearity. $V_{DD} = 1.71$ to 3.6 , 1 Msps	-1	-	2	LSB	$V_{REF} = 1.71$ to V_{DD}
SID112B	A_DNL	Differential non linearity. $V_{DD} = 1.71$ to 5.5 , 500 ksps	-1	-	2.2	LSB	$V_{REF} = 1$ to V_{DD}
SID113	A_THD	Total harmonic distortion	-	-	-65	dB	$f_{in} = 10$ kHz
SID261	FSARINTREF	SAR operating speed without external reference bypass	-	-	100	ksps	12-bit resolution

8.3.5 CSD and IDAC

Table 15 CSD and IDAC Specifications

Spec ID#	Parameter	Description	Min	Typ	Max	Unit	Details/Conditions
SYS.PER#3	VDD_RIPPLE	Max allowed ripple on power supply, DC to 10 MHz	-	-	± 50	mV	$V_{DD} > 2$ V (with ripple), 25°C T_A , Sensitivity = 0.1 pF
SYS.PER#16	VDD_RIPPLE_1.8	Max allowed ripple on power supply, DC to 10 MHz	-	-	± 25	mV	$V_{DD} > 1.75$ V (with ripple), 25°C T_A , Parasitic Capacitance (C_p) < 20 pF, Sensitivity ≥ 0.4 pF
SID.CSD.BLK	ICSD	Maximum block current	-	-	4000	μA	Maximum block current for both IDACs in dynamic (switching) mode including comparators, buffer, and reference generator
SID.CSD#15	V_{REF}	Voltage reference for CSD and Comparator	0.6	1.2	$V_{DDA} - 0.6$	V	$V_{DDA} - 0.06$ or 4.4, whichever is lower
SID.CSD#15A	VREF_EXT	External Voltage reference for CSD and Comparator	0.6	-	$V_{DDA} - 0.6$	V	$V_{DDA} - 0.06$ or 4.4, whichever is lower
SID.CSD#16	IDAC1IDD	IDAC1 (7-bits) block current	-	-	1750	μA	-
SID.CSD#17	IDAC2IDD	IDAC2 (7-bits) block current	-	-	1750	μA	-
SID308	VCSD	Voltage range of operation	1.71	-	5.5	V	1.8 V $\pm 5\%$ or 1.8 V to 5.5 V
SID308A	VCOMPIDAC	Voltage compliance range of IDAC	0.6	-	$V_{DDA} - 0.6$	V	$V_{DDA} - 0.06$ or 4.4, whichever is lower
SID309	IDAC1DNL	DNL	-1	-	1	LSB	-
SID310	IDAC1INL	INL	-2	-	2	LSB	INL is ± 5.5 LSB for $V_{DDA} < 2$ V
SID311	IDAC2DNL	DNL	-1	-	1	LSB	-
SID312	IDAC2INL	INL	-2	-	2	LSB	INL is ± 5.5 LSB for $V_{DDA} < 2$ V
SID313	SNR	Ratio of counts of finger to noise. Guaranteed by characterization	5	-	-	Ratio	Capacitance range of 5 to 35 pF, 0.1-pF sensitivity. All use cases. $V_{DDA} > 2$ V.

Electrical specifications

Table 15 CSD and IDAC Specifications (continued)

Spec ID#	Parameter	Description	Min	Typ	Max	Unit	Details/Conditions
SID314	IDAC1CRT1	Output current of IDAC1 (7 bits) in low range	4.2	-	5.4	μA	LSB = 37.5 nA typ
SID314A	IDAC1CRT2	Output current of IDAC1(7 bits) in medium range	34	-	41	μA	LSB = 300 nA typ
SID314B	IDAC1CRT3	Output current of IDAC1(7 bits) in high range	275	-	330	μA	LSB = 2.4 μA typ
SID314C	IDAC1CRT12	Output current of IDAC1 (7 bits) in low range, 2X mode	8	-	10.5	μA	LSB = 75 nA typ
SID314D	IDAC1CRT22	Output current of IDAC1(7 bits) in medium range, 2X mode	69	-	82	μA	LSB = 600 nA typ.
SID314E	IDAC1CRT32	Output current of IDAC1(7 bits) in high range, 2X mode	540	-	660	μA	LSB = 4.8 μA typ
SID315	IDAC2CRT1	Output current of IDAC2 (7 bits) in low range	4.2	-	5.4	μA	LSB = 37.5 nA typ
SID315A	IDAC2CRT2	Output current of IDAC2 (7 bits) in medium range	34	-	41	μA	LSB = 300 nA typ
SID315B	IDAC2CRT3	Output current of IDAC2 (7 bits) in high range	275	-	330	μA	LSB = 2.4 μA typ
SID315C	IDAC2CRT12	Output current of IDAC2 (7 bits) in low range, 2X mode	8	-	10.5	μA	LSB = 75 nA typ
SID315D	IDAC2CRT22	Output current of IDAC2(7 bits) in medium range, 2X mode	69	-	82	μA	LSB = 600 nA typ
SID315E	IDAC2CRT32	Output current of IDAC2(7 bits) in high range, 2X mode	540	-	660	μA	LSB = 4.8 μA typ
SID315F	IDAC3CRT13	Output current of IDAC in 8-bit mode in low range	8	-	10.5	μA	LSB = 37.5 nA typ
SID315G	IDAC3CRT23	Output current of IDAC in 8-bit mode in medium range	69	-	82	μA	LSB = 300 nA typ
SID315H	IDAC3CRT33	Output current of IDAC in 8-bit mode in high range	540	-	660	μA	LSB = 2.4 μA typ
SID320	IDACOFFSET	All zeroes input	-	-	1	LSB	Polarity set by Source or Sink. Offset is 2 LSBs for 37.5 nA/LSB mode
SID321	IDACGAIN	Full-scale error less offset	-	-	±10	%	-
SID322	IDACMISMATCH1	Mismatch between IDAC1 and IDAC2 in Low mode	-	-	9.2	LSB	LSB = 37.5 nA typ
SID322A	IDACMISMATCH2	Mismatch between IDAC1 and IDAC2 in Medium mode	-	-	5.6	LSB	LSB = 300 nA typ
SID322B	IDACMISMATCH3	Mismatch between IDAC1 and IDAC2 in High mode	-	-	6.8	LSB	LSB = 2.4 μA typ
SID323	IDACSET8	Settling time to 0.5 LSB for 8-bit IDAC	-	-	5	μs	Full-scale transition. No external load
SID324	IDACSET7	Settling time to 0.5 LSB for 7-bit IDAC	-	-	5	μs	Full-scale transition. No external load
SID325	CMOD	External modulator capacitor.	-	2.2	-	nF	5-V rating, X7R or NP0 cap

Electrical specifications

8.3.6 10-bit CAPSENSE™ ADC

Table 16 10-bit CAPSENSE™ ADC Specifications

Spec ID#	Parameter	Description	Min	Typ	Max	Unit	Details/Conditions
SIDA94	A_RES	Resolution	-	-	10	bits	Auto-zeroing is required every millisecond
SIDA95	A_CHNLS_S	Number of channels - single ended	-	-	16		Defined by AMUX Bus
SIDA97	A-MONO	Monotonicity	-	-	-	Yes	-
SIDA98	A_GAINERR	Gain error	-	-	±3	%	In V_{REF} (2.4 V) mode with V_{DDA} bypass capacitance of 10 μ F
SIDA99	A_OFFSET	Input offset voltage	-	-	±18	mV	In V_{REF} (2.4 V) mode with V_{DDA} bypass capacitance of 10 μ F
SIDA101	A_VINS	Input voltage range - single ended	V_{SSA}	-	V_{DDA}	V	-
SIDA103	A_INRES	Input resistance	-	2.2	-	K Ω	-
SIDA104	A_INCAP	Input capacitance	-	20	-	pF	-
SIDA106	A_PSR	Power supply rejection ratio	-	60	-	dB	In V_{REF} (2.4 V) mode with V_{DDA} bypass capacitance of 10 μ F
SIDA107	A_TACQ	Sample acquisition time	-	1	-	μ s	-
SIDA108	A_CONV8	Conversion time for 8-bit resolution at conversion rate = $F_{hclk}/(2^{(N+2)})$. Clock frequency = 48 MHz.	-	-	21.3	μ s	Does not include acquisition time. Equivalent to 44.8 ksp/s including acquisition time.
SIDA108A	A_CONV10	Conversion time for 10-bit resolution at conversion rate = $F_{hclk}/(2^{(N+2)})$. Clock frequency = 48 MHz.	-	-	85.3	μ s	Does not include acquisition time. Equivalent to 11.6 ksp/s including acquisition time.
SIDA109	A_SND	Signal-to-noise and Distortion ratio (SINAD)	-	61	-	dB	With 10-Hz input sine wave, external 2.4-V reference, V_{REF} (2.4 V) mode
SIDA110	A_BW	Input bandwidth without aliasing	-	-	22.4	KHz	8-bit resolution
SIDA111	A_INL	Integral Non Linearity. 1 ksp/s	-	-	2	LSB	$V_{REF} = 2.4$ V or greater
SIDA112	A_DNL	Differential Non Linearity. 1 ksp/s	-	-	1		-

Electrical specifications

8.4 Digital peripherals

8.4.1 Timer counter pulse-width modulator (TCPWM)

Table 17 TCPWM specifications

Spec ID	Parameter	Description	Min	Typ	Max	Units	Details/Conditions
SID.TCPWM.1	ITCPWM1	Block current consumption at 3 MHz	-	-	45	μ A	All modes (TCPWM)
SID.TCPWM.2	ITCPWM2	Block current consumption at 12 MHz	-	-	155		All modes (TCPWM)
SID.TCPWM.2A	ITCPWM3	Block current consumption at 48 MHz	-	-	650		All modes (TCPWM)
SID.TCPWM.3	TCPWM _{FREQ}	Operating frequency	-	-	Fc	MHz	Fc max = CLK_SYS Maximum = 48 MHz
SID.TCPWM.4	TPWM _{ENEXT}	Input trigger pulse width	2/Fc	-	-	ns	For all trigger events ^[5]
SID.TCPWM.5	TPWM _{EXT}	Output trigger pulse widths	2/Fc	-	-		Minimum possible width of Overflow, Underflow, and CC (Counter equals Compare value) outputs
SID.TCPWM.5A	TC _{RES}	Resolution of counter	1/Fc	-	-		Minimum time between successive counts
SID.TCPWM.5B	PWM _{RES}	PWM resolution	1/Fc	-	-		Minimum pulse width of PWM Output
SID.TCPWM.5C	Q _{RES}	Quadrature inputs resolution	1/Fc	-	-		Minimum pulse width between Quadrature phase inputs

Electrical specifications

8.4.2 I²C

Table 18 Fixed I²C DC Specifications^[5]

Spec ID#	Parameter	Description	Min	Typ	Max	Unit	Details/Conditions
SID149	I _{I2C1}	Block current consumption at 100 kHz	-	-	50	μA	-
SID150	I _{I2C2}	Block current consumption at 400 kHz	-	-	135		-
SID151	I _{I2C3}	Block current consumption at 1 Mbps	-	-	310		-
SID152	I _{I2C4}	I ² C enabled in Deep Sleep mode	-	1	-		-

Table 19 Fixed I²C AC Specifications^[5]

Spec ID#	Parameter	Description	Min	Typ	Max	Unit	Details/Conditions
SID153	F _{I2C1}	Bit rate	-	-	1	Msp/s	-

Note

Electrical specifications

8.4.3 SPI

Table 20 SPI DC specifications^[6]

Spec ID#	Parameter	Description	Min	Typ	Max	Unit	Details/Conditions
SID163	ISPI1	Block current consumption at 1 Mbps	-	-	360	μA	-
SID164	ISPI2	Block current consumption at 4 Mbps	-	-	560		-
SID165	ISPI3	Block current consumption at 8 Mbps	-	-	600		-

Table 21 SPI AC Specifications^[6]

Spec ID#	Parameter	Description	Min	Typ	Max	Unit	Details/Conditions
SID166	FSPI	SPI Operating frequency (Master; 6X Oversampling)	-	-	8	MHz	-

Fixed SPI Master Mode AC Specifications

SID167	TDMO	MOSI Valid after SClk driving edge	-	-	15	ns	-
SID168	TDSI	MISO Valid before SClk capturing edge	20	-	-		Full clock, late MISO sampling
SID169	THMO	Previous MOSI data hold time	0	-	-		Referred to Slave capturing edge

Fixed SPI Slave Mode AC Specifications

SID170	TDMI	MOSI Valid before Sclck Capturing edge	40	-	-	ns	-
SID171	TDSO	MISO Valid after Sclck driving edge	-	-	$42 + (3 \times T_{cpu})$		$T_{CPU} = 1/F_{CPU}$
SID171A	TDSO_EXT	MISO Valid after Sclck driving edge in Ext. Clk mode	-	-	48		-
SID172	THSO	Previous MISO data hold time	0	-	-		-
SID172A	TSSELSSCK	SSEL Valid to first SCK Valid edge	-	-	100	ns	-

Electrical specifications

8.4.4 UART

Table 22 UART DC specifications^[6]

Spec ID#	Parameter	Description	Min	Typ	Max	Unit	Details/Conditions
SID160	I _{UART1}	Block current consumption at 100 Kbps	–	–	55	μA	–
SID161	I _{UART2}	Block current consumption at 1000 Kbps	–	–	312	μA	–

Table 23 UART AC Specifications^[6]

Spec ID#	Parameter	Description	Min	Typ	Max	Unit	Details/Conditions
SID162	F _{UART}	Bit rate	–	–	1	Mbps	–

8.4.5 LCD Direct Drive

Table 24 LCD Direct Drive DC Specifications^[6]

Spec ID#	Parameter	Description	Min	Typ	Max	Unit	Details/Conditions
SID154	I _{LCDLOW}	Operating current in low power mode	–	5	–	μA	16 × 4 small segment disp. at 50 Hz
SID155	C _{LDCAP}	LCD capacitance per segment/common driver	–	500	5000	pF	–
SID156	LCD _{OFFSET}	Long-term segment offset	–	20	–	mV	–
SID157	I _{LCDOP1}	LCD system operating current V _{bias} = 5 V	–	2	–	mA	32 × 4 segments at 50 Hz 25 °C
SID158	I _{LCDOP2}	LCD system operating current V _{bias} = 3.3 V	–	2	–		32 × 4 segments at 50 Hz 25 °C

Table 25 LCD Direct Drive AC Specifications^[6]

Spec ID#	Parameter	Description	Min	Typ	Max	Unit	Details/Conditions
SID159	F _{LCD}	LCD frame rate	10	50	150	Hz	–

Note

6. Guaranteed by characterization.

Electrical specifications

8.5 Memory

8.5.1 Flash

Table 26 Flash DC Specifications

Spec ID#	Parameter	Description	Min	Typ	Max	Unit	Details/Conditions
SID173	V _{PE}	Erase and program voltage	1.71	-	5.5	V	-

Table 27 Flash AC Specifications

Spec ID#	Parameter	Description	Min	Typ	Max	Unit	Details/Conditions
SID174	T _{ROWWRITE} ^[7]	Row (block) write time (erase and program)	-	-	20	ms	Row (block) = 256 bytes
SID175	T _{ROWERASE} ^[7]	Row erase time	-	-	16		-
SID176	T _{ROWPROGRAM} ^[7]	Row program time after erase	-	-	4		-
SID178	T _{BULKERASE} ^[7]	Bulk erase time (64 KB)	-	-	35		-
SID180 ^[7]	T _{DEVPROG} ^[7]	Total device program time	-	-	7	Seconds	-
SID181 ^[7]	F _{END}	Flash endurance	100K	-	-	Cycles	-
SID182 ^[7]	F _{RET}	Flash retention. T _A ≤ 55 °C, 100K P/E cycles	20	-	-	Years	-
SID182A ^[7]	F _{RET}	Flash retention. T _A ≤ 85 °C, 10K P/E cycles	10	-	-		-
SID182B	F _{RETQ}	Flash retention. T _A ≤ 105 °C, 10K P/E cycles with no more than 3 years at T _A > 85 °C	10	-	-		Guaranteed by design
SID256	TWS48	Number of Wait states at 48 MHz	2	-	-		CPU execution from Flash
SID257	TWS24	Number of Wait states at 24 MHz	1	-	-		CPU execution from Flash

Note

7. It can take as much as 20 milliseconds to write to Flash. During this time the device should not be Reset, or Flash operations will be interrupted and cannot be relied on to have completed. Reset sources include the XRES pin, software resets, CPU lockup states and privilege violations, improper power supply levels, and watchdogs. Make certain that these are not inadvertently activated.

8.6 System resources

8.6.1 Power-on reset (POR)

Table 28 Power-on reset (PRES)

Spec ID#	Parameter	Description	Min	Typ	Max	Units	Details/Conditions
SID.CLK#6	SR_POWER	Power supply slew rate	1 ^[8]	–	67	V/ms	On power-up and power-down
SID185 ^[9]	V _{RISEIPOR}	Rising trip voltage	0.80	–	1.5	V	–
SID186 ^[9]	V _{FALLIPOR}	Falling trip voltage	0.70	–	1.4		–

8.6.2 Brown-out detect (BOD)

Table 29 Brown-out detect (BOD) for V_{CCD}

Spec ID#	Parameter	Description	Min	Typ	Max	Unit	Details/Conditions
SID190 ^[9]	V _{FALLPPOR}	BOD trip voltage in active and sleep modes	1.48	–	1.62	V	–
SID192 ^[9]	V _{FALLDPSLP}	BOD trip voltage in Deep Sleep	1.11	–	1.5		–

8.6.3 SWD interface

Table 30 SWD interface specifications

Spec ID#	Parameter	Description	Min	Typ	Max	Unit	Details/Conditions
SID213	F_SWDCCLK1	$3.3\text{ V} \leq V_{DD} \leq 5.5\text{ V}$	–	–	14	MHz	SWDCCLK \leq 1/3 CPU clock frequency
SID214	F_SWDCCLK2	$1.71\text{ V} \leq V_{DD} \leq 3.3\text{ V}$	–	–	7		SWDCCLK \leq 1/3 CPU clock frequency
SID215 ^[9]	T_SWDI_SETUP	$T = 1/f\text{ SWDCCLK}$	$0.25 \times T$	–	–	ns	–
SID216 ^[9]	T_SWDI_HOLD	$T = 1/f\text{ SWDCCLK}$	$0.25 \times T$	–	–		–
SID217 ^[9]	T_SWDO_VALID	$T = 1/f\text{ SWDCCLK}$	–	–	$0.5 \times T$		–
SID217A ^[9]	T_SWDO_HOLD	$T = 1/f\text{ SWDCCLK}$	1	–	–		–

Notes

- If minimum ramp rate cannot be met, XRES should be asserted during voltage ramp ($1.5\text{ V} > V_{DD} > 1.0\text{ V}$ for ramp-down or until voltage is stable for ramp-up). Note that a glitch on the I2C bus could occur during voltage ramp in this case.
- Guaranteed by characterization.

Electrical specifications

8.6.4 Internal main oscillator

Table 31 IMO DC specifications

(Guaranteed by design)

Spec ID#	Parameter	Description	Min	Typ	Max	Unit	Details/Conditions
SID218	I _{IMO1}	IMO operating current at 48 MHz	–	–	250	μA	–
SID219	I _{IMO2}	IMO operating current at 24 MHz	–	–	180	μA	–

Table 32 IMO AC Specifications

Spec ID#	Parameter	Description	Min	Typ	Max	Unit	Details/Conditions
SID223	F _{IMOTOL1}	Frequency variation at 24, 32, and 48 MHz (trimmed)	–	–	±2	%	–40 °C ≤ TA ≤ 105 °C
SID223A	F _{IMOTOL1A}	Frequency variation at 24, 32, and 48 MHz (trimmed)	–	–	±2.5	%	–40 °C ≤ TA ≤ 125 °C
SID333	IMO _{WCO}	All IMO settings	–	–	±0.25	%	IMO variation in WCO-locked DPLL mode
SID226	T _{STARTIMO}	IMO startup time	–	–	7	μs	–
SID228	T _{JITRMSIMO2}	RMS jitter at 24 MHz	–	145	–	ps	–

Electrical specifications

8.6.5 Internal low-speed oscillator

Table 33 ILO DC specifications

(Guaranteed by Design)

Spec ID#	Parameter	Description	Min	Typ	Max	Unit	Details/Conditions
SID231	I _{ILO1}	ILO operating current	–	0.3	1.05	µA	–

Table 34 ILO AC Specifications

Spec ID#	Parameter	Description	Min	Typ	Max	Unit	Details/Conditions
SID234 ^[10]	T _{STARTILO1}	ILO startup time	–	–	2	ms	–
SID236 ^[10]	T _{ILODUTY}	ILO duty cycle	40	50	60	%	–
SID237	F _{ILOTRIM1}	ILO frequency range	20	40	80	kHz	–

8.6.6 Watch crystal oscillator (WCO)

Table 35 WCO specifications

Spec ID#	Parameter	Description	Min	Typ	Max	Unit	Details/Conditions
SID398	FWCO	Crystal frequency	–	32.768	–	kHz	–
SID399	FTOL	Frequency tolerance	–	50	250	ppm	With 20-ppm crystal
SID400	ESR	Equivalent series resistance	–	50	–	kΩ	–
SID401	PD	Drive Level	–	–	1	µW	–
SID402	TSTART	Startup time	–	–	500	ms	–
SID403	CL	Crystal Load Capacitance	6	–	12.5	pF	–
SID404	C0	Crystal Shunt Capacitance	–	1.35	–	pF	–
SID405	IWCO1	Operating Current (high power mode)	–	–	8	µA	–

8.6.7 External clock

Table 36 External clock specifications

Spec ID#	Parameter	Description	Min	Typ	Max	Unit	Details/Conditions
SID305 ^[11]	ExtClkFreq	External clock input frequency	0	–	48	MHz	–40 °C ≤ TA ≤ 85 °C
SID306 ^[11]	ExtClkDuty	Duty cycle; measured at V _{DD/2}	45	–	55	%	–40 °C ≤ TA ≤ 85 °C

Notes

- 10.Guaranteed by characterization.
- 11.Guaranteed by design.

8.6.8 External crystal oscillator and PLL

Table 37 External crystal oscillator (ECO) specifications

Spec ID#	Parameter	Description	Min	Typ	Max	Unit	Details/Conditions
SID316 ^[12]	IECO1	External clock input frequency	-	-	1.5	mA	-
SID317 ^[12]	FECO	Crystal frequency range	4	-	33	MHz	-

Table 38 PLL Specifications

Spec ID#	Parameter	Description	Min	Typ	Max	Unit	Details/Conditions
SID410	IDD_PLL_48	In = 3 MHz, Out = 48 MHz	-	530	610	μA	-
SID411	IDD_PLL_24	In = 3 MHz, Out = 24 MHz	-	300	405	μA	-
SID412	Fpplin	PLL input frequency	1	-	48	MHz	-
SID413	Fpplint	PLL intermediate frequency; prescaler out	1	-	3	MHz	-
SID414	Fpllvco	VCO output frequency before post-divide	22.5	-	104	MHz	-
SID415	Divvco	VCO Output post-divider range; PLL output frequency is Fpplvco/Divvco	1	-	8		-
SID416	Pllocktime	Lock time at startup	-	-	250	μs	-
SID417	Jperiod_1	Period jitter for VCO ≥ 67 MHz	-	-	150	ps	Guaranteed by design -40 °C ≤ TA ≤ 85 °C
SID416A	Jperiod_2	Period jitter for VCO ≤ 67 MHz	-	-	200	ps	Guaranteed by design -40 °C ≤ TA ≤ 85 °C

8.6.9 System clock

Table 39 Block specs

Spec ID#	Parameter	Description	Min	Typ	Max	Unit	Details/Conditions
SID262 ^[12]	T _{CLKSWITCH}	System clock source switching time	3	-	4	Periods	-

Electrical specifications

8.6.10 Smart I/O

Table 40 Smart I/O pass-through time (Delay in Bypass Mode)

Spec ID#	Parameter	Description	Min	Typ	Max	Unit	Details/Conditions
SID252	PRG_BYPASS	Max delay added by Smart I/O in bypass mode	-	-	1.6	ns	-

8.6.11 CAN

Table 41 CAN specifications

Spec ID#	Parameter	Description	Min	Typ	Max	Unit	Details/Conditions
SID420	IDD_CAN	Block current consumption	-	-	200	μA	-
SID421	CAN_bits	CAN Bit rate	-	-	1	Mbps	Min 8-MHz clock

Note

12. Guaranteed by characterization.



9 Ordering information

Table 42 lists the marketing part numbers (MPNs) for the PSoC 4100S Plus devices^[13].

Table 42 Ordering information

MPN	Features															Packages				Operating Temp			
	Max CPU Speed (MHz)	Flash (KB)	SRAM (KB)	UDB	Opamp (CTBm)	CAPSENSE™	Direct LCD Drive	12-bit SAR ADC	LP Comparators	TCPWM Blocks	SCB Blocks	WCO	ECO	Smart IOs	CAN	GPIO	40-QFN	48-QFN	64-WQFN	64-TQFP	-40 to +85C	-40 to +105C	-40 to +125C
CY8C4126LDA-S453KA	24	64	8	-	2	X	X	806 Ksps	2	8	4	X	X	24	-	38	X			X			
CY8C4146LDA-S243KA	48	64	8	-	-	-	-	1000 Ksps	2	8	4	X	X	24	-	38	X			X			
CY8C4146LDA-S253KA	48	64	8	-	-	-	X	1000 Ksps	2	8	4	X	X	24	-	38	X			X			
CY8C4146LDA-S263KA	48	64	8	-	-	X	-	1000 Ksps	2	8	4	X	X	24	-	38	X			X			
CY8C4146LDA-S273KA	48	64	8	-	-	X	X	1000 Ksps	2	8	4	X	X	24	-	38	X			X			
CY8C4146LDA-S453KA	48	64	8	-	2	X	X	1000 Ksps	2	8	4	X	X	24	-	38	X			X			
CY8C4127LDA-S443KA	24	128	16	-	2	-	X	806 Ksps	2	8	4	X	X	24	-	38	X			X			
CY8C4127LDA-S453KA	24	128	16	-	2	X	X	806 Ksps	2	8	4	X	X	24	-	38	X			X			
CY8C4147LDA-S243KA	48	128	16	-	-	-	-	1000 Ksps	2	8	4	X	X	24	-	38	X			X			
CY8C4147LDA-S253KA	48	128	16	-	-	-	X	1000 Ksps	2	8	4	X	X	24	-	38	X			X			
CY8C4147LDA-S263KA	48	128	16	-	-	X	-	1000 Ksps	2	8	4	X	X	24	-	38	X			X			
CY8C4147LDA-S273KA	48	128	16	-	-	X	X	1000 Ksps	2	8	4	X	X	24	-	38	X			X			
CY8C4147LDA-S283KA	48	128	16	-	-	-	X	1000 Ksps	2	8	4	X	X	24	1	38	X			X			
CY8C4147LDA-S293KA	48	128	16	-	-	X	X	1000 Ksps	2	8	4	X	X	24	1	38	X			X			
CY8C4147LDA-S443KA	48	128	16	-	2	-	X	1000 Ksps	2	8	4	X	X	24	-	38	X			X			
CY8C4147LDA-S453KA	48	128	16	-	2	X	X	1000 Ksps	2	8	4	X	X	24	-	38	X			X			
CY8C4147LDA-S463KA	48	128	16	-	2	-	X	1000 Ksps	2	8	4	X	X	24	1	38	X			X			
CY8C4147LDA-S473KA	48	128	16	-	2	X	X	1000 Ksps	2	8	4	X	X	24	1	38	X			X			

Note
13. Contact Cypress for the availability of Grade-E devices



Table 42 Ordering information (continued)

MPN	Features															Packages				Operating Temp				
	Max CPU Speed (MHz)	Flash (KB)	SRAM (KB)	UDB	Opamp (CTBm)	CAPSENSE™	Direct LCD Drive	12-bit SAR ADC	LP Comparators	TCPWM Blocks	SCB Blocks	WCO	ECO	Smart I/Os	CAN	GPIO	40-QFN	48-QFN	64-WQFN	64-TQFP	-40 to +85C	-40 to +105C	-40 to +125C	
CY8C4126LDS-S453KA	24	64	8	-	2	X	X	806 Ksps	2	8	4	X	X	24	-	38	X					X		
CY8C4146LDS-S243KA	48	64	8	-	-	-	-	1000 Ksps	2	8	4	X	X	24	-	38	X					X		
CY8C4146LDS-S253KA	48	64	8	-	-	-	X	1000 Ksps	2	8	4	X	X	24	-	38	X					X		
CY8C4146LDS-S263KA	48	64	8	-	-	X	-	1000 Ksps	2	8	4	X	X	24	-	38	X					X		
CY8C4146LDS-S273KA	48	64	8	-	-	X	X	1000 Ksps	2	8	4	X	X	24	-	38	X					X		
CY8C4146LDS-S453KA	48	64	8	-	2	X	X	1000 Ksps	2	8	4	X	X	24	-	38	X					X		
CY8C4127LDS-S443KA	24	128	16	-	2	-	X	806 Ksps	2	8	4	X	X	24	-	38	X					X		
CY8C4127LDS-S453KA	24	128	16	-	2	X	X	806 Ksps	2	8	4	X	X	24	-	38	X					X		
CY8C4147LDS-S243KA	48	128	16	-	-	-	-	1000 Ksps	2	8	4	X	X	24	-	38	X					X		
CY8C4147LDS-S253KA	48	128	16	-	-	-	X	1000 Ksps	2	8	4	X	X	24	-	38	X					X		
CY8C4147LDS-S263KA	48	128	16	-	-	X	-	1000 Ksps	2	8	4	X	X	24	-	38	X					X		
CY8C4147LDS-S273KA	48	128	16	-	-	X	X	1000 Ksps	2	8	4	X	X	24	-	38	X					X		
CY8C4147LDS-S283KA	48	128	16	-	-	-	X	1000 Ksps	2	8	4	X	X	24	1	38	X					X		
CY8C4147LDS-S293KA	48	128	16	-	-	X	X	1000 Ksps	2	8	4	X	X	24	1	38	X					X		
CY8C4147LDS-S443KA	48	128	16	-	2	-	X	1000 Ksps	2	8	4	X	X	24	-	38	X					X		
CY8C4147LDS-S453KA	48	128	16	-	2	X	X	1000 Ksps	2	8	4	X	X	24	-	38	X					X		
CY8C4147LDS-S463KA	48	128	16	-	2	-	X	1000 Ksps	2	8	4	X	X	24	1	38	X					X		
CY8C4147LDS-S473KA	48	128	16	-	2	X	X	1000 Ksps	2	8	4	X	X	24	1	38	X					X		
CY8C4126LDE-S453KA	24	64	8	-	2	X	X	806 Ksps	2	8	4	X	X	24	-	38	X							X
CY8C4146LDE-S243KA	48	64	8	-	-	-	-	1000 Ksps	2	8	4	X	X	24	-	38	X							X
CY8C4146LDE-S253KA	48	64	8	-	-	-	X	1000 Ksps	2	8	4	X	X	24	-	38	X							X
CY8C4146LDE-S263KA	48	64	8	-	-	X	-	1000 Ksps	2	8	4	X	X	24	-	38	X							X
CY8C4146LDE-S273KA	48	64	8	-	-	X	X	1000 Ksps	2	8	4	X	X	24	-	38	X							X



Table 42 Ordering information (continued)

MPN	Features															Packages				Operating Temp			
	Max CPU Speed (MHz)	Flash (KB)	SRAM (KB)	UDB	Opamp (CTBm)	CAPSENSE™	Direct LCD Drive	12-bit SAR ADC	LP Comparators	TCPWM Blocks	SCB Blocks	WCO	ECO	Smart I/Os	CAN	GPIO	40-QFN	48-QFN	64-WQFN	64-TQFP	-40 to +85C	-40 to +105C	-40 to +125C
CY8C4146LDE-S453KA	48	64	8	-	2	X	X	1000 Ksps	2	8	4	X	X	24	-	38	X						X
CY8C4127LDE-S443KA	24	128	16	-	2	-	X	806 Ksps	2	8	4	X	X	24	-	38	X						X
CY8C4127LDE-S453KA	24	128	16	-	2	X	X	806 Ksps	2	8	4	X	X	24	-	38	X						X
CY8C4147LDE-S243KA	48	128	16	-	-	-	-	1000 Ksps	2	8	4	X	X	24	-	38	X						X
CY8C4147LDE-S253KA	48	128	16	-	-	-	X	1000 Ksps	2	8	4	X	X	24	-	38	X						X
CY8C4147LDE-S263KA	48	128	16	-	-	X	-	1000 Ksps	2	8	4	X	X	24	-	38	X						X
CY8C4147LDE-S273KA	48	128	16	-	-	X	X	1000 Ksps	2	8	4	X	X	24	-	38	X						X
CY8C4147LDE-S283KA	48	128	16	-	-	-	X	1000 Ksps	2	8	4	X	X	24	1	38	X						X
CY8C4147LDE-S293KA	48	128	16	-	-	X	X	1000 Ksps	2	8	4	X	X	24	1	38	X						X
CY8C4147LDE-S443KA	48	128	16	-	2	-	X	1000 Ksps	2	8	4	X	X	24	-	38	X						X
CY8C4147LDE-S453KA	48	128	16	-	2	X	X	1000 Ksps	2	8	4	X	X	24	-	38	X						X
CY8C4147LDE-S463KA	48	128	16	-	2	-	X	1000 Ksps	2	8	4	X	X	24	1	38	X						X
CY8C4147LDE-S473KA	48	128	16	-	2	X	X	1000 Ksps	2	8	4	X	X	24	1	38	X						X
CY8C4126AZA-S455	24	64	8	-	2	X	X	806 Ksps	2	8	5	X	X	24	-	54				X	X		
CY8C4146AZA-S245	48	64	8	-	-	-	-	1000 Ksps	2	8	5	X	X	24	-	54				X	X		
CY8C4146AZA-S255	48	64	8	-	-	-	X	1000 Ksps	2	8	5	X	X	24	-	54				X	X		
CY8C4146AZA-S265	48	64	8	-	-	X	-	1000 Ksps	2	8	5	X	X	24	-	54				X	X		
CY8C4146AZA-S275	48	64	8	-	-	X	X	1000 Ksps	2	8	5	X	X	24	-	54				X	X		
CY8C4146AZA-S455	48	64	8	-	2	X	X	1000 Ksps	2	8	5	X	X	24	-	54				X	X		
CY8C4127AZA-S445	24	128	16	-	2	-	X	806 Ksps	2	8	5	X	X	24	-	54				X	X		
CY8C4127AZA-S455	24	128	16	-	2	X	X	806 Ksps	2	8	5	X	X	24	-	54				X	X		
CY8C4147AZA-S245	48	128	16	-	-	-	-	1000 Ksps	2	8	5	X	X	24	-	54				X	X		
CY8C4147AZA-S255	48	128	16	-	-	-	X	1000 Ksps	2	8	5	X	X	24	-	54				X	X		



Table 42 Ordering information (continued)

MPN	Features															Packages				Operating Temp			
	Max CPU Speed (MHz)	Flash (KB)	SRAM (KB)	UDB	Opamp (CTBm)	CAPSENSE™	Direct LCD Drive	12-bit SAR ADC	LP Comparators	TCPWM Blocks	SCB Blocks	WCO	ECO	Smart IOs	CAN	GPIO	40-QFN	48-QFN	64-WQFN	64-TQFP	-40 to +85C	-40 to +105C	-40 to +125C
CY8C4147AZA-S265	48	128	16	-	-	X	-	1000 Ksps	2	8	5	X	X	24	-	54			X	X			
CY8C4147AZA-S275	48	128	16	-	-	X	X	1000 Ksps	2	8	5	X	X	24	-	54			X	X			
CY8C4147AZA-S285	48	128	16	-	-	-	X	1000 Ksps	2	8	5	X	X	24	1	54			X	X			
CY8C4147AZA-S295	48	128	16	-	-	X	X	1000 Ksps	2	8	5	X	X	24	1	54			X	X			
CY8C4147AZA-S445	48	128	16	-	2	-	X	1000 Ksps	2	8	5	X	X	24	-	54			X	X			
CY8C4147AZA-S455	48	128	16	-	2	X	X	1000 Ksps	2	8	5	X	X	24	-	54			X	X			
CY8C4147AZA-S465	48	128	16	-	2	-	X	1000 Ksps	2	8	5	X	X	24	1	54			X	X			
CY8C4147AZA-S475	48	128	16	-	2	X	X	1000 Ksps	2	8	5	X	X	24	1	54			X	X			
CY8C4126AZS-S455	24	64	8	-	2	X	X	806 Ksps	2	8	5	X	X	24	-	54			X		X		
CY8C4146AZS-S245	48	64	8	-	-	-	-	1000 Ksps	2	8	5	X	X	24	-	54			X		X		
CY8C4146AZS-S255	48	64	8	-	-	-	X	1000 Ksps	2	8	5	X	X	24	-	54			X		X		
CY8C4146AZS-S265	48	64	8	-	-	X	-	1000 Ksps	2	8	5	X	X	24	-	54			X		X		
CY8C4146AZS-S275	48	64	8	-	-	X	X	1000 Ksps	2	8	5	X	X	24	-	54			X		X		
CY8C4146AZS-S455	48	64	8	-	2	X	X	1000 Ksps	2	8	5	X	X	24	-	54			X		X		
CY8C4127AZS-S445	24	128	16	-	2	-	X	806 Ksps	2	8	5	X	X	24	-	54			X		X		
CY8C4127AZS-S455	24	128	16	-	2	X	X	806 Ksps	2	8	5	X	X	24	-	54			X		X		
CY8C4147AZS-S245	48	128	16	-	-	-	-	1000 Ksps	2	8	5	X	X	24	-	54			X		X		
CY8C4147AZS-S255	48	128	16	-	-	-	X	1000 Ksps	2	8	5	X	X	24	-	54			X		X		
CY8C4147AZS-S265	48	128	16	-	-	X	-	1000 Ksps	2	8	5	X	X	24	-	54			X		X		
CY8C4147AZS-S275	48	128	16	-	-	X	X	1000 Ksps	2	8	5	X	X	24	-	54			X		X		
CY8C4147AZS-S285	48	128	16	-	-	-	X	1000 Ksps	2	8	5	X	X	24	1	54			X		X		
CY8C4147AZS-S295	48	128	16	-	-	X	X	1000 Ksps	2	8	5	X	X	24	1	54			X		X		
CY8C4147AZS-S445	48	128	16	-	2	-	X	1000 Ksps	2	8	5	X	X	24	-	54			X		X		



Table 42 Ordering information (continued)

MPN	Features															Packages				Operating Temp			
	Max CPU Speed (MHz)	Flash (KB)	SRAM (KB)	UDB	Opamp (CTBm)	CAPSENSE™	Direct LCD Drive	12-bit SAR ADC	LP Comparators	TCPWM Blocks	SCB Blocks	WCO	ECO	Smart I/Os	CAN	GPIO	40-QFN	48-QFN	64-WQFN	64-TQFP	-40 to +85C	-40 to +105C	-40 to +125C
CY8C4147AZS-S455	48	128	16	-	2	X	X	1000 Ksps	2	8	5	X	X	24	-	54			X		X		
CY8C4147AZS-S465	48	128	16	-	2	-	X	1000 Ksps	2	8	5	X	X	24	1	54			X		X		
CY8C4147AZS-S475	48	128	16	-	2	X	X	1000 Ksps	2	8	5	X	X	24	1	54			X		X		
CY8C4126LQA-S453	24	64	8	-	2	X	X	806 Ksps	2	8	4	X	X	24	-	34	X				X		
CY8C4146LQA-S243	48	64	8	-	-	-	-	1000 Ksps	2	8	4	X	X	24	-	34	X				X		
CY8C4146LQA-S253	48	64	8	-	-	-	X	1000 Ksps	2	8	4	X	X	24	-	34	X				X		
CY8C4146LQA-S263	48	64	8	-	-	X	-	1000 Ksps	2	8	4	X	X	24	-	34	X				X		
CY8C4146LQA-S273	48	64	8	-	-	X	X	1000 Ksps	2	8	4	X	X	24	-	34	X				X		
CY8C4146LQA-S453	48	64	8	-	2	X	X	1000 Ksps	2	8	4	X	X	24	-	34	X				X		
CY8C4127LQA-S443	24	128	16	-	2	-	X	806 Ksps	2	8	4	X	X	24	-	34	X				X		
CY8C4127LQA-S453	24	128	16	-	2	X	X	806 Ksps	2	8	4	X	X	24	-	34	X				X		
CY8C4147LQA-S243	48	128	16	-	-	-	-	1000 Ksps	2	8	4	X	X	24	-	34	X				X		
CY8C4147LQA-S253	48	128	16	-	-	-	X	1000 Ksps	2	8	4	X	X	24	-	34	X				X		
CY8C4147LQA-S263	48	128	16	-	-	X	-	1000 Ksps	2	8	4	X	X	24	-	34	X				X		
CY8C4147LQA-S273	48	128	16	-	-	X	X	1000 Ksps	2	8	4	X	X	24	-	34	X				X		
CY8C4147LQA-S283	48	128	16	-	-	-	X	1000 Ksps	2	8	4	X	X	24	1	34	X				X		
CY8C4147LQA-S293	48	128	16	-	-	X	X	1000 Ksps	2	8	4	X	X	24	1	34	X				X		
CY8C4147LQA-S443	48	128	16	-	2	-	X	1000 Ksps	2	8	4	X	X	24	-	34	X				X		
CY8C4147LQA-S453	48	128	16	-	2	X	X	1000 Ksps	2	8	4	X	X	24	-	34	X				X		
CY8C4147LQA-S463	48	128	16	-	2	-	X	1000 Ksps	2	8	4	X	X	24	1	34	X				X		
CY8C4147LQA-S473	48	128	16	-	2	X	X	1000 Ksps	2	8	4	X	X	24	1	34	X				X		
CY8C4126LQS-S453	24	64	8	-	2	X	X	806 Ksps	2	8	4	X	X	24	-	34	X					X	
CY8C4146LQS-S243	48	64	8	-	-	-	-	1000 Ksps	2	8	4	X	X	24	-	34	X					X	



Table 42 Ordering information (continued)

MPN	Features															Packages				Operating Temp			
	Max CPU Speed (MHz)	Flash (KB)	SRAM (KB)	UDB	Opamp (CTBm)	CAPSENSE™	Direct LCD Drive	12-bit SAR ADC	LP Comparators	TCPWM Blocks	SCB Blocks	WCO	ECO	Smart I/Os	CAN	GPIO	40-QFN	48-QFN	64-WQFN	64-TQFP	-40 to +85C	-40 to +105C	-40 to +125C
CY8C4146LQS-S253	48	64	8	-	-	-	X	1000 Ksps	2	8	4	X	X	24	-	34	X					X	
CY8C4146LQS-S263	48	64	8	-	-	X	-	1000 Ksps	2	8	4	X	X	24	-	34	X					X	
CY8C4146LQS-S273	48	64	8	-	-	X	X	1000 Ksps	2	8	4	X	X	24	-	34	X					X	
CY8C4146LQS-S453	48	64	8	-	2	X	X	1000 Ksps	2	8	4	X	X	24	-	34	X					X	
CY8C4127LQS-S443	24	128	16	-	2	-	X	806 Ksps	2	8	4	X	X	24	-	34	X					X	
CY8C4127LQS-S453	24	128	16	-	2	X	X	806 Ksps	2	8	4	X	X	24	-	34	X					X	
CY8C4147LQS-S243	48	128	16	-	-	-	-	1000 Ksps	2	8	4	X	X	24	-	34	X					X	
CY8C4147LQS-S253	48	128	16	-	-	-	X	1000 Ksps	2	8	4	X	X	24	-	34	X					X	
CY8C4147LQS-S263	48	128	16	-	-	X	-	1000 Ksps	2	8	4	X	X	24	-	34	X					X	
CY8C4147LQS-S273	48	128	16	-	-	X	X	1000 Ksps	2	8	4	X	X	24	-	34	X					X	
CY8C4147LQS-S283	48	128	16	-	-	-	X	1000 Ksps	2	8	4	X	X	24	1	34	X					X	
CY8C4147LQS-S293	48	128	16	-	-	X	X	1000 Ksps	2	8	4	X	X	24	1	34	X					X	
CY8C4147LQS-S443	48	128	16	-	2	-	X	1000 Ksps	2	8	4	X	X	24	-	34	X					X	
CY8C4147LQS-S453	48	128	16	-	2	X	X	1000 Ksps	2	8	4	X	X	24	-	34	X					X	
CY8C4147LQS-S463	48	128	16	-	2	-	X	1000 Ksps	2	8	4	X	X	24	1	34	X					X	
CY8C4147LQS-S473	48	128	16	-	2	X	X	1000 Ksps	2	8	4	X	X	24	1	34	X					X	
CY8C4126LQE-S453	24	64	8	-	2	X	X	806 Ksps	2	8	4	X	X	24	-	34	X						X
CY8C4146LQE-S243	48	64	8	-	-	-	-	1000 Ksps	2	8	4	X	X	24	-	34	X						X
CY8C4146LQE-S253	48	64	8	-	-	-	X	1000 Ksps	2	8	4	X	X	24	-	34	X						X
CY8C4146LQE-S263	48	64	8	-	-	X	-	1000 Ksps	2	8	4	X	X	24	-	34	X						X
CY8C4146LQE-S273	48	64	8	-	-	X	X	1000 Ksps	2	8	4	X	X	24	-	34	X						X
CY8C4146LQE-S453	48	64	8	-	2	X	X	1000 Ksps	2	8	4	X	X	24	-	34	X						X
CY8C4127LQE-S443	24	128	16	-	2	-	X	806 Ksps	2	8	4	X	X	24	-	34	X						X



Table 42 Ordering information (continued)

MPN	Features															Packages				Operating Temp				
	Max CPU Speed (MHz)	Flash (KB)	SRAM (KB)	UDB	Opamp (CTBm)	CAPSENSE™	Direct LCD Drive	12-bit SAR ADC	LP Comparators	TCPWM Blocks	SCB Blocks	WCO	ECO	Smart I/Os	CAN	GPIO	40-QFN	48-QFN	64-WQFN	64-TQFP	-40 to +85C	-40 to +105C	-40 to +125C	
CY8C4127LQE-S453	24	128	16	-	2	X	X	806 Ksps	2	8	4	X	X	24	-	34	X							X
CY8C4147LQE-S243	48	128	16	-	-	-	-	1000 Ksps	2	8	4	X	X	24	-	34	X							X
CY8C4147LQE-S253	48	128	16	-	-	-	X	1000 Ksps	2	8	4	X	X	24	-	34	X							X
CY8C4147LQE-S263	48	128	16	-	-	X	-	1000 Ksps	2	8	4	X	X	24	-	34	X							X
CY8C4147LQE-S273	48	128	16	-	-	X	X	1000 Ksps	2	8	4	X	X	24	-	34	X							X
CY8C4147LQE-S283	48	128	16	-	-	-	X	1000 Ksps	2	8	4	X	X	24	1	34	X							X
CY8C4147LQE-S293	48	128	16	-	-	X	X	1000 Ksps	2	8	4	X	X	24	1	34	X							X
CY8C4147LQE-S443	48	128	16	-	2	-	X	1000 Ksps	2	8	4	X	X	24	-	34	X							X
CY8C4147LQE-S453	48	128	16	-	2	X	X	1000 Ksps	2	8	4	X	X	24	-	34	X							X
CY8C4147LQE-S463	48	128	16	-	2	-	X	1000 Ksps	2	8	4	X	X	24	1	34	X							X
CY8C4147LQE-S473	48	128	16	-	2	X	X	1000 Ksps	2	8	4	X	X	24	1	34	X							X
CY8C4126AZE-S455	24	64	8		2	X	X	806 Ksps	2	8	5	X	X	24	-	54				X				X
CY8C4146AZE-S245	48	64	8			-		1000 Ksps	2	8	5	X	X		-	54				X				X
CY8C4146AZE-S255	48	64	8			-	X	1000 Ksps	2	8	5	X	X		-	54				X				X
CY8C4146AZE-S265	48	64	8			X		1000 Ksps	2	8	5	X	X		-	54				X				X
CY8C4146AZE-S275	48	64	8			X	X	1000 Ksps	2	8	5	X	X		-	54				X				X
CY8C4146AZE-S455	48	64	8		2	X	X	1000 Ksps	2	8	5	X	X	24	-	54				X				X
CY8C4127AZE-S445	24	128	16		2	-	X	806 Ksps	2	8	5	X	X	24	-	54				X				X
CY8C4127AZE-S455	24	128	16		2	X	X	806 Ksps	2	8	5	X	X	24	-	54				X				X
CY8C4147AZE-S245	48	128	16			-		1000 Ksps	2	8	5	X	X		-	54				X				X
CY8C4147AZE-S255	48	128	16			-	X	1000 Ksps	2	8	5	X	X		-	54				X				X
CY8C4147AZE-S265	48	128	16			X		1000 Ksps	2	8	5	X	X		-	54				X				X
CY8C4147AZE-S275	48	128	16			X	X	1000 Ksps	2	8	5	X	X		-	54				X				X



Table 42 Ordering information (continued)

MPN	Features															Packages				Operating Temp			
	Max CPU Speed (MHz)	Flash (KB)	SRAM (KB)	UDB	Opamp (CTBm)	CAPSENSE™	Direct LCD Drive	12-bit SAR ADC	LP Comparators	TCPWM Blocks	SCB Blocks	WCO	ECO	Smart IOs	CAN	GPIO	40-QFN	48-QFN	64-WQFN	64-TQFP	-40 to +85C	-40 to +105C	-40 to +125C
CY8C4147AZE-S285	48	128	16			-	X	1000 Ksps	2	8	5	X	X	24	1	54			X				X
CY8C4147AZE-S295	48	128	16			X	X	1000 Ksps	2	8	5	X	X	24	1	54			X				X
CY8C4147AZE-S445	48	128	16		2	-	X	1000 Ksps	2	8	5	X	X	24	-	54			X				X
CY8C4147AZE-S455	48	128	16		2	X	X	1000 Ksps	2	8	5	X	X	24	-	54			X				X
CY8C4147AZE-S465	48	128	16		2	-	X	1000 Ksps	2	8	5	X	X	24	1	54			X				X
CY8C4147AZE-S475	48	128	16		2	X	X	1000 Ksps	2	8	5	X	X	24	1	54			X				X
CY8C4126LQA-S455	24	64	8		2	X	X	806 Ksps	2	8	5	X	X	24	-	54		X		X			
CY8C4146LQA-S245	48	64	8		-	-	-	1000 Ksps	2	8	5	X	X	24	-	54			X		X		
CY8C4146LQA-S255	48	64	8		-	-	X	1000 Ksps	2	8	5	X	X	24	-	54			X		X		
CY8C4146LQA-S265	48	64	8		-	X	-	1000 Ksps	2	8	5	X	X	24	-	54			X		X		
CY8C4146LQA-S275	48	64	8		-	X	X	1000 Ksps	2	8	5	X	X	24	-	54			X		X		
CY8C4146LQA-S455	48	64	8		2	X	X	1000 Ksps	2	8	5	X	X	24	-	54			X		X		
CY8C4127LQA-S445	24	128	16		2	-	X	806 Ksps	2	8	5	X	X	24	-	54			X		X		
CY8C4127LQA-S455	24	128	16		2	X	X	806 Ksps	2	8	5	X	X	24	-	54			X		X		
CY8C4147LQA-S245	48	128	16		-	-	-	1000 Ksps	2	8	5	X	X	24	-	54			X		X		
CY8C4147LQA-S255	48	128	16		-	-	X	1000 Ksps	2	8	5	X	X	24	-	54			X		X		
CY8C4147LQA-S265	48	128	16		-	X	-	1000 Ksps	2	8	5	X	X	24	-	54			X		X		
CY8C4147LQA-S275	48	128	16		-	X	X	1000 Ksps	2	8	5	X	X	24	-	54			X		X		
CY8C4147LQA-S285	48	128	16		-	-	X	1000 Ksps	2	8	5	X	X	24	1	54			X		X		
CY8C4147LQA-S295	48	128	16		-	X	X	1000 Ksps	2	8	5	X	X	24	1	54			X		X		
CY8C4147LQA-S445	48	128	16		2	-	X	1000 Ksps	2	8	5	X	X	24	-	54			X		X		
CY8C4147LQA-S455	48	128	16		2	X	X	1000 Ksps	2	8	5	X	X	24	-	54			X		X		
CY8C4147LQA-S465	48	128	16		2	-	X	1000 Ksps	2	8	5	X	X	24	1	54			X		X		



Table 42 Ordering information (continued)

MPN	Features															Packages				Operating Temp			
	Max CPU Speed (MHz)	Flash (KB)	SRAM (KB)	UDB	Opamp (CTBm)	CAPSENSE™	Direct LCD Drive	12-bit SAR ADC	LP Comparators	TCPWM Blocks	SCB Blocks	WCO	ECO	Smart I/Os	CAN	GPIO	40-QFN	48-QFN	64-WQFN	64-TQFP	-40 to +85C	-40 to +105C	-40 to +125C
CY8C4147LQA-S475	48	128	16		2	X	X	1000 Ksps	2	8	5	X	X	24	1	54		X		X			
CY8C4126LQS-S455	24	64	8		2	X	X	806 Ksps	2	8	5	X	X	24	-	54		X				X	
CY8C4146LQS-S245	48	64	8		-	-	-	1000 Ksps	2	8	5	X	X	24	-	54		X				X	
CY8C4146LQS-S255	48	64	8		-	-	X	1000 Ksps	2	8	5	X	X	24	-	54		X				X	
CY8C4146LQS-S265	48	64	8		-	X	-	1000 Ksps	2	8	5	X	X	24	-	54		X				X	
CY8C4146LQS-S275	48	64	8		-	X	X	1000 Ksps	2	8	5	X	X	24	-	54		X				X	
CY8C4146LQS-S455	48	64	8		2	X	X	1000 Ksps	2	8	5	X	X	24	-	54		X				X	
CY8C4127LQS-S445	24	128	16		2	-	X	806 Ksps	2	8	5	X	X	24	-	54		X				X	
CY8C4127LQS-S455	24	128	16		2	X	X	806 Ksps	2	8	5	X	X	24	-	54		X				X	
CY8C4147LQS-S245	48	128	16		-	-	-	1000 Ksps	2	8	5	X	X	24	-	54		X				X	
CY8C4147LQS-S255	48	128	16		-	-	X	1000 Ksps	2	8	5	X	X	24	-	54		X				X	
CY8C4147LQS-S265	48	128	16		-	X	-	1000 Ksps	2	8	5	X	X	24	-	54		X				X	
CY8C4147LQS-S275	48	128	16		-	X	X	1000 Ksps	2	8	5	X	X	24	-	54		X				X	
CY8C4147LQS-S285	48	128	16		-	-	X	1000 Ksps	2	8	5	X	X	24	1	54		X				X	
CY8C4147LQS-S295	48	128	16		-	X	X	1000 Ksps	2	8	5	X	X	24	1	54		X				X	
CY8C4147LQS-S445	48	128	16		2	-	X	1000 Ksps	2	8	5	X	X	24	-	54		X				X	
CY8C4147LQS-S455	48	128	16		2	X	X	1000 Ksps	2	8	5	X	X	24	-	54		X				X	
CY8C4147LQS-S465	48	128	16		2	-	X	1000 Ksps	2	8	5	X	X	24	1	54		X				X	
CY8C4147LQS-S475	48	128	16		2	X	X	1000 Ksps	2	8	5	X	X	24	1	54		X				X	
CY8C4126LQE-S455	24	64	8		2	X	X	806 Ksps	2	8	5	X	X	24	-	54		X					X
CY8C4146LQE-S245	48	64	8			-		1000 Ksps	2	8	5	X	X	24	-	54		X					X
CY8C4146LQE-S255	48	64	8			-	X	1000 Ksps	2	8	5	X	X	24	-	54		X					X
CY8C4146LQE-S265	48	64	8			X		1000 Ksps	2	8	5	X	X	24	-	54		X					X



Table 42 Ordering information (continued)

MPN	Features															Packages				Operating Temp			
	Max CPU Speed (MHz)	Flash (KB)	SRAM (KB)	UDB	Opamp (CTBm)	CAPSENSE™	Direct LCD Drive	12-bit SAR ADC	LP Comparators	TCPWM Blocks	SCB Blocks	WCO	ECO	Smart I/Os	CAN	GPIO	40-QFN	48-QFN	64-WQFN	64-TQFP	-40 to +85C	-40 to +105C	-40 to +125C
CY8C4146LQE-S275	48	64	8			X	X	1000 Ksps	2	8	5	X	X	24	-	54		X					X
CY8C4146LQE-S455	48	64	8		2	X	X	1000 Ksps	2	8	5	X	X	24	-	54		X					X
CY8C4127LQE-S445	24	128	16		2	-	X	806 Ksps	2	8	5	X	X	24	-	54		X					X
CY8C4127LQE-S455	24	128	16		2	X	X	806 Ksps	2	8	5	X	X	24	-	54		X					X
CY8C4147LQE-S245	48	128	16			-		1000 Ksps	2	8	5	X	X	24	-	54		X					X
CY8C4147LQE-S255	48	128	16			-	X	1000 Ksps	2	8	5	X	X	24	-	54		X					X
CY8C4147LQE-S265	48	128	16			X		1000 Ksps	2	8	5	X	X	24	-	54		X					X
CY8C4147LQE-S275	48	128	16			X	X	1000 Ksps	2	8	5	X	X	24	-	54		X					X
CY8C4147LQE-S285	48	128	16			-	X	1000 Ksps	2	8	5	X	X	24	1	54		X					X
CY8C4147LQE-S295	48	128	16			X	X	1000 Ksps	2	8	5	X	X	24	1	54		X					X
CY8C4147LQE-S445	48	128	16		2	-	X	1000 Ksps	2	8	5	X	X	24	-	54		X					X
CY8C4147LQE-S455	48	128	16		2	X	X	1000 Ksps	2	8	5	X	X	24	-	54		X					X
CY8C4147LQE-S465	48	128	16		2	-	X	1000 Ksps	2	8	5	X	X	24	1	54		X					X
CY8C4147LQE-S475	48	128	16		2	X	X	1000 Ksps	2	8	5	X	X	24	1	54		X					X
CY8C4126LQA-S453KA	24	64	8	-	2	X	X	806 Ksps	2	8	4	X	X	24	-	34	X				X		
CY8C4146LQA-S243KA	48	64	8	-	-	-	-	1000 Ksps	2	8	4	X	X	24	-	34	X				X		
CY8C4146LQA-S253KA	48	64	8	-	-	-	X	1000 Ksps	2	8	4	X	X	24	-	34	X				X		
CY8C4146LQA-S263KA	48	64	8	-	-	X	-	1000 Ksps	2	8	4	X	X	24	-	34	X				X		
CY8C4146LQA-S273KA	48	64	8	-	-	X	X	1000 Ksps	2	8	4	X	X	24	-	34	X				X		
CY8C4146LQA-S453KA	48	64	8	-	2	X	X	1000 Ksps	2	8	4	X	X	24	-	34	X				X		
CY8C4127LQA-S443KA	24	128	16	-	2	-	X	806 Ksps	2	8	4	X	X	24	-	34	X				X		
CY8C4127LQA-S453KA	24	128	16	-	2	X	X	806 Ksps	2	8	4	X	X	24	-	34	X				X		
CY8C4147LQA-S243KA	48	128	16	-	-	-	-	1000 Ksps	2	8	4	X	X	24	-	34	X				X		



Table 42 Ordering information (continued)

MPN	Features															Packages				Operating Temp			
	Max CPU Speed (MHz)	Flash (KB)	SRAM (KB)	UDB	Opamp (CTBm)	CAPSENSE™	Direct LCD Drive	12-bit SAR ADC	LP Comparators	TCPWM Blocks	SCB Blocks	WCO	ECO	Smart I/Os	CAN	GPIO	40-QFN	48-QFN	64-WQFN	64-TQFP	-40 to +85C	-40 to +105C	-40 to +125C
CY8C4147LQA-S253KA	48	128	16	-	-	-	X	1000 Ksps	2	8	4	X	X	24	-	34	X				X		
CY8C4147LQA-S263KA	48	128	16	-	-	X	-	1000 Ksps	2	8	4	X	X	24	-	34	X				X		
CY8C4147LQA-S273KA	48	128	16	-	-	X	X	1000 Ksps	2	8	4	X	X	24	-	34	X				X		
CY8C4147LQA-S283KA	48	128	16	-	-	-	X	1000 Ksps	2	8	4	X	X	24	1	34	X				X		
CY8C4147LQA-S293KA	48	128	16	-	-	X	X	1000 Ksps	2	8	4	X	X	24	1	34	X				X		
CY8C4147LQA-S443KA	48	128	16	-	2	-	X	1000 Ksps	2	8	4	X	X	24	-	34	X				X		
CY8C4147LQA-S453KA	48	128	16	-	2	X	X	1000 Ksps	2	8	4	X	X	24	-	34	X				X		
CY8C4147LQA-S463KA	48	128	16	-	2	-	X	1000 Ksps	2	8	4	X	X	24	1	34	X				X		
CY8C4147LQA-S473KA	48	128	16	-	2	X	X	1000 Ksps	2	8	4	X	X	24	1	34	X				X		
CY8C4126LQS-S453KA	24	64	8	-	2	X	X	806 Ksps	2	8	4	X	X	24	-	34	X					X	
CY8C4146LQS-S243KA	48	64	8	-	-	-	-	1000 Ksps	2	8	4	X	X	24	-	34	X					X	
CY8C4146LQS-S253KA	48	64	8	-	-	-	X	1000 Ksps	2	8	4	X	X	24	-	34	X					X	
CY8C4146LQS-S263KA	48	64	8	-	-	X	-	1000 Ksps	2	8	4	X	X	24	-	34	X					X	
CY8C4146LQS-S273KA	48	64	8	-	-	X	X	1000 Ksps	2	8	4	X	X	24	-	34	X					X	
CY8C4146LQS-S453KA	48	64	8	-	2	X	X	1000 Ksps	2	8	4	X	X	24	-	34	X					X	
CY8C4127LQS-S443KA	24	128	16	-	2	-	X	806 Ksps	2	8	4	X	X	24	-	34	X					X	
CY8C4127LQS-S453KA	24	128	16	-	2	X	X	806 Ksps	2	8	4	X	X	24	-	34	X					X	
CY8C4147LQS-S243KA	48	128	16	-	-	-	-	1000 Ksps	2	8	4	X	X	24	-	34	X					X	
CY8C4147LQS-S253KA	48	128	16	-	-	-	X	1000 Ksps	2	8	4	X	X	24	-	34	X					X	
CY8C4147LQS-S263KA	48	128	16	-	-	X	-	1000 Ksps	2	8	4	X	X	24	-	34	X					X	
CY8C4147LQS-S273KA	48	128	16	-	-	X	X	1000 Ksps	2	8	4	X	X	24	-	34	X					X	
CY8C4147LQS-S283KA	48	128	16	-	-	-	X	1000 Ksps	2	8	4	X	X	24	1	34	X					X	
CY8C4147LQS-S293KA	48	128	16	-	-	X	X	1000 Ksps	2	8	4	X	X	24	1	34	X					X	



Table 42 Ordering information (continued)

MPN	Features															Packages				Operating Temp				
	Max CPU Speed (MHz)	Flash (KB)	SRAM (KB)	UDB	Opamp (CTBm)	CAPSENSE™	Direct LCD Drive	12-bit SAR ADC	LP Comparators	TCPWM Blocks	SCB Blocks	WCO	ECO	Smart I/Os	CAN	GPIO	40-QFN	48-QFN	64-WQFN	64-TQFP	-40 to +85C	-40 to +105C	-40 to +125C	
CY8C4147LQS-S443KA	48	128	16	-	2	-	X	1000 Ksps	2	8	4	X	X	24	-	34	X					X		
CY8C4147LQS-S453KA	48	128	16	-	2	X	X	1000 Ksps	2	8	4	X	X	24	-	34	X					X		
CY8C4147LQS-S463KA	48	128	16	-	2	-	X	1000 Ksps	2	8	4	X	X	24	1	34	X					X		
CY8C4147LQS-S473KA	48	128	16	-	2	X	X	1000 Ksps	2	8	4	X	X	24	1	34	X					X		
CY8C4126LQE-S453KA	24	64	8	-	2	X	X	806 Ksps	2	8	4	X	X	24	-	34	X							X
CY8C4146LQE-S243KA	48	64	8	-	-	-	-	1000 Ksps	2	8	4	X	X	24	-	34	X							X
CY8C4146LQE-S253KA	48	64	8	-	-	-	X	1000 Ksps	2	8	4	X	X	24	-	34	X							X
CY8C4146LQE-S263KA	48	64	8	-	-	X	-	1000 Ksps	2	8	4	X	X	24	-	34	X							X
CY8C4146LQE-S273KA	48	64	8	-	-	X	X	1000 Ksps	2	8	4	X	X	24	-	34	X							X
CY8C4146LQE-S453KA	48	64	8	-	2	X	X	1000 Ksps	2	8	4	X	X	24	-	34	X							X
CY8C4127LQE-S443KA	24	128	16	-	2	-	X	806 Ksps	2	8	4	X	X	24	-	34	X							X
CY8C4127LQE-S453KA	24	128	16	-	2	X	X	806 Ksps	2	8	4	X	X	24	-	34	X							X
CY8C4147LQE-S243KA	48	128	16	-	-	-	-	1000 Ksps	2	8	4	X	X	24	-	34	X							X
CY8C4147LQE-S253KA	48	128	16	-	-	-	X	1000 Ksps	2	8	4	X	X	24	-	34	X							X
CY8C4147LQE-S263KA	48	128	16	-	-	X	-	1000 Ksps	2	8	4	X	X	24	-	34	X							X
CY8C4147LQE-S273KA	48	128	16	-	-	X	X	1000 Ksps	2	8	4	X	X	24	-	34	X							X
CY8C4147LQE-S283KA	48	128	16	-	-	-	X	1000 Ksps	2	8	4	X	X	24	1	34	X							X
CY8C4147LQE-S293KA	48	128	16	-	-	X	X	1000 Ksps	2	8	4	X	X	24	1	34	X							X
CY8C4147LQE-S443KA	48	128	16	-	2	-	X	1000 Ksps	2	8	4	X	X	24	-	34	X							X
CY8C4147LQE-S453KA	48	128	16	-	2	X	X	1000 Ksps	2	8	4	X	X	24	-	34	X							X
CY8C4147LQE-S463KA	48	128	16	-	2	-	X	1000 Ksps	2	8	4	X	X	24	1	34	X							X
CY8C4147LQE-S473KA	48	128	16	-	2	X	X	1000 Ksps	2	8	4	X	X	24	1	34	X							X

Ordering information

The nomenclature used in the preceding table is based on the following part numbering convention:

Field	Description	Values	Meaning
CY8C	Cypress Prefix		
4	Architecture	4	PSoC 4
A	Family	1	4100 Family
B	CPU Speed	2	24 MHz
		4	48 MHz
C	Flash Capacity	4	16 KB
		5	32 KB
		6	64 KB
		7	128 KB
DE	Package Code	AZ	TQFP (0.5-mm pitch)
		LQ	QFN
F	Temperature Range	A	Automotive (AEC-Q100: -40 °C to +85 °C)
		S	Automotive (AEC-Q100: -40 °C to +105 °C)
		E	Automotive (AEC-Q100: -40 °C to +125 °C)
S	Silicon Family	S	PSoC 4 S-Series
		M	PSoC 4 M-Series
		L	PSoC 4 L-Series
		BL	PSoC 4 BLE-Series
XYZ	Attributes Code	000-999	Code of feature set in the specific family

Ordering information

The following is an example of a part number:

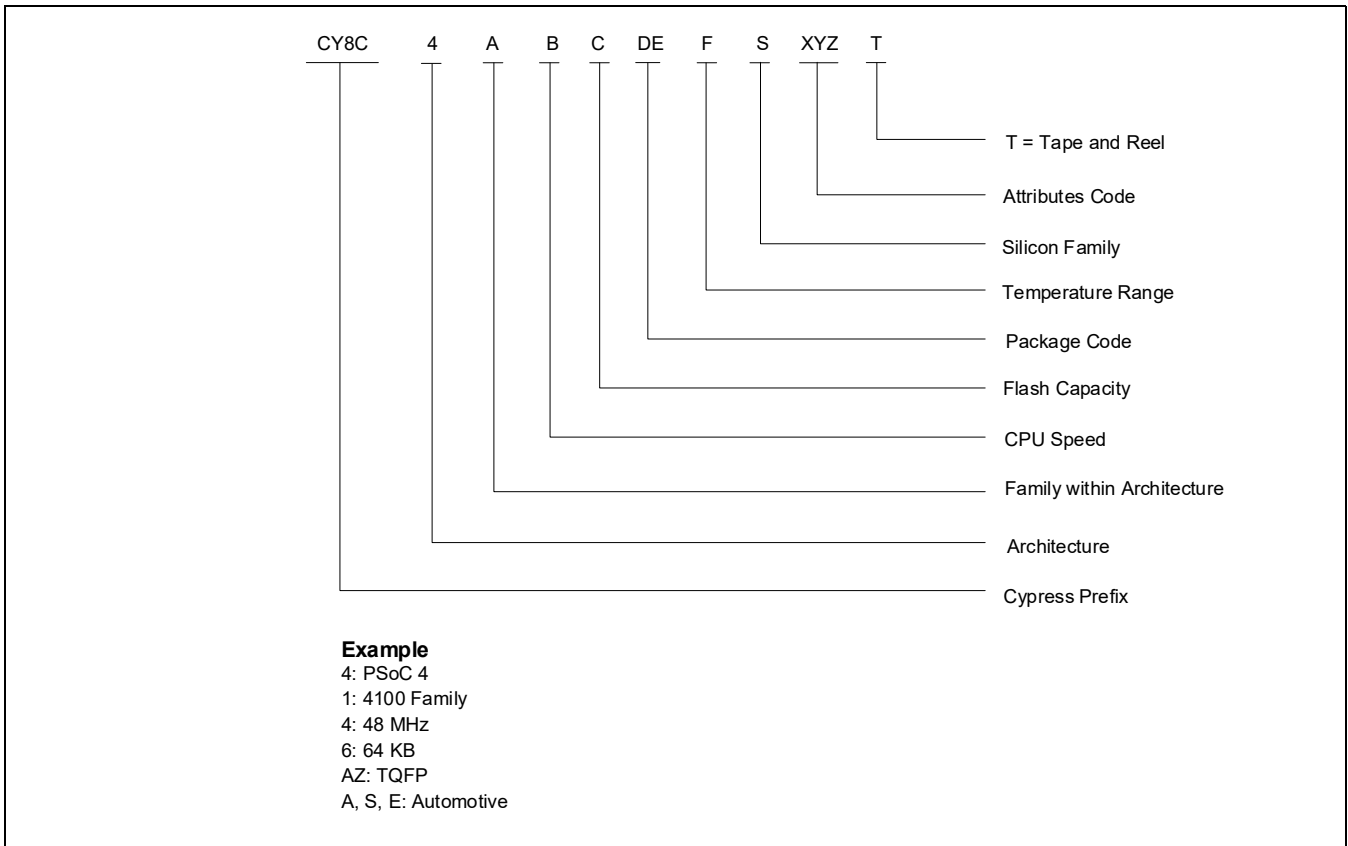

Packaging

10 Packaging

The PSoC 4100S Plus will be offered in 40-QFN, 48-QFN, 64-QFN, and 64-TQFP packages.

Table 43 provides the package dimensions and Cypress drawing numbers.

Table 43 Package List

Spec ID#	Package	Description	Package Dwg
BID27	64-pin TQFP	10 × 10 × 1.6-mm height with 0.5-mm pitch	51-85051
BID27A	40-pin QFN	6 × 6 × 0.6-mm height with 0.5-mm pitch with wettable flanks	002-25105
BID28	48-pin QFN	7.0X7.0X1.0 mm	002-29721
BID29	64-pin QFN	9.0X9.0X0.9 mm	002-31760

Table 44 Package thermal characteristics

Parameter	Description	Package	Conditions	Min	Typ	Max	Unit
T _A	Operating ambient temperature	–	For A-grade devices	–40	25	85	°C
			For S-grade devices	–40	25	105	
			For E-grade devices	–40	25	125	
T _J	Operating junction temperature	–	For A-grade devices	–40	–	100	
			For S-grade devices	–40	–	115	
			For E-grade devices	–40	–	140	
T _{JA}	Package θ_{JA}	64-pin TQFP	–	–	46	–	°C/Watt
		40-pin QFN		–	25	–	
		64-pin QFN			17		
T _{JC}	Package θ_{JC}	64-pin TQFP	–	–	10	–	°C/Watt
		40-pin QFN		–	3	–	
		64-pin QFN			6		

Table 45 Solder reflow peak temperature

Package	Maximum peak temperature	Maximum time at peak temperature
All	260 °C	30 seconds

Table 46 Package moisture sensitivity level (MSL), IPC/JEDEC J-STD-020

Package	MSL
All	MSL 3

10.1 Package diagrams

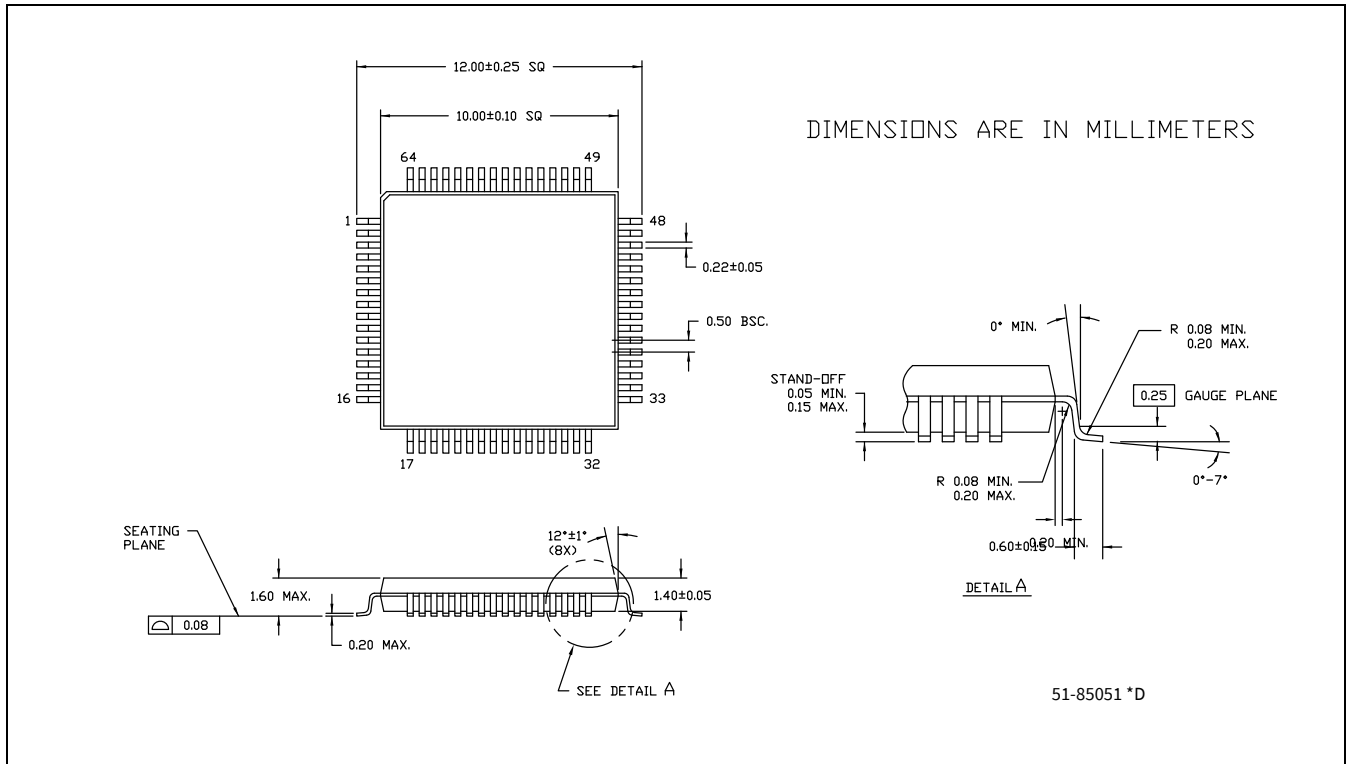

Figure 7 64-pin TQFP (10 × 10 × 1.4 mm) Package Outline, 51-85051

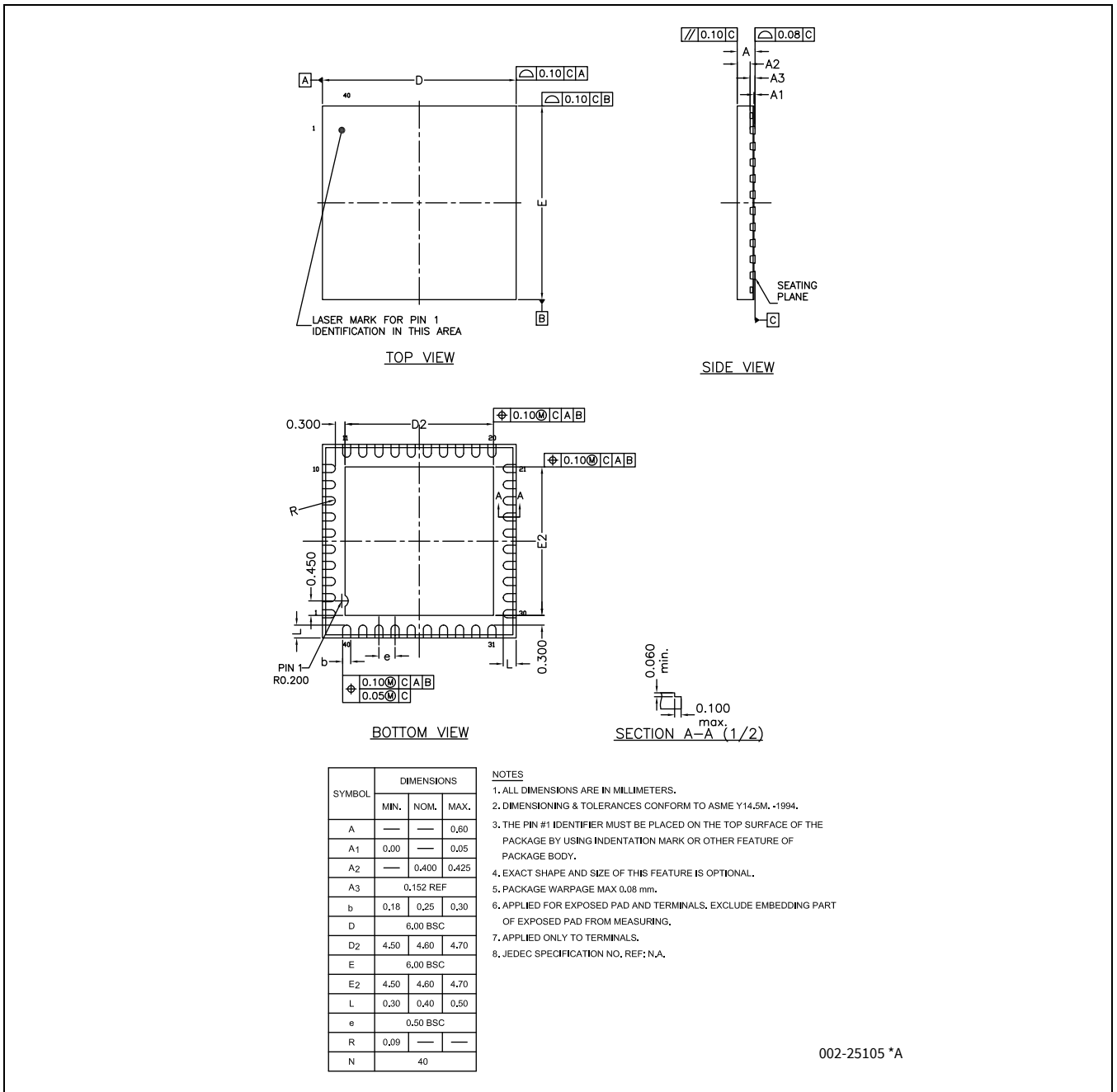

Figure 8 40-pin QFN (6 × 6 × 0.6 mm (4.6 × 4.6 mm E-Pad (Sawn))) Package Outline, 002-25105

Packaging

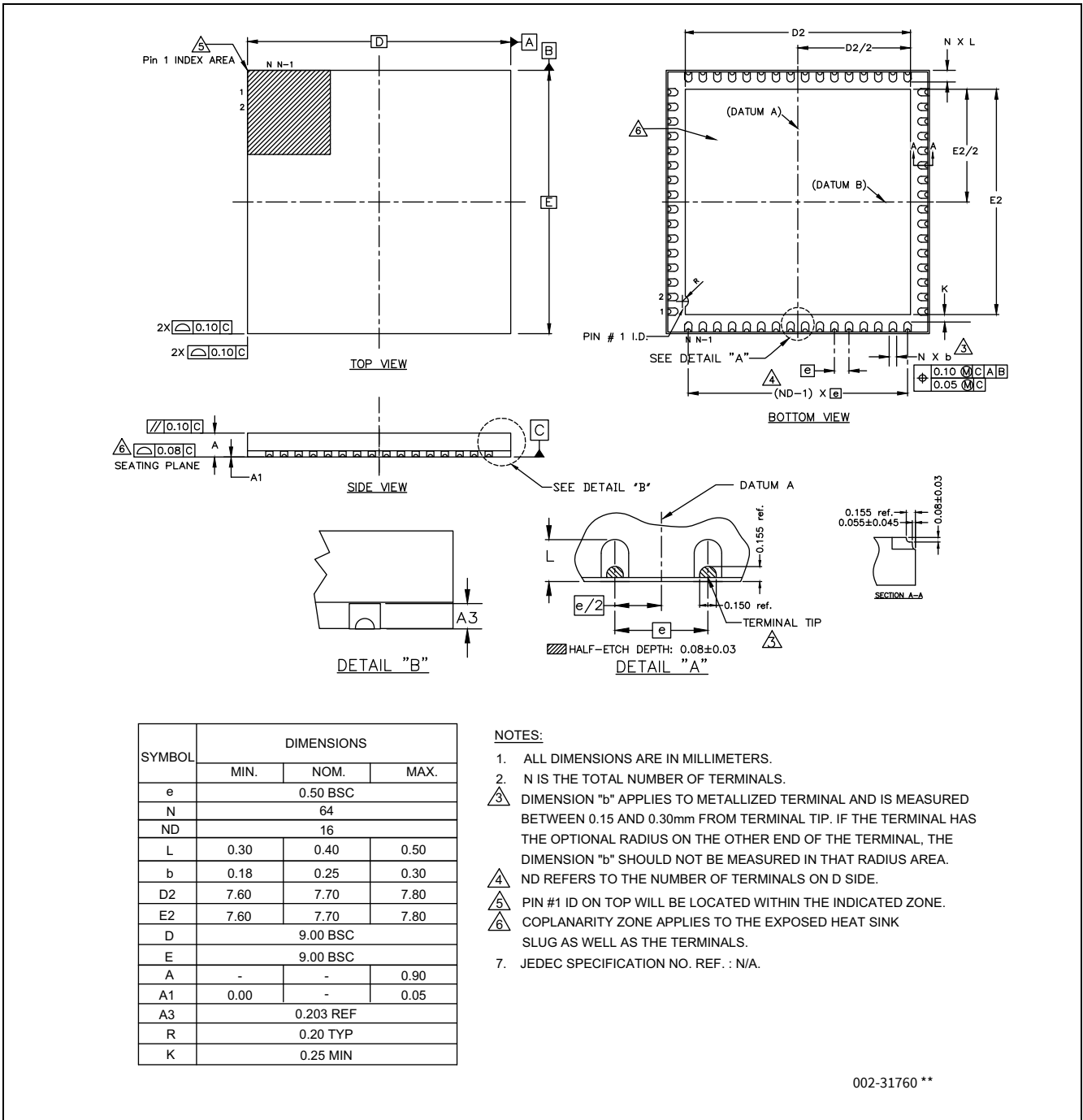

Figure 9 64-pin QFN (9 × 9 × 0.9 mm (7.70 × 7.70 mm E-Pad (Sawn))) Package Outline, 002-31760

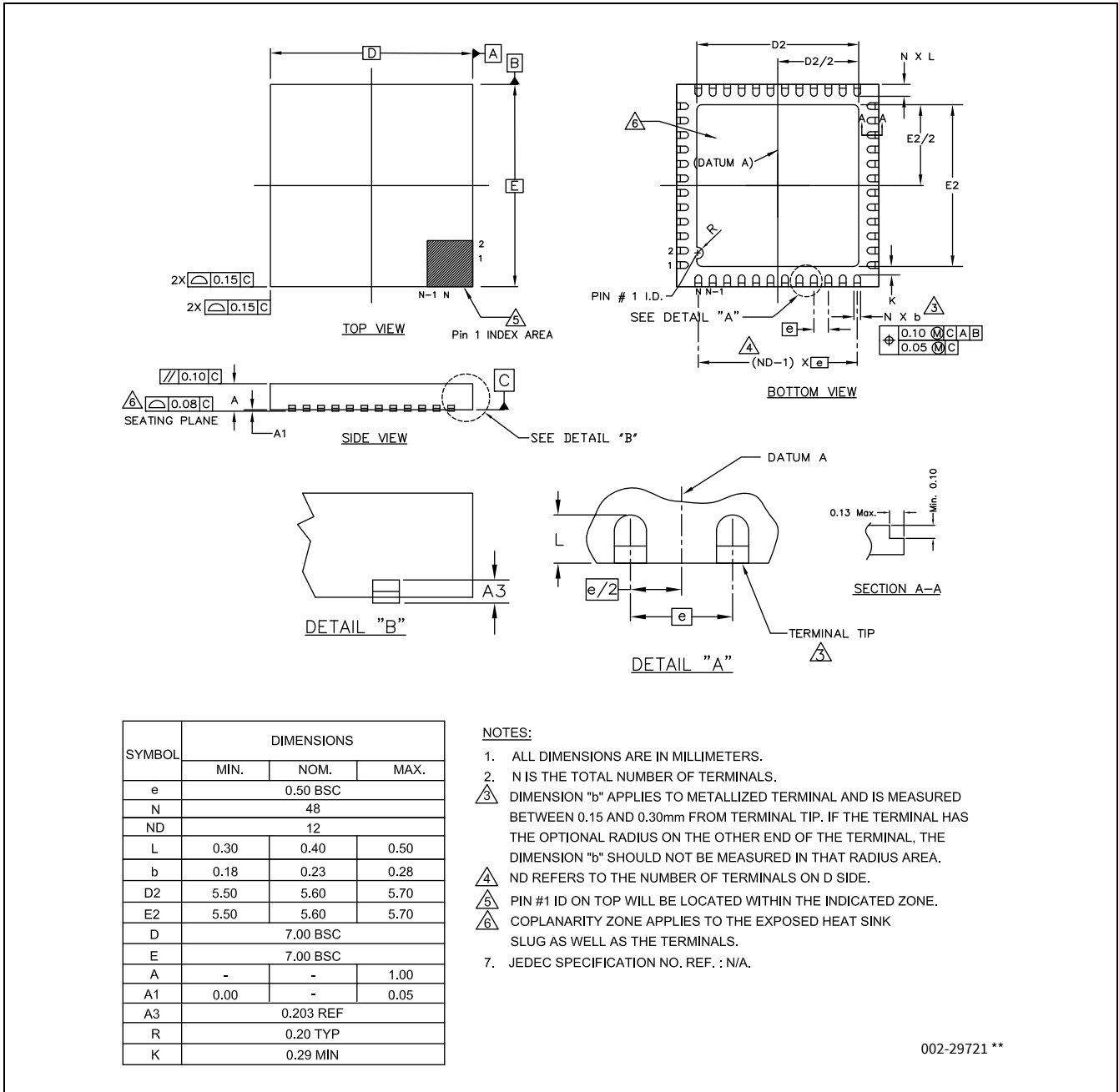

Figure 10 48-pin QFN (7 × 7 × 1.0 mm) wettable flank package)

11 Acronyms

Table 47 Acronyms used in this document

Acronym	Description
abus	analog local bus
ADC	analog-to-digital converter
AG	analog global
AHB	AMBA (advanced microcontroller bus architecture) high-performance bus, an ARM data transfer bus
ALU	arithmetic logic unit
AMUXBUS	analog multiplexer bus
API	application programming interface
APSR	application program status register
Arm®	advanced RISC machine, a CPU architecture
ATM	automatic thump mode
BW	bandwidth
CAN	Controller Area Network, a communications protocol
CMRR	common-mode rejection ratio
CPU	central processing unit
CRC	cyclic redundancy check, an error-checking protocol
DAC	digital-to-analog converter, see also IDAC, VDAC
DFB	digital filter block
DIO	digital input/output, GPIO with only digital capabilities, no analog. See GPIO.
DMIPS	Dhrystone million instructions per second
DMA	direct memory access, see also TD
DNL	differential nonlinearity, see also INL
DNU	do not use
DR	port write data registers
DSI	digital system interconnect
DWT	data watchpoint and trace
ECC	error correcting code
ECO	external crystal oscillator
EEPROM	electrically erasable programmable read-only memory
EMI	electromagnetic interference
EMIF	external memory interface
EOC	end of conversion
EOF	end of frame
EPSR	execution program status register
ESD	electrostatic discharge
ETM	embedded trace macrocell
FIR	finite impulse response, see also IIR
FPB	flash patch and breakpoint
FS	full-speed

Acronyms

Table 47 Acronyms used in this document *(continued)*

Acronym	Description
GPIO	general-purpose input/output, applies to a PSoC pin
HVI	high-voltage interrupt, see also LVI, LVD
IC	integrated circuit
IDAC	current DAC, see also DAC, VDAC
IDE	integrated development environment
I ² C, or IIC	Inter-Integrated Circuit, a communications protocol
IIR	infinite impulse response, see also FIR
ILO	internal low-speed oscillator, see also IMO
IMO	internal main oscillator, see also ILO
INL	integral nonlinearity, see also DNL
I/O	input/output, see also GPIO, DIO, SIO, USBIO
IPOR	initial power-on reset
IPSR	interrupt program status register
IRQ	interrupt request
ITM	instrumentation trace macrocell
LCD	liquid crystal display
LIN	Local Interconnect Network, a communications protocol.
LR	link register
LUT	lookup table
LVD	low-voltage detect, see also LVI
LVI	low-voltage interrupt, see also HVI
LVTTL	low-voltage transistor-transistor logic
MAC	multiply-accumulate
MCU	microcontroller unit
MISO	master-in slave-out
NC	no connect
NMI	nonmaskable interrupt
NRZ	non-return-to-zero
NVIC	nested vectored interrupt controller
NVL	nonvolatile latch, see also WOL
opamp	operational amplifier
PAL	programmable array logic, see also PLD
PC	program counter
PCB	printed circuit board
PGA	programmable gain amplifier
PHUB	peripheral hub
PHY	physical layer
PICU	port interrupt control unit
PLA	programmable logic array
PLD	programmable logic device, see also PAL

Acronyms

Table 47 Acronyms used in this document *(continued)*

Acronym	Description
PLL	phase-locked loop
PMDD	package material declaration data sheet
POR	power-on reset
PRES	precise power-on reset
PRS	pseudo random sequence
PS	port read data register
PSoC™	Programmable system-on-chip
PSRR	power supply rejection ratio
PWM	pulse-width modulator
RAM	random-access memory
RISC	reduced-instruction-set computing
RMS	root-mean-square
RTC	real-time clock
RTL	register transfer language
RTR	remote transmission request
RX	receive
SAR	successive approximation register
SC/CT	switched capacitor/continuous time
SCL	I ² C serial clock
SDA	I ² C serial data
S/H	sample and hold
SINAD	signal to noise and distortion ratio
SIO	special input/output, GPIO with advanced features. See GPIO.
SOC	start of conversion
SOF	start of frame
SPI	Serial Peripheral Interface, a communications protocol
SR	slew rate
SRAM	static random access memory
SRES	software reset
SWD	serial wire debug, a test protocol
SWV	single-wire viewer
TD	transaction descriptor, see also DMA
THD	total harmonic distortion
TIA	transimpedance amplifier
TRM	technical reference manual
TTL	transistor-transistor logic
TX	transmit
UART	Universal Asynchronous Transmitter Receiver, a communications protocol
UDB	universal digital block

Acronyms

Table 47 **Acronyms used in this document** *(continued)*

Acronym	Description
USB	Universal Serial Bus
USBIO	USB input/output, PSoC pins used to connect to a USB port
VDAC	voltage DAC, see also DAC, IDAC
WDT	watchdog timer
WOL	write once latch, see also NVL
WRES	watchdog timer reset
XRES	external reset I/O pin
XTAL	crystal

12 Document conventions

12.1 Units of measure

Table 48 Units of measure

Symbol	Unit of measure
°C	degrees Celsius
dB	decibel
fF	femto farad
Hz	hertz
KB	1024 bytes
kbps	kilobits per second
Khr	kilohour
kHz	kilohertz
kΩ	kilo ohm
ksps	kilosamples per second
LSB	least significant bit
Mbps	megabits per second
MHz	megahertz
MΩ	mega-ohm
Msps	megasamples per second
μA	microampere
μF	microfarad
μH	microhenry
μs	microsecond
μV	microvolt
μW	microwatt
mA	milliampere
ms	millisecond
mV	millivolt
nA	nanoampere
ns	nanosecond
nV	nanovolt
Ω	ohm
pF	picofarad
ppm	parts per million
ps	picosecond
s	second
sps	samples per second
sqrtHz	square root of hertz
V	volt

Revision history

Document version	Date of release	Description of changes
*G	2019-05-03	Changed status from Preliminary to Final.
*H	2019-06-21	Added 40-pin QFN package related information in all instances across the document. Updated Pinouts : Updated Table 1 . Updated Ordering information : Updated part numbers. Added Note “ Contact Cypress for the availability of 40-pin QFN package devices.” and referred the same note in description above table. Updated Packaging : Added spec 002-25105 *A. Updated to new template.
*I	2019-07-04	Updated Pinouts : Updated Table 1 (Fixed typo). Updated to new template.
*J	11/11/2019	Updated Electrical specifications : Updated Analog peripherals : Updated CTBm opamp : Updated Table 10 . Updated System resources : Updated Internal main oscillator : Updated Table 32 . Updated Ordering information : No changed in part numbers. Removed Note “ Contact Cypress for the availability of Grade-E devices.” and its reference. Removed Note “ Contact Cypress for the availability of 40-pin QFN package devices.” and its reference.
*K	06/26/2020	Updated Pinouts : Updated Alternate pin functions : Removed “Note that this is preliminary and subject to change.” in description below the heading. Updated Table 2 . Updated Electrical specifications : Updated Device-level specifications : Removed Note “Grade-E specifications (at +125 °C) are preliminary. Contact Cypress for the availability of Grade-E devices.” and its reference. Updated Table 4 . Updated Analog peripherals : Updated Temperature sensor : Updated Table 13 . Updated Digital peripherals : Updated Flash : Updated Table 27 . Updated System resources : Updated External crystal oscillator and PLL : Updated Table 38 . Updated Ordering information : No changed in part numbers. Added Note “ Contact Cypress for the availability of Grade-E devices.” and referred the same note in description above table.

Revision history

Document version	Date of release	Description of changes
*L	2021-03-30	Updated Functional definition : Updated Fixed function digital blocks : Updated Serial communication block (SCB) : Updated description. Updated Pinouts : Updated description of power pins below Table 1 . Updated Power : Updated description. Updated Electrical specifications : Updated Device-level specifications : Updated Table 4 . Updated System resources : Updated Power-on reset (POR) : Updated Table 28 . Refer to Product Information Notice #6965423.
*M	2021-07-02	Added 64-pin QFN package related information in all instances across the document. Updated Pinouts : Updated Table 1 . Updated Ordering information : Updated part numbers. Added * at the end of newly added MPNs. Added “* Indicates New MPNs.” at the end of table. Updated Packaging : Added spec 002-31760 **. Updated to new template. Completing Sunset Review.
*N	2021-12-10	Updated Pinouts . Updated Ordering information and Packaging . Added footnote for SID.CLK#6. Converted to Infineon template.

Trademarks

All referenced product or service names and trademarks are the property of their respective owners.

Edition 2021-12-10
Published by
Infineon Technologies AG
81726 Munich, Germany

© 2021 Infineon Technologies AG.
All Rights Reserved.

Do you have a question about this document?
Go to www.cypress.com/support

Document reference
002-20072 Rev. *N

IMPORTANT NOTICE

The information given in this document shall in no event be regarded as a guarantee of conditions or characteristics ("Beschaffenhheitsgarantie").

With respect to any examples, hints or any typical values stated herein and/or any information regarding the application of the product, Infineon Technologies hereby disclaims any and all warranties and liabilities of any kind, including without limitation warranties of non-infringement of intellectual property rights of any third party.

In addition, any information given in this document is subject to customer's compliance with its obligations stated in this document and any applicable legal requirements, norms and standards concerning customer's products and any use of the product of Infineon Technologies in customer's applications.

The data contained in this document is exclusively intended for technically trained staff. It is the responsibility of customer's technical departments to evaluate the suitability of the product for the intended application and the completeness of the product information given in this document with respect to such application.

For further information on the product, technology, delivery terms and conditions and prices please contact your nearest Infineon Technologies office (www.infineon.com).

WARNINGS

Due to technical requirements products may contain dangerous substances. For information on the types in question please contact your nearest Infineon Technologies office.

Except as otherwise explicitly approved by Infineon Technologies in a written document signed by authorized representatives of Infineon Technologies, Infineon Technologies' products may not be used in any applications where a failure of the product or any consequences of the use thereof can reasonably be expected to result in personal injury.