

### 5 GHz DIVIDE-BY-2 STATIC PRESCALER

#### DESCRIPTION

The  $\mu$ PG501B is a divide-by-4 prescaler capable of operating up to 5 GHz.

It is intended to be used in the frequency synthesizers of microwave application systems and measurement equipment.

It is housed in a hermetic 8 pin ceramic flat package that is easy to install and realize high reliability.

#### FEATURES

- Wide operating frequency range;  $f_{in} = 1.5$  to 5.0 GHz
- Single Supply Voltage :  $V_{DD} = +10$  V
- Hermetically sealed package assures high reliability

#### ORDERING INFORMATION

| PART NUMBER  | PACKAGE             |
|--------------|---------------------|
| $\mu$ PG501B | K-12, 8 PIN CERAMIC |

#### ABSOLUTE MAXIMUM RATINGS ( $T_A = 25$ °C)

|                                  |           |                   |     |
|----------------------------------|-----------|-------------------|-----|
| Supply Voltage                   | $V_{DD}$  | +12               | V   |
| Supply Current                   | $I_{DD}$  | 150               | mA  |
| Total Power Dissipation          | $P_{tot}$ | 1.5 <sup>*1</sup> | W   |
| Input Power                      | $P_{in}$  | +20               | dBm |
| Operating Case Temperature Range | $T_C$     | -65 to +125       | °C  |
| Storage Temperature              | $T_{stg}$ | -65 to +175       | °C  |

\*1  $T_C \leq 125$  °C

#### RECOMMENDED OPERATING CONDITIONS ( $T_A = 25$ °C)

|                |          |      |   |
|----------------|----------|------|---|
| Supply Voltage | $V_{DD}$ | 10±1 | V |
|----------------|----------|------|---|

**ELECTRICAL CHARACTERISTICS (T<sub>A</sub> = -25 to +75 °C, V<sub>DD</sub> = +10 V, V<sub>GG</sub> = OPEN)**

| CHARACTERISTIC                 | SYMBOL             | MIN. | TYP. | MAX. | UNIT | TEST CONDITIONS                  |
|--------------------------------|--------------------|------|------|------|------|----------------------------------|
| Supply Current                 | I <sub>DD</sub>    | 50   | 70   | 90   | mA   |                                  |
| Upper Limit of Input Frequency | f <sub>in(u)</sub> | 5.0  | 5.3  |      | GHz  | P <sub>in</sub> = +10 dBm        |
| Lower Limit of Input Frequency | f <sub>in(l)</sub> |      | 0.7  | 1.3  | GHz  |                                  |
| Input Power                    | P <sub>in</sub>    | +10  |      |      | dBm  | f <sub>in</sub> = 1.5 to 5 GHz   |
|                                |                    | +6   |      | +10  |      | f <sub>in</sub> = 1.5 to 4.5 GHz |
| Output Power                   | P <sub>out</sub>   | -1   | +2   |      | dBm  | f <sub>in</sub> = 5 GHz          |

TYPICAL CHARACTERISTICS

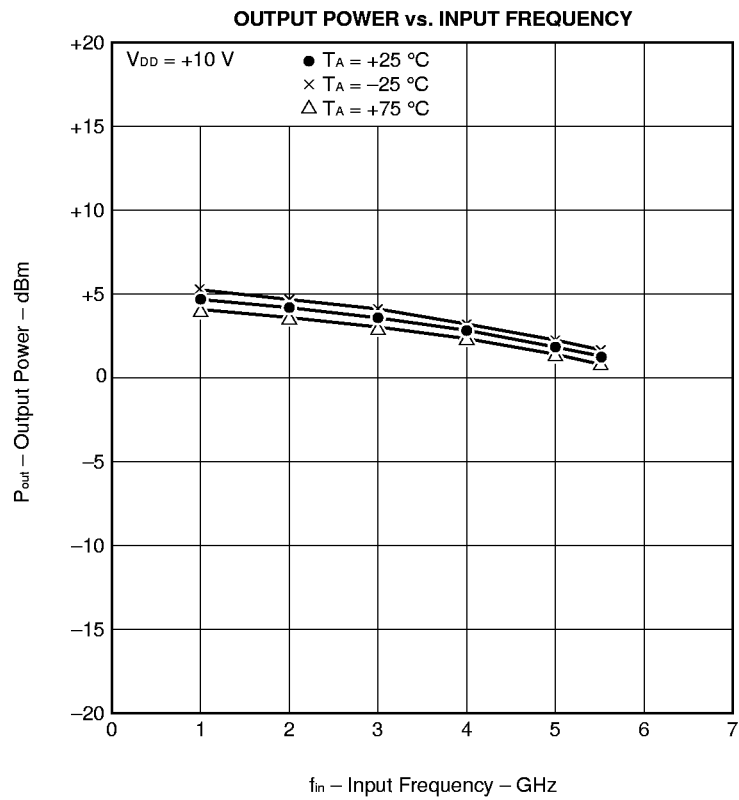
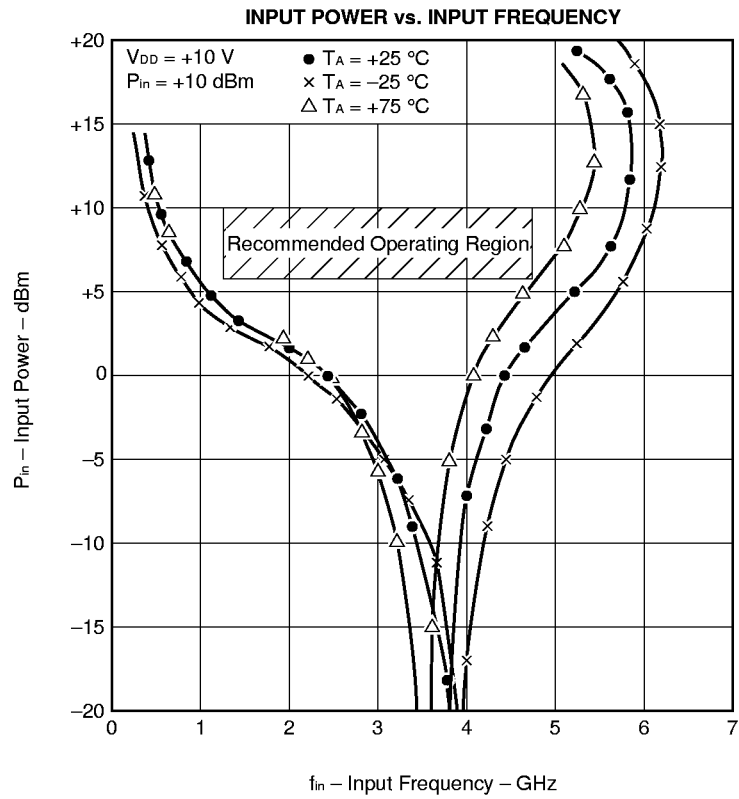

TEST CIRCUIT

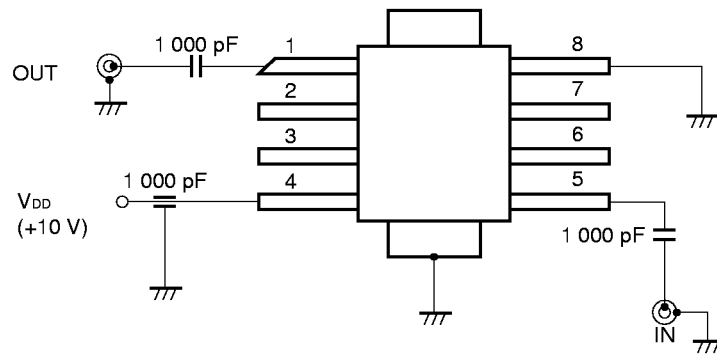

TEST CIRCUIT BLOCK DIAGRAM

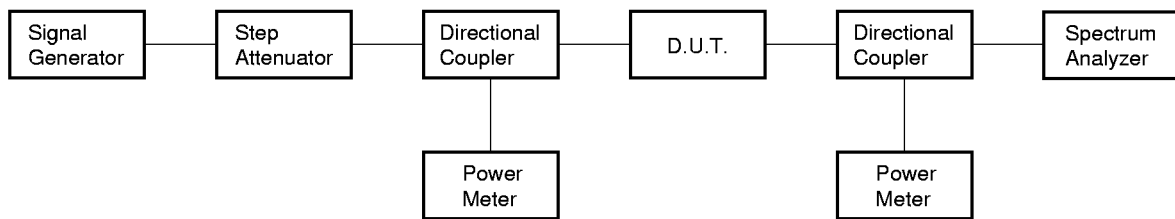

TEST JIG DRAWING

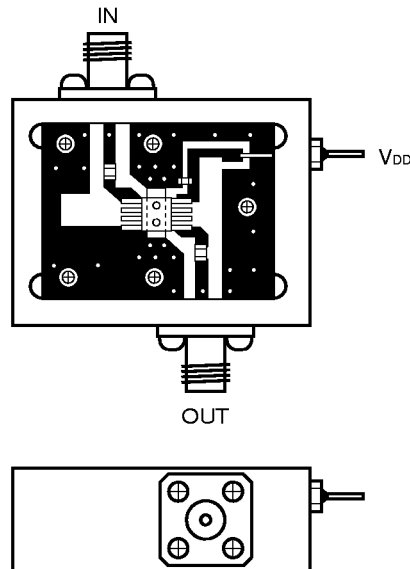

PACKAGE DIMENSIONS (Unit: mm)

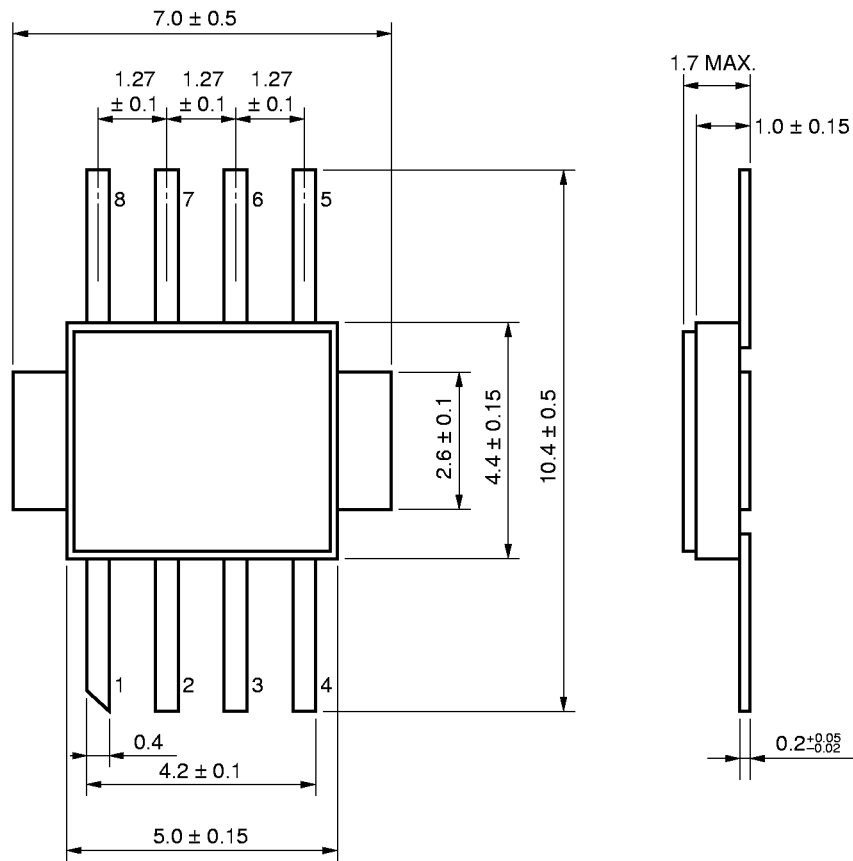

**PIN CONNECTIONS**

1: OUTPUT

2: NC\*

3: NC\*

4: V<sub>DD</sub>

5: INPUT

6: V<sub>GG</sub>

7: NC\*

8: GND

FLANGE: GND

\*: Non Connection

**RECOMMENDED SOLDERING CONDITIONS**

The following conditions (see table below) must be met when soldering this product.

Please consult with our sales offices in case other soldering process is used, or in case soldering is done under different conditions.

**TYPES OF SURFACE MOUNT DEVICE**

For more details, refer to our document “SEMICONDUCTOR DEVICE MOUNTING TECHNOLOGY MANUAL” (C10535E).

| Soldering process      | Soldering conditions   | Symbol |
|------------------------|--|--------|
| Partial heating method | Terminal temperature: 260 °C or below,<br>Flow time: 10 seconds or below,<br>Exposure limit*: None |        |

\* Exposure limit before soldering after dry-pack package is opened.  
Storage conditions: 25 °C and relative humidity at 65 % or less.

**Note** Do not apply more than a single process at once, except for “Partial heating method”.

**PRECAUTION** This IC must be handled with great care to prevent static discharge because its circuitry is composed of GaAs MES FET.

**Caution**

**The Great Care must be taken in dealing with the devices in this guide.  
The reason is that the material of the devices is GaAs (Gallium Arsenide), which is designated as harmful substance according to the law concerned.  
Keep the law concerned and so on, especially in case of removal.**