

FEATURES

- CLASS A OPERATION
- HIGH EFFICIENCY: $\eta_{ADD} \geq 35\%$ TYP
- BROADBAND CAPABILITY
- AVAILABILITY:
 - Chip
 - Hermetic Package
- PARTIALLY MATCHED INPUT FOR PACKAGED DEVICES
- PROVEN RELIABILITY

DESCRIPTION

The NE800495 power GaAs FET covers the 3.5 to 8.5 GHz frequency range with five different Class A, 2 W partially matched devices. Each packaged device has an input lumped element matching network.

The NE800400 is the four-cell recessed gate chip used in "95" package. Recommended bias is 8 to 9 volts for CW operations and up to 13 volts for pulsed operation.

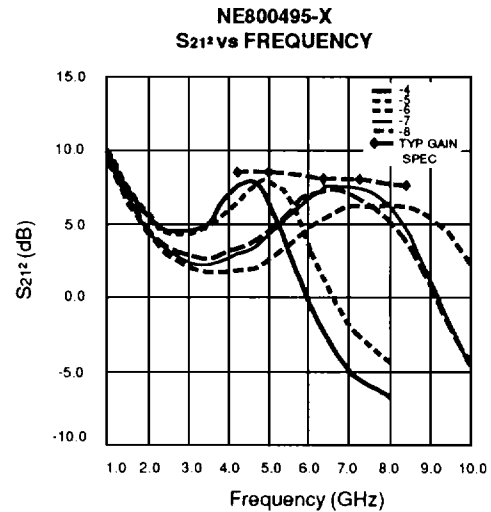

ELECTRICAL CHARACTERISTICS (T_A = 25°C)

PART NUMBER PACKAGE OUTLINE			NE800400 ¹ 00 (CHIP)			NE800495-4,5 95			NE800495-6,7 95			NE800495-8 95		
SYMBOLS	PARAMETERS AND CONDITIONS	UNITS	MIN	TYP	MAX	MIN	TYP	MAX	MIN	TYP	MAX	MIN	TYP	MAX
I _{DSS}	Saturated Drain Current at V _{DS} = 2.5 V, V _{GS} = 0	A	0.9	1.2	1.6	0.9	1.2	1.6	0.9	1.2	1.6	0.9	1.2	1.6
V _P	Pinch-off Voltage at V _{DS} = 2.5 V, I _D = 8 mA	V	-5	-3.5	-2.5	-5	-3.5	-2.5	-5	-3.5	-2.5	-5	-3.5	-2.5
g _m	Transconductance at V _{DS} = 3 V, I _D = 0.4 A	mS		240			240			240			240	
R _{TH}	Thermal Resistance (Channel-to-Case)	°C/W						15	16				15	16
P _T	Total Power Dissipation	W			10			10			10			10
P _{TEST} ²	Power Output at Test Point P _{IN} = 25 dBm, V _{DS} = 9 V, I _D ≤ 600 mA P _{IN} = 26 dBm, V _{DS} = 9 V, I _D ≤ 600 mA P _{IN} = 26.5 dBm, V _{DS} = 9 V, I _D ≤ 600 mA	dBm dBm dBm	32	33		32	33			32	33		32	33
P _{1dB} ³	Output Power at 1 dB Compression Point, V _{DS} = 9 V, I _D ≤ 600 mA	dBm		33			33			33			32.5	
G _{1dB} ³	Gain at 1 dB Compression Point V _{DS} = 9 V, I _D ≤ 600 mA	dB		7			7.5			7			6.5	
η _{ADD} ⁴	Power Added Efficiency V _{DS} = 8 V, I _D ≤ 600 mA, P _{OUT} = P _{1dB}	%		37			40			37			35	

Notes:

1. Four-cell chip: all cells are used. RF performance of the chip is determined by packaging 10 chips per wafer. Wafer rejection criteria for standard devices are 2 rejects per 10 samples.
2. This is a production test. Devices are measured in a broadband amplifier circuit with the drain current between 400 to 700 mA. The gate current is limited to 10 mA max. Test frequencies are: -4 @ 4.2 GHz, -5 @ 5 GHz, -6 @ 6.5 GHz, -7 @ 7.2 GHz, -8 @ 8.4 GHz.
3. Amplifier performance in a circuit optimized at the test frequency.
4. $\eta_{ADD} = \frac{P_{OUT} - P_{IN}}{V_{DS} \times I_D} \times 100\%$

NE8004 SERIES

ABSOLUTE MAXIMUM RATINGS (TA = 25°C)

SYMBOLS	PARAMETERS	UNITS	RATINGS
V _{DS}	Drain to Source Voltage	V	20
V _{GS}	Gate to Source Voltage	V	-14
I _D	Drain Current	A	1.6
I _G	Gate Current	mA	10
T _{CH}	Channel Temperature	°C	175
T _{STG}	Storage Temperature	°C	-65 to +175

SELECTION CHART

PART NUMBER	TYPICAL PERFORMANCE		
	P _{1dB} (WATTS)	FREQUENCY RANGE (GHz)	G _{1dB} (dB)
NE800400	2	2 to 10	7
NE800495-4	2	3.5 to 4.5	7.5
NE800495-5	2	4.5 to 5.5	7.5
NE800495-6	2	5.5 to 6.5	7
NE800495-7	2	6.5 to 7.5	7
NE800495-8	1.8	7.5 to 8.5	6.5

OUTLINE DIMENSIONS AND HANDLING

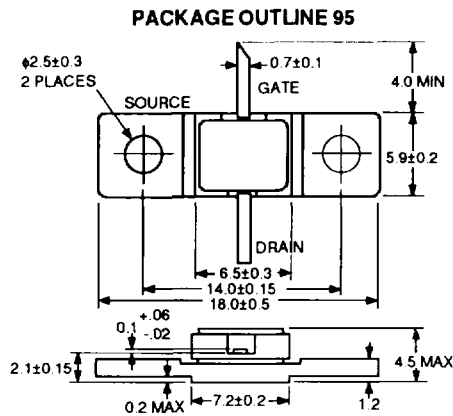

TYPICAL PERFORMANCE CURVE

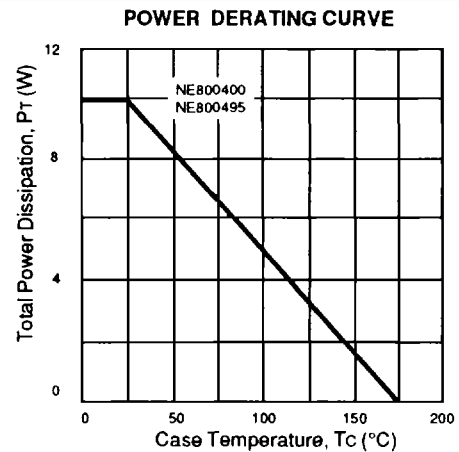

NE800400 (CHIP)

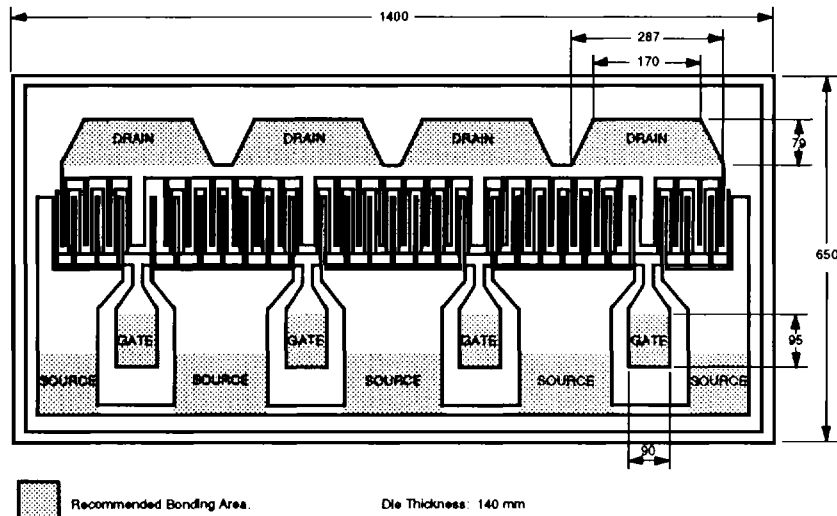

DIE ATTACHMENT

Die attach can be accomplished with either Au-Ge (390±10°C) or Au-Sn (290 ± 10°C) preforms in a forming gas environment. Epoxy die attach is not recommended.

BONDING

Gate and drain bonding wires should be minimum length, semi-hard fold wire (3-8% elongation) 30 microns or less in diameter. The source should be connected with gold ribbon or mesh.

Bonding should be performed with a wedge tip that has a taper of approximately 15°. Die attach and bonding time should be kept to a minimum. As a general rule, the bonding operation should be kept within a 300°C - 10 minute curve. If longer periods are required, the temperature should be lowered.

PRECAUTIONS

The user must operate in a clean, dry environment. The chip channel is glassivated for mechanical protection only and does not preclude the necessity of a clean environment.

The bonding equipment should be periodically checked for sources of surge voltage and should be properly grounded at all times. All test and handling equipment should be grounded to minimize the possibilities of static discharge.

See AN-1001 Recommended Handling Procedure for Microwave Transistor & MMIC Chips for additional information.

RF TEST CIRCUIT

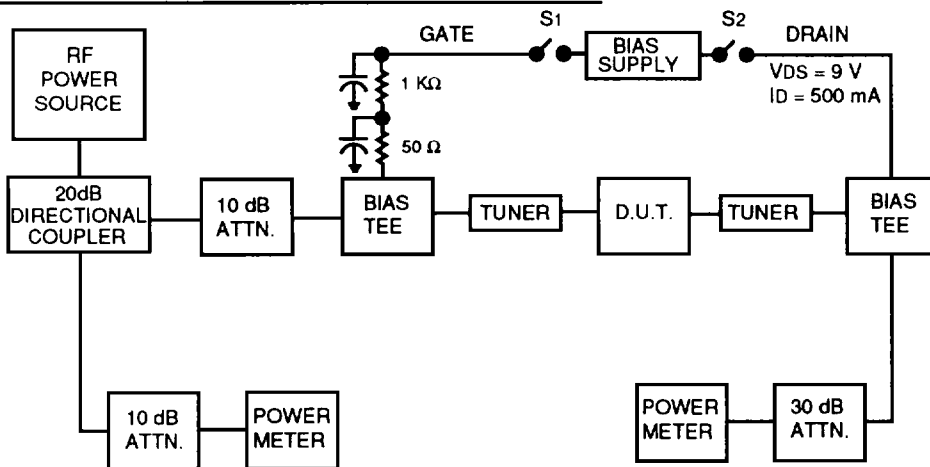

BIASING PROCEDURE

The proper bias sequence is to completely deplete the channel prior to application of the drain voltage. Next, decrease the gate voltage to obtain the required drain current. This bias sequence will prevent GUNN domains from forming in Power GaAs FETs. Turn on the power supply. Make sure its voltage is 0 V. Turn on S1 and S2. Apply $V_{GS} = -5$, then apply $V_{DS} = 9$ V. Decrease V_{GS} to obtain the required drain current, I_D . Apply the RF input and adjust the gate voltage to maintain the desired drain current. Do not exceed a gate current of 10 mA ($I_G = 10$ mA max).



TYPICAL SMALL SIGNAL COMMON SOURCE SCATTERING PARAMETERS

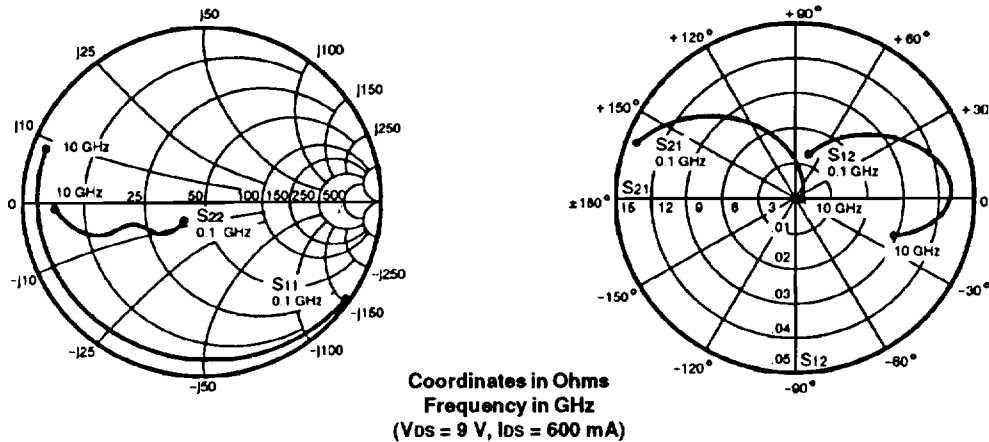

NE800400¹

$V_{DS} = 9$ V, $I_{DS} = 600$ mA

FREQUENCY (GHz)	S ₁₁		S ₂₁		S ₁₂		S ₂₂		K	MAG (dB) ²
	MAG	ANG	MAG	ANG	MAG	ANG	MAG	ANG		
.10	.99	-35	14.05	161	.014	69	.14	-125	.04	30.05
.20	.97	-64	12.20	145	.025	56	.23	-133	.07	26.96
.50	.94	-115	7.66	115	.037	30	.37	-150	.09	23.13
1.0	.93	-147	4.35	94	.043	11	.42	-160	.16	20.04
1.5	.92	-159	2.96	81	.044	3	.44	-161	.24	18.32
2.0	.92	-166	2.25	71	.043	-4	.46	-161	.32	17.19
2.5	.93	-171	1.83	63	.042	-7	.48	-160	.36	16.44
3.0	.92	-175	1.59	56	.041	-10	.50	-160	.49	15.87
3.5	.92	-177	1.28	48	.040	-13	.54	-160	.62	15.03
4.0	.92	-180	1.11	41	.039	-15	.56	-160	.74	14.52
4.5	.92	178	.94	35	.038	-18	.59	-161	.89	13.98
5.0	.92	176	.86	28	.036	-20	.62	-162	1.03	12.74
5.5	.92	174	.78	22	.033	-20	.64	-163	1.27	10.63
6.0	.92	172	.73	16	.034	-17	.66	-165	1.25	10.28
6.5	.92	171	.66	12	.034	-16	.68	-166	1.32	9.48
7.0	.92	170	.60	6	.037	-23	.70	-167	1.21	9.39
7.5	.92	168	.55	0	.033	-26	.72	-169	1.39	8.48
8.0	.93	167	.51	-5	.031	-25	.74	-171	1.43	8.22
8.5	.93	165	.47	-9	.029	-24	.76	-172	1.58	7.57
9.0	.93	164	.43	-15	.029	-22	.77	-174	1.63	7.09
9.5	.93	163	.41	-20	.029	-21	.78	-176	1.58	7.07
10.0	.93	161	.39	-23	.030	-21	.80	-177	1.50	7.01

Note:

1. S-Parameters include bond wires.

GATE: Total 4 wire (s), 1 per bond pad, 0.0278" (705 μm) long each wire.

DRAIN: Total 4 wire (s), 1 per bond pad, 0.0213" (540 μm) long each wire.

SOURCE: Total 15 wire (s), 3 per source area, 0.0063" (161 μm) long each wire.

WIRE: 0.0007" (17.8 μm) dia., gold.

2. Gain Calculations:

$$MAG = \frac{|S_{21}|}{|S_{12}|} (K \pm \sqrt{K^2 - 1})$$

When $K \leq 1$, MAG is undefined and MSG values are used. $MSG = \frac{|S_{21}|}{|S_{12}|}$, $K = \frac{1 + |\Delta|^2 - |S_{11}|^2 - |S_{22}|^2}{2 |S_{12} S_{21}|}$, $\Delta = S_{11} S_{22} - S_{21} S_{12}$

NE8004 SERIES

TYPICAL SMALL SIGNAL COMMON SOURCE SCATTERING PARAMETERS

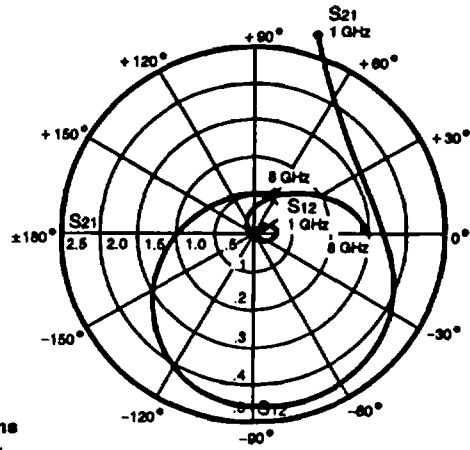
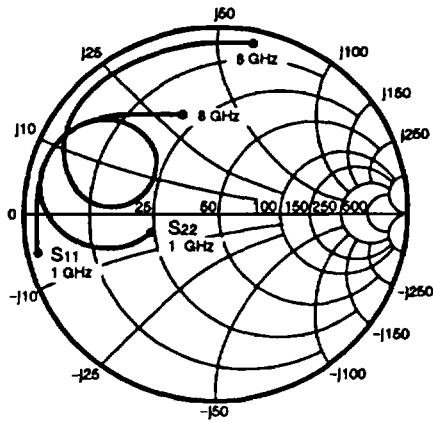

Coordinates in Ohms
Frequency in GHz
(V_{DS} = 9 V, I_{DS} = 600 mA)

NE800495-4

V_{DS} = 9 V, I_{DS} = 600 mA

FREQUENCY (GHz)	S ₁₁		S ₂₁		S ₁₂		S ₂₂		K	MAG (dB) ¹
	MAG	ANG	MAG	ANG	MAG	ANG	MAG	ANG		
.10	.99	-59	14.31	147	.009	65	.19	-146	.08	32.2
.20	.96	-98	10.72	126	.017	46	.25	-151	.16	28.0
.50	.93	-144	5.43	98	.025	28	.31	-161	.42	23.4
1.0	.94	-167	3.03	77	.028	26	.34	-164	.55	20.3
1.5	.94	-180	2.24	60	.031	27	.36	-162	.66	18.6
2.0	.92	172	1.86	45	.036	29	.41	-163	.88	17.1
2.5	.89	164	1.66	32	.041	28	.43	-164	1.08	14.4
3.0	.84	156	1.70	16	.048	26	.47	-161	1.16	13.0
3.2	.83	153	1.71	10	.050	24	.49	-160	1.15	13.0
3.4	.79	149	1.75	1	.053	18	.52	-160	1.16	12.8
3.6	.73	146	1.80	-7	.055	13	.55	-159	1.36	11.6
3.8	.71	144	2.08	-16	.056	7	.59	-159	1.02	14.9
4.0	.64	140	2.23	-27	.054	-1	.65	-160	1.04	14.8
4.2	.54	139	2.36	-42	.050	-14	.73	-162	1.16	14.4
4.4	.44	145	2.48	-60	.039	-32	.81	-167	1.34	14.5
4.6	.41	162	2.51	-79	.022	-58	.89	-174	1.83	15.3
4.8	.50	175	2.37	-97	.002	-147	.93	177	8.95	17.5
5.0	.64	176	2.08	-116	.025	132	.93	169	.34	19.2
5.5	.84	161	1.42	-153	.045	88	.82	154	.14	15.0
6.0	.92	146	.95	178	.080	67	.73	145	.04	10.7
6.5	.96	130	.70	151	.144	49	.66	138	.05	6.9
7.0	.95	114	.56	128	.176	38	.61	131	.26	5.0
7.5	.92	95	.50	101	.215	24	.57	123	.59	3.7
8.0	.93	73	.46	73	.257	8	.52	113	.60	2.6

Note:

1. Gain Calculations:

$$MAG = \frac{|S_{21}|}{|S_{12}|} (K \pm \sqrt{K^2 - 1})$$

When $K \leq 1$, MAG is undefined and MSG values are used. $MSG = \frac{|S_{21}|}{|S_{12}|}$, $K = \frac{1 + |\Delta|^2 - |S_{11}|^2 - |S_{22}|^2}{2 |S_{12} S_{21}|}$, $\Delta = S_{11} S_{22} - S_{21} S_{12}$

MAG = Maximum Available Gain

MSG = Maximum Stable Gain

TYPICAL SMALL SIGNAL COMMON SOURCE SCATTERING PARAMETERS

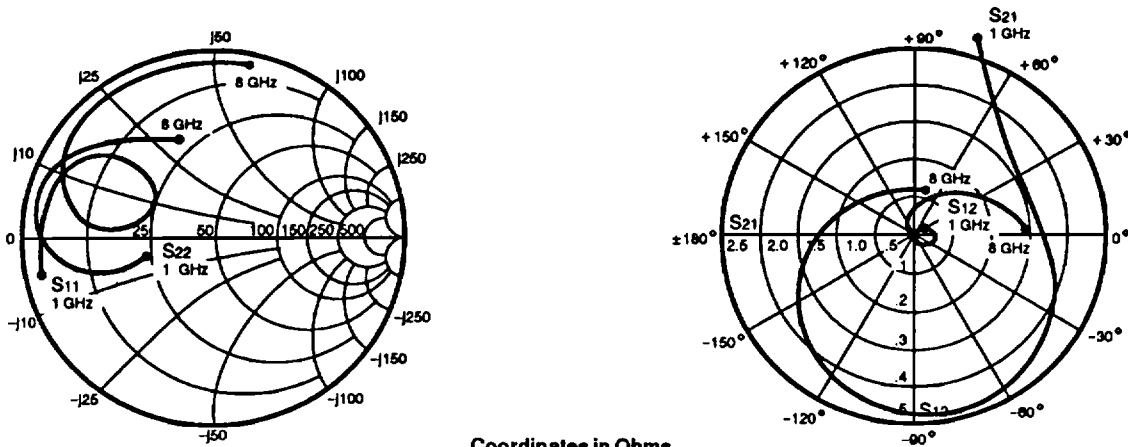

Coordinates in Ohms
Frequency in GHz
(V_{DS} = 9 V, I_{DS} = 600 mA)



NE800495-5

V_{DS} = 9 V, I_{DS} = 600 mA

FREQUENCY (GHz)	S ₁₁		S ₂₁		S ₁₂		S ₂₂		K	MAG (dB) ¹
	MAG	ANG	MAG	ANG	MAG	ANG	MAG	ANG		
0.1	.98	-58	15.06	148	.008	63	.16	-139	.08	32.6
0.2	.97	-97	11.35	127	.016	48	.23	-146	.15	28.5
0.5	.93	-143	5.75	98	.025	29	.29	-159	.41	23.7
1.0	.94	-166	3.19	76	.028	28	.32	-162	.58	20.5
1.5	.93	-179	2.33	60	.031	29	.34	-161	.71	18.7
2.0	.92	172	1.91	46	.036	33	.39	-163	.88	17.2
2.5	.89	165	1.67	32	.042	32	.42	-164	1.09	14.2
3.0	.86	157	1.63	17	.050	32	.44	-161	1.07	13.5
3.5	.83	150	1.70	2	.059	26	.49	-161	.95	14.6
4.0	.74	141	1.95	-17	.066	16	.56	-161	.88	14.7
4.2	.68	137	2.04	-27	.065	10	.61	-161	.94	14.9
4.4	.60	134	2.18	-40	.065	0	.67	-162	.95	15.3
4.6	.51	133	2.35	-53	.060	-8	.74	-165	.95	15.9
4.8	.41	139	2.48	-68	.050	-20	.81	-170	1.02	16.1
5.0	.37	156	2.48	-84	.031	-31	.89	-177	1.21	16.3
5.2	.44	171	2.38	-102	.012	-41	.94	175	1.92	17.5
5.4	.58	174	2.24	-121	.022	108	.95	166	.13	21.0
5.6	.71	169	2.03	-138	.040	96	.88	159	.11	17.0
5.8	.78	163	1.76	-153	.060	88	.83	152	.02	14.7
6.0	.82	157	1.47	-168	.087	76	.79	147	.02	12.3
6.5	.90	137	1.06	161	.136	54	.72	135	.04	8.9
7.0	.93	120	.80	137	.179	41	.65	126	.12	6.5
7.5	.94	102	.69	111	.231	26	.61	116	.20	4.8
8.0	.93	78	.61	81	.279	9	.54	103	.39	3.4

Note:

1. Gain Calculations:

$$MAG = \frac{|S_{21}|}{|S_{12}|} \left(K \pm \sqrt{K^2 - 1} \right). \text{ When } K \leq 1, \text{ MAG is undefined and MSG values are used. } MSG = \frac{|S_{21}|}{|S_{12}|}, K = \frac{1 + |\Delta|^2 - |S_{11}|^2 - |S_{22}|^2}{2 |S_{12} S_{21}|}, \Delta = S_{11} S_{22} - S_{21} S_{12}$$

MAG = Maximum Available Gain

MSG = Maximum Stable Gain

NE8004 SERIES

TYPICAL SMALL SIGNAL COMMON SOURCE SCATTERING PARAMETERS

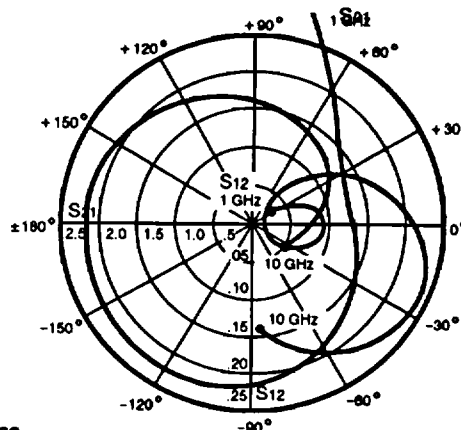
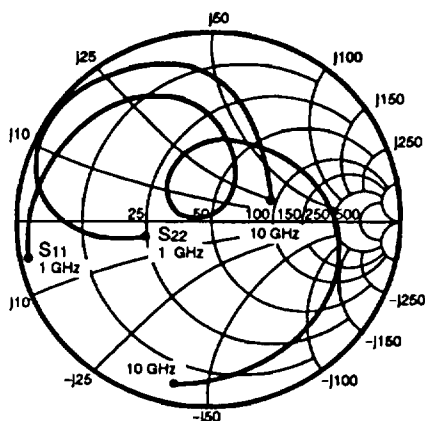

Coordinates in Ohms
Frequency in GHz
(V_{DS} = 9 V, I_{DS} = 600 mA)

NE800495-6

V_{DS} = 9 V, I_{DS} = 600 mA

FREQUENCY (GHz)	S ₁₁		S ₂₁		S ₁₂		S ₂₂		K	MAG (dB) ¹
	MAG	ANG	MAG	ANG	MAG	ANG	MAG	ANG		
0.1	.98	-62	14.81	146	.010	61	.21	-148	.12	31.8
0.2	.96	-100	10.95	125	.017	45	.28	-153	.16	28.1
0.5	.93	-146	5.45	97	.024	27	.34	-164	.41	23.5
1.0	.94	-169	3.00	76	.028	26	.36	-166	.57	20.3
1.5	.94	178	2.15	61	.031	30	.38	-165	.67	18.4
2.0	.93	170	1.74	46	.036	34	.42	-168	.87	16.9
2.5	.91	162	1.47	33	.042	35	.44	-169	1.02	14.5
3.0	.89	154	1.39	21	.050	35	.46	-170	1.07	12.8
3.5	.87	147	1.35	6	.059	30	.49	-171	.99	13.6
4.0	.84	136	1.44	-8	.070	26	.52	-172	.84	13.1
4.5	.79	124	1.50	-25	.079	18	.55	-174	.86	12.8
5.0	.71	109	1.68	-44	.088	9	.61	-176	.76	12.8
5.2	.65	101	1.74	-52	.090	3	.65	-177	.76	12.9
5.4	.59	93	1.86	-63	.093	-3	.69	-179	.71	13.0
5.6	.52	85	2.01	-74	.092	-10	.73	179	.65	13.4
5.8	.43	75	2.17	-86	.087	-15	.78	176	.61	13.9
6.0	.32	65	2.22	-99	.078	-24	.84	172	.58	14.6
6.2	.21	59	2.26	-114	.066	-31	.89	166	.56	15.4
6.4	.10	66	2.30	-128	.051	-35	.93	160	.53	16.6
6.6	.07	137	2.28	-143	.031	-23	.97	152	.49	18.6
6.8	.16	157	2.28	-157	.023	27	.99	145	.23	19.9
7.0	.25	148	2.27	-174	.042	50	.98	137	.08	17.3
7.5	.41	107	2.04	149	.126	37	.94	116	.01	12.1
8.0	.54	56	1.81	108	.192	12	.83	95	.10	9.8
8.5	.66	2	1.46	68	.233	-18	.66	73	.25	8.0
9.0	.77	-43	1.08	32	.217	-48	.50	53	.45	7.0
9.5	.85	-75	.78	1	.183	-70	.39	37	.59	6.3
10.0	.91	-98	.59	-23	.140	-85	.35	19	.67	6.2

Note:

1. Gain Calculations:

$$\text{MAG} = \frac{|S_{21}|}{|S_{12}|} \left(K \pm \sqrt{K^2 - 1} \right). \text{ When } K \leq 1, \text{ MAG is undefined and MSG values are used. } \text{MSG} = \frac{|S_{21}|}{|S_{12}|}, K = \frac{1 + |\Delta|^2 - |S_{11}|^2 - |S_{22}|^2}{2 |S_{12} S_{21}|}, \Delta = S_{11} S_{22} - S_{21} S_{12}$$

MAG = Maximum Available Gain

MSG = Maximum Stable Gain

TYPICAL SMALL SIGNAL COMMON SOURCE SCATTERING PARAMETERS

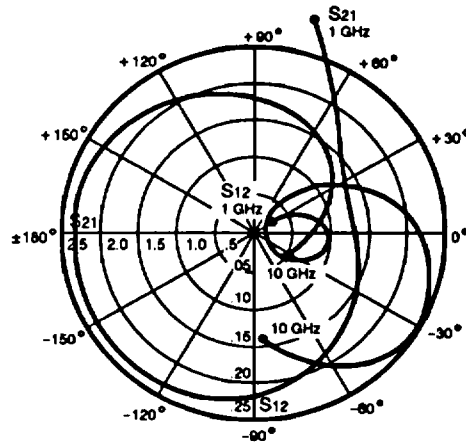
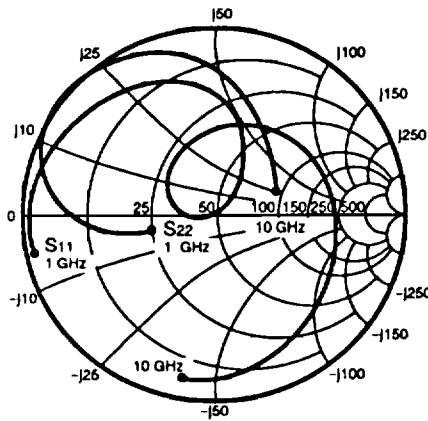

Coordinates in Ohms
Frequency in GHz
(V_{DS} = 9 V, I_{DS} = 600 mA)



NE800495-7

V_{DS} = 9 V, I_{DS} = 600 mA

FREQUENCY (GHZ)	S ₁₁		S ₂₁		S ₁₂		S ₂₂		K	MAG (dB) ¹
	MAG	ANG	MAG	ANG	MAG	ANG	MAG	ANG		
0.1	.99	-56	13.40	149	.008	65	.17	-147	.07	32.2
0.2	.97	-94	10.27	128	.015	50	.23	-150	.14	28.3
0.5	.94	-141	5.30	99	.023	29	.29	-159	.42	23.5
1.0	.95	-165	2.92	77	.027	26	.33	-161	.55	20.4
1.5	.95	-179	2.10	61	.028	29	.36	-159	.63	18.7
2.0	.94	-172	1.69	47	.032	34	.41	-162	.80	17.2
2.5	.92	164	1.43	34	.038	37	.44	-163	.98	15.8
3.0	.91	156	1.35	21	.044	37	.47	-164	.98	14.8
3.5	.89	147	1.29	7	.053	35	.51	-166	.98	13.9
4.0	.85	138	1.36	-7	.063	32	.54	-167	.95	13.4
4.5	.81	126	1.43	-22	.075	26	.57	-169	.84	12.8
5.0	.74	110	1.63	-40	.086	18	.63	-171	.69	12.7
5.5	.60	90	1.88	-64	.094	3	.72	-175	.57	13.0
6.0	.37	62	2.21	-94	.084	-15	.85	177	.44	14.2
6.2	.26	49	2.28	-108	.074	-22	.89	172	.41	14.9
6.4	.14	35	2.35	-122	.060	-28	.95	166	.31	15.9
6.6	.01	20	2.38	-138	.041	-22	.98	159	.26	17.7
6.8	.10	-175	2.40	-153	.030	15	.99	152	.22	19.0
7.0	.20	166	2.38	-170	.040	50	.99	144	.04	17.7
7.2	.29	147	2.34	175	.065	54	.98	135	.02	15.6
7.4	.36	126	2.30	158	.115	48	.96	126	.02	13.0
7.6	.43	104	2.26	143	.153	39	.93	117	.02	11.7
7.8	.48	80	2.16	125	.187	27	.91	108	.02	10.6
8.0	.53	54	2.03	108	.213	14	.84	97	.07	9.8
8.5	.66	-8	1.60	62	.252	-20	.61	73	.27	8.0
9.0	.77	-54	1.11	27	.222	-50	.41	55	.52	7.0
9.5	.87	-85	.79	-5	.180	-70	.31	46	.64	6.4
10.0	.92	-108	.57	-29	.140	-85	.30	30	.68	6.1

Note:

1. Gain Calculations:

$$MAG = \frac{|S_{21}|}{|S_{12}|} (K \pm \sqrt{K^2 - 1})$$

When K ≤ 1, MAG is undefined and MSG values are used. $MSG = \frac{|S_{21}|}{|S_{12}|}$, $K = \frac{1 + |\Delta|^2 - |S_{11}|^2 - |S_{22}|^2}{2 |S_{12} S_{21}|}$, $\Delta = S_{11} S_{22} - S_{21} S_{12}$

MAG = Maximum Available Gain

MSG = Maximum Stable Gain

NE8004 SERIES

TYPICAL SMALL SIGNAL COMMON SOURCE SCATTERING PARAMETERS

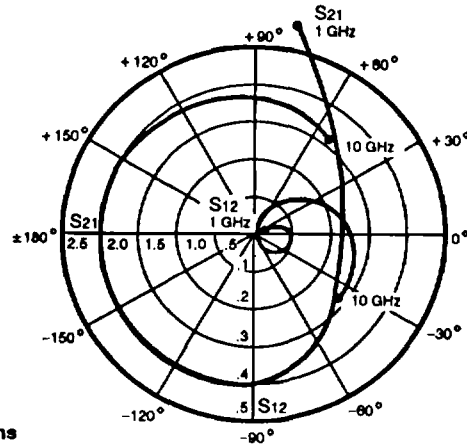
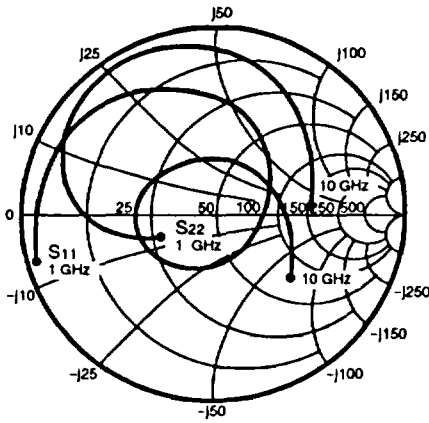

Coordinates in Ohms
Frequency in GHz
(V_{DS} = 9 V, I_{DS} = 600 mA)

NE800495-8

V_{DS} = 9 V, I_{DS} = 600 mA

FREQUENCY (GHz)	S ₁₁		S ₂₁		S ₁₂		S ₂₂		K	MAG (dB) ¹
	MAG	ANG	MAG	ANG	MAG	ANG	MAG	ANG		
0.1	.99	-54	12.92	150	.009	66	.18	-148	.09	31.4
0.2	.97	-91	10.00	129	.017	50	.24	-150	.15	27.8
0.5	.94	-140	5.23	100	.026	28	.31	-160	.38	23.1
1.0	.94	-165	2.89	78	.028	23	.34	-162	.50	20.1
1.5	.94	-179	2.06	62	.030	26	.37	-161	.66	18.4
2.0	.92	174	1.64	48	.033	23	.42	-164	.98	17.0
2.5	.92	166	1.37	35	.037	33	.45	-164	1.15	13.4
3.0	.91	159	1.27	24	.044	36	.48	-166	1.11	12.7
3.5	.90	152	1.20	10	.050	36	.51	-168	1.03	12.8
4.0	.87	143	1.23	-2	.062	32	.54	-170	.87	12.9
4.5	.84	132	1.23	-16	.072	28	.56	-174	.91	12.3
5.0	.79	119	1.33	-31	.085	22	.60	-177	.80	11.9
5.5	.71	102	1.49	-49	.099	10	.64	-180	.70	11.8
6.0	.59	78	1.72	-72	.105	-4	.72	175	.62	12.2
6.5	.39	40	1.87	-101	.103	-23	.80	167	.63	12.6
7.0	.26	-25	2.04	-130	.070	-42	.89	154	.64	14.6
7.2	.25	-61	2.05	-142	.052	-47	.92	148	.72	15.9
7.4	.28	-93	2.03	-157	.030	-43	.94	140	1.06	16.8
7.6	.32	-119	2.03	-168	.012	16	.94	133	2.46	15.4
7.8	.36	-140	2.02	177	.038	59	.94	126	.79	17.2
8.0	.39	-159	2.04	163	.069	59	.94	118	.46	14.7
8.2	.41	-177	2.03	150	.105	50	.94	108	.36	12.9
8.4	.41	164	1.99	136	.141	43	.91	99	.36	11.5
8.6	.39	144	1.96	121	.173	34	.88	88	.39	10.5
8.8	.36	121	1.90	106	.206	22	.83	76	.43	9.7
9.0	.33	94	1.84	90	.233	9	.78	64	.49	9.0
9.5	.36	15	1.60	50	.279	-20	.64	34	.58	7.6
10.0	.51	-38	1.28	17	.283	-48	.51	5	.68	6.6

Note:

1. Gain Calculations:

$$MAG = \frac{|S_{21}|}{|S_{12}|} \left(K \pm \sqrt{K^2 - 1} \right). \text{ When } K \leq 1, \text{ MAG is undefined and MSG values are used. } MSG = \frac{|S_{21}|}{|S_{12}|}, K = \frac{1 + |\Delta|^2 - |S_{11}|^2 - |S_{22}|^2}{2 |S_{12} S_{21}|}, \Delta = S_{11} S_{22} - S_{21} S_{12}$$

MAG = Maximum Available Gain

MSG = Maximum Stable Gain