

TQP887051

802.11a/n/ac WLAN Front End Module

Applications

- IEEE802.11a/n/ac WLAN Applications
- Single-Chip RF Front-end Module
- Wireless LAN Systems
- Portable Battery-Powered Equipment

Product Features

- Fully Integrated, 802.11a/n/ac front-end module
- Internally matched input/output
- Integrated directional detector
- Temperature Compensated Bias Network
- Single battery voltage of 3.2V- 4.6V
- Leadless 2.5 x 2.5 x 0.40 mm SMT Pb-Free
- Typ. Pout (+25C, V_{DD}=+3.6V) = 16dBm, EVM=1.78%, 802.11ac/MCS9/VHT80
- Typ. Pout (+25C, V_{DD}=+3.8V) = 19.7dBm, EVM=3.0%, 802.11n/MCS7
- Typ. Pout (+25C, V_{DD}=+3.8V) = 20.3dBm, EVM=4.6%, 64QAM, 54Mbps OFDM

General Description

The TQP887051 is full WLAN front-end module in an ultra small 2.5mm x 2.5mm footprint package for 802.11a/n/ac applications. The TQP887051 contains 5GHz PA, directional detector, front-end SPDT switch, and LNA with bypass mode. The architecture and interface are optimized for next generation WLAN integration into handset devices.

The front-end module features CMOS compatible control voltages to facilitate ease of use. With its low power dissipation, the front-end Module contributes to the extended battery life of next generation WLAN solutions.

The front-end module is manufactured in TriQuint's high-reliability E/D pHEMT technology and is assembled in ultra thin profile 2.5mm x 2.5mm x 0.40mm QFN - 16 Pb-Free Package.

Functional Block Diagram

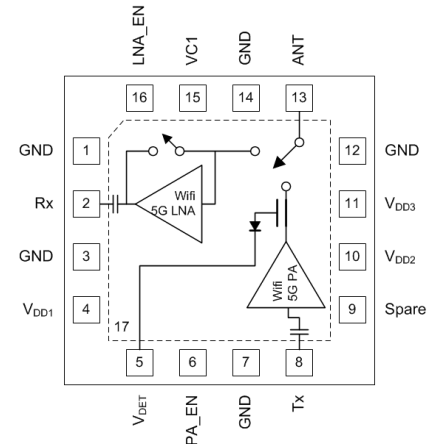

Pin Configuration

Pin #	Symbol
1, 3, 7, 12, 14, 17	GND
2	Rx output
4	Vdd1 LNA, PA 1 st stg, logic control
5	Vdet
6	PA_EN & TX switch pin
8	Tx
9	Spare, No connect
10	Vdd2 supply pin 5G PA 2 nd stg
11	Vdd3 supply pin 5G PA 3 rd stg
13	ANT
15	Vc1, control pin 5G RX
16	LNA_EN

Ordering Information

Part No.	Description
TQP887051	Packaged part

Standard T/R size = 2.5K pieces on a 7" reel.