

Fiber Optic Transmitter

OPF352



Features:

- 850 nm LED technology
- Popular ST[®] style receptacle
- Pre-tested with fiber to assure performance
- Component pre-mounted and ready to use
- 35MHz operation

Description:

The OPF352 fiber optic transmitters are high performance devices packaged for data communication links. This transmitter is an 850nm GaAlAs LED and is specifically designed to efficiently launch optical power into fibers ranging in size from 50/125µm up to 200/300µm diameter fiber. Multiple power ranges with upper and lower limits are offered which allows the designer to select a device best suited for the application.

This product's combination of features including high speed and efficient coupled power makes it an ideal transmitter for integration into all types of data communications equipment.

The mechanical design of this packaged is intended for PC Board or panel mounting. It is shipped with a lock washer, jam nut, 2 #2-56 screws, and a protective dust cap.

Applications:

- Power generation communication
- Industrial Ethernet equipment
- Copper-to-fiber media conversion
- Intra-system fiber optic links
- Video surveillance systems

Typical Coupled Power $I_f = 100\text{mA}, 25^\circ\text{C}$			
Fiber Size	Type	N.A.	OPF352A
50/125 µm	Graded Index	0.20	29µW
62.5/125 µm	Graded Index	0.28	83µW
100/140 µm	Graded Index	0.29	240µW
200/300 µm	Step Index	0.41	810µW

All Optek OPF LED emitters are AEL Class I as defined by IEC 60825-1 and are Risk Group 1 (Low-Risk) as defined by IEC 62471.



RoHS



ESD Class 2

ST[®] is a registered trademark of AT&T.

General Note

TT Electronics reserves the right to make changes in product specification without notice or liability. All information is subject to TT Electronics' own data and is considered accurate at time of going to print.

TT Electronics | OPTEK Technology
2900 E. Plano Pkwy, Plano, TX 75074 | Ph: +1 972 323 2200
www.ttelectronics.com | sensors@ttelectronics.com

Mechanical Data

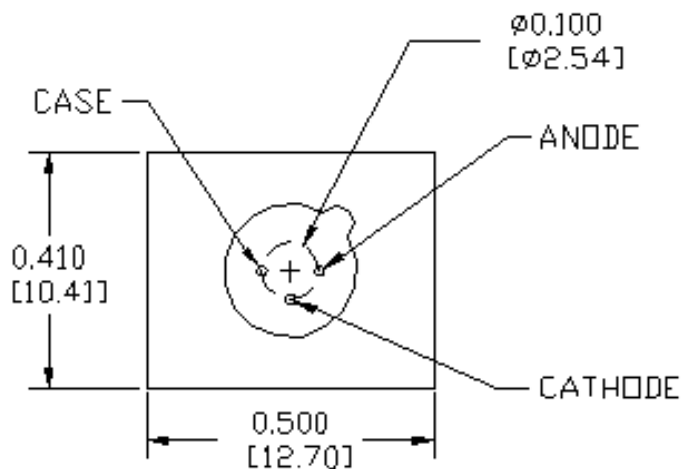
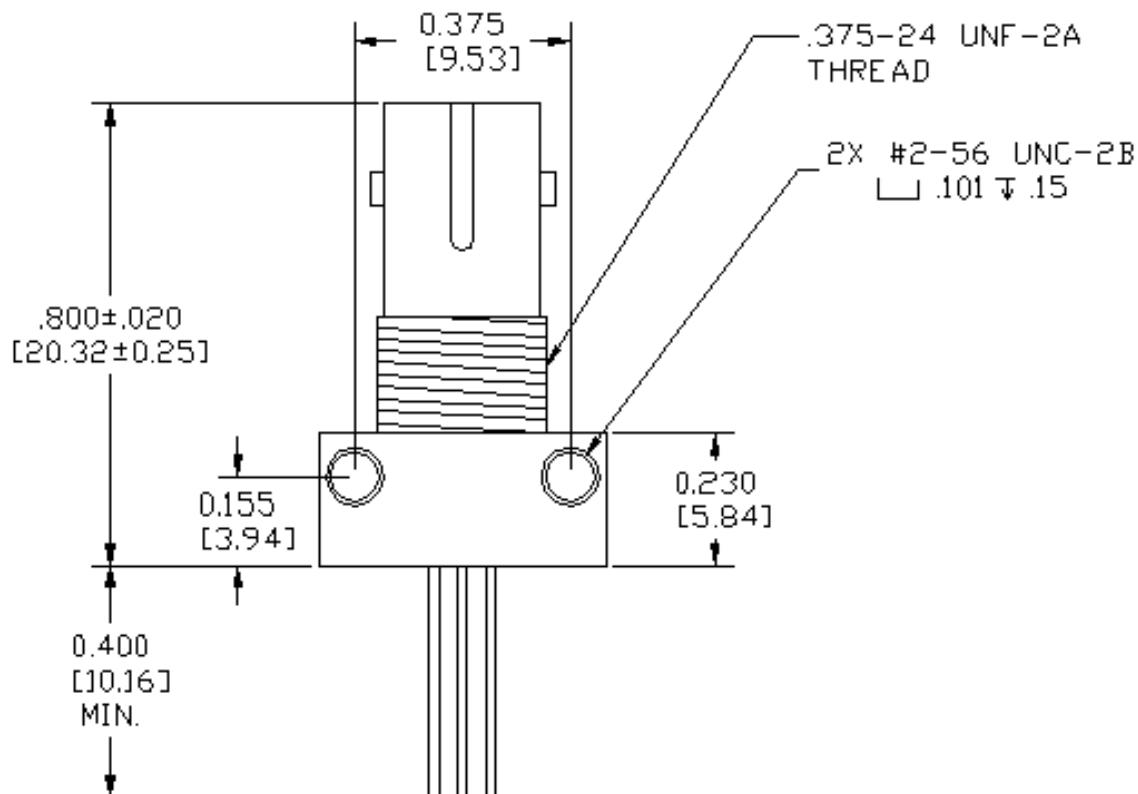

DIMENSIONS ARE IN INCHES (MILLIMETERS)

General Note

TT Electronics reserves the right to make changes in product specification without notice or liability. All information is subject to TT Electronics' own data and is considered accurate at time of going to print.

TT Electronics | OPTEK Technology
 2900 E. Plano Pkwy, Plano, TX 75074 | Ph: +1 972 323 2200
www.ttelectronics.com | sensors@ttelectronics.com

Electrical Specifications

Absolute Maximum Ratings ($T_A = 25^\circ\text{C}$ unless otherwise noted)

Storage Temperature Range	-55° C to +100° C
Operating Temperature Range	-40° C to +85° C
Lead Soldering Temperature ⁽¹⁾	260° C
Continuous Forward Current ⁽²⁾	100 mA
Maximum Reverse Voltage	1.0 V

Electrical Characteristics ($T_A = 25^\circ\text{C}$ unless otherwise noted)

SYMBOL	PARAMETER		MIN	TYP	MAX	UNITS	TEST CONDITIONS
P_{OC}	Total Coupled Power 50/125 μm Fiber, NA = 0.20	OPF352A	25.0	29.0		μW	$I_F = 100\text{ mA}$
V_F	Forward Voltage			1.8	2.2	V	$I_F = 100\text{ mA}$
V_R	Reverse Voltage		1.8			V	$I_R = 100\ \mu\text{A}$
λ	Wavelength		830	850	870	nm	$I_F = 50\text{ mA}$
$D\lambda$	Optical Bandwidth			50	60	nm	$I_F = 50\text{ mA}$
t_r, t_f	Rise and Fall Time			6.0	10.0	ns	$I_F = 100\text{ mA}; 10\% \text{ to } 90\%^{(3)}$

Notes:

- Maximum of 5 seconds with soldering iron. Duration can be extended to 10 seconds when flow soldering. RMA flux is recommended.
- De-rate linearly at 1.33mA /°C above 25°C .
- No Pre-bias.
- All Optek fiber optic LED products are subjected to 100% burn-in as part of its quality control process. The burn-in conditions are 96 hours at 100mA drive current and 25°C ambient temperature.

General Note

TT Electronics reserves the right to make changes in product specification without notice or liability. All information is subject to TT Electronics' own data and is considered accurate at time of going to print.

Performance

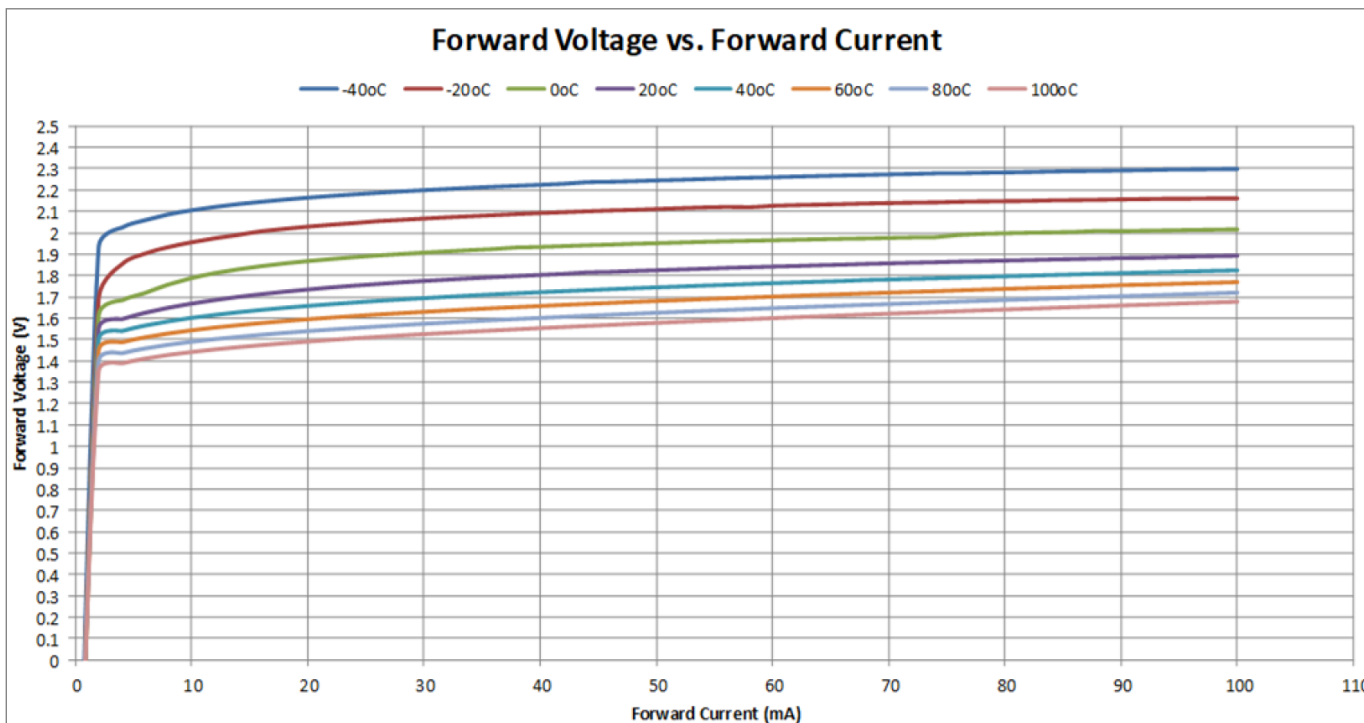
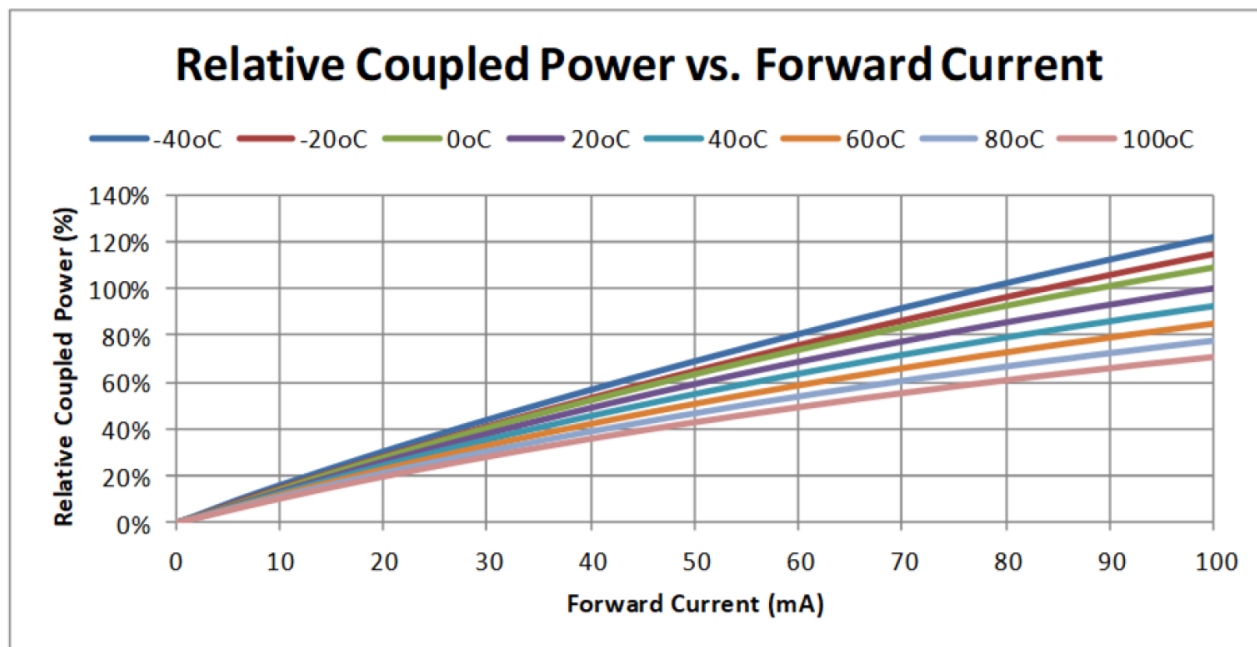

General Note

TT Electronics reserves the right to make changes in product specification without notice or liability. All information is subject to TT Electronics' own data and is considered accurate at time of going to print.

TT Electronics | OPTEK Technology
2900 E. Plano Pkwy, Plano, TX 75074 | Ph: +1 972 323 2200
www.ttelectronics.com | sensors@ttelectronics.com