

# SN5497, SN7497 SYNCHRONOUS 6-BIT BINARY RATE MULTIPLIERS

DECEMBER 1972—REVISED MARCH 1988

- Perform Fixed-Rate or Variable-Rate Frequency Division
- For Applications in Arithmetic, Radar, Digital-to-Analog (D/A), Analog-to-Digital (A/D), and other Conversion Operations
- Typical Maximum Clock Frequency . . . 32 Megahertz

## description

These monolithic, fully synchronous, programmable counters utilize Series 54/74 TTL circuitry to achieve 32-megahertz typical maximum operating frequencies. These six-bit serial binary counters feature buffered clock, clear, and enable inputs to control the operation of the counter, and a strobe input to enable or inhibit the rate input/decoding AND-OR-INVERT gates. The outputs have additional gating for cascading and transferring unity-count rates.

The counter is enabled when the clear, strobe, and enable inputs are low. With the counter enabled, the output frequency is equal to the input frequency multiplied by the rate input M and divided by 64, i.e.:

$$f_{out} = \frac{M \cdot f_{in}}{64}$$

$$\text{where: } M = F \cdot 2^5 + E \cdot 2^4 + D \cdot 2^3 + C \cdot 2^2 + B \cdot 2^1 + A \cdot 2^0$$

When the rate input is binary 0 (all rate inputs low), Z remains high. In order to cascade devices to perform 12-bit rate multiplication, the enable output is connected to the enable and strobe inputs of the next stage, the Z output of each stage is connected to the unity/cascade input of the other stage, and the sub-multiple frequency is taken from the Y output.

The unity/cascade input, when connected to the clock input, may be utilized to pass the clock frequency (inverted) to the Y output when the rate input/decoding gates are inhibited by the strobe. The unity/cascade input may also be used as a control for the Y output.

## logic symbol†

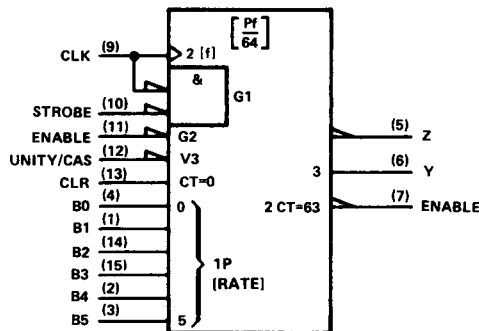

† This symbol is in accordance with ANSI/IEEE Std 91-1984 and IEC Publication 617-12.

PRODUCTION DATA documents contain information current as of publication date. Products conform to specifications per the terms of Texas Instruments standard warranty. Production processing does not necessarily include testing of all parameters.

TEXAS  
INSTRUMENTS

POST OFFICE BOX 655012 • DALLAS, TEXAS 75265

2-311

2

TTL Devices

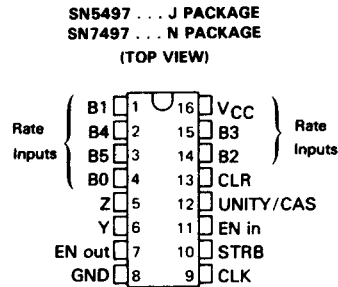

# SN5497, SN7497 SYNCHRONOUS 6-BIT BINARY RATE MULTIPLIERS

schematics of inputs and outputs

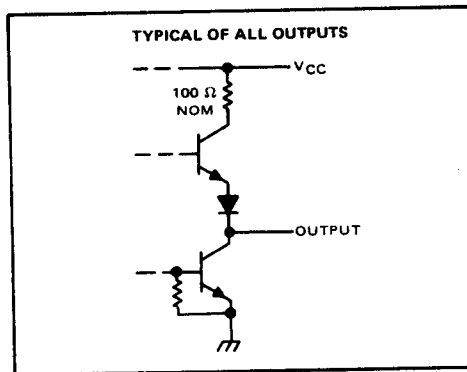
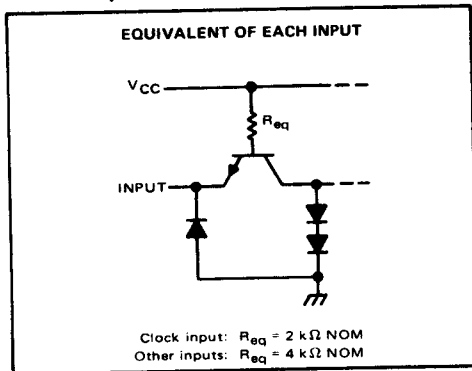

2

TTL Devices

STATE AND/OR RATE FUNCTION TABLE (See Note A)

CLEAR	ENABLE	STROBE	INPUTS						NUMBER OF CLOCK PULSES	UNITY/ CASCADE	OUTPUTS			NOTES
			BINARY RATE								LOGIC LEVEL OR NUMBER OF PULSES			
			B5	B4	B3	B2	B1	B0			Y	Z	ENABLE	
H	X	H	X	X	X	X	X	X	H	L	H	H	B	
L	L	L	L	L	L	L	L	64	H	L	H	1	C	
L	L	L	L	L	L	L	H	64	H	1	1	1	C	
L	L	L	L	L	L	H	L	64	H	2	2	1	C	
L	L	L	L	L	H	L	L	64	H	4	4	1	C	
L	L	L	L	L	H	L	L	64	H	8	8	1	C	
L	L	L	L	H	L	L	L	64	H	16	16	1	C	
L	L	L	L	H	L	L	L	64	H	32	32	1	C	
L	L	L	L	H	H	H	H	64	H	63	63	1	C	
L	L	L	H	H	H	H	H	64	L	H	63	1	D	
L	L	L	H	L	H	L	L	64	H	40	40	1	E	

- NOTES: A. H = high level, L = low level, X = irrelevant. All remaining entries are numeric counts.  
 B. This is a simplified illustration of the clear function. The states of clock and strobe can affect the logic level of Y and Z. A low unity/cascade will cause output Y to remain high.  
 C. Each rate illustrated assumes a constant value at rate inputs; however, these illustrations in no way prohibit variable-rate inputs.  
 D. Unity/cascade is used to inhibit output Y.  
 E.  $f_{out} = \frac{M \cdot f_{in}}{64} = \frac{(8 + 32) f_{in}}{64} = \frac{40 f_{in}}{64} = 0.625 f_{in}$

SN5497, SN7497  
 SYNCHRONOUS 6-BIT BINARY RATE MULTIPLIERS

logic diagram (positive logic)

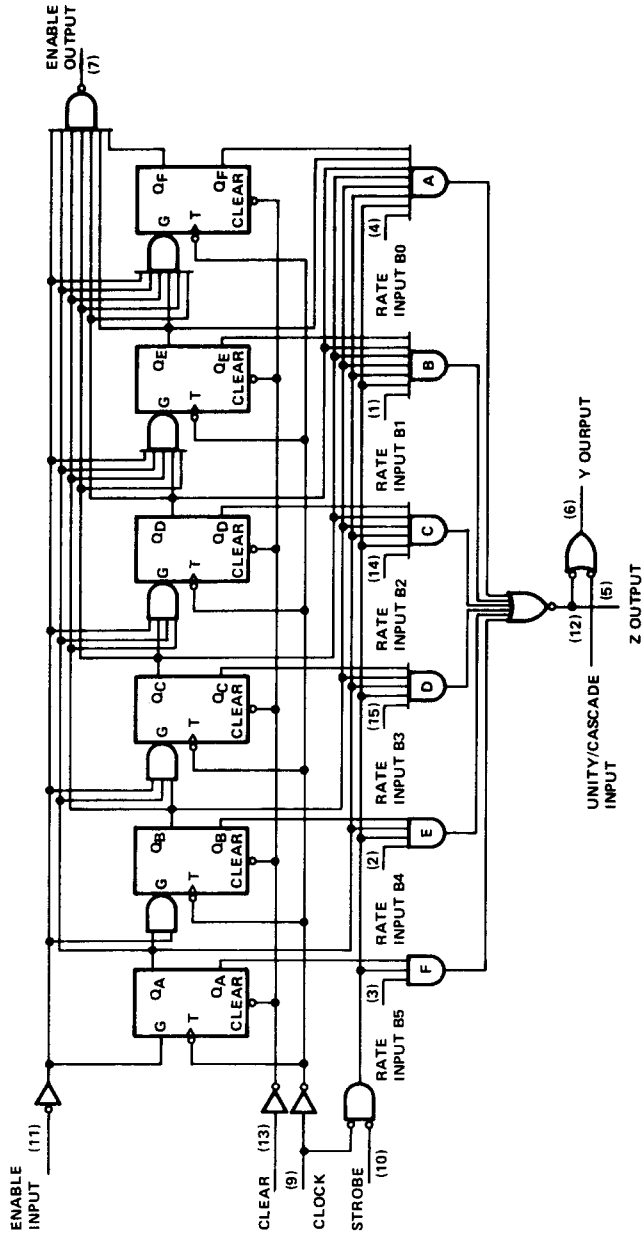

2

TTL Devices

# SN5497, SN7497 SYNCHRONOUS 6-BIT BINARY RATE MULTIPLIERS

absolute maximum ratings over operating free-air temperature range (unless otherwise noted)

Supply voltage, $V_{CC}$ (see Note 1)	7 V
Input voltage	5.5 V
Operating free-air temperature range: SN5497 (see Note 2)	-55°C to 125°C
SN7497	0°C to 70°C
Storage temperature range	-65°C to 150°C

recommended operating conditions

	SN5497		SN7497		UNIT
	MIN	NOM MAX	MIN	NOM MAX	
Supply voltage, $V_{CC}$	4.5	5	4.75	5	5.25 V
High-level output current, $I_{OH}$		-400		-400	$\mu$ A
Low-level output current, $I_{OL}$		16		16	mA
Clock frequency, $f_{clock}$	0	25	0	25	MHz
Width of clock pulse, $t_w(\text{clock})$	20		20		ns
Width of clear pulse, $t_w(\text{clear})$	15		15		ns
Enable setup time, $t_{su}$ : (See Figure 1)					
Before positive-going transition of clock pulse	25		25		ns
Before negative-going transition of previous clock pulse	0	$t_w(\text{clock})-10$	0	$t_w(\text{clock})-10$	
Enable hold time, $t_h$ : (See Figure 1)					
After positive-going transition of clock pulse	0	$t_w(\text{clock})-10$	0	$t_w(\text{clock})-10$	ns
After negative-going transition of previous clock pulse	20	$t_{cp}-10$	20	$t_{cp}-10$	
Operating free-air temperature, $T_A$ (See Note 2)	-55	125	0	70	°C

electrical characteristics over recommended operating free-air temperature range (unless otherwise noted)

PARAMETER		TEST CONDITIONS†	MIN	TYP‡	MAX	UNIT
$V_{IH}$	High-level input voltage			2		V
$V_{IL}$	Low-level input voltage				0.8	V
$V_{IK}$	Input clamp voltage	$V_{CC} = \text{MIN}, I_I = -12 \text{ mA}$			-1.5	V
$V_{OH}$	High-level output voltage	$V_{CC} = \text{MIN}, V_{IH} = 2 \text{ V}, V_{IL} = 0.8 \text{ V}, I_{OH} = -400 \mu\text{A}$	2.4	3.4		V
$V_{OL}$	Low-level output voltage	$V_{CC} = \text{MIN}, V_{IH} = 2 \text{ V}, V_{IL} = 0.8 \text{ V}, I_{OL} = 16 \text{ mA}$		0.2	0.4	V
$I_I$	Input current at maximum input voltage	$V_{CC} = \text{MAX}, V_I = 5.5 \text{ V}$			1	mA
$I_{IH}$	High-level input current	clock input			80	$\mu$ A
		other inputs	$V_{CC} = \text{MAX}, V_I = 2.4 \text{ V}$		40	
$I_{IL}$	Low-level input current	clock input			-3.2	mA
		other inputs	$V_{CC} = \text{MAX}, V_I = 0.4 \text{ V}$		-1.6	
$I_{OS}$	Short circuit output current§	$V_{CC} = \text{MAX}$		-18	-55	mA
$I_{CCH}$	Supply current, outputs high	$V_{CC} = \text{MAX},$ See Note 3		58		mA
$I_{CCL}$	Supply current, outputs low	$V_{CC} = \text{MAX},$ See Note 4		80	120	mA

†For test conditions shown as MIN or MAX, use the appropriate value specified under recommended operating conditions.

‡All typical values are at  $V_{CC} = 5 \text{ V}, T_A = 25^\circ \text{C}$ .

§Not more than one output should be shorted at a time.

- NOTES:
- Voltage values are with respect to network ground terminal.
  - An SN5497 in the W package operating at free-air temperatures above 118°C requires a heat sink that provides a thermal resistance from case to free-air,  $R_{\theta CA}$ , of not more than 55°C/W.
  - $I_{CCH}$  is measured with outputs open and all inputs grounded.
  - $I_{CCL}$  is measured with outputs open and all inputs at 4.5 V.

2  
TTL Devices

# SN5497, SN7497 SYNCHRONOUS 6-BIT BINARY RATE MULTIPLIERS

switching characteristics,  $V_{CC} = 5\text{ V}$ ,  $T_A = 25^\circ\text{C}$ ,  $N = 10$

PARAMETER <sup>†</sup>	FROM INPUT	TO OUTPUT	TEST CONDITIONS	MIN	TYP	MAX	UNIT
$f_{max}$			$C_L = 15\text{ pF}$ , $R_L = 400\ \Omega$ , See Figure 1	25	32		MHz
$t_{PLH}$	Enable	Enable		13	20		ns
$t_{PHL}$				14	21		
$t_{PLH}$	Strobe	Z		12	18		ns
$t_{PHL}$				15	23		
$t_{PLH}$	Clock	Y		26	39		ns
$t_{PHL}$				20	30		
$t_{PLH}$	Clock	Z		12	18		ns
$t_{PHL}$				17	26		
$t_{PLH}$	Rate	Z		6	10		ns
$t_{PHL}$				9	14		
$t_{PLH}$	Unity/Cascade	Y		9	14		ns
$t_{PHL}$				6	10		
$t_{PLH}$	Strobe	Y		19	30		ns
$t_{PHL}$				22	33		
$t_{PLH}$	Clock	Enable		19	30		ns
$t_{PHL}$				22	33		
$t_{PLH}$	Clear	Y		24	36		ns
$t_{PHL}$		Z		15	23		
$t_{PLH}$	Any Rate Input	Y		15	23		ns
$t_{PHL}$			15	23			

$f_{max}$  = maximum clock frequency.

$t_{PLH}$  = propagation delay time, low-to-high-level output.

$t_{PHL}$  = propagation delay time, high-to-low-level output.

## TYPICAL APPLICATION DATA

This application demonstrates how the '97 can be cascaded to perform 18-bit rate multiplication. This scheme is expandable to n-bits by extending the pattern illustrated.

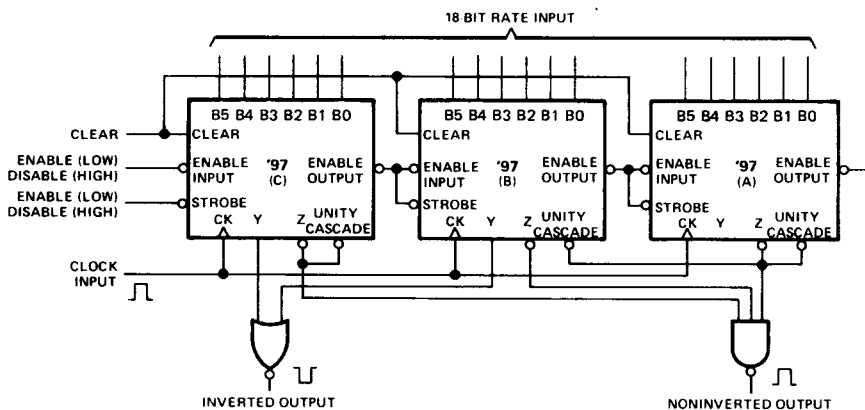

As illustrated, two of the 6-bit multipliers can be cascaded by connecting the Z output of unit A to the unity cascade input of unit B, in which case, a two-input NOR gate is used to cascade the remaining multipliers. Alternatively, all three Y outputs can be cascaded with a 3-input NOR gate. The three unused unity cascade inputs can be conveniently terminated by connecting each to its Z output.

2  
TTL Devices

PARAMETER MEASUREMENT INFORMATION

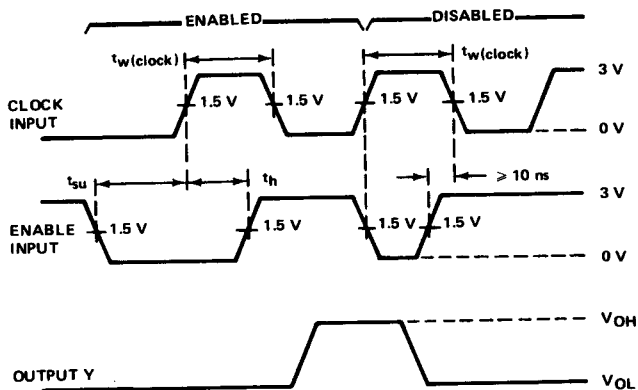

ENABLING FROM POSITIVE-GOING  
 TRANSITION OF CLOCK PULSE

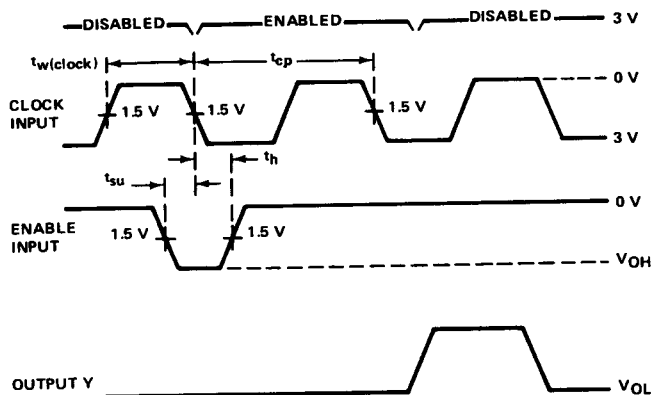

ENABLING FROM NEGATIVE-GOING  
 TRANSITION OF PREVIOUS CLOCK PULSE

1. Unity/Cascade and pin 2 (rate input), other inputs are low. Clear the counter and apply clock and enable pulse as illustrated.
2. Setup and hold times are illustrated for enabling a single clock pulse (count). Continued application of the enable function will enable subsequent clock pulse (counts) until disabling occurs (enable goes high). The total number of counts will be determined by the total number of positive-going clock transition enabled.

NOTES: A. The input pulse generator has the following characteristics:  $t_w(\text{clock}) = 20 \text{ ns}$ ,  $t_{TLH} \leq 10 \text{ ns}$ ,  $t_{THL} \leq 10 \text{ ns}$ ,  $\text{PRR} = 1 \text{ MHz}$ ,  $Z_{\text{out}} \approx 50 \Omega$ .  
 B.  $C_L$  includes probe and jig capacitance.  
 C. All diodes are 1N3064 or equivalent.

FIGURE 1—SWITCHING TIMES

2

TTL Devices

PARAMETER MEASUREMENT INFORMATION

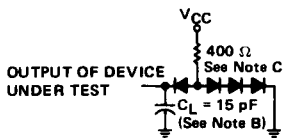

All three outputs are loaded during testing.  
**LOAD CIRCUIT**

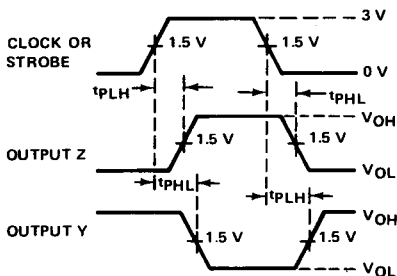

Unity/cascade and rate inputs are high, other inputs are low, and flip-flops are at any count other than maximum.

**PROPAGATION DELAY TIMES, CLOCK TO Z AND Y, AND STROBE INPUT TO Z AND Y**

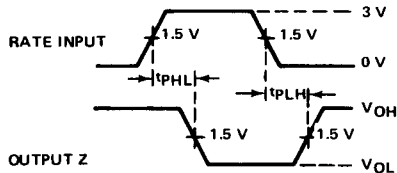

Flip-flops are at a count so that all other inputs to the gate under test are high and all other inputs, including other rate inputs, are low.

**PROPAGATION DELAY TIMES, RATE INPUT TO Z**

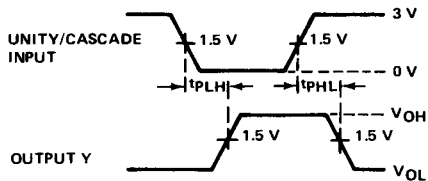

Output Z is high.

**PROPAGATION DELAY TIMES, UNITY/CASCADE INPUT TO Y**

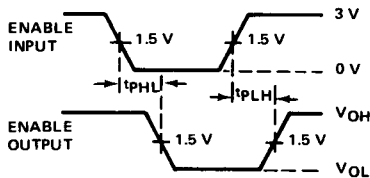

Flip-flops are at the maximum count. Other inputs are low.

**PROPAGATION DELAY TIMES, ENABLE INPUT TO ENABLE OUTPUT**

- NOTES: A. The input pulse generator has the following characteristics:  $t_w(\text{clock}) = 20 \text{ ns}$ ,  $t_{TLH} \leq 10 \text{ ns}$ ,  $t_{THL} \leq 10 \text{ ns}$ ,  $\text{PRR} = 1 \text{ MHz}$ ,  $Z_{out} \approx 50 \Omega$ .  
 B.  $C_L$  includes probe and jig capacitance.  
 C. All diodes are 1N3064 or equivalent.

FIGURE 1—SWITCHING TIMES (CONTINUED)