

QUAD T1/E1 LINE INTERFACE UNIT

FEATURES

- Monolithic single chip device which integrates four full-featured T1/E1 duplex DSX-1 compatible line interface circuits in a single device.
- Supports B8ZS, HDB3, and AMI line codes.
- Provides receive clock recovery and line performance monitoring. Provides transmit jitter attenuation with programmable line build out.
- Directly interfaces to the PM4344 TQUAD Quad T1 Framer, PM6344 EQUAD Quad E1 Framer, PM8313 D3MX M13 Multiplexer, and PM7344 S/UNI-MPH Quad T1/E1 Saturn ATM User Network Interface. Software compatible with the PM4341A T1XC single channel T1 Transceiver and with the PM6341 E1XC single channel E1 Transceiver.
- Provides an 8-bit microprocessor bus interface for configuration, control, and status monitoring. Also supports a hardware only operational mode.
- Low power CMOS technology
- Available in a rectangular 128 pin PQFP (14 by 20mm) package.
- -40 to +85 degree Industrial temperature operation.

APPLICATIONS

- T1 Channel Service Units (CSU)
- T1/E1 Multiplexers and Digital Private Branch Exchanges (PBX)
- Digital Access and Cross-Connect Systems (DACS) and Electronic DSX Cross-Connect Systems (EDSX)
- T1/E1 Frame Relay Interfaces
- T1/E1 ATM Interfaces
- T1/E1 ATM Circuit Emulation Interfaces
- SONET Add/Drop Multiplexers (ADM)
- T1/E1 Test and Performance Monitoring Equipment

RECEIVE SECTIONS

- Provides dual or single rail digital PCM outputs.
- Supports reception of G.703 signals with up to 6 dB attenuation and reception of DSX-1 compatible signals using an external 1:2 turns ratio transformer and passive components.

- Provides loss of signal and AIS alarm detection. Detects violations of the ANSI T1.403 12.5% pulse density rule over a moving 192 bit window.
- Minimum sensitivity of 75 mV with a 1:2 turns ratio transformer allows for terminating or bridged performance monitoring applications.
- Accommodates up to 0.4 UI peak-to-peak, high frequency jitter as required by AT&T TR 64211.
- Detects line code violations (LCVs), and accumulates up to 8191 line code violations (LCVs) for performance monitoring purposes.
- Detects both programmable inband loopback activate and deactivate code sequences received in the DS-1/E1 data stream.

TRANSMIT SECTIONS

- Optionally accepts dual rail digital PCM inputs. Accepts gapped data streams to support higher rate demultiplexing. Supports unframed mode.

- Optionally performs B8ZS or HDB3 encoding for single rail PCM signals.
- Generates DSX-1 compatible pulses with programmable pulse shape using only an external 1:1.36 turns ratio transformer.
- Accommodates standard cable types such as ABAM, PIC and Coax.
- Selectable line length and line type for DS-1 transmit pulse build out.
- Detects violations of the ANSI T1.403 12.5% pulse density rule over a moving 192 bit window.
- Allows insertion of framed or unframed in-band loopback code sequences.
- Supports transmission of the alarm indication signal (AIS).
- Provides a 48 bit FIFO for jitter attenuation in each transmit path. FIFO full or empty indications allow for bit-stuffing in higher rate multiplexing applications.
- Provides up to 55 dB of jitter attenuation as per AT&T TR 62411.

BLOCK DIAGRAM

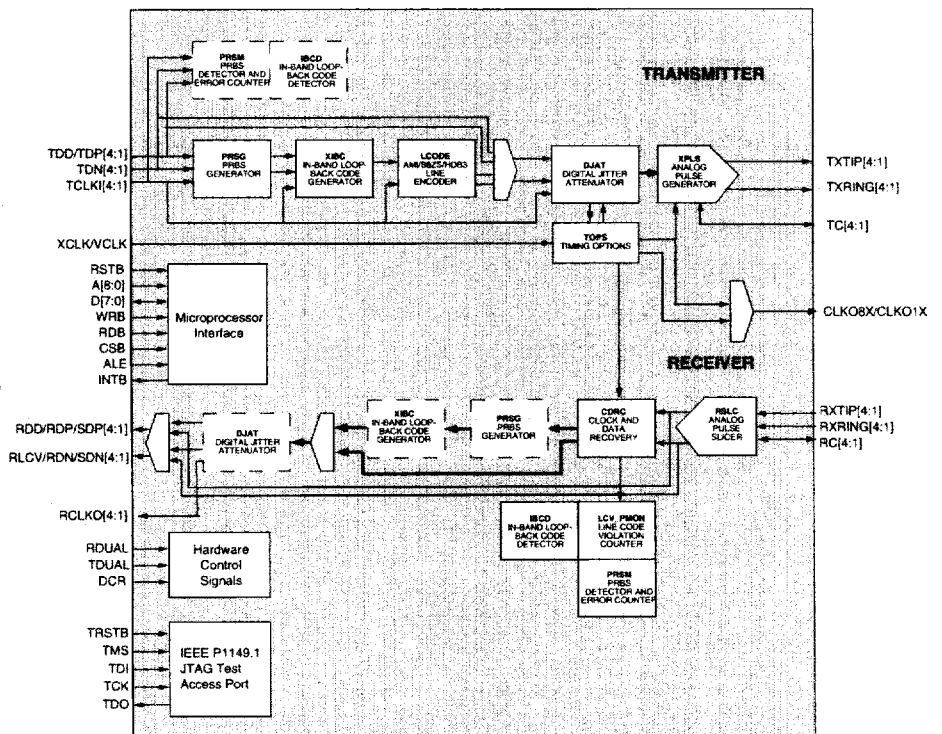

QUAD T1/E1 LINE INTERFACE UNIT

TYPICAL APPLICATIONS:

High Density HDLC Application

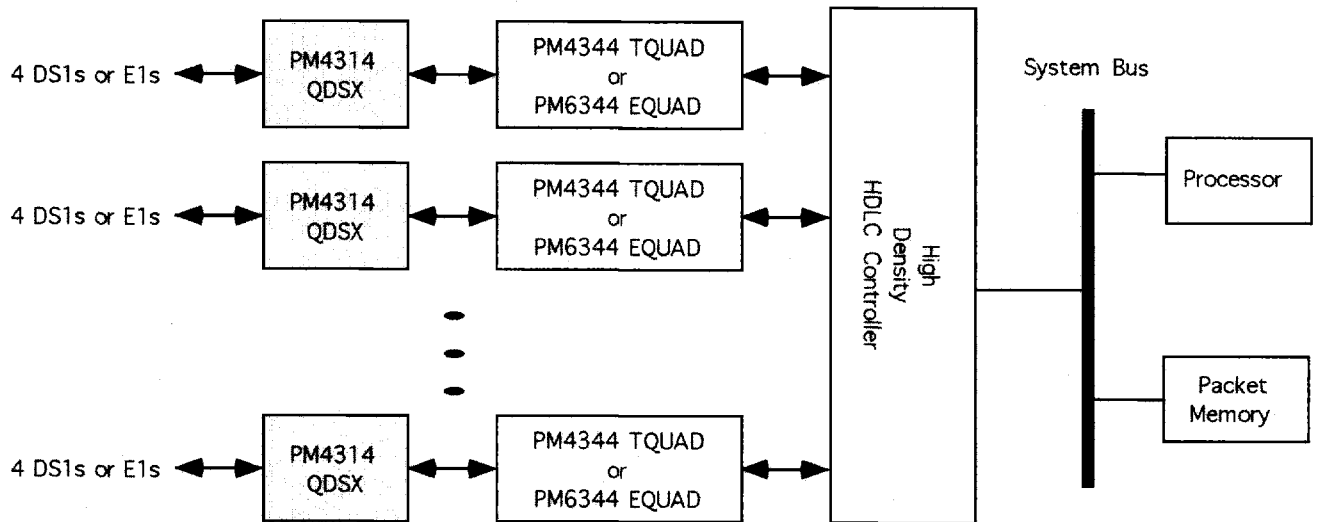

T1 or E1 Multi-PHY ATM UNI

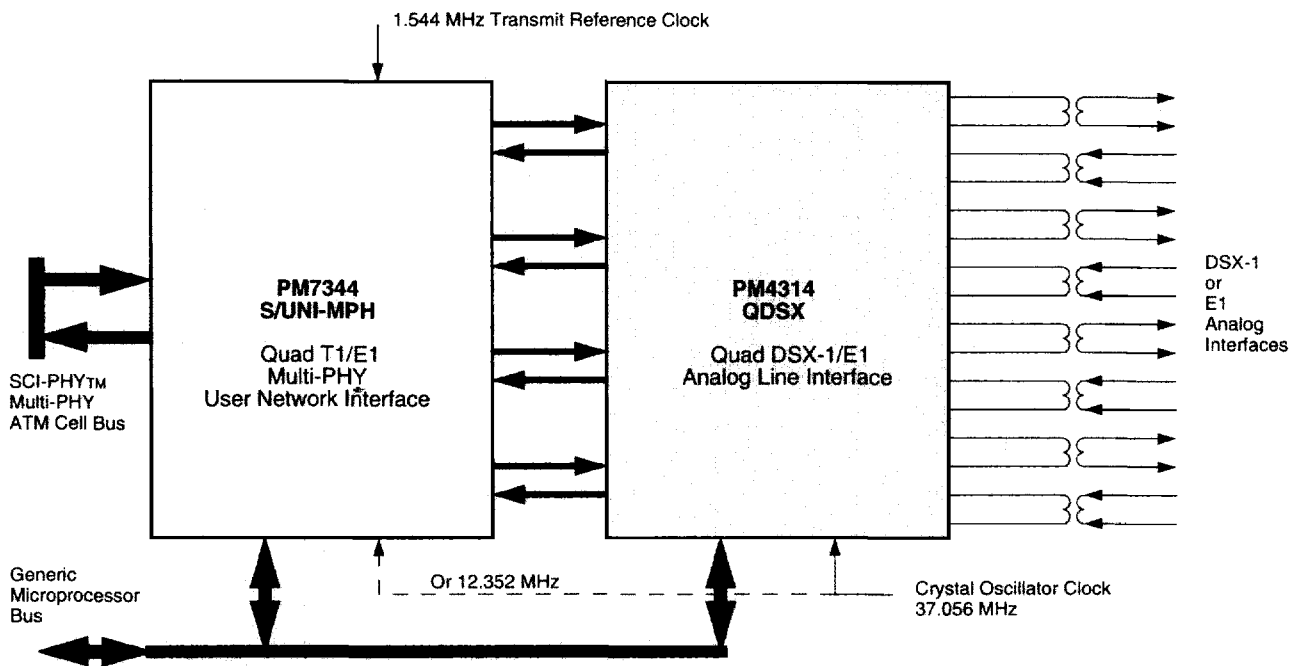

Head Office:
PMC-Sierra, Inc.
Suite 105 - 8555 Baxter Place
Burnaby, B.C. V5A 4V7
Canada
Tel: 604.415.6000
Fax: 604.415.6200

To order documentation,
send email to:
document@pmc-sierra.com
or contact the head office,
Attn: Document Coordinator

All product documentation is
available on our web site at:
<http://www.pmc-sierra.com>
For corporate information,
send email to:
info@pmc-sierra.com

S/UNI®, SATURN® and
UNI-PHY™ are trademarks
of PMC-Sierra, Inc.

PMC-941034(R4)

© 1997
PMC-Sierra, Inc.
March, 1997