



+1.8V, Low Power , 16-Bit Sigma - Delta A/D Converter

FEATURES

- 16-Bit Resolution at Eight Conversions Per Second, Adjustable Down to 10-Bit Resolution at 512 Conversions Per Second
- 1.8V – 5.5V Operation, Low Power Operating 260µA Sleep: 0.75µA
- MicroPort™ Serial Bus Requires Only Two Interface Lines
- Uses Internal or External Reference
- Automatically Enters Sleep Mode When Not In Use
- 8-Pin SOIC and 8-Pin PDIP Packages

TYPICAL APPLICATIONS

- Consumer Electronics, Thermostats, CO Monitors, Humidity Meters, Security Sensors
- Embedded Systems, Data Loggers, Portable Equipment
- Medical Instruments

GENERAL DESCRIPTION

The TC3400 is a low cost, low power analog-to-digital converter based on Microchip's Sigma-Delta technology. It will perform 16-bit conversions (15-bit plus sign) at up to eight per second. The TC3400 is optimized for use as a microcontroller peripheral in low cost, battery operated systems. A voltage reference is included, or an external reference can be used.

The TC3400's 2-wire MicroPort™ digital interface is used for starting conversions and for reading out the data. Driving the SCLK line low starts a conversion. After the conversion starts, each additional falling edge (up to six) detected on SCLK for t4 seconds reduces the A/D resolution by one bit and cuts conversion time in half. After a conversion is completed, clocking the SCLK line puts the MSB through LSB of the resulting data word onto the SDAT line, much like a shift register. The part automatically sleeps when not performing a data conversion.

The TC3400 is available in 8-Pin PDIP and 8-Pin SOIC packages.

ORDERING INFORMATION

Part No.	Package	Temp. Range
TC3400VPA	8-Pin PDIP (Narrow)	0°C to +85°C
TC3400VOA	8-Pin SOIC (Narrow)	0°C to +85°C

TYPICAL APPLICATION

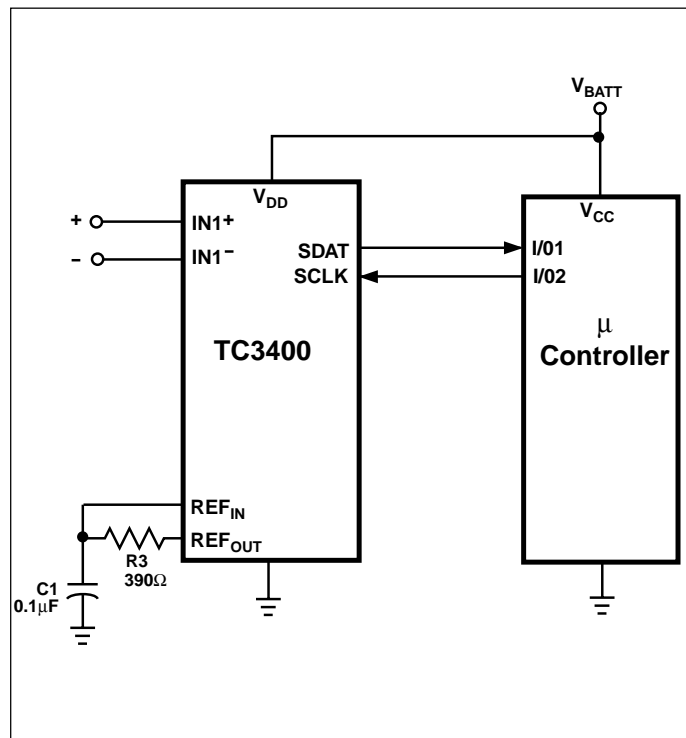

PIN CONFIGURATIONS

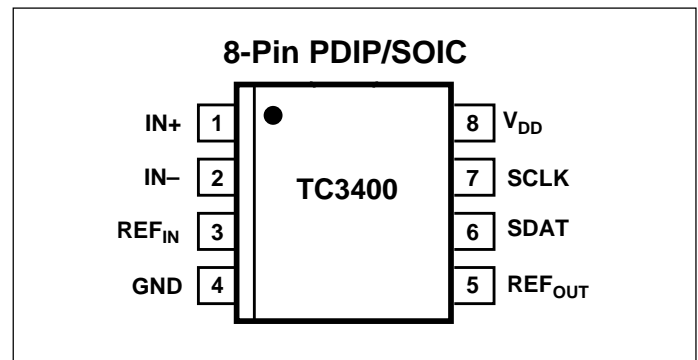

+1.8V, Low Power , 16-Bit Sigma - Delta A/D Converter

TC3400

ABSOLUTE MAXIMUM RATINGS*

Supply Voltage	6.0V
Input Voltage (All Other Pins)	(GND – 0.3V) to (V _{DD} + 0.3V)
Operating Temperature	0°C to 85°C
Maximum Chip Temperature	+150°C
Storage Temperature Range	– 65°C to +150°C
Lead Temperature (Soldering, 10 sec)	+300°C

*Static-sensitive device. Unused devices must be stored in conductive material. Protect devices from static discharge and static fields. Stresses above those listed under Absolute Maximum Ratings may cause permanent damage to the device. These are stress ratings only and functional operation of the device at these or any other conditions above those indicated in the operational sections of the specifications is not implied. Exposure to Absolute Maximum Rating Conditions for extended periods may affect device reliability.

DC ELECTRICAL CHARACTERISTICS: T_A = 25°C and V_{DD} = 2.7V, unless otherwise specified. Specifications in Bold type apply over a temperature range of 0°C to 85°C. V_{REF} = 1.25V, Internal Clock Freq = 520kHz

Symbol	Parameter	Test Conditions	Min	Typ	Max	Unit
POWER SUPPLY						
V _{DD}	Supply Voltage		1.8	—	5.5	V
I _{DD}	Supply Current, During Data Conversion		—	260	—	μA
I _{DD(SLEEP)}	Supply Current, Sleep Mode	T _A = +25°C	—	0.75	1.5	μA
I _{DD(SLEEP)}			—	1.2	3.0	μA
ACCURACY (Differential Inputs)						
RES	Resolution		—	16	—	Bits
INL	Integral Non-Linearity	V _{DD} = 2.7V	—	.0038	—	%FSR
V _{OS}	Offset Error	IN ⁺ = IN [–] = 0V	—	—	±1.0	%FSR
V _{NOISE}	Referred to input		—	60	—	μVrms
CMR	Common Mode Rejection	at DC	—	75	—	dB
FSE	Full Scale Error		—	0.4%	—	%FS
PSRR	Power Supply Rejection Ratio	V _{DD} = 2.5V to 3.5V	—	75	—	dB
IN⁺, IN[–]						
V _{IN±}	Differential Input Voltage	(Note 1)	—	—	2.5	V
	Absolute Voltage Range on IN ⁺ , IN [–]		GND	—	V _{DD}	V
	Input Bias Current		—	1	100	nA
C _{IN}	Input Sampling Capacitance		—	2	—	pF
R _{IN}	Differential Input Resistance	(Note 2)	—	2.0	—	MΩ
REF_{IN}, REF_{OUT}						
V _{REF}	REF _{IN} Voltage Range		0	—	1.25	V
I _{REF}	REF _{IN} Input Current		—	1	—	μA
V _{REFOUT}	REF _{OUT} Voltage		—	1.193	—	V
REF _{SINK}	REF _{OUT} Current Sink Capability		—	10	—	μA
REF _{SRC}	REF _{OUT} Current Source Capability		300	—	—	μA
SCLK						
V _{IL}	Input Low Voltage		—	—	0.3 x V_{DD}	V
V _{IH}	Input High Voltage		0.7 x V_{DD}	—	—	V
I _{LEAK}	Leakage Current		—	1	—	μA

Notes: 1. Differential input voltage defined as (V_{IN+} – V_{IN–})
2. Resistance from IN_{n+} to IN_{n–} or IN_n to GND.

3-1/2 Digit Analog-to-Digital Converters

TC3400

DC ELECTRICAL CHARACTERISTICS (CONT.): $T_A = 25^\circ\text{C}$ and $V_{DD} = 2.7\text{V}$, unless otherwise specified. Specifications in Bold type apply over a temperature range of 0°C to 85°C .

Symbol	Parameter	Test Conditions	Min	Typ	Max	Unit
SDAT						
V_{OL}	Output Low Voltage	$I_{OL} = 1.5\text{mA}$	—	—	0.4	V
V_{OH}	Output High Voltage (SDAT)	$I_{SOURCE} = 400\mu\text{a}$ (Note 2)	$0.9 \times V_{DD}$	—	—	V

AC ELECTRICAL CHARACTERISTICS: $T_A = 25^\circ\text{C}$ and $V_{DD} = 2.7\text{V}$, unless otherwise specified. Specifications in Bold type apply over a temperature range of 0°C to 85°C . $V_{REF} = 1.25\text{V}$, Internal Clock Freq = 520kHz

Symbol	Parameter	Description	Min	Typ	Max	Unit
t_1		Width of SCLK (Negative)	1	—	—	μsec
t_2	Resolution Reduction Clock Width	Width of SCLK (Positive)	1	—	—	μsec
t_3	Conversion Time (15-Bit Plus Sign)	16-bit conversion, $T_A = 25^\circ$ (Note 1)	—	125	—	msec
	Conversion Time (14-Bit Plus Sign)	15-bit conversion	—	$t_3/2.0$	—	msec
	Conversion Time (13-Bit Plus Sign)	14-bit conversion	—	$t_3/4.0$	—	msec
	Conversion Time (12-Bit Plus Sign)	13-bit conversion	—	$t_3/7.8$	—	msec
	Conversion Time (11-Bit Plus Sign)	12-bit conversion	—	$t_3/15.1$	—	msec
	Conversion Time (10-Bit Plus Sign)	11-bit conversion	—	$t_3/28.6$	—	msec
	Conversion Time (9-Bit Plus Sign)	10-Bit conversion	—	$t_3/51.4$	—	msec
	t_4	Resolution Reduction Window	Width of SCLK	—	$t_3/85.7$	—
t_5	SCLK to Data Valid	SCLK falling edge to SDAT valid	1000	—	—	nsec
t_8	Acknowledge Delay	SCLK to SDAT delay	—	—	1000	nsec

- Notes: 1. Nominal temperature drift is $-2830 \text{ ppm}/^\circ\text{C}$ for temperature less than 25°C and $-1340 \text{ ppm}/^\circ\text{C}$ for temperatures greater than 25°C .
 2. @ $V_{DD} = 1.8\text{V}$, $I_{SOURCE} \leq 200\mu\text{a}$

+1.8V, Low Power , 16-Bit Sigma - Delta A/D Converter

TC3400

PIN DESCRIPTION

TC3400 Pin No.	Name	Description
1	IN ⁺	Analog Input. This is the positive terminal of a true differential input consisting of IN ⁺ and IN ⁻ . $V_{IN(n)} = (IN^+ - IN^-)$. (See <i>Electrical Characteristics</i> .)
2	IN ⁻	Analog Input. This is the negative terminal of a true differential input consisting of IN ⁺ and IN ⁻ . $V_{IN} = (IN^+ - IN^-)$ IN ⁻ can swing to, but not below, ground. (See <i>Electrical Characteristics</i> .)
3	REF _{IN}	Analog Input. The converter's reference voltage is the differential between this pin and ground times two. It may be connected to REF _{OUT} as shown on page 1 or scaled using a resistor divider. Any user supplied reference voltage less than 1.25V may be used in place of V _{REFOUT} .
4	GND	Ground Terminal.
5	REF _{OUT}	Analog Output. The internal reference connects to this pin. It may be scaled externally, if desired, and tied to the REF _{IN} input to provide the converter's reference voltage. Care must be taken in connecting external circuitry to this pin. (See <i>Electrical Characteristics</i> .)
6	SDAT	Digital Output (push-pull). This is the MicroPort™ serial data output. SDAT is driven low while the TC3400 is converting data, effectively providing a "busy" signal. After the conversion is complete, every high- to-low transition on the SCLK pin puts a bit from the resulting data word on the SDAT pin (from MSB to LSB).
7	SCLK	Digital Input. This is the MicroPort™ serial clock input. After the conversion starts, each additional falling edge (up to six) detected on SCLK for t ₄ seconds reduces the A/D resolution by one bit. When the conversion is complete, the data word can be shifted out on the SDAT pin by clocking the SCLK pin.
8	V _{DD}	Power Supply Input. (See <i>Electrical Characteristics</i> .)

GENERAL THEORY OF OPERATION

The TC3400 is a 16-bit sigma-delta A/D converter with one differential input. The detailed description of the key components of the TC3400 is outlined below. (Also refer to the A/D Operational Flowchart on page 9 and the Timing Diagrams in Figures 2 through 4).

A/D Converter Operation

When the TC3400 is not converting, it is in sleep mode with both the SCLK and SDAT lines high. An A/D conversion is initiated by a high to low transition on the SCLK line at which time the internal clock of the TC3400 is started. Each additional high to low transition of SCLK (following the initial SCLK falling edge) and during the time interval t_4 will decrement the conversion accuracy by one bit and reduce the conversion time by one half. The time interval t_4 is referred to as the resolution reduction window. The minimum conversion resolution is 10 bits so any more than 6 SCLK transitions during t_4 will be ignored.

After each high to low transition of SCLK, in the t_4 interval, the SDAT output is driven high by the TC3400 to acknowledge that the conversion has been decremented. When the SCLK returns high or the t_4 interval ends, the SDAT line returns low (see Figure 2). When the conversion is complete SDAT is driven high. The 3400 now enters sleep mode and the conversion value can be read as a serial data word on the SDAT line.

Reading the Data Word

After the conversion is complete and SDAT goes high, the conversion value can be clocked serially onto the SDAT line by high to low transitions of the SCLK. The data word is in two's complement format with the sign bit clocked onto the SDAT line first followed by the MSB and ending in the LSB. For a 16 bit conversion the data word would consist of a sign bit followed by 15 magnitude bits, Table 1 shows the data word versus input voltage for a 16 bit conversion. Note that the full scale input voltage range is $\pm(2 \text{ REF}_{\text{IN}} - 1 \text{ LSB})$. When REF_{OUT} is fed back directly to REF_{IN} , an LSB is $73\mu\text{V}$ for a 16 bit conversion, as REF_{OUT} is typically 1.193V.

Figure 3 shows typical SCLK and SDAT waveforms for 16, 12 and 10 bit conversions. Note that any complete convert and read cycle requires 17 negative edge clock pulses. The first is the convert command. Then, up to six of these can occur in the resolution reduction window, t_4 , to decrement accuracy. The remaining pulses clock out the conversion data word.

Table 1. Data Conversion Word vs. Voltage Input ($\text{REF}_{\text{IN}} = 1.193\text{V}$)

Data Word	$\text{INn}^+ - \text{INn}^-$ (Volts)
0111 1111 1111 1111	2.38596 (Positive Full Scale)
0000 0000 0000 0001	$72.8 \text{ E} - 6$
0000 0000 0000 0000	0
1111 1111 1111 1111	$-72.8 \text{ E} - 6$
1000 0000 0000 0001	-2.38596 (Negative Full Scale)
1000 0000 0000 0000	Reserved Code

The SCLK input has a filter which rejects any positive or negative pulse of width less than 50nsec to reduce noise. The rejection width of this pulse can vary between 50nsec and 750nsec depending on processing parameters and supply voltage.

Figure 3 shows a truth table for determining the mode of operation for the TC3400 part by recording the value of SDAT for SCLK in a high, then low, then high state. For example, if SCLK goes through a 1-0-1 transition and the corresponding values of SDAT are 1-1-0, then the SCLK falling edge started a new data conversion. A 0-1-0 for SDAT would have indicated a resolution reduction had occurred. This is useful if the microcontroller has a watchdog reset or otherwise loses track of where the TC3400 part is in the conversion and data readout sequence. The microcontroller can simply transition SCLK until it "finds" a Start Conversion condition.

+1.8V, Low Power , 16-Bit Sigma - Delta A/D Converter

TC3400

FUNCTIONAL BLOCK DIAGRAM

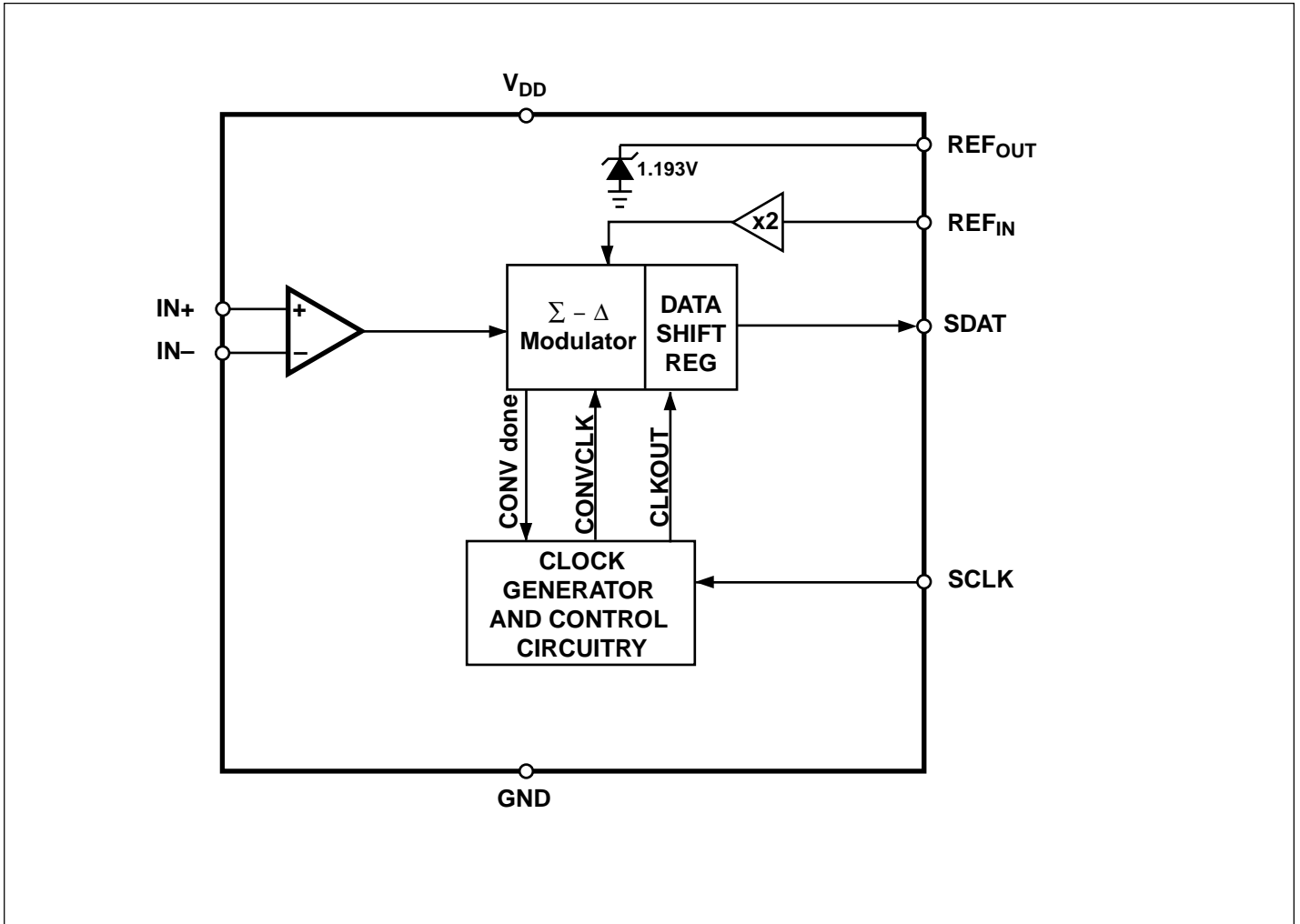

TIMING DIAGRAMS

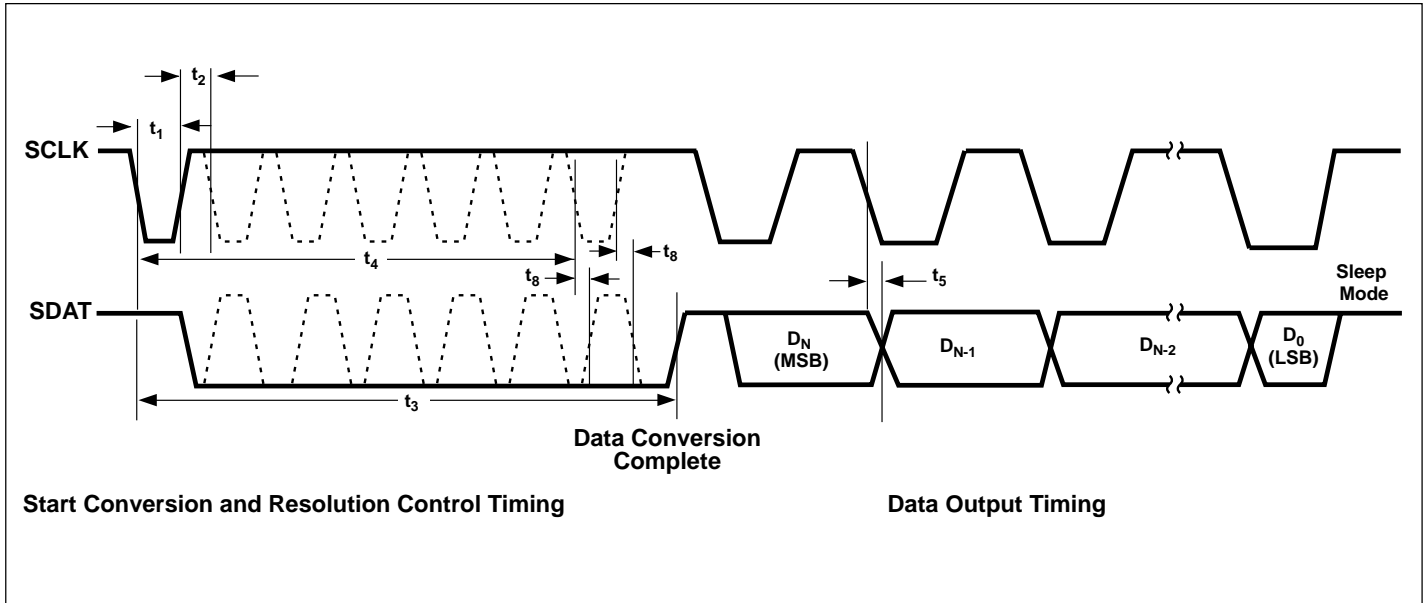

Figure 2. Conversion and Data Output Timing

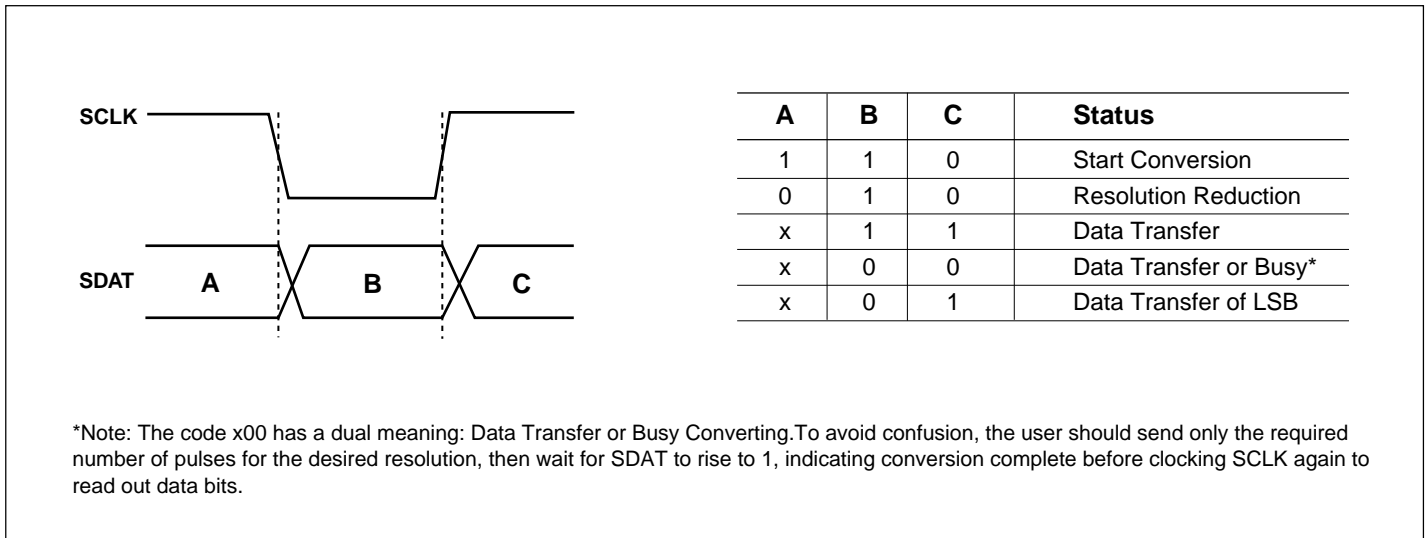

Figure 3. SCLK, SDAT Logic State Table

TC3400

TIMING DIAGRAMS (CONT.)

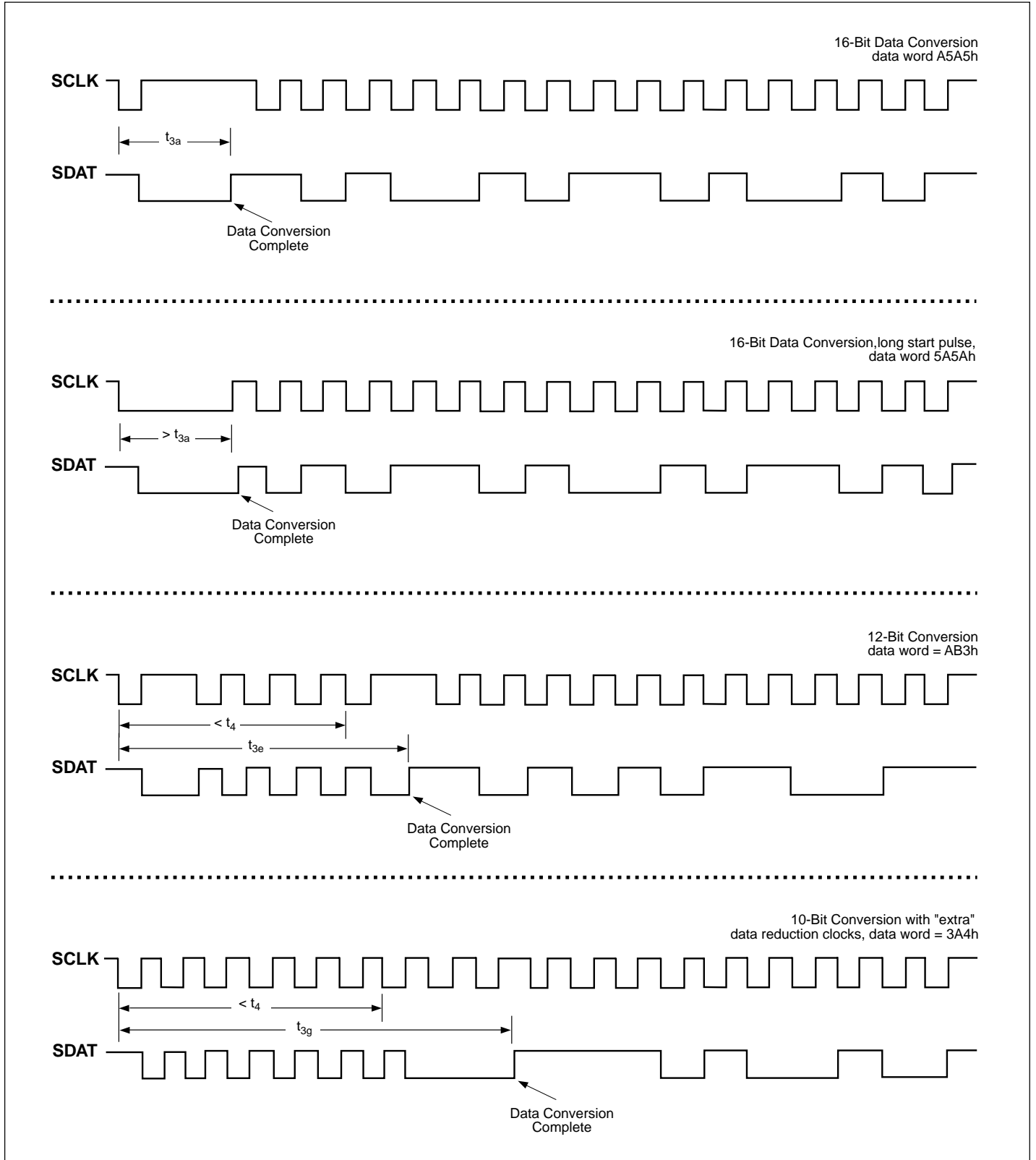
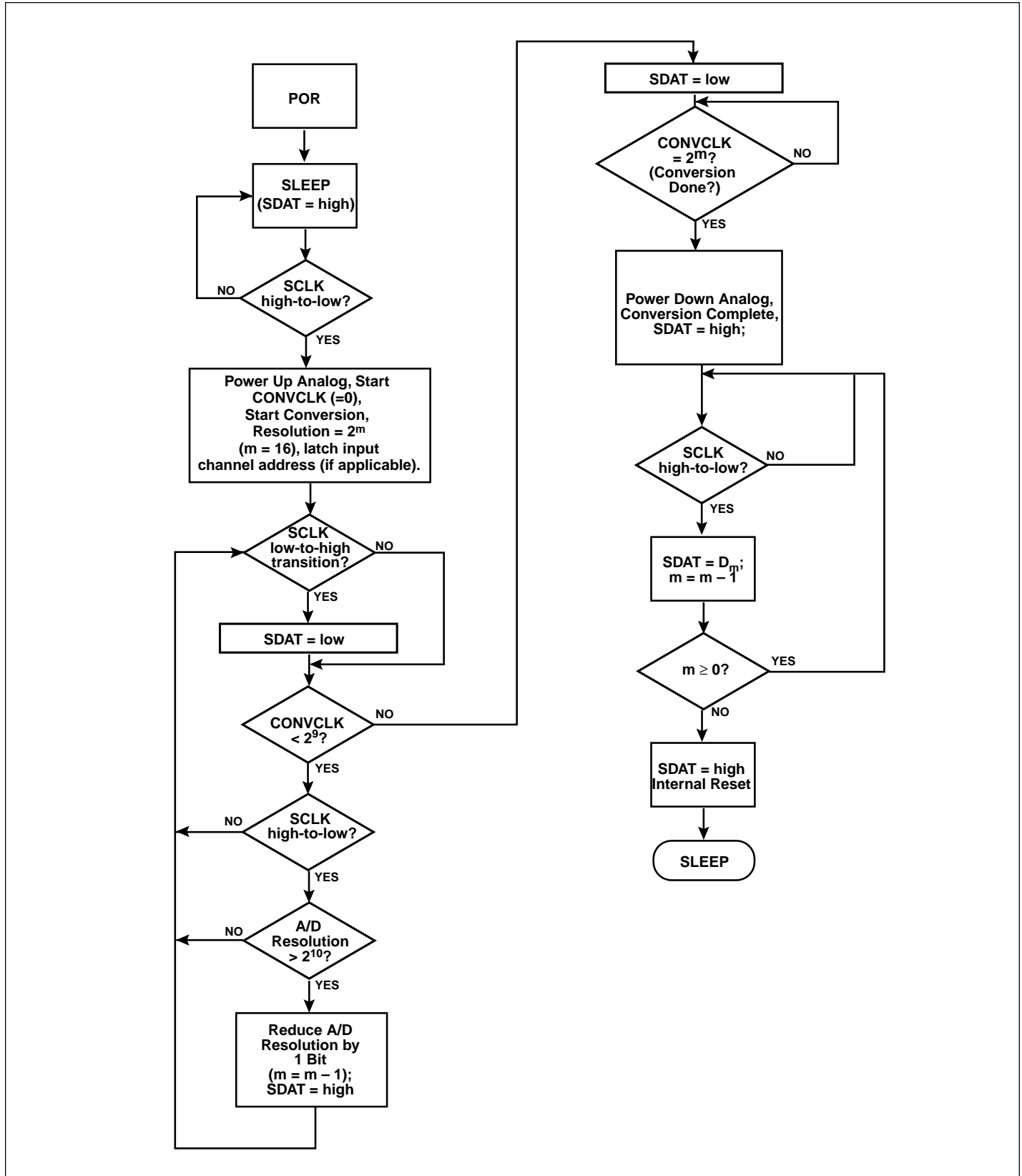

Figure 4. Example Timing Diagrams

A/D OPERATIONAL FLOWCHART



+1.8V, Low Power , 16-Bit Sigma - Delta A/D Converter

TC3400

TAPING FORM

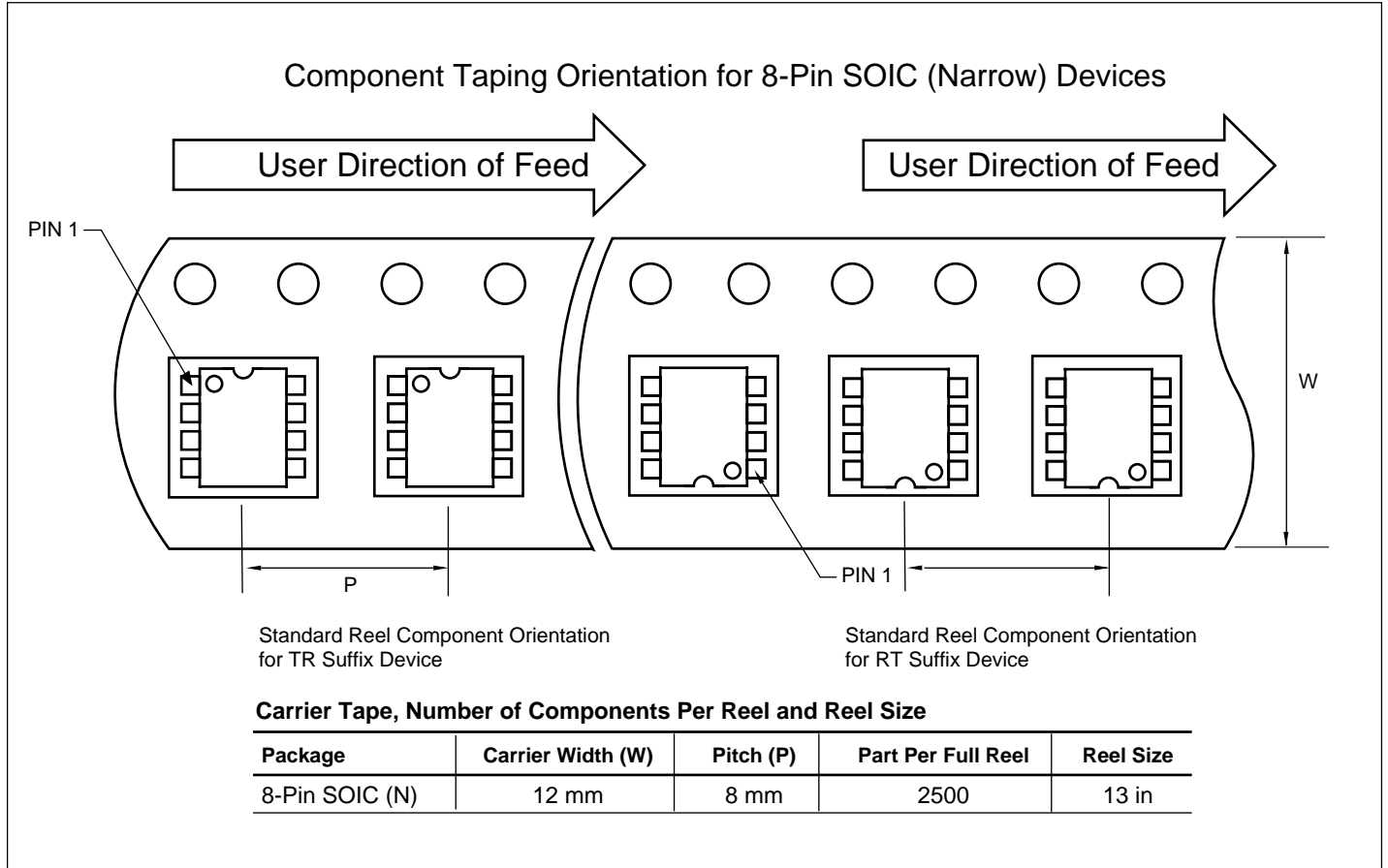

PACKAGE DIMENSIONS

8-Pin PDIP (Narrow)

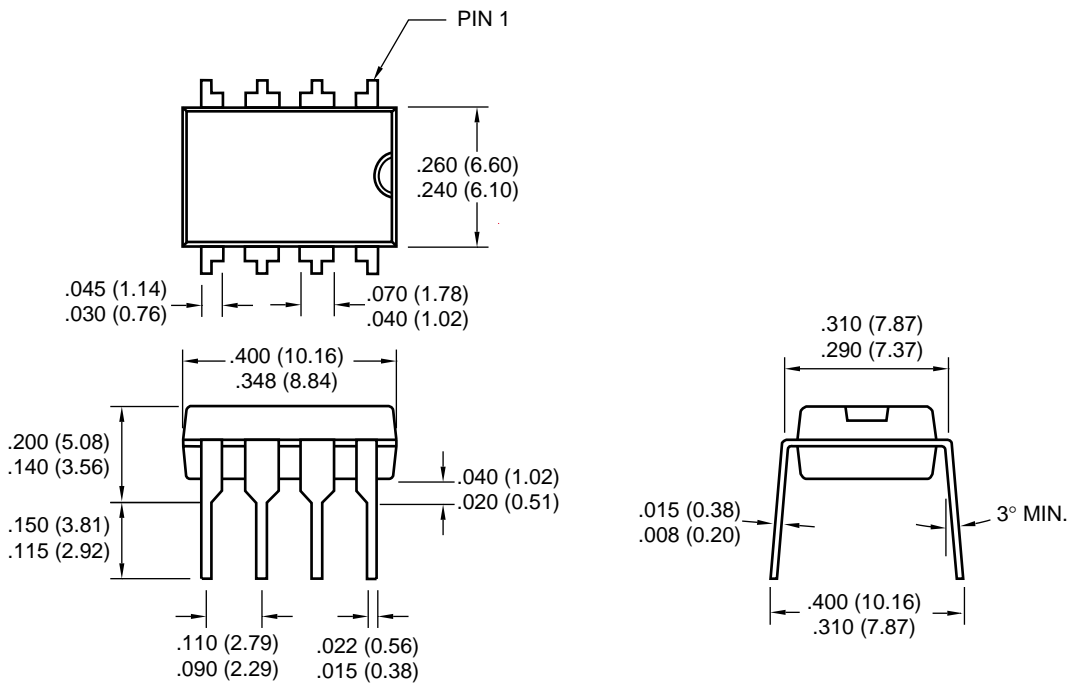

8-Pin SOIC (Narrow)

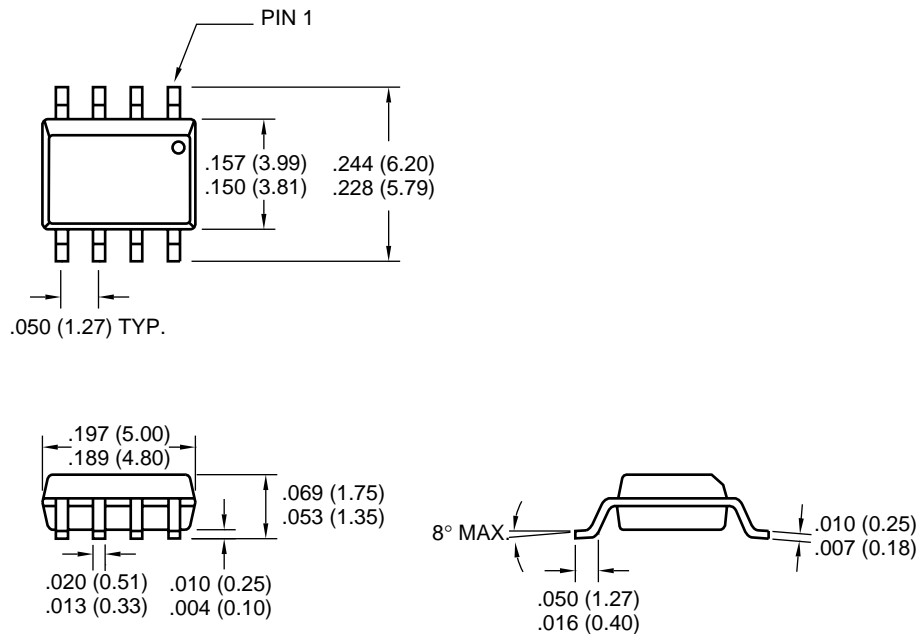

Dimensions: inches(mm)

Trademarks: The Microchip name, logo, PIC, PICmicro, PICMASTER, PICSTART, PRO MATE, KEELOQ, SEEVAL, MPLAB and The Embedded Control Solutions Company are registered trademarks of Microchip Technology Incorporated in the U.S.A. and other countries. Total Endurance, ICSP, In-Circuit Serial Programming, FilterLab, MXDEV, microID, FlexROM, fuzzyLAB, MPASM, MPLINK, MPLIB, PICDEM, ICEPIC, Migratable Memory, FanSense, ECONOMONITOR, Microport and SelectMode are trademarks and SQTP is a service mark of Microchip in the U.S.A.

All other trademarks mentioned herein are the property of their respective companies.



WORLDWIDE SALES AND SERVICE

AMERICAS

Corporate Office

2355 West Chandler Blvd.
Chandler, AZ 85224-6199
Tel: 480-792-7200 Fax: 480-792-7277
Technical Support: 480-792-7627
Web Address: <http://www.microchip.com>

Rocky Mountain

2355 West Chandler Blvd.
Chandler, AZ 85224-6199
Tel: 480-792-7966 Fax: 480-792-7456

Atlanta

500 Sugar Mill Road, Suite 200B
Atlanta, GA 30350
Tel: 770-640-0034 Fax: 770-640-0307

Austin

Analog Product Sales
8303 MoPac Expressway North
Suite A-201
Austin, TX 78759
Tel: 512-345-2030 Fax: 512-345-6085

Boston

2 Lan Drive, Suite 120
Westford, MA 01886
Tel: 978-692-3848 Fax: 978-692-3821

Boston

Analog Product Sales
Unit A-8-1 Millbrook Tarry Condominium
97 Lowell Road
Concord, MA 01742
Tel: 978-371-6400 Fax: 978-371-0050

Chicago

333 Pierce Road, Suite 180
Itasca, IL 60143
Tel: 630-285-0071 Fax: 630-285-0075

Dallas

4570 Westgrove Drive, Suite 160
Addison, TX 75001
Tel: 972-818-7423 Fax: 972-818-2924

Dayton

Two Prestige Place, Suite 130
Miamisburg, OH 45342
Tel: 937-291-1654 Fax: 937-291-9175

Detroit

Tri-Atria Office Building
32255 Northwestern Highway, Suite 190
Farmington Hills, MI 48334
Tel: 248-538-2250 Fax: 248-538-2260

Los Angeles

18201 Von Karman, Suite 1090
Irvine, CA 92612
Tel: 949-263-1888 Fax: 949-263-1338

Mountain View

Analog Product Sales
1300 Terra Bella Avenue
Mountain View, CA 94043-1836
Tel: 650-968-9241 Fax: 650-967-1590

New York

150 Motor Parkway, Suite 202
Hauppauge, NY 11788
Tel: 631-273-5305 Fax: 631-273-5335

San Jose

Microchip Technology Inc.
2107 North First Street, Suite 590
San Jose, CA 95131
Tel: 408-436-7950 Fax: 408-436-7955

Toronto

6285 Northam Drive, Suite 108
Mississauga, Ontario L4V 1X5, Canada
Tel: 905-673-0699 Fax: 905-673-6509

ASIA/PACIFIC

China - Beijing

Microchip Technology Beijing Office
Unit 915
New China Hong Kong Manhattan Bldg.
No. 6 Chaoyangmen Beidajie
Beijing, 100027, No. China
Tel: 86-10-85282100 Fax: 86-10-85282104

China - Shanghai

Microchip Technology Shanghai Office
Room 701, Bldg. B
Far East International Plaza
No. 317 Xian Xia Road
Shanghai, 200051
Tel: 86-21-6275-5700 Fax: 86-21-6275-5060

Hong Kong

Microchip Asia Pacific
RM 2101, Tower 2, Metroplaza
223 Hing Fong Road
Kwai Fong, N.T., Hong Kong
Tel: 852-2401-1200 Fax: 852-2401-3431

India

Microchip Technology Inc.
India Liaison Office
Divyasree Chambers
1 Floor, Wing A (A3/A4)
No. 11, OisShaughnessey Road
Bangalore, 560 025, India
Tel: 91-80-2290061 Fax: 91-80-2290062

Japan

Microchip Technology Intl. Inc.
Benex S-1 6F
3-18-20, Shinyokohama
Kohoku-Ku, Yokohama-shi
Kanagawa, 222-0033, Japan
Tel: 81-45-471-6166 Fax: 81-45-471-6122

Korea

Microchip Technology Korea
168-1, Youngbo Bldg. 3 Floor
Samsung-Dong, Kangnam-Ku
Seoul, Korea
Tel: 82-2-554-7200 Fax: 82-2-558-5934

ASIA/PACIFIC (continued)

Singapore

Microchip Technology Singapore Pte Ltd.
200 Middle Road
#07-02 Prime Centre
Singapore, 188980
Tel: 65-334-8870 Fax: 65-334-8850

Taiwan

Microchip Technology Taiwan
11F-3, No. 207
Tung Hua North Road
Taipei, 105, Taiwan
Tel: 886-2-2717-7175 Fax: 886-2-2545-0139

EUROPE

Australia

Microchip Technology Australia Pty Ltd
Suite 22, 41 Rawson Street
Epping 2121, NSW
Australia
Tel: 61-2-9868-6733 Fax: 61-2-9868-6755

Denmark

Microchip Technology Denmark ApS
Regus Business Centre
Lautrup hoj 1-3
Ballerup DK-2750 Denmark
Tel: 45 4420 9895 Fax: 45 4420 9910

France

Arizona Microchip Technology SARM
Parc d'Activite du Moulin de Massy
43 Rue du Saule Trapu
Batiment A - 1er Etage
91300 Massy, France
Tel: 33-1-69-53-63-20 Fax: 33-1-69-30-90-79

Germany

Arizona Microchip Technology GmbH
Gustav-Heinemann Ring 125
D-81739 Munich, Germany
Tel: 49-89-627-144 0 Fax: 49-89-627-144-44

Germany

Analog Product Sales
Lochhamer Strasse 13
D-82152 Martinsried, Germany
Tel: 49-89-895650-0 Fax: 49-89-895650-22

Italy

Arizona Microchip Technology SRL
Centro Direzionale Colleoni
Palazzo Taurus 1 V. Le Colleoni 1
20041 Agrate Brianza
Milan, Italy
Tel: 39-039-65791-1 Fax: 39-039-6899883

United Kingdom

Arizona Microchip Technology Ltd.
505 Eskdale Road
Winnersh Triangle
Wokingham
Berkshire, England RG41 5TU
Tel: 44 118 921 5869 Fax: 44-118 921-5820

All rights reserved. © 2001 Microchip Technology Incorporated. Printed in the USA. 1/01  Printed on recycled paper.

01/09/01

Information contained in this publication regarding device applications and the like is intended through suggestion only and may be superseded by updates. It is your responsibility to ensure that your application meets with your specifications. No representation or warranty is given and no liability is assumed by Microchip Technology Incorporated with respect to the accuracy or use of such information, or infringement of patents or other intellectual property rights arising from such use or otherwise. Use of Microchip's products as critical components in life support systems is not authorized except with express written approval by Microchip. No licenses are conveyed, implicitly or otherwise, except as maybe explicitly expressed herein, under any intellectual property rights. The Microchip logo and name are registered trademarks of Microchip Technology Inc. in the U.S.A. and other countries. All rights reserved. All other trademarks mentioned herein are the property of their respective companies.