

INTRODUCTION:

Adam Tech RG1 relays are small size general purpose relays available in four different contact formats with either AC or DC activated coils. These relays are available with PCB, Solder, or Quick Connect terminals and a Flange Mount cover option. Rated up to 15 amps, they are ideal for applications such as industrial control equipment, office machines, and medical equipment.

FEATURES:

Contact ratings up to 15 amps
AC and DC coils available
Top mount flange option

SPECIFICATIONS:

Electrical:

Contact arrangements: 1 Form A & 1 Form C / 2 Form A & 2 Form C
Contact material: Silver Alloy
Contact Rating (Resistive load): 15A @ 250V AC
15A @ 30V DC
Max. Switching Voltage: 250V AC / 30V DC
Max. Switching Power: 3750VA / 450W
Contact resistance: 50 mΩ max. Initial
Insulation resistance: 500 MΩ min. @ 500V DC
Dielectric withstanding voltage:
Between Coil & Contact: 2500V AC 50/60Hz for 1 min.
Between Contacts: 1500V AC 50/60Hz for 1 min.
Operating time: 25 ms max.
Release time: 25 ms max.
Electrical Life: 100,000 Operations (at rated load)

Mechanical:

Vibration resistance (Endurance): 1.0mm double amplitude 10-55Hz
Shock resistance: 10G min.
Mechanical Life: 10,000,000 Operations (no load)

Temperature Rating:

Ambient temperature: -45°C to +85°C

PACKAGING:

Anti-ESD plastic trays

SAFETY AGENCY APPROVALS:

UL Recognized & CSA Certified, File no. E305638



RG1-2C-QC-110VAC-F



RG1-2C-QC-110VAC

**ORDERING INFORMATION
GENERAL PURPOSE RELAY**

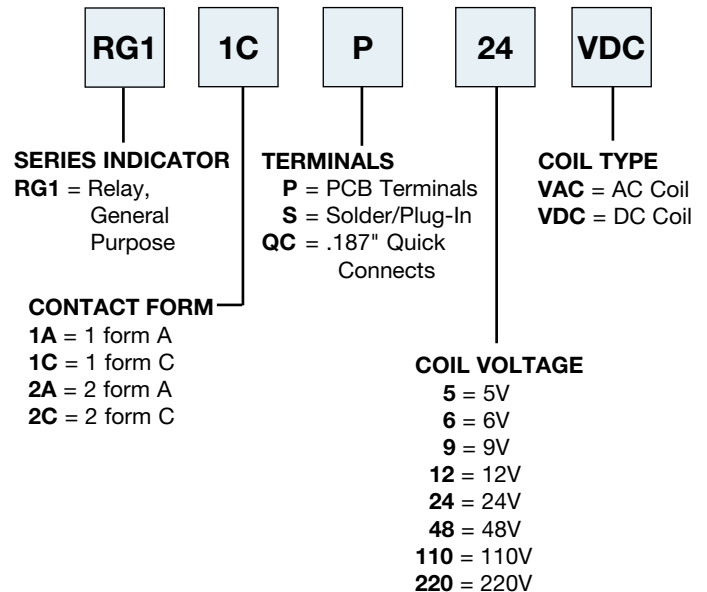

OPTION:

Add designator(s) to end of part number
F = Top Mount flange



RG1 SERIES

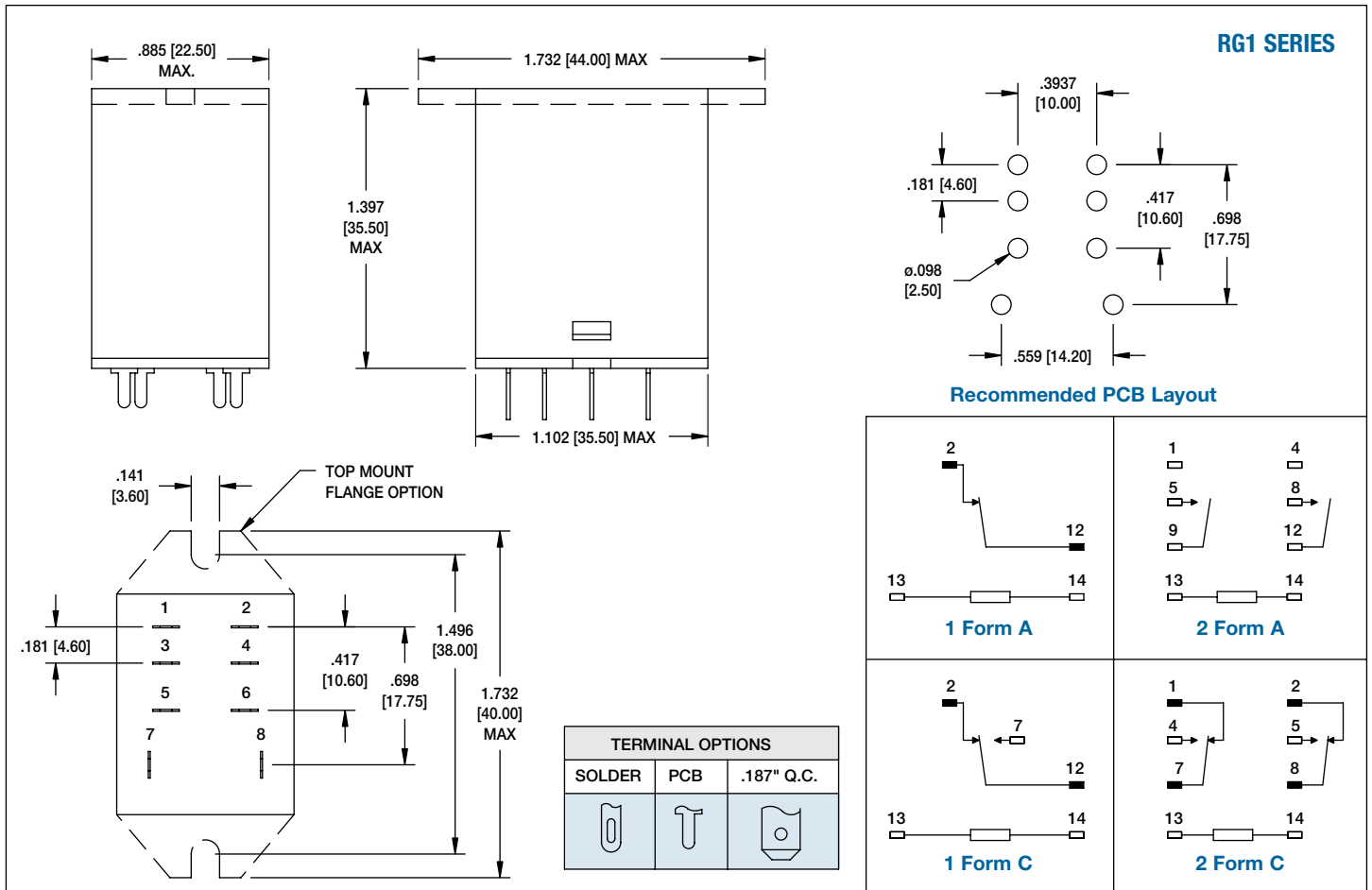

DC Types @ 20° C

Nominal Voltage V DC	Pick-up Voltage V DC (max.)	Drop-out Voltage V DC (min.)	Nominal Operating Current mA (±10%)	Coil Resistance (±10%)	Operating Power W		Max allowable Voltage V DC
					Nominal	Minimum	
6	4.8	0.6	150	40	0.9	0.58	6.6
12	9.6	1.2	75	160	0.9	0.58	13.2
24	19.2	2.4	37	640	0.9	0.58	26.4
48	38.4	4.8	18.5	2,560	0.9	0.58	52.8
110/120	88	11	10	13,400	0.9	0.58	121

AC Types (50/60 Hz) @ 60 Hz, 20° C

Nominal Voltage V AC	Pick-up Voltage V DC (max.)	Drop-out Voltage V DC (min.)	Nominal Operating Current mA (±10%)	Coil Resistance (±10%)	Operating Power VA	Max allowable Voltage V DC
6	4.8	1.2	220	10	Nominal 1.20 Minimum 0.77	6.6
12	9.6	2.4	110	40		13.2
24	19.2	4.8	60	160	Minimum 0.77	26.4
48	38.4	9.6	30	650		52.8
110/120	88	22	13.5 / 14.5	3,400		132
220/240	176	44	6.0 / 6.5	1,360		264