

VHF/ UHF-Tuner-IC

Description

This tuner IC requires a power supply of 9 V and performs the function of two separate oscillators and mixers, SAWF-driver and dual-sate band switch. Applications are 9 V TV-and VCR-tuners.

Features

- 9 V supply voltage
- Frequency range from 48 to 860 MHz
- Band A: balanced high impedance mixer input and amplitude controlled oscillator
- Band B: balanced low impedance mixer input and symmetrical oscillator
- SAW filter driver with low impedance output
- Voltage regulator for stable operating characteristics
- ESD protection on all pins except oscillator pins and RF-inputs

Benefits

- The small SO20 package allows to develop small and economic 2-band tuners

Block Diagram

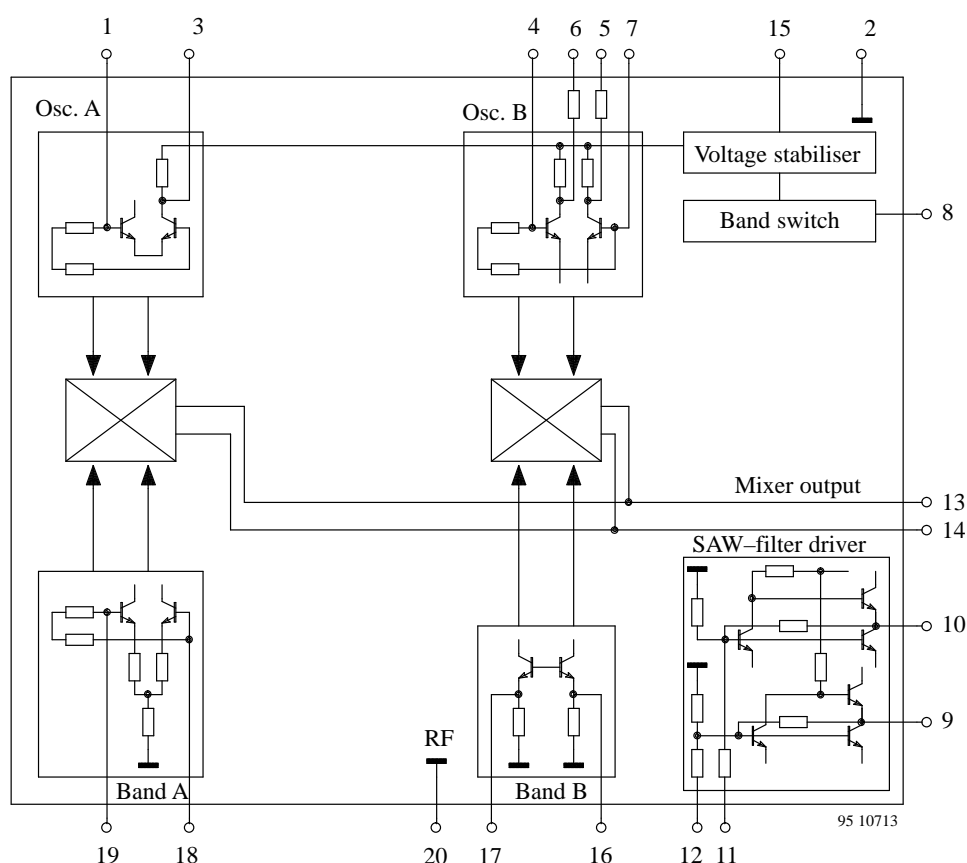
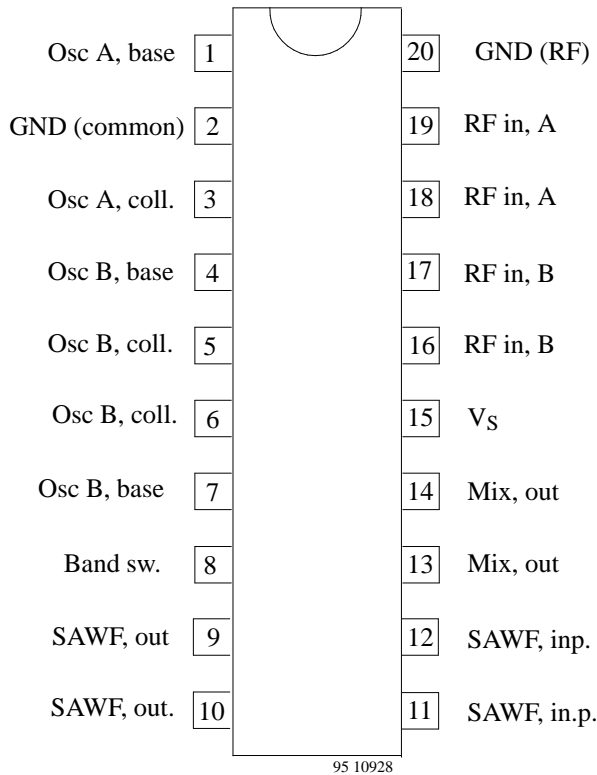

Figure 1. Block diagram

Pin Configuration



Pin	Symbol	Function
1	Osc A, base	Oscillator band A, base
2	GND (common)	Ground, common
3	Osc A, coll.	Oscillator band A, collector
4, 7	Osc B, base	Oscillator band B, bases
5, 6	Osc B, coll.	Oscillator band B, collectors
8	Band sw.	Dual-state band switch
9, 10	SAWF, out	SAW filter driver outputs
11, 12	SAWF, inp.	SAW filter driver input
13, 14	Mix, out	Mixer outputs, open collector
15	V _S	Supply voltage V _S
16, 17	RF in, B	RF inputs, band B
18, 19	RF in, A	RF inputs, band A
20	GND (RF)	Ground, RF part

Ordering Information

Extended Type Number	Package	Remarks
U2329B-FLG3	SO20	Taped and reeled

Absolute Maximum Ratings

All voltages are referred to GND, Pin 2

Parameters	Symbol	Min.	Typ.	Max.	Unit
Supply voltage	V _S			10.5	V
RF inputs				5.0	V
IF outputs				10.5	V
Dual-state switch voltage	V _{iDSW}			10.5	V
Junction temperature	T _{jmax}			125	°C
Storage temperature	T _{stg}	-40		125	°C

Operating Range

All voltages are referred to GND, Pin 2

Parameters	Test Conditions / Pins	Symbol	Min	Typ	Max	Unit
Supply voltage	Pin 13-15	V _S	8.1	9	9.9	V
Ambient temperature		T _{amb}	-25		75	°C
Thermal resistance	Test conditions page 4	R _{thJA}		90		K/W

Electrical Characteristics

Test conditions (unless otherwise specified): $V_s = 9\text{ V}$. $T_{\text{amb}} = 25\text{ °C}$. Reference point Pin 2

Parameters	Test Conditions / Pins	Symbol	Min	Typ	Max	Unit
Supply voltage	Pin 13-15	V_S	8.1	9.0	9.9	V
Supply current	Pin 13-15	I_S		42		mA
Band switch						
Voltage band A	Pin 8	VSWA	0	0	1.0	V
Voltage band B	Pin 8	VSWB	3.4	4.0	5.0	V
Switching current	VSW = 5 V Pin 8	ISW			100	μA
SAW filter driver $f_i = 36\text{ MHz}$						
Input impedance	Pin 11, 12	$Z_{i\text{SAW}}$		450		Ω
Output impedance	Pin 9, 10	$Z_{o\text{SAW}}$		70		
Voltage gain	11, 12 \rightarrow Pin 9, 10	$G_{v\text{SAW}}$		17		dB
Band A (note 1)						
Input frequency range	Pin 18	f_{iA}	48		470	MHz
Input impedance	Pin 18	S_{11A}		see Fig. 3		
Gain (note 4)	Pin I/P to O/P	GA		28		dB
Noise figure DSB (note 2):	Pin I/P to O/P $f_{iA} = 50\text{ MHz}$ $f_{iA} = 150\text{ MHz}$	NF NF		11.5 12		dB dB
Input level for (note 3):	Each carrier					
IM3 (interm. of 3rd order)	$f_{iA} = 71\text{ MHz}$ Pin I/P	V_{iA}		-23		dBm
IM2 (interm. of 2nd order)	$f_{iA} = 71\text{ MHz}$ Pin I/P	V_{iA}		-22		dBm
Band B (note 1)						
Input frequency range	Pin 16, 17	f_{iB}	470		860	MHz
Input impedance	Figure 3 Pin 16, 17	S_{11B}			8	
Gain (note 4)	Pin I/P to O/P	GB		32		dB
Noise figure DSB (note 2)	Pin I/P to O/P $f_{iB} = 500\text{ MHz}$ $f_{iB} = 800\text{ MHz}$	NF NF		10.5 11.5		dB dB
Input level for IM3 (interm. of 3rd order, note 3)	Each carrier $f_{iB} = 600\text{ MHz}$ Pin I/P	V_{iB}		-25		dBm

Notes

- 1) The RF input B is symmetrical driven by means of a hybrid for 180° phase shifting, consequently the source impedance is 100 Ω . All other impedance for RF tests is 50 Ω .
- 2) The noise figure (NF) is the value for double-side-band measurement.
- 3) The intermodulation test (2-carrier-method) which is made on IF-center is in reference to a signal-to-IM ratio of 60 dB.
- 4) Gain is the ratio of the voltage at the primary coil of L5 to the available voltage at the input.

Input Impedance Mixer Band A (S11A) and B (S11B)

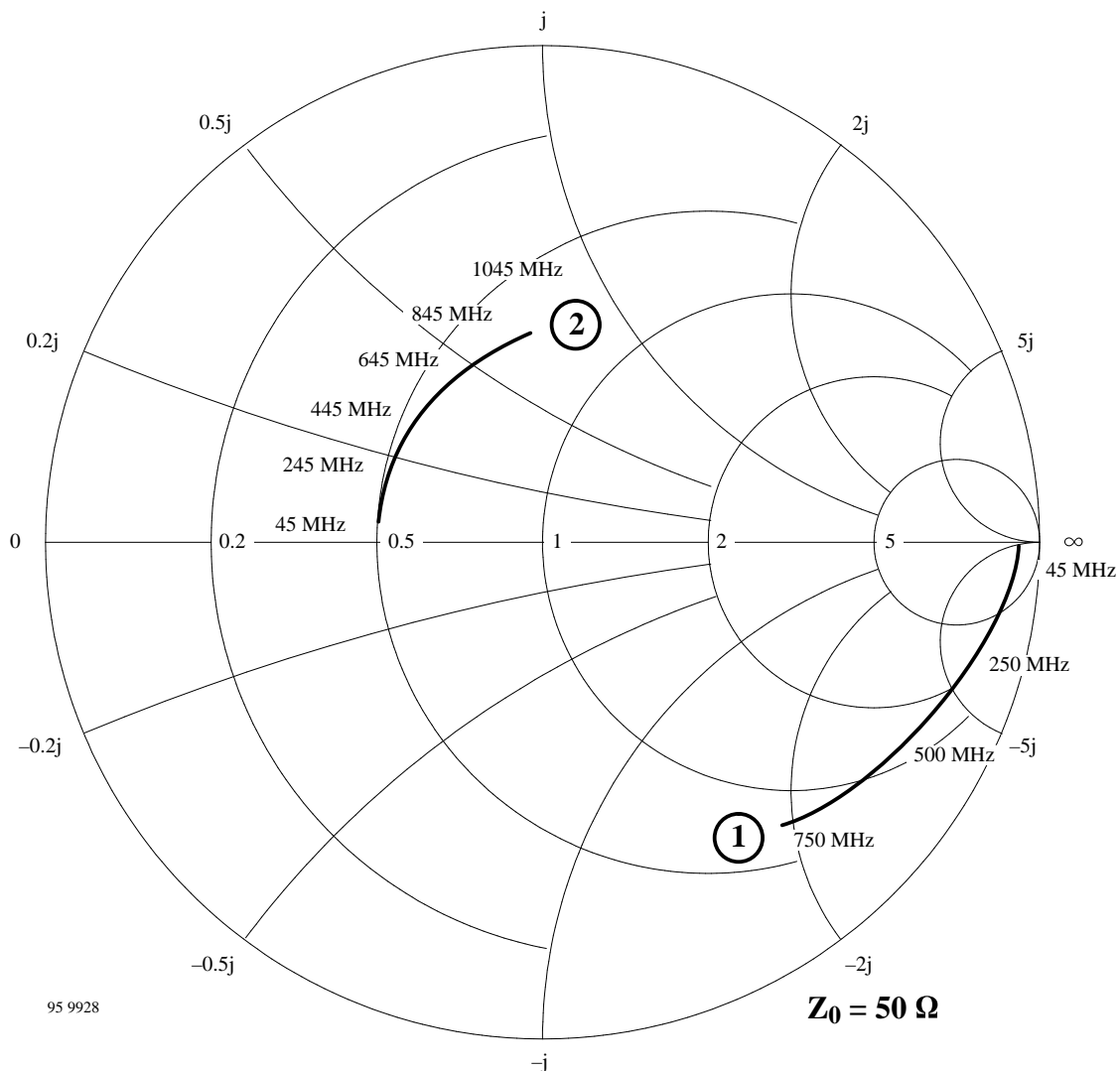
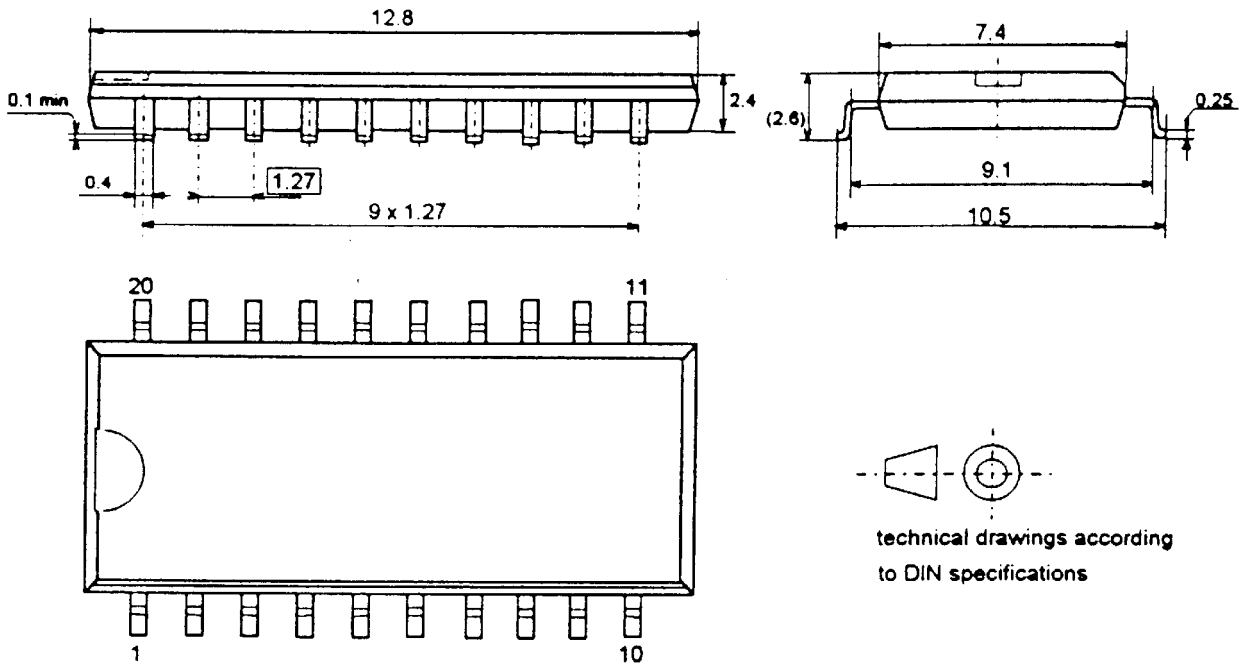

Figure 4. Input impedance mixer band A (S11A) and B (S11B)

- 1) **VHF-Low**
Normalised to 50Ω , measuring range 45 MHz to 750 MHz.
- 2) **VHF-High and UHF**
Normalised to 50Ω , measuring range 45 MHz to 1045 MHz. Input is driven symmetrical. The output impedance of hybrid is 100Ω , the measured level is then calculated in reference to 50Ω .

Dimensions in mm:

Package: SO20



95 10712

Ozone Depleting Substances Policy Statement

It is the policy of **TEMIC TELEFUNKEN microelectronic GmbH** to

1. Meet all present and future national and international statutory requirements.
2. Regularly and continuously improve the performance of our products, processes, distribution and operating systems with respect to their impact on the health and safety of our employees and the public, as well as their impact on the environment.

It is particular concern to control or eliminate releases of those substances into the atmosphere which are known as ozone depleting substances (ODSs).

The Montreal Protocol (1987) and its London Amendments (1990) intend to severely restrict the use of ODSs and forbid their use within the next ten years. Various national and international initiatives are pressing for an earlier ban on these substances.

TEMIC TELEFUNKEN microelectronic GmbH semiconductor division has been able to use its policy of continuous improvements to eliminate the use of ODSs listed in the following documents.

1. Annex A, B and list of transitional substances of the Montreal Protocol and the London Amendments respectively
2. Class I and II ozone depleting substances in the Clean Air Act Amendments of 1990 by the Environmental Protection Agency (EPA) in the USA
3. Council Decision 88/540/EEC and 91/690/EEC Annex A, B and C (transitional substances) respectively.

TEMIC can certify that our semiconductors are not manufactured with ozone depleting substances and do not contain such substances.

We reserve the right to make changes to improve technical design and may do so without further notice.

Parameters can vary in different applications. All operating parameters must be validated for each customer application by the customer. Should the buyer use TEMIC products for any unintended or unauthorized application, the buyer shall indemnify TEMIC against all claims, costs, damages, and expenses, arising out of, directly or indirectly, any claim of personal damage, injury or death associated with such unintended or unauthorized use.

TEMIC TELEFUNKEN microelectronic GmbH, P.O.B. 3535, D-74025 Heilbronn, Germany
Telephone: 49 (0)7131 67 2831, Fax number: 49 (0)7131 67 2423