EM78F562N/F662N

**8-Bit
Microcontroller**

**Product
Specification**

DOC. VERSION 1.3

ELAN MICROELECTRONICS CORP.

April 2016



Trademark Acknowledgments:

IBM is a registered trademark and PS/2 is a trademark of IBM.

Windows is a trademark of Microsoft Corporation.

ELAN and ELAN logo  are trademarks of ELAN Microelectronics Corporation.

Copyright © 2016 by ELAN Microelectronics Corporation

All Rights Reserved

Printed in Taiwan

The contents of this specification are subject to change without further notice. ELAN Microelectronics assumes no responsibility concerning the accuracy, adequacy, or completeness of this specification. ELAN Microelectronics makes no commitment to update, or to keep current the information and material contained in this specification. Such information and material may change to conform to each confirmed order.

In no event shall ELAN Microelectronics be made responsible for any claims attributed to errors, omissions, or other inaccuracies in the information or material contained in this specification. ELAN Microelectronics shall not be liable for direct, indirect, special incidental, or consequential damages arising from the use of such information or material.

The software (if any) described in this specification is furnished under a license or nondisclosure agreement, and may be used or copied only in accordance with the terms of such agreement.

ELAN Microelectronics products are not intended for use in life support appliances, devices, or systems. Use of ELAN Microelectronics product in such applications is not supported and is prohibited.

NO PART OF THIS SPECIFICATION MAY BE REPRODUCED OR TRANSMITTED IN ANY FORM OR BY ANY MEANS WITHOUT THE EXPRESSED WRITTEN PERMISSION OF ELAN MICROELECTRONICS.



ELAN MICROELECTRONICS CORPORATION

Headquarters:

No. 12, Innovation Road 1
Hsinchu Science Park
Hsinchu, TAIWAN 308
Tel: +886 3 563-9977
Fax: +886 3 563-9966
webmaster@emc.com.tw
<http://www.emc.com.tw>

Hong Kong:

Elan (HK) Microelectronics Corporation, Ltd.
Flat A, 19F., World Tech Centre
95 How Ming Street, Kwun Tong
Kowloon, HONG KONG
Tel: +852 2723-3376
Fax: +852 2723-7780

USA:

Elan Information Technology Group (U.S.A.)
PO Box 601
Cupertino, CA 95015
U.S.A.
Tel: +1 408 366-8225
Fax: +1 408 366-8225

Shenzhen:

Elan Microelectronics Shenzhen, Ltd.
8A Floor, Microprofit Building
Gaoxin South Road 6
Shenzhen Hi-Tech Industrial Park
South Area, Shenzhen
CHINA 518057
Tel: +86 755 2601-0565
Fax: +86 755 2601-0500
elan-sz@elanic.com.cn

Shanghai:

Elan Microelectronics Shanghai, Ltd.
6F, Ke Yuan Building
No. 5 Bibo Road
Zhangjiang Hi-Tech Park
Shanghai, CHINA 201203
Tel: +86 21 5080-3866
Fax: +86 21 5080-0273
elan-sh@elanic.com.cn

Contents

1	General Description	1
2	Features	1
3	Pin Assignment	2
4	Pin Description	4
4.1	EM78F562N/F662N	4
5	Block Diagram	6
6	Functional Description	7
6.1	Operational Registers	7
6.1.1	R0 (Indirect Addressing Register)	7
6.1.2	R1 (Timer Clock/Counter)	7
6.1.3	R2 (Program Counter) and Stack	7
6.1.4	R3 (Status Register)	10
6.1.5	R4 (RAM Select Register)	10
6.1.6	Bank 0 R5 ~ R8 (Port 5 ~ Port 8)	10
6.1.7	Bank 0 R9 TBPTL (Low Byte of Table Pointer Register)	10
6.1.8	Bank 0 RA (Wake-up Control Register)	10
6.1.9	Bank 0 RB (EEPROM Control Register)	11
6.1.10	Bank 0 RC (128 Bytes EEPROM Address)	12
6.1.11	Bank 0 RD (128 Bytes EEPROM Data)	12
6.1.12	Bank 0 RE (CPU Operating Control Register)	12
6.1.13	Bank 0 RF (Interrupt Status Register)	13
6.1.14	R10 ~ R3F	14
6.1.15	Bank 1 R5 ~R7	14
6.1.16	Bank 1 R8 TC2CR (Timer 2 Control)	14
6.1.17	Bank 1 R9 TC2DH (Timer 2 High Byte Data Buffer)	17
6.1.18	Bank 1 RA TC2DL (Timer 2 Low Byte Data Buffer)	17
6.1.19	Bank 1 RB ~RE	17
6.1.20	Bank 1 RF (Interrupt Status Register)	17
6.1.21	Bank 2 R5 AISR (ADC Input Select Register)	18
6.1.22	Bank 2 R6 ADCON (A/D Control Register)	19
6.1.23	Bank 2 R7 ADOC (A/D Offset Calibration Register)	20
6.1.24	Bank 2 R8 ADDH (AD High 8-Bit Data Buffer)	20
6.1.25	Bank 2 R9 ADDL (AD Low 2-Bit Data Buffer)	20
6.1.26	Bank 2 RA, RC ~ RE	20
6.1.27	Bank 2 RB CMPCON (Comparator Control Register)	21
6.1.28	Bank 2 RF (Pull-high Control Register 1)	22
6.1.29	Bank 3 R5	22
6.1.30	Bank 3 R6 TBPTH (High Byte of Table Pointer Register)	22
6.1.31	Bank 3 R7~RC	22
6.1.32	Bank 3 RD TC3CR (Timer 3 Control)	22
6.1.33	Bank 3 RE TC3D (Timer 3 Data Buffer)	25
6.1.34	Bank 3 RF (Pull-down Control Register 1)	25
6.2	Special Function Registers	25
6.2.1	A (Accumulator)	25
6.2.2	CONT (Control Register)	25
6.2.3	IOC5 ~ IOC8 (I/O Port Control Register)	26
6.2.4	IOC9	26

6.2.5	IOCA (WDT Control Register).....	26
6.2.6	IOCB (Pull-down Control Register 2).....	27
6.2.7	IOCC (Open-drain Control Register).....	28
6.2.8	IOCD (Pull-high Control Register 2).....	28
6.2.9	IOCE (Interrupt Mask Register 2).....	28
6.2.10	IOCF (Interrupt Mask Register 1).....	29
6.3	TCC/WDT and Prescaler.....	30
6.4	I/O Ports.....	31
6.5	Reset and Wake-up.....	34
6.5.1	Reset.....	34
6.5.2	Wake-up.....	37
6.5.3	Summary of Register Initial Values after Reset.....	38
6.5.4	Status of RST, T, and P of the Status Register.....	42
6.6	Interrupt.....	43
6.7	Data EEPROM (only for EM78F662N).....	45
6.7.1	Data EEPROM Control Register.....	45
6.7.1.1	RB (EEPROM Control Register).....	45
6.7.1.2	RC (128 Bytes EEPROM Address).....	46
6.7.1.3	RD (256 Bytes EEPROM Data).....	46
6.7.2	Programming Step / Example Demonstration.....	46
6.7.2.1	Programming Step.....	46
6.7.2.2	Example Demonstration Programs.....	46
6.8	Analog-to-Digital Converter (ADC).....	47
6.8.1	ADC Control Register (AISR/R5, ADCON/R6, ADOC/R7).....	48
6.8.1.1	Bank 2 R5 AISR (ADC Input Select Register).....	48
6.8.1.2	Bank 2 R6 ADCON (A/D Control Register).....	49
6.8.1.3	Bank 2 R7 ADOC (A/D Offset Calibration Register).....	50
6.8.2	ADC Data Buffer (ADDH, ADDL/R8, R9).....	50
6.8.3	A/D Sampling Time.....	50
6.8.4	A/D Conversion Time.....	51
6.8.5	A/D Operation during Sleep Mode.....	51
6.8.6	Programming Steps/Considerations.....	52
6.8.6.1	Programming Steps.....	52
6.8.6.2	Demonstration Programs.....	52
6.9	Timer/Counter 2.....	54
6.10	Timer/Counter 3.....	56
6.11	Comparator.....	57
6.11.1	Comparator Outputs.....	58
6.11.2	Comparator Interrupt.....	58
6.11.3	Wake-up from Sleep Mode.....	58
6.12	Oscillator.....	59
6.12.1	Oscillator Modes.....	59
6.12.2	Crystal Oscillator/Ceramic Resonators (Crystal).....	60
6.12.3	External RC Oscillator Mode.....	61
6.12.4	Internal RC Oscillator Mode.....	63
6.13	Code Option Register.....	63
6.13.1	Code Option Register (Word 0).....	63
6.13.2	Code Option Register (Word 1).....	64
6.13.3	Customer ID Register (Word 2).....	65
6.14	Power-on Considerations.....	66
6.15	External Power-on Reset Circuit.....	66
6.16	Residue-Voltage Protection.....	67
6.17	Instruction Set.....	68

7	Timing Diagrams	71
8	Absolute Maximum Ratings.....	72
9	DC Electrical Characteristics.....	72
9.1	Data EEPROM Electrical Characteristics	73
9.2	Program Flash Memory Electrical Characteristics	74
9.3	A/D Converter Characteristics.....	74
9.4	Comparator Characteristics	75
10	AC Electrical Characteristics.....	75

APPENDIX

A	Ordering and Manufacturing Information	76
B	Package Type.....	77
C	Package Information	78
C.1	EM78F562N/F662ND16 300mil	78
C.2	EM78F562N/F662NSO16 300mil	79
C.3	EM78F662NQN16A 4x4mm.....	80
C.4	EM78F662NSS16 150mil	81
C.5	EM78F562N/F662ND18 300mil	82
C.6	EM78F562N/F662NSO18 300mil	83
C.7	EM78F562N/F662ND20 300mil	84
C.8	EM78F562/F662NSO20 300mil	85
D	Quality Assurance and Reliability	86
D.1	Address Trap Detect	86

Specification Revision History

Doc. Version	Revision Description	Date
1.0	Initial release version	2010/04/29
1.1	<ol style="list-style-type: none">1. Modified the ICC1 and ICC2 current2. Deleted the QFN16 package of EM78F562N.3. Modified the EM78F662NQN16 to EM78F662NQN16A.4. Fixed the Code Option Word 2 Bit 7 to "1"	2012/06/29
1.2	<ol style="list-style-type: none">1. Added LVR characteristics in the DC Electrical Characteristics section.2. Added SSOP package for EM78F662N.	2013/05/29
1.3	<ol style="list-style-type: none">1. Added power consumption for EEPROM2. Modified the EEPROM Endurance cycle from 100K to 1000K.3. Added Appendix A for Ordering and Manufacturing Information	2016/04/07



1 General Description

The EM78F562N/F662N devices are 8-bit microprocessors designed and developed with low-power, high-speed CMOS technology and high noise immunity. They have an on-chip 2K×13-bit Electrical Flash Memory and EM78F662N has 128×8-bit in system programmable EEPROM. It provides three protection bits to prevent intrusion of user's Flash memory code. Twelve Code option bits are also available to meet user's requirements.

With its enhanced Flash-ROM features, the EM78F562N/F662N provides a convenient way of developing and verifying user's programs. Moreover, this Flash-ROM device offers the advantage of easy and effective program updates, using development and programming tools. User can avail of the ELAN Writer to easily program his development code.

2 Features

- CPU configuration
 - 2K×13 bits Flash memory
 - 144×8 bits on chip registers (SRAM)
 - 128 bytes in-system programmable EEPROM(Only for EM78F662N)
*Endurance: 100,000 write/erase cycles
 - More than 10 years data retention
 - 8-level stacks for subroutine nesting
 - Less than 2 mA at 5V/4 MHz
 - Typically 20 μ A, at 3V/32kHz
 - Typically 2 μ A, during sleep mode
- I/O port configuration
 - Three bidirectional I/O ports
 - Wake-up port : P6
 - High sink port : P6
 - 12 Programmable pull-down I/O pins
 - Eight programmable pull-high I/O pins
 - Four programmable open-drain I/O pins
 - External interrupt : P60
- Operating voltage range:
 - Industrial: 2.4V~5.5V at -40°C ~85°C
 - Commercial: 2.2V~5.5V at 0°C ~70°C
- Operating frequency range (base on two clocks):
 - Crystal mode:
 - DC ~ 20 MHz @ 5V
 - DC ~ 8 MHz @ 3V
 - DC ~ 4 MHz @ 2.2V
 - ERC mode:
 - DC ~ 20 MHz @ 5V
 - DC ~ 8 MHz @ 3V
 - DC ~ 4 MHz @ 2.2V
 - IRC Drift Rate (Ta=25°C, VDD=5V \pm 5%, VSS=0V)
- One 16-bit Timer/Counter
 - TC2 : Timer/Counter/Window
- One 8-bit Timer/Counter
 - TC3 : Timer/Counter/PDO (Programmable Divider Output) / PWM (pulse width modulation)
- Comparator (CMP)
- Seven available interrupts:
 - Internal interrupt: 4
 - External interrupt: 3
- 8 channels Analog-to-Digital Converter with 10-bit resolution
- Peripheral configuration
 - 8-bit real timer clock/counter (TCC) with selective signal sources, trigger edges, and overflow interrupt
 - Power down (Sleep) mode
 - Four programmable Level Voltage Reset (LVR)
LVR : 4.0V, 3.5V, 2.7V, and POR
 - Three security registers to prevent intrusion of Flash memory codes
 - One configuration register to accommodate user's requirements
 - 2-/4-/8-/16 clocks per instruction cycle selected by code option
 - High EFT immunity
 - Two sub-frequency, 128kHz and 16kHz, the 16kHz is provided by dividing 128kHz
- Single instruction cycle commands
- Four Crystal range in Oscillator Mode

Crystal Range	Oscillator Mode
20 MHz ~ 6 MHz	HXT
6 MHz ~ 1 MHz	XT
1 MHz ~ 100kHz	LXT1
32.768kHz	LXT2

- Programmable free running Watchdog Timer
- Package Type:
 - 16-pin DIP 300mil : EM78F562N/F662ND16
 - 16-pin SOP 300mil : EM78F562N/F662NSO16
 - 16-pin QFN 4x4mm : EM78F662NQN16A
 - 16-pin SSOP 150 mil: EM78F662NSS16
 - 18-pin DIP 300mil : EM78F562N/F662ND18
 - 18-pin SOP 300mil : EM78F562N/F662NSO18
 - 20-pin DIP 300 mil : EM78F562N/F662ND20
 - 20-pin SOP 300mil : EM78F562N/F662NSO20

Note: These are all Green products which do not contain hazardous substances.

Internal RC Frequency	Drift Rate			
	Temperature (-40°C~85°C)	Voltage (2.2V~5.5V)	Process	Total
1 MHz	\pm 3%	\pm 4%	\pm 2.5%	\pm 9.5%
4 MHz	\pm 3%	\pm 4%	\pm 2.5%	\pm 9.5%
8 MHz	\pm 3%	\pm 5%	\pm 2.5%	\pm 10.5%
16 MHz	\pm 3%	\pm 5%	\pm 2.5%	\pm 10.5%

3 Pin Assignment

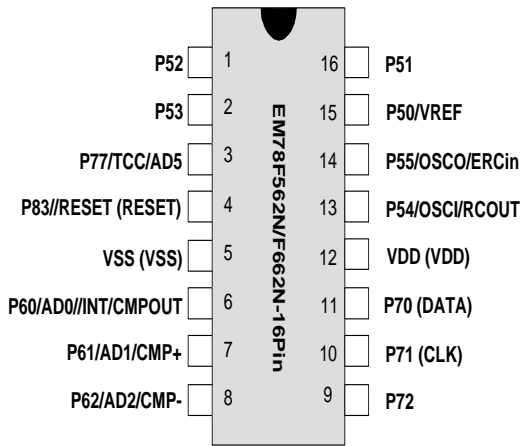

Figure 3-1 EM78F562N/F662ND16/SO16

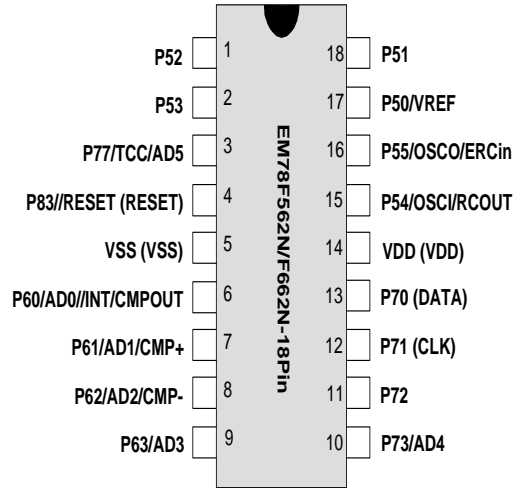

Figure 3-2 EM78F562N/F662ND18/SO18

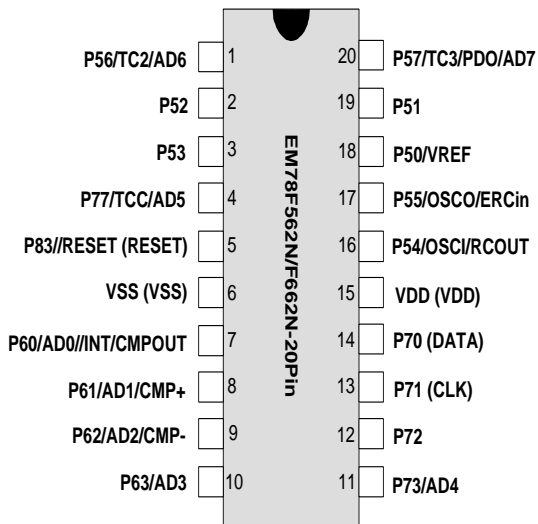

Figure 3-3 EM78F562N/F662ND20/SO20

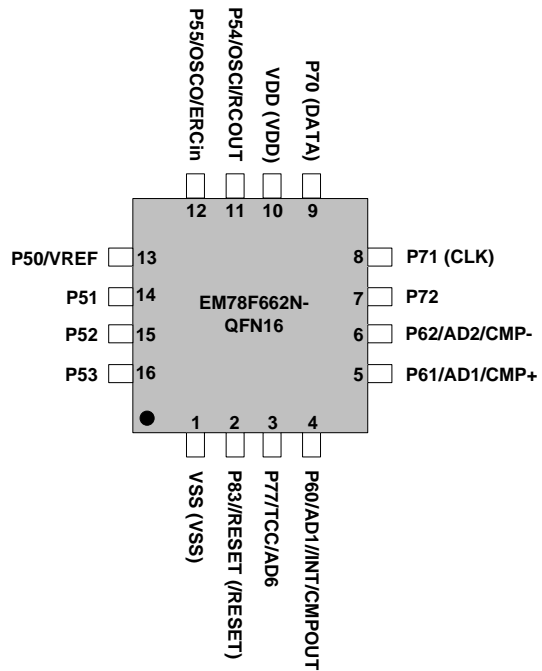

Figure 3-4 EM78F662NQFN16A

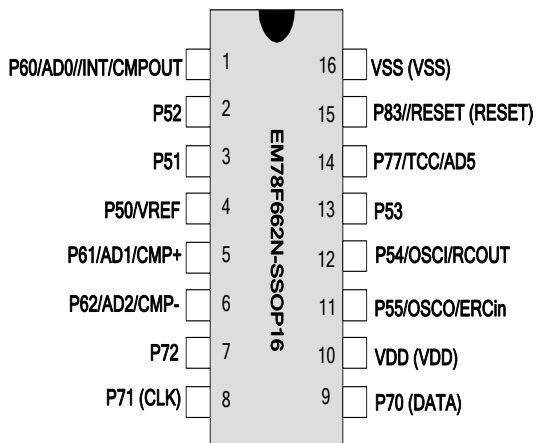

Figure 3-5 EM78F662NSS16

4 Pin Description

4.1 EM78F562N/F662N

Legend: **ST:** Schmitt Trigger input **AN:** analog pin
 CMOS: CMOS output **XTAL:** Oscillation pin for crystal / resonator

Name	Function	Input Type	Output Type	Description
P50/VREF	P50	ST	CMOS	Bidirectional I/O pin with programmable pull-down
	VREF	AN	–	ADC external voltage reference
P51	P51	ST	CMOS	Bidirectional I/O pin with programmable pull-down
P52	P52	ST	CMOS	Bidirectional I/O pin with programmable pull-down
P53	P53	ST	CMOS	Bidirectional I/O pin with programmable pull-down
P54/OSCI/RCOUT	P54	ST	CMOS	Bidirectional I/O pin
	OSCI	XTAL	–	Clock input of crystal/resonator oscillator
	RCOUT	–	CMOS	Clock output of internal RC oscillator Clock output of external RC oscillator (open-drain)
P55/OSCO/ERCin	P55	ST	CMOS	Bidirectional I/O pin
	OSCO	–	XTAL	Clock output of crystal/resonator oscillator
	ERCin	AN	–	External RC input pin
P56/TC2/AD6	P56	ST	CMOS	Bidirectional I/O pin
	TC2	ST	–	Timer 2 clock input
	AD6	AN	–	ADC Input 6
P57/TC3/PDO/AD7	P57	ST	CMOS	Bidirectional I/O pin
	TC3	ST	–	Timer 3 clock input
	PDO	–	CMOS	Programmable divider output
	AD7	AN	–	ADC Input 7
P60/AD0//INT/CMPOUT	P60	ST	CMOS	Bidirectional I/O pin with programmable pull-down, pull-high, open-drain, and pin change wake-up
	AD0	AN	–	ADC Input 0
	/INT	ST	–	External interrupt pin
	CMPOUT	–	CMOS	Comparator output
P61/AD1/CMP+	P61	ST	CMOS	Bidirectional I/O pin with programmable pull-down, pull-high, open-drain, and pin change wake-up
	AD1	AN	–	ADC Input 1
	CMP+	AN	–	Non-inverting end of comparator



(Continuation)

Name	Function	Input Type	Output Type	Description
P62/AD2/CMP-	P62	ST	CMOS	Bidirectional I/O pin with programmable pull-down, pull-high, open-drain, and pin change wake-up
	AD2	AN	–	ADC Input 2
	CMP-	AN	–	Inverting end of comparator
P63/AD3	P63	ST	CMOS	Bidirectional I/O pin with programmable pull-down, pull-high, open-drain, and pin change wake-up
	AD3	AN	–	ADC Input 3
P70 (DATA)	P70	ST	CMOS	Bidirectional I/O pin
	(DATA)	ST	CMOS	DATA pin for Writer programming
P71 (CLK)	P71	ST	CMOS	Bidirectional I/O pin
	(CLK)	ST	–	CLOCK pin for Writer programming
P72	P72	ST	CMOS	Bidirectional I/O pin
P73/AD4	P73	ST	CMOS	Bidirectional I/O pin
	AD4	AN	–	ADC Input 4
P77/TCC/AD5	P77	ST	CMOS	Bidirectional I/O pin
	TCC	ST	–	Real Time Clock/Counter clock input
	AD5	AN	–	ADC Input 5
P83//RESET (/RESET)	P83	ST	CMOS	Bidirectional I/O pin
	/RESET	ST	–	Internal pull-high reset pin
	(/RESET)	(/RESET)	ST	/RESET pin for Writer programming
VDD (VDD)	VDD	Power	–	Power
	VDD	Power	–	VDD for Writer programming
VSS (VSS)	VSS	Power	–	Ground
	VSS	Power	–	VSS for Writer programming

5 Block Diagram

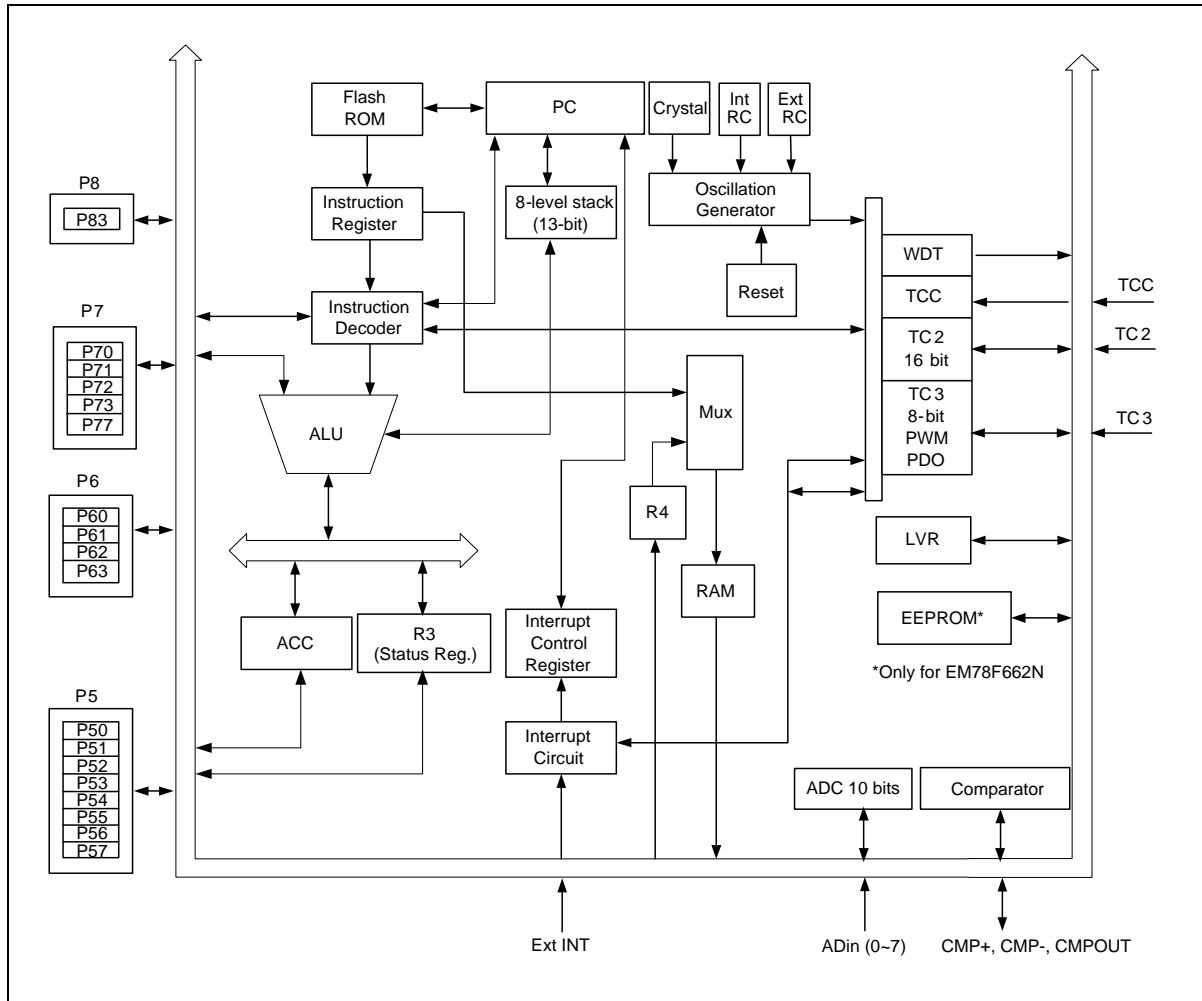

Figure 5-1 Functional Block Diagram

6 Functional Description

6.1 Operational Registers

6.1.1 R0 (Indirect Addressing Register)

R0 is not a physically implemented register. It is used as an indirect addressing pointer. Any instruction using R0 as a pointer actually accesses data pointed by the RAM Select Register (R4).

6.1.2 R1 (Timer Clock/Counter)

R1 is incremented by an external signal edge, which is defined by TE bit (CONT-4) through the TCC pin, or by the instruction cycle clock. It is writable and readable as any other registers. It is defined by resetting PSTE (CONT-3).

The prescaler is assigned to TCC, if the PSTE bit (CONT-3) is reset. The contents of the prescaler counter are cleared only when the TCC register is written with a value.

6.1.3 R2 (Program Counter) and Stack

Depending on the device type, R2 and hardware stack are **10**-bit wide. The structure is depicted in Figure 6-1.

The configuration structure generates **2K×13** bits on-chip Flash ROM addresses to the relative programming instruction codes. One program page is **1024** words long.

R2 is set as all “0”s when under a reset condition.

“JMP” instruction allows direct loading of the lower **10** program counter bits. Thus, “JMP” allows the PC to go to any location within a page (1K).

“CALL” instruction loads the lower 10 bits of the PC and PC+1 is pushed onto the stack. Thus, the subroutine entry address can be located anywhere within a page.

“LJMP” instruction allows direct loading of the lower 11 program counter bits. Thus, “LJMP” allows the PC to go to any location within 2K.

“LCALL” instruction loads the lower 11 bits of the PC and PC+1 is pushed onto the stack. Thus, the subroutine entry address can be located anywhere within 2K.

“RET” (“RETL k”, “RETI”) instruction loads the program counter with the contents of the top-level stack.

“ADD R2, A” allows a relative address to be added to the current PC, and the ninth and above bits of the PC will be incremented progressively.

“MOV R2, A” allows to load an address from the “A” register to the lower 8 bits of the PC, and the ninth and tenth bits of the PC remain unchanged.

Any instruction except “ADD R2,A” that is written to R2 (e.g. “MOV R2, A”, “BC R2, 6”) will cause the ninth bit and the tenth bits (A8~A9) of the PC to remain unchanged.

All instructions are single instruction cycle (fclk/2, fclk/4, fclk/8 or fclk/16) except for instructions that would change the contents of R2. Such instructions will need one more instruction cycle.

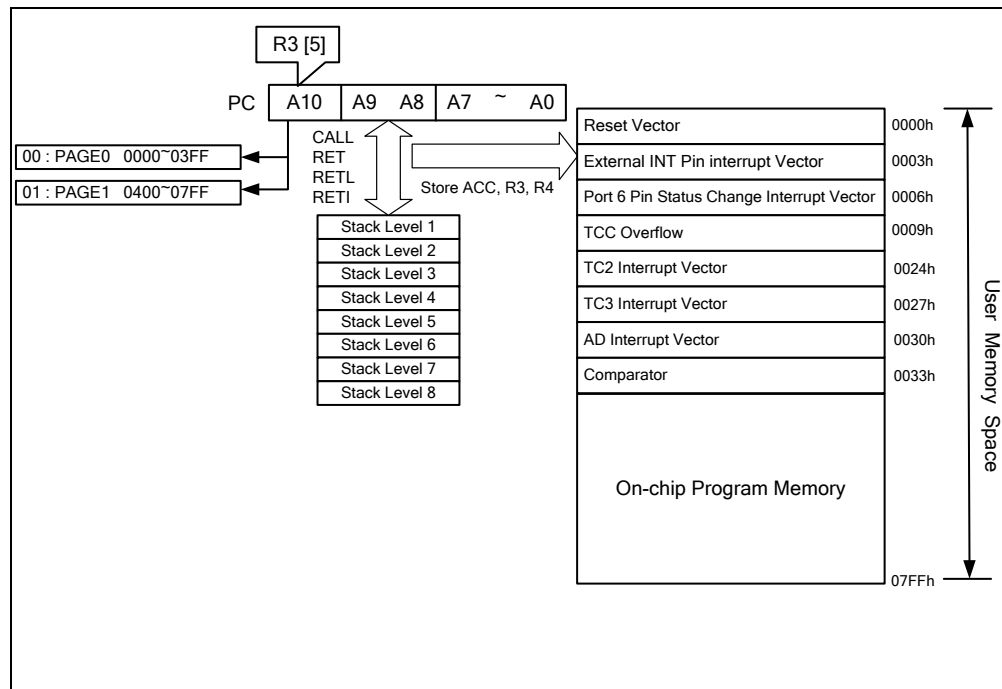

Figure 6-1 Program Counter Organization



	Register Bank 0	Register Bank 1	Register Bank 2	Register Bank 3	Control Register
Address					
01	R1 (TCC Buffer)				
02	R2 (PC)				
03	R3 (STATUS)				
04	R4 (RSR, Bank Select)	R4(7,6) (0,1)	(1,0)	(1,1)	
05	R5 (Port 5 I/O data)	R5 (Reserved)	R5 (ADC Input Select Register)	R5 (Reserved)	IOC5 (Port 5 I/O Control)
06	R6 (Port 6 I/O data)	R6 (Reserved)	R6 (ADC Control Register)	R6 (TBPTH)	IOC6 (Port 6 I/O Control)
07	R7 (Port 7 I/O data)	R7 (Reserved)	R7 (Reserved)	R7 (Reserved)	IOC7 (Port 7 I/O Control)
08	R8 (Port 8 I/O data)	R8 (Timer 2 Control)	R8 (AD high 8-bit Data Buffer)	R8 (Reserved)	IOC8 (Port 8 I/O Control)
09	R9 (TBPTL)	R9 (Timer 2 High Byte Data Buffer)	R9 (AD low 2-bit Data Buffer)	R9 (Reserved)	IOC9 (Reserved)
0A	RA (Wake-up Control Register)	RA (Timer 2 Low Byte Data Buffer)	RA (Reserved)	RA (Reserved)	IOCA (WDT Control)
0B	RB (EEPROM Control Register)	RB (Reserved)	RB (Comparator Control Register)	RB (Reserved)	IOCB (Pull-down Control Register 2)
0C	RC (EEPROM Address Register)	RC (Reserved)	RC (Reserved)	RC (Reserved)	IOCC (Open Drain Control Register)
0D	RD (EEPROM Data Register)	RD (Reserved)	RD (Reserved)	RD (Timer 3 Control)	IOCD (Pull-high Control Register 2)
0E	RE (CPU Operating Control Register)	RE (Reserved)	RE (Reserved)	RE (Timer 3 Data Buffer)	IOCE (Interrupt Mask Register 2)
0F	RF (Interrupt Flag 1)	RF (Interrupt Flag 2)	RF (Pull-high Control Register 1)	RF (Pull-down Control Register 1)	IOCF (Interrupt Mask Register 1)
10 : 1F	16-Byte Common Register				
20 : 3F	Bank 0 32x8	Bank 0 32x8	Bank 0 32x8	Bank 0 32x8	

Figure 6-2 Data Memory Configuration

6.1.4 R3 (Status Register)

Bit 7	Bit 6	Bit 5	Bit 4	Bit 3	Bit 2	Bit 1	Bit 0
-	-	-	T	P	Z	DC	C

Bit 7 ~ Bit 5: Not used, set to “0” at all time.

Bit 4 (T): Time-out bit

Set to “1” with the “SLEP” and “WDTC” commands, or during power up and reset to “0” by WDT time-out.

Bit 3 (P): Power down bit

Set to “1” during power on or by a “WDTC” command and reset to “0” by a “SLEP” command.

Bit 2 (Z): Zero flag

Set to “1” if the result of an arithmetic or logic operation is zero.

Bit 1 (DC): Auxiliary carry flag

Bit 0 (C): Carry flag

6.1.5 R4 (RAM Select Register)

Bits 7 ~ 6: Used to select Bank 0 ~ Bank 3

Bits 5 ~ 0: Used to select registers (Address: 00~3F) in indirect addressing mode.

See the *Data Memory Configuration* in Figure 6-2.

6.1.6 Bank 0 R5 ~ R8 (Port 5 ~ Port 8)

R5 ~ R7 are I/O registers.

6.1.7 Bank 0 R9 TBPTL (Low Byte of Table Pointer Register)

Bit 7	Bit 6	Bit 5	Bit 4	Bit 3	Bit 2	Bit 1	Bit 0
RBit7	RBit6	RBit5	RBit4	RBit3	RBit2	RBit1	RBit0

6.1.8 Bank 0 RA (Wake-up Control Register)

Bit 7	Bit 6	Bit 5	Bit 4	Bit 3	Bit 2	Bit 1	Bit 0
-	ICWE	ADWE	EXWE	-	-	CMPWE	-

Bit 7: Not used, set to “0” at all time.

Bit 6 (ICWE): Port 6 input status change wake-up enable bit

0 : Disable Port 6 input status change wake-up

1 : Enable Port 6 input status change wake-up

Bit 5 (ADWE): ADC wake-up enable bit

0 : Disable ADC wake-up

1 : Enable ADC wake-up

When ADC completed status is used to enter an interrupt vector or to wake-up the EM78F562N/F662N from sleep, with A/D conversion running, the ADWE bit must be set to “Enable”.

Bit 4 (EXWE): External wake-up enable bit

0 : Disable External /INT pin wake-up

1 : Enable External /INT pin wake-up

Bit 2: Not used, set to “0” at all time

Bit 1 (CMPWE): Comparator wake-up enable bit

0 : Disable Comparator wake-up

1 : Enable Comparator wake-up

Bits 3, 0: Not used, set to “0” at all time

6.1.9 Bank 0 RB (EEPROM Control Register)

Bit 7	Bit 6	Bit 5	Bit 4	Bit 3	Bit 2	Bit 1	Bit 0
RD	WR	EEWE	EEDF	EEPC	-	-	-

Bit 7 (RD): Read control register

0 : Does not execute EEPROM read

1 : Read EEPROM content, (RD can be set by software, and cleared by hardware after Read instruction is completed)

Bit 6 (WR): Write control register

0 : Write cycle to the EEPROM is complete.

1 : Initiate a write cycle, (WR can be set by software, WR is cleared by hardware after Write cycle is completed)

Bit 5 (EEWE): EEPROM Write Enable bit.

0 : Prohibit write to the EEPROM

1 : Allows EEPROM write cycles

Bit 4 (EEDF): EEPROM Detective Flag

0 : Write cycle is completed

1 : Write cycle is unfinished

Bit 3 (EEPC): EEPROM power-down control bit

0 : Switch off the EEPROM

1 : EEPROM is operating

Bits 2 ~ 0: Not used, set to “0” at all time

**This register is only for EM78F662N.*

6.1.10 Bank 0 RC (128 Bytes EEPROM Address)

Bit 7	Bit 6	Bit 5	Bit 4	Bit 3	Bit 2	Bit 1	Bit 0
-	EE_A6	EE_A5	EE_A4	EE_A3	EE_A2	EE_A1	EE_A0

Bits 6 ~ 0: 128 bytes EEPROM address

**This register is only for EM78F662N.*

6.1.11 Bank 0 RD (128 Bytes EEPROM Data)

Bit 7	Bit 6	Bit 5	Bit 4	Bit 3	Bit 2	Bit 1	Bit 0
EE_D7	EE_D6	EE_D5	EE_D4	EE_D3	EE_D2	EE_D1	EE_D0

Bits 7 ~ 0: 128 bytes EEPROM data

**This register is only for EM78F662N.*

6.1.12 Bank 0 RE (CPU Operating Control Register)

Bit 7	Bit 6	Bit 5	Bit 4	Bit 3	Bit 2	Bit 1	Bit 0
-	TIMERSC	CPUS	IDLE-	-	-	-	-

Bit 7: Not used, set to “0” at all time

Bit 6 (TIMERSC): TCC, TC2, TC3 clock source select

0 : Fs. Fs stands for the sub frequency for WDT internal RC time base.

1 : Fm. Fm stands for the main-oscillator clock

Bit 5 (CPUS): CPU Oscillator Source Select

0 : sub-oscillator (fs)

1 : main oscillator (fosc)

When CPUS=0, the CPU oscillator selects the sub-oscillator and the main oscillator is stopped.

Bit 4 (IDLE): Idle Mode Enable Bit. This bit will determine which mode to enter after SLEP instruction is executed.

0 : IDLE=“0”+SLEP instruction → sleep mode

1 : IDLE=“1”+SLEP instruction → idle mode

CPU Operation Mode

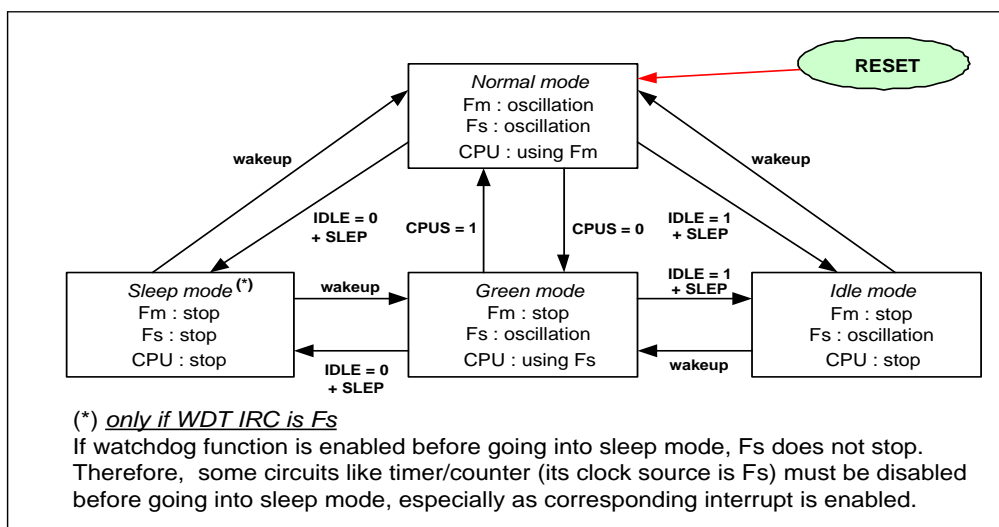

Figure 6-3 CPU Operation Mode

Bits 3 ~ 0: Not used, set to "0" at all time

6.1.13 Bank 0 RF (Interrupt Status Register)

Bit 7	Bit 6	Bit 5	Bit 4	Bit 3	Bit 2	Bit 1	Bit 0
CMPIF	ADIF	-	-	-	EXIF	ICIF	TCIF

Note: "1" means with interrupt request "0" means no interrupt occurs

Bit 7 (CMPIF): Comparator Interrupt flag. Set when a change occurs in the Comparator output. Reset by software.

Bit 6 (ADIF): Interrupt flag for analog to digital conversion. Set when AD conversion is completed, reset by software.

Bits 5 ~ 3: Not used, set to "0" at all time.

Bit 2 (EXIF): External interrupt flag. Set by a falling edge on the /INT pin, reset by software.

Bit 1 (ICIF): Port 6 Input Status Change Interrupt flag. Set when Port 6 input changes, reset by software.

Bit 0 (TCIF): TCC overflow interrupt flag. Set when TCC overflows, reset by software.

Bank 0 RF can be cleared by instruction but cannot be set.

IOCF is the interrupt mask register.

Note that the result of reading Bank 0 RF is the "Logic AND" of Bank 0 RF and IOCF.

6.1.14 R10 ~ R3F

All of these are 8-bit general-purpose registers.

6.1.15 Bank 1 R5 ~R7

These are reserved registers.

6.1.16 Bank 1 R8 TC2CR (Timer 2 Control)

Bit 7	Bit 6	Bit 5	Bit 4	Bit 3	Bit 2	Bit 1	Bit 0
RCM1	RCM0	TC2ES	TC2M	TC2S	TC2CK2	TC2CK1	TC2CK0

Bit 7 and Bit 6 (RCM1, RCM0): IRC mode select bits

Writer Trim IRC	Bank 1 R8<7,6>		Frequency	Operating Voltage Range	Stable Time
	RCM1	RCM0			
4 MHz	0	0	4 MHz \pm 2.5%	2.2V~5.5V	<5 μ s
	0	1	16 MHz \pm 10%	4.5V~5.5V	<1.5 μ s
	1	0	8 MHz \pm 10%	3.0V~5.5V	<3 μ s
	1	1	1 MHz \pm 10%	2.2V~5.5V	<22 μ s
16 MHz	0	0	4 MHz \pm 10%	2.2V~5.5V	<6 μ s
	0	1	16 MHz \pm 2.5%	4.5V~5.5V	<1.25 μ s
	1	0	8 MHz \pm 10%	3.0V~5.5V	<3 μ s
	1	1	1 MHz \pm 10%	2.2V~5.5V	<22 μ s
8 MHz	0	0	4 MHz \pm 10%	2.2V~5.5V	<6 μ s
	0	1	16 MHz \pm 10%	4.5V~5.5V	<1.5 μ s
	1	0	8 MHz \pm 2.5%	3.0V~5.5V	<2.5 μ s
	1	1	1 MHz \pm 10%	2.2V~5.5V	<22 μ s
1 MHz	0	0	4 MHz \pm 10%	2.2V~5.5V	<6 μ s
	0	1	16 MHz \pm 10%	4.5V~5.5V	<1.5 μ s
	1	0	8 MHz \pm 10%	3.0V~5.5V	<3 μ s
	1	1	1 MHz \pm 2.5%	2.2V~5.5V	<20 μ s

For Example:

NOTE
<ul style="list-style-type: none"> ■ The initial values of Bank 1 R8<7, 6> will be kept the same as Word 1<3, 2>. ■ If user changes the IRC frequency from A-frequency to B-frequency, the F902N needs to wait for some time for it to work. The waiting time corresponds to the B-frequency. <p>ex : Writer trim IRC 4 MHz \rightarrow Bank 1 R8<7, 6> set to "10" \rightarrow holds 3 μs \rightarrow F902N works on 8 MHz \pm 10%</p>

Code Option Word 1 COBS = 0:

The initialized values of R8<7, 6> will be kept the same as Word 1<3, 2>.

The R8<7, 6> cannot change the frequency.

Code Option Word 1 COBS = 1:

The initialized values of R8<7, 6> will be kept the same as Word 1<3, 2>.

The R8<7, 6> can change, when user wants to work on other IRC frequency.

Bit 5 (TC2ES): TC2 signal edge

0 : incremented if a transition from low to high (rising edge) takes place on the TC2 pin

1 : incremented if a transition from high to low (falling edge) takes place on the TC2 pin

Bit 4 (TC2M): Timer/Counter 2 mode select

0 : Timer/counter mode

1 : Window mode

Bit 3 (TC2S): Timer/Counter 2 start control

0 : Stop and clear the counter

1 : Start

Bit 2 ~ Bit 0 (TC2CK2 ~ TC2CK0): Timer/Counter 2 clock source select

TC2CK2	TC2CK1	TC2CK0	Clock Source	Resolution	Max. Time
			Normal	Fc=8M	Fc=8M
0	0	0	$Fc/2^{23}$	1.05 sec	19.1 hr
0	0	1	$Fc/2^{13}$	1.02 ms	1.1 min
0	1	0	$Fc/2^8$	32 μ s	2.1 sec
0	1	1	$Fc/2^3$	1 μ s	65.5 ms
1	0	0	Fc	125 ns	7.9 ms
1	0	1	–	–	–
1	1	0	–	–	–
1	1	1	External clock (TC2 pin)	–	–

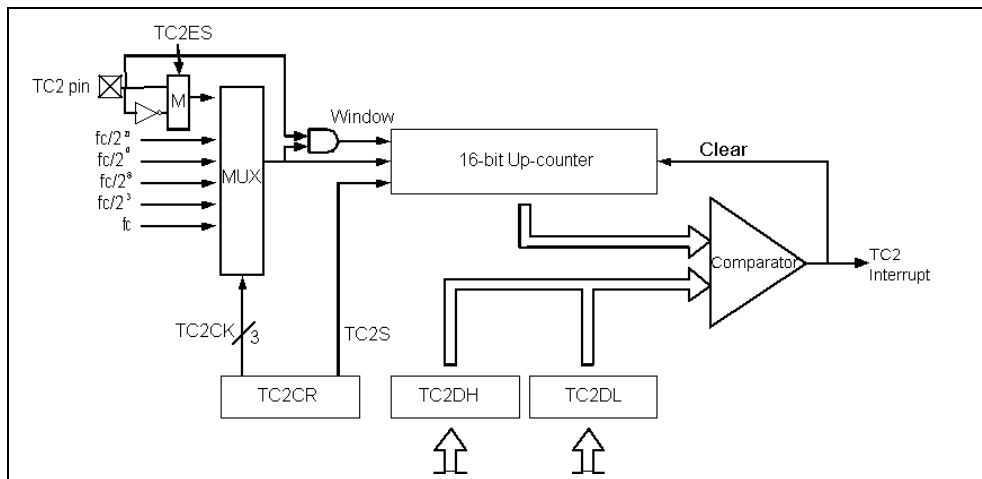

Figure 6-4 Configuration of Timer / Counter 2

In **Timer mode**, counting up is performed using the internal clock. When the contents of up-counter matched the TCR2 (TCR2H+TCR2L), then interrupt is generated and the counter is cleared. Counting up resumes after the counter is cleared.

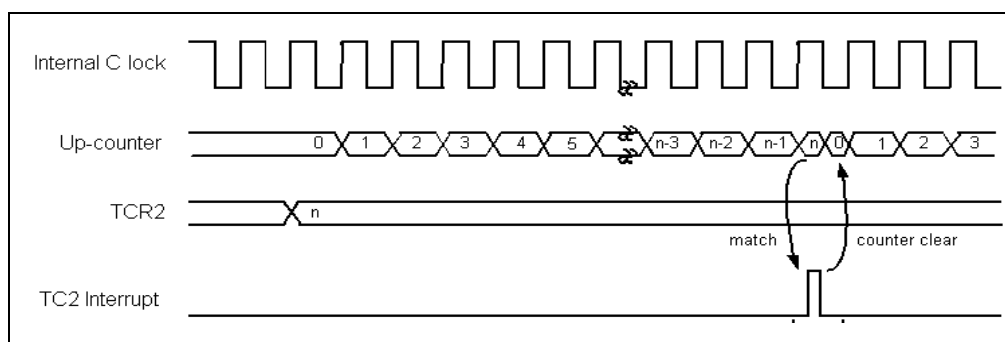

Figure 6-5 Timer Mode Timing Chart

In **Counter mode**, counting up is performed using the external clock input pin (TC2 pin) and either rising or falling can be selected by setting TC2ES. When the contents of up-counter matched the TCR2 (TCR2H+TCR2L), then interrupt is generated and the counter is cleared. Counting up resumes after the counter is cleared.

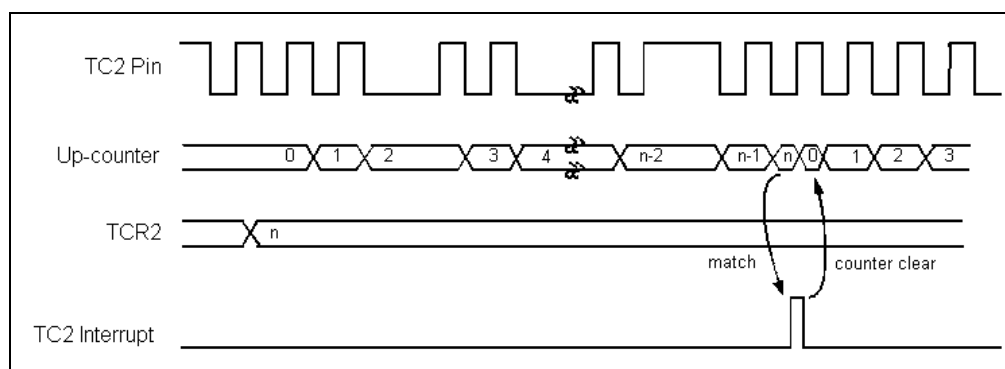

Figure 6-6 Counter Mode Timing Chart

In **Window mode**, counting up is performed on a rising edge of the pulse that is logical AND of an internal clock and the TC2 pin (window pulse). When the contents of the up-counter matched the TCR2 (TCR2H+TCR2L), interrupt is generated and the counter is cleared. The frequency (window pulse) must be slower than the selected internal clock.

In writing to the TCR2L, comparison is inhibited until TCR2H is written.

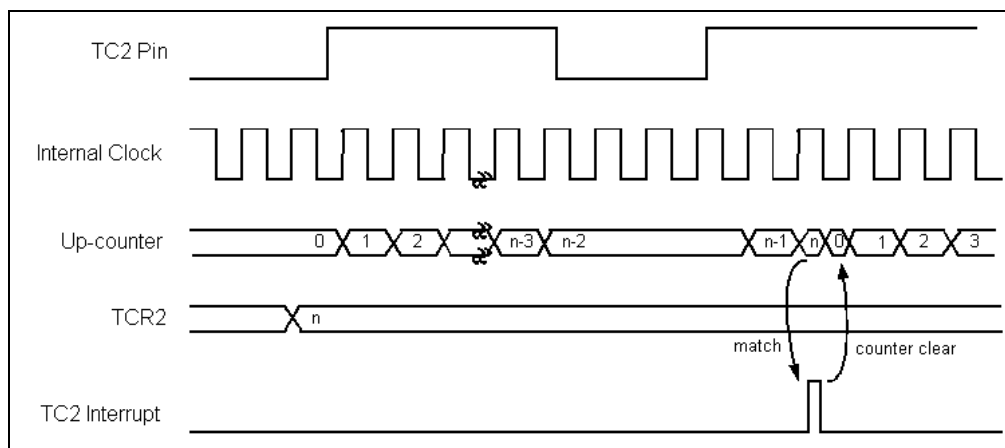

Figure 6-7 Window Mode Timing Chart

6.1.17 Bank 1 R9 TC2DH (Timer 2 High Byte Data Buffer)

Bit 7	Bit 6	Bit 5	Bit 4	Bit 3	Bit 2	Bit 1	Bit 0
TC2D15	TC2D14	TC2D13	TC2D12	TC2D11	TC2D10	TC2D9	TC2D8

Bit 7 ~ Bit 0 (TC2D8 ~ TC2D15): High byte data buffer of 16-bit Timer/Counter 2.

6.1.18 Bank 1 RA TC2DL (Timer 2 Low Byte Data Buffer)

Bit 7	Bit 6	Bit 5	Bit 4	Bit 3	Bit 2	Bit 1	Bit 0
TC2D7	TC2D6	TC2D5	TC2D4	TC2D3	TC2D2	TC2D1	TC2D0

Bit 7 ~ Bit 0 (TC2D7 ~ TC2D0): Low byte data buffer of 16-bit Timer/Counter 2.

6.1.19 Bank 1 RB ~RE

These are reserved registers.

6.1.20 Bank 1 RF (Interrupt Status Register)

Bit 7	Bit 6	Bit 5	Bit 4	Bit 3	Bit 2	Bit 1	Bit 0
-	-	TCIF3	TCIF2	-	-	-	-

Note: “1” means with interrupt request “0” means no interrupt occurs

Bits 7 ~ 6: Not used, set to “0” at all time

Bit 5 (TCIF3): 8-bit Timer/Counter 3 interrupt flag. Interrupt flag is cleared by software.

Bit 4 (TCIF2): 16-bit Timer/Counter 2 interrupt flag. Interrupt flag is cleared by software.

RF can be cleared by instruction but cannot be set.

IOCE is the interrupt mask register.

Note that the result of reading Bank 1 RF is the "logic AND" of Bank 1 RF and IOCE.

Bits 3 ~ 0: Not used, set to "0" at all time.

6.1.21 Bank 2 R5 AISR (ADC Input Select Register)

The AISR register for ADC pins as analog input or as digital I/O.

Bit 7	Bit 6	Bit 5	Bit 4	Bit 3	Bit 2	Bit 1	Bit 0
ADE7	ADE6	ADE5	ADE4	ADE3	ADE2	ADE1	ADE0

Bit 7 (ADE7): AD converter enable bit of P57 pin.

0 : Disable ADC7, P57 act as I/O pin.

1 : Enable ADC7 to act as analog input pin.

Bit 6 (ADE6): AD converter enable bit of P56 pin.

0 : Disable ADC6, P56 act as I/O pin.

1 : Enable ADC6 to act as analog input pin.

Bit 5 (ADE5): AD converter enable bit of P77 pin

0 : Disable ADC5, P77 functions as I/O pin.

1 : Enable ADC5 to function as analog input pin.

Bit 4 (ADE4): AD converter enable bit of P73 pin

0 : Disable ADC4, P73 act as I/O pin.

1 : Enable ADC4 to act as analog input pin.

Bit 3 (ADE3): AD converter enable bit of P63 pin.

0 : Disable ADC3, P63 act as I/O pin.

1 : Enable ADC3 to act as analog input pin.

Bit 2 (ADE2): AD converter enable bit of P62 pin.

0 : Disable ADC2, P62 act as I/O pin.

1 : Enable ADC2 to act as analog input pin.

Bit 1 (ADE1): AD converter enable bit of P61 pin.

0 : Disable ADC1, P61 functions as I/O pin.

1 : Enable ADC1 to function as analog input pin.

Bit 0 (ADE0): AD converter enable bit of P60 pin.

0 : Disable ADC0, P60 act as I/O pin.

1 : Enable ADC0 to act as analog input pin.

The following table shows the priority of P60/AD1//INT/CMPOUT.

P60/AD1//INT/CMPOUT Pin Priority			
High	Medium	Medium	Low
/INT	CMPOUT	AD0	P60

6.1.22 Bank 2 R6 ADCON (A/D Control Register)

Bit 7	Bit 6	Bit 5	Bit 4	Bit 3	Bit 2	Bit 1	Bit 0
VREFS	CKR1	CKR0	ADRUN	ADPD	ADIS2	ADIS1	ADIS0

Bit 7 (VREFS): The input source of the Vref of the ADC.

0 : Vref of the ADC is connected to Vdd (default value), and the P50/VREF pin carries out the function of P50

1 : Vref of the ADC is connected to P50/VREF

Bit 6 ~ Bit 5 (CKR1 ~ CKR0): The prescaler of oscillator clock rate of ADC

CKR1/CKR0	Operation Mode	Max. Operation Frequency
00	$F_{osc}/4$	4 MHz
01	F_{osc}	1 MHz
10	$F_{osc}/16$	16 MHz
11	$F_{osc}/2$	2 MHz

Bit 4 (ADRUN): ADC starts to run

0 : reset upon completion of AD conversion. This bit cannot be reset by software.

1 : A/D conversion is started. This bit can be set by software.

Bit 3 (ADPD): ADC Power-down mode

0 : switch off the resistor reference to save power even while the CPU is operating

1 : ADC is operating

Bits 2 ~ 0 (ADIS2 ~ ADIS0): AD Input Select Bits

ADIS2	ADIS1	ADIS0	AD Input Pin
0	0	0	AD0
0	0	1	AD1
0	1	0	AD2
0	1	1	AD3
1	0	0	AD4
1	0	1	AD5
1	1	0	AD6
1	1	1	AD7

6.1.23 Bank 2 R7 ADOC (A/D Offset Calibration Register)

Bit 7	Bit 6	Bit 5	Bit 4	Bit 3	Bit 2	Bit 1	Bit 0
CALI	SIGN	VOF[2]	VOF[1]	VOF[0]	-	-	-

Bit 7 (CALI): Calibration enable bit for A/D offset

0 : Disable calibration

1 : Enable calibration

Bit 6 (SIGN): Polarity bit of offset voltage

0 : Negative voltage

1 : Positive voltage

Bits 5 ~ 3 (VOF[2] ~ VOF[0]): Offset voltage bits

VOF[2]	VOF[1]	VOF[0]	Offset
0	0	0	0LSB
0	0	1	1LSB
0	1	0	2LSB
0	1	1	3LSB
1	0	0	4LSB
1	0	1	5LSB
1	1	0	6LSB
1	1	1	7LSB

Bits 2 ~ 0: Not used, set to "0" at all time.

6.1.24 Bank 2 R8 ADDH (AD High 8-Bit Data Buffer)

Bit 7	Bit 6	Bit 5	Bit 4	Bit 3	Bit 2	Bit 1	Bit 0
ADD9	ADD8	ADD7	ADD6	ADD5	ADD4	ADD3	ADD2

When the A/D conversion is completed, the result of high 8-bit is loaded into the ADDH. The ADRUN bit is cleared, and the ADIF is set. R8 is read only.

6.1.25 Bank 2 R9 ADDL (AD Low 2-Bit Data Buffer)

Bit 7	Bit 6	Bit 5	Bit 4	Bit 3	Bit 2	Bit 1	Bit 0
-	-	-	-	-	-	ADD1	ADD0

Bits 7 ~ 2: Not used, set to "0" at all time.

6.1.26 Bank 2 RA, RC ~ RE

These are reserved registers.

6.1.27 Bank 2 RB CMPCON (Comparator Control Register)

Bit 7	Bit 6	Bit 5	Bit 4	Bit 3	Bit 2	Bit 1	Bit 0
-	-	-	-	-	CPOUT	CPS1	CPS0

Bits 7 ~ 3: Not used. Set to “0” at all time.

Bit 2 (CPOUT): Result of the Comparator output

NOTE			
<i>The P60/AD1/INT/CMPOUT pin priority is as follows:</i>			
Priority			
High	Medium	Medium	Low
INT	CMPOUT	AD0	P60

Bit 1 ~ Bit 0 (CPS1 ~ CPS0): Comparator Select bits

CO3S1	CO3S0	Function Description
0	0	Comparator is not used. P60 functions as normal I/O pin.
0	1	Used as Comparator and P60 functions as normal I/O pin.
1	0	Used as Comparator and P60 functions as Comparator output pin (CMPOUT)
1	1	Reserved

NOTE		
<i>The P61/AD1/CMP+ pin priority is as follows:</i>		
Priority		
High	Medium	Low
CMP+	AD1	P61

NOTE		
<i>The P62/AD2/CMP- pin priority is as follows:</i>		
Priority		
High	Medium	Low
CMP-	AD2	P62

6.1.28 Bank 2 RF (Pull-high Control Register 1)

Bit 7	Bit 6	Bit 5	Bit 4	Bit 3	Bit 2	Bit 1	Bit 0
-	-	-	-	/PH73	/PH72	/PH71	/PH70

Bits 7 ~ 4: Not used, set to “0” at all time.

Bit 3 (/PH73): Control bit used to enable pull-high of the P73 pin.

0 : Enable internal pull-high

1 : Disable internal pull-high

Bit 2 (/PH72): Control bit used to enable pull-high of the P72 pin.

Bit 1 (/PH71): Control bit used to enable pull-high of the P71 pin.

Bit 0 (/PH70): Control bit used to enable pull-high of the P70 pin.

The RF Register is both readable and writable.

6.1.29 Bank 3 R5

Reserved Register

6.1.30 Bank 3 R6 TBPTH (High Byte of Table Pointer Register)

Bit 7	Bit 6	Bit 5	Bit 4	Bit 3	Bit 2	Bit 1	Bit 0
MLB	-	-	-	-	RBit10	RBit9	RBit8

Bit 7 (MLB): Take MSB or LSB at machine code.

Bits 6 ~ 3: No used. Set to “0” at all time.

Bits 2 ~ 0: Table point Address Bits 10 ~ 8.

6.1.31 Bank 3 R7~RC

Reserved Registers

6.1.32 Bank 3 RD TC3CR (Timer 3 Control)

Bit 7	Bit 6	Bit 5	Bit 4	Bit 3	Bit 2	Bit 1	Bit 0
TC3FF1	TC3FF0	TC3S	TC3CK2	TC3CK1	TC3CK0	TC3M1	TC3M0

Bit 7 ~ Bit 6 (TC3FF1 ~ TC3FF0): Timer/Counter 3 flip-flop control

TC3FF1	TC3FF0	Operating Mode
0	0	Clear
0	1	Toggle
1	0	Set
1	1	Reserved

Bit 5 (TC3S): Timer/Counter 3 start control

0 : Stop and clear the counter

1 : Start

Bit 4 ~ Bit 2 (TC3CK2 ~ TC3CK0): Timer/Counter 3 clock source select

TC3CK2	TC3CK1	TC3CK0	Clock Source	Resolution	Max. Time
			Normal	Fc=8M	Fc=8M
0	0	0	$Fc/2^{11}$	250 μ s	64 ms
0	0	1	$Fc/2^7$	16 μ s	4 ms
0	1	0	$Fc/2^5$	4 μ s	1 ms
0	1	1	$Fc/2^3$	1 μ s	255 μ s
1	0	0	$Fc/2^2$	500 ns	127.5 μ s
1	0	1	$Fc/2^1$	250 ns	63.8 μ s
1	1	0	Fc	125 ns	31.9 μ s
1	1	1	External clock (TC3 pin)	-	-

Bit 1 ~ Bit 0 (TC3M1 ~ TC3M0): Timer/Counter 3 operating mode select

TC3M1	TC3M0	Operating Mode
0	0	Timer/Counter
0	1	Reserved
1	0	Programmable Divider output
1	1	Pulse Width Modulation output

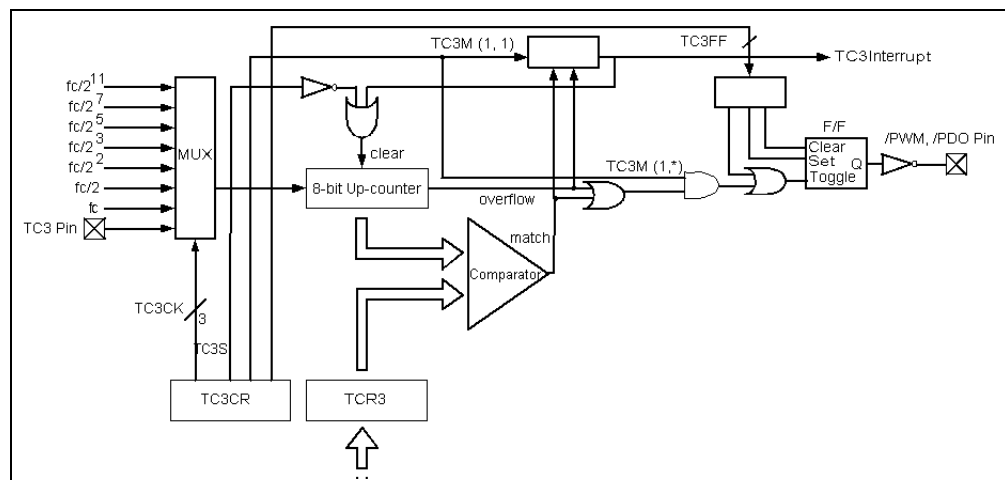

Figure 6-8 Timer / Counter 3 Configuration

In Timer Mode, counting up is performed using internal clock (rising edge trigger). When the contents of the up-counter match the TCR3, interrupt is generated and the counter is cleared. Counting up resumes after the counter is cleared.

In Counter Mode, counting up is performed using external clock input pin (TC3 pin). When the contents of the up-counter match the TCR3, then interrupt is generated and the counter is cleared. Counting up resumes after the counter is cleared.

In Programmable Divider Output (PDO) Mode, counting up is performed using the internal clock. The contents of TCR3 are compared with the contents of the up-counter. The F/F output is toggled and the counter is cleared each time a match is found. The F/F output is inverted and output to /PDO pin. This mode can generate 50% duty pulse output. The F/F can be initialized by the program and it is initialized to “0” during reset. A TC3 interrupt is generated each time the /PDO output is toggled.

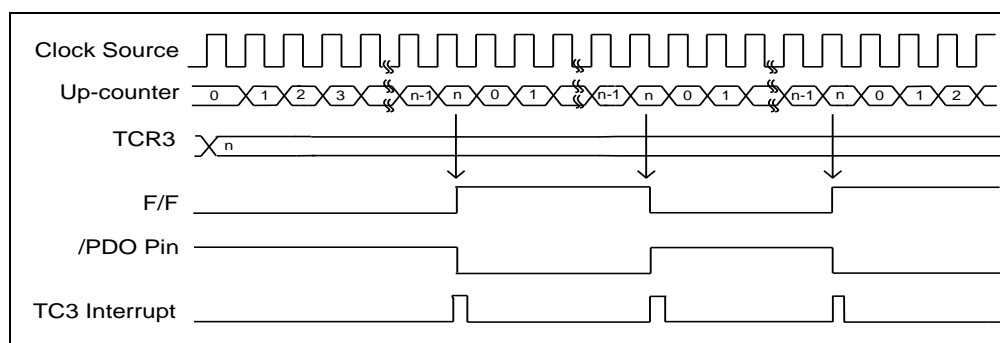

Figure 6-9 PDO Mode Timing Chart

In Pulse Width Modulation (PWM) Output mode, counting up is performed using internal clock. The contents of TCR3 are compared with the contents of the up-counter. The F/F is toggled when a match is found. The counter continues counting, the F/F is toggled again when the counter overflows, after which the counter is cleared. The F/F output is inverted and output to /PWM pin. A TC3 interrupt is generated each time an overflow occurs. TCR3 is configured as a 2-stage shift register and, during output, will not switch until one output cycle is completed even if TCR3 is overwritten. Therefore, the output can be changed continuously. Also, the first time, TRC3 is shifted by setting TC3S to “1” after data is loaded to TCR3.

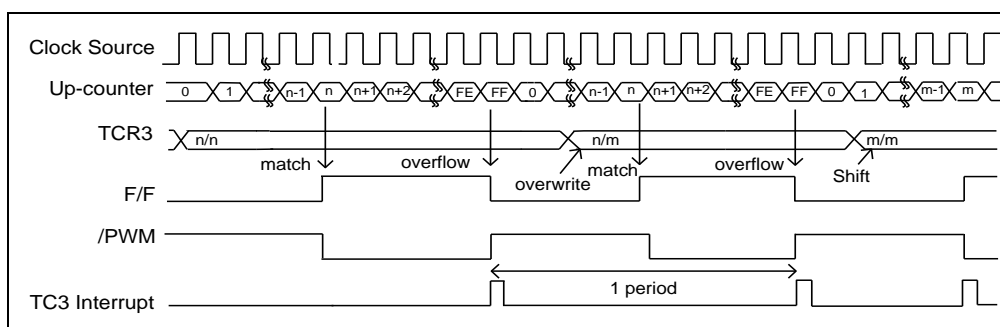

Figure 6-10 PWM Mode Timing Chart

6.1.33 Bank 3 RE TC3D (Timer 3 Data Buffer)

Bit 7	Bit 6	Bit 5	Bit 4	Bit 3	Bit 2	Bit 1	Bit 0
TC3D7	TC3D6	TC3D5	TC3D4	TC3D3	TC3D2	TC3D1	TC3D0

Bit 7 ~ Bit 0 (TC3D7 ~ TC3D0): Data Buffer of 8-bit Timer/Counter 3

6.1.34 Bank 3 RF (Pull-down Control Register 1)

Bit 7	Bit 6	Bit 5	Bit 4	Bit 3	Bit 2	Bit 1	Bit 0
-	-	-	-	/PD73	/PD72	/PD71	/PD70

Bit 7~ Bit 4: Not used, set to "0" at all time

Bit 3 (/PD73): Control bit used to enable pull-down of the P73 pin

0 : Enable internal pull-down

1 : Disable internal pull-down

Bit 2 (/PD72): Control bit used to enable pull-down of the P72 pin.

Bit 1 (/PD71): Control bit used to enable pull-down of the P71 pin.

Bit 0 (/PD70): Control bit used to enable pull-down of the P70 pin.

The RF Register is both readable and writable.

6.2 Special Function Registers

6.2.1 A (Accumulator)

Internal data transfer operation, or instruction operand holding usually involves the temporary storage function of the Accumulator, which is not an addressable register.

6.2.2 CONT (Control Register)

Bit 7	Bit 6	Bit 5	Bit 4	Bit 3	Bit 2	Bit 1	Bit 0
INTE	/INT	TS	TE	PSTE	PST2	PST1	PST0

Bit 7 (INTE): INT Signal Edge

0 : interrupt occurs at a rising edge of the INT pin

1 : interrupt occurs at a falling edge of the INT pin

Bit 6 (/INT): Interrupt Enable Flag

0 : masked by DISI or hardware interrupt

1 : enabled by ENI/RETI instructions

Bit 5 (TS): TCC Signal Source

0 : internal instruction cycle clock

1 : transition on the TCC pin

Bit 4 (TE): TCC Signal Edge

0 : increment if a transition from low to high takes place on TCC pin

1 : increment if a transition from high to low takes place on TCC pin

Bit 3 (PSTE): Prescaler Enable bit for TCC

0 : prescaler disable bit, TCC rate is 1:1

1 : prescaler enable bit, TCC rate is set at Bit 2 ~ Bit 0

Bit 2 ~ Bit 0 (PST 2 ~ PST0): TCC prescaler bits

PST2	PST1	PST0	TCC Rate
0	0	0	1:2
0	0	1	1:4
0	1	0	1:8
0	1	1	1:16
1	0	0	1:32
1	0	1	1:64
1	1	0	1:128
1	1	1	1:256

CONT register is both readable and writable.

6.2.3 IOC5 ~ IOC8 (I/O Port Control Register)

A value of "1" sets the relative I/O pin into high impedance, while "0" defines the relative I/O pin as output.

IOC5, IOC6 IOC7 and IOC8 registers are both readable and writable.

6.2.4 IOC9

Reserved registers

6.2.5 IOCA (WDT Control Register)

Bit 7	Bit 6	Bit 5	Bit 4	Bit 3	Bit 2	Bit 1	Bit 0
WDTE	EIS	-	-	PSWE	PSW2	PSW1	PSW0

Bit 7 (WDTE): Control bit used to enable the Watchdog timer

0 : Disable WDT

1 : Enable WDT

WDTE is both readable and writable.

Bit 6 (EIS): Control bit used to define the function of P60 (/INT) pin

0 : P60, bidirectional I/O pin

1 : /INT, external interrupt pin. In this case, the I/O control bit of P60 (Bit 0 of IOC6) must be set to "1".

When EIS is "0", the path of /INT is masked. When EIS is "1", the status of /INT pin can also be read by way of reading Port 6 (R6).

EIS is both readable and writable.

Bits 5 ~ 4: Not used, set to "0" at all time

Bit 3 (PSWE): Prescaler Enable bit for WDT

0 : prescaler disable bit, WDT rate is 1:1

1 : prescaler enable bit, WDT rate is set as Bit 0~Bit 2

Bit 2 ~ Bit 0 (PSW2 ~ PSW0): WDT prescaler bits

PSW2	PSW1	PSW0	WDT Rate
0	0	0	1:2
0	0	1	1:4
0	1	0	1:8
0	1	1	1:16
1	0	0	1:32
1	0	1	1:64
1	1	0	1:128
1	1	1	1:256

6.2.6 IOCB (Pull-down Control Register 2)

Bit 7	Bit 6	Bit 5	Bit 4	Bit 3	Bit 2	Bit 1	Bit 0
/PD7	/PD6	/PD5	/PD4	/PD3	/PD2	/PD1	/PD0

Bit 7 (/PD7): Control bit used to enable pull-down of the P63 pin.

0 : Enable internal pull-down

1 : Disable internal pull-down

Bit 6 (/PD6): Control bit used to enable pull-down of the P62 pin.

Bit 5 (/PD5): Control bit used to enable pull-down of the P61 pin.

Bit 4 (/PD4): Control bit used to enable pull-down of the P60 pin.

Bit 3 (/PD3): Control bit used to enable pull-down of the P53 pin.

Bit 2 (/PD2): Control bit used to enable pull-down of the P52 pin.

Bit 1 (/PD1): Control bit used to enable pull-down of the P51 pin.

Bit 0 (/PD0): Control bit used to enable pull-down of the P50 pin.

The IOCB Register is both readable and writable.

6.2.7 IOCC (Open-drain Control Register)

Bit 7	Bit 6	Bit 5	Bit 4	Bit 3	Bit 2	Bit 1	Bit 0
-	-	-	-	OD3	OD2	OD1	OD0

Bits 7 ~ 4: Not used, set to "0" at all time.

Bit 3 (OD3): Control bit used to enable open-drain output of the P63 pin.

0 : Disable open-drain output

1 : Enable open-drain output

Bit 2 (OD2): Control bit used to enable open-drain output of the P62 pin.

Bit 1 (OD1): Control bit used to enable open-drain output of the P61 pin.

Bit 0 (OD0): Control bit used to enable open-drain output of the P60 pin.

The IOCC Register is both readable and writable.

6.2.8 IOCD (Pull-high Control Register 2)

Bit 7	Bit 6	Bit 5	Bit 4	Bit 3	Bit 2	Bit 1	Bit 0
-	-	-	-	/PH3	/PH2	/PH1	/PH0

Bits 7 ~ 4: Not used, set to "0" at all time

Bit 3 (/PH3): Control bit used to enable pull-high of the P63 pin.

0 : Enable internal pull-high

1 : Disable internal pull-high

Bit 2 (/PH2): Control bit used to enable pull-high of the P62 pin.

Bit 1 (/PH1): Control bit used to enable pull-high of the P61 pin.

Bit 0 (/PH0): Control bit used to enable pull-high of the P60 pin.

The IOCD Register is both readable and writable.

6.2.9 IOCE (Interrupt Mask Register 2)

Bit 7	Bit 6	Bit 5	Bit 4	Bit 3	Bit 2	Bit 1	Bit 0
-	-	TCIE3	TCIE2	-	-	-	-

Bits 7 ~ 6: Not used, set to "0" at all time

Bit 5 (TCIE3): Interrupt enable bit

0 : Disable TCIF3 interrupt

1 : Enable TCIF3 interrupt

Bit 4 (TCIE2): Interrupt enable bit

0 : Disable TCIF2 interrupt

1 : Enable TCIF2 interrupt

Bits 3 ~ 0: Not used, set to "0" at all time

6.2.10 IOCF (Interrupt Mask Register 1)

Bit 7	Bit 6	Bit 5	Bit 4	Bit 3	Bit 2	Bit 1	Bit 0
CMPIE	ADIE	-	-	-	EXIE	ICIE	TCIE

Bit 7 (CMPIE): Interrupt enable bit

0 : Disable CMPIF interrupt

1 : Enable CMPIF interrupt

Bit 6 (ADIE): ADIF interrupt enable bit

0 : Disable ADIF interrupt

1 : Enable ADIF interrupt

When the ADC Complete is used to enter an interrupt vector or enter next instruction, the ADIE bit must be set to "Enable".

Bits 5 ~ 3: Not used, set to "0" at all time

Bit 2 (EXIE): EXIF interrupt enable bit

0 : Disable EXIF interrupt

1 : Enable EXIF interrupt

Bit 1 (ICIE): ICIF interrupt enable bit

0 : Disable ICIF interrupt

1 : Enable ICIF interrupt

Bit 0 (TCIE): TCIF interrupt enable bit

0 : Disable TCIF interrupt

1 : Enable TCIF interrupt

Individual interrupt is enabled by setting its associated control bit in the IOCF to "1".

Global interrupt is enabled by the ENI instruction and is disabled by the DISI instruction. The IOCF register is both readable and writable.

6.3 TCC/WDT and Prescaler

There are two 8-bit counters available as prescalers for the TCC and WDT respectively. The PST0~PST2 bits of the CONT register are used to determine the ratio of the TCC prescaler. Likewise, the PSW0~PSW2 bits of the IOCA register are used to determine the WDT prescaler. The prescaler counter will be cleared by the instructions each time they are written into TCC. The WDT and prescaler will be cleared by the “WDTC” and “SLEP” instructions. Figure 6-11 depicts the circuit diagram of TCC/WDT.

R1 (TCC) is an 8-bit timer/counter. The TCC clock source can be the internal clock or external signal input (edge selectable from the TCC pin). If the TCC signal source is from the internal clock, the TCC will be incremented by 1 at the Fc clock (without prescaler). As illustrated in Figure 6-11, selection of Fc depends on Bank 0 RE.6 <TIMERSC>. If the TCC signal source is from an external clock input, the TCC will be incremented by 1 at every falling edge or rising edge of the TCC pin. The TCC pin input time length (kept in high or low level) must be greater than 1CLK. The TCC will stop running when sleep mode occurs.

The watchdog timer is a free running on-chip RC oscillator. WDT will keep on running even after the oscillator driver has been turned off (i.e. in sleep mode). During normal operation or sleep mode, a WDT time-out (if enabled) will cause the device to reset. WDT can be enabled or disabled at any time during normal mode by software programming. Refer to WDTE bit of the IOCA register. With no prescaler, the WDT time-out period is approximately 18 ms¹ (one oscillator start-up timer period).

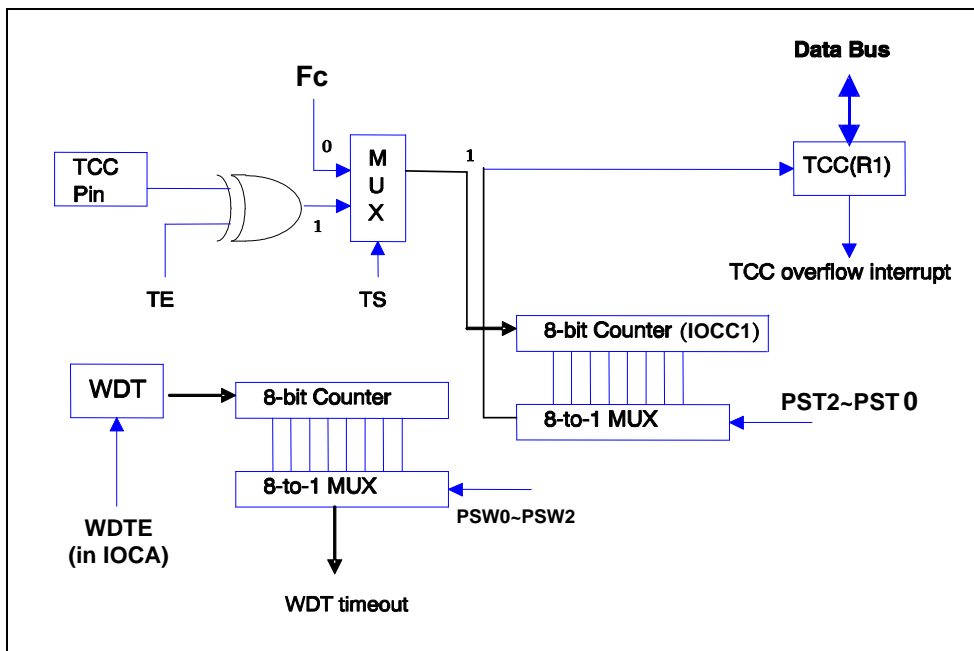

Figure 6-11 Block Diagram of TCC and WDT

¹ VDD=5V, WDT time-out period = 16.5ms ± 5%
VDD=3V, WDT time-out period = 18ms ± 5%.

6.4 I/O Ports

The I/O registers, Ports 5, 6, 7 and 8, are bidirectional tri-state I/O ports. Port 6 / 7 can be pulled high internally by software. In addition, Port 6 can also have open-drain output by software. Input status change interrupt (or wake-up) function on Port 6 P50 ~ P53 and P60 ~ P63 and Port 7 pins can be pulled down by software. Each I/O pin can be defined as "input" or "output" pin by the I/O control register (IOC5 ~ IOC8).

The I/O registers and I/O control registers are both readable and writable. The I/O interface circuits for Port 5, Port 6, Port 7 and Port 8 are shown in the following Figures 6-12, 6-13 (a), 6-13 (b), and Figure 6-14.

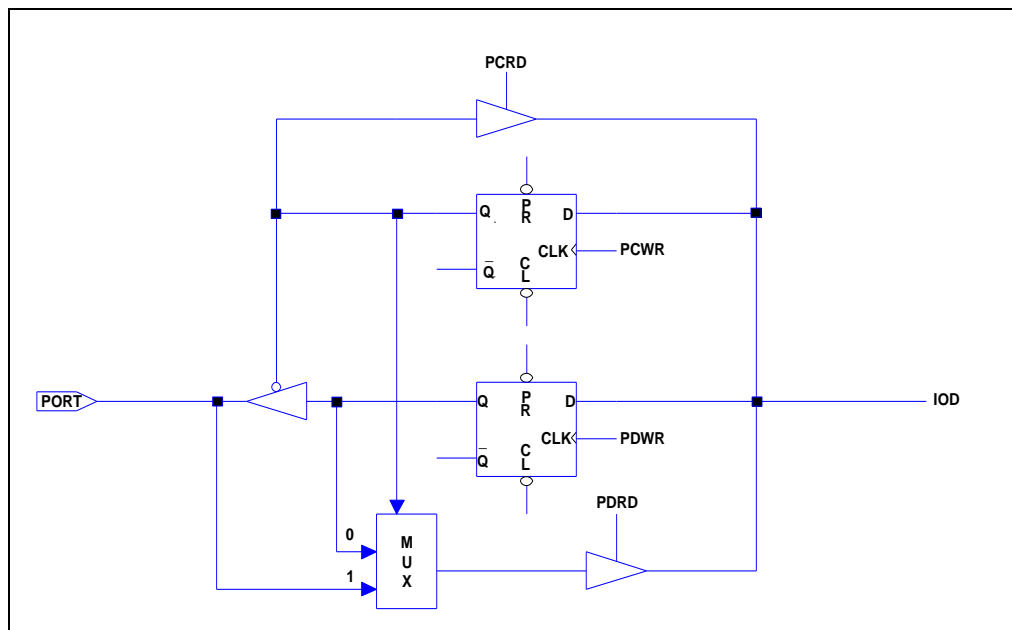

Note: Pull-down is not shown in the figure.

Figure 6-12 I/O Port and I/O Control Register Circuit for Ports 5, 6, 7

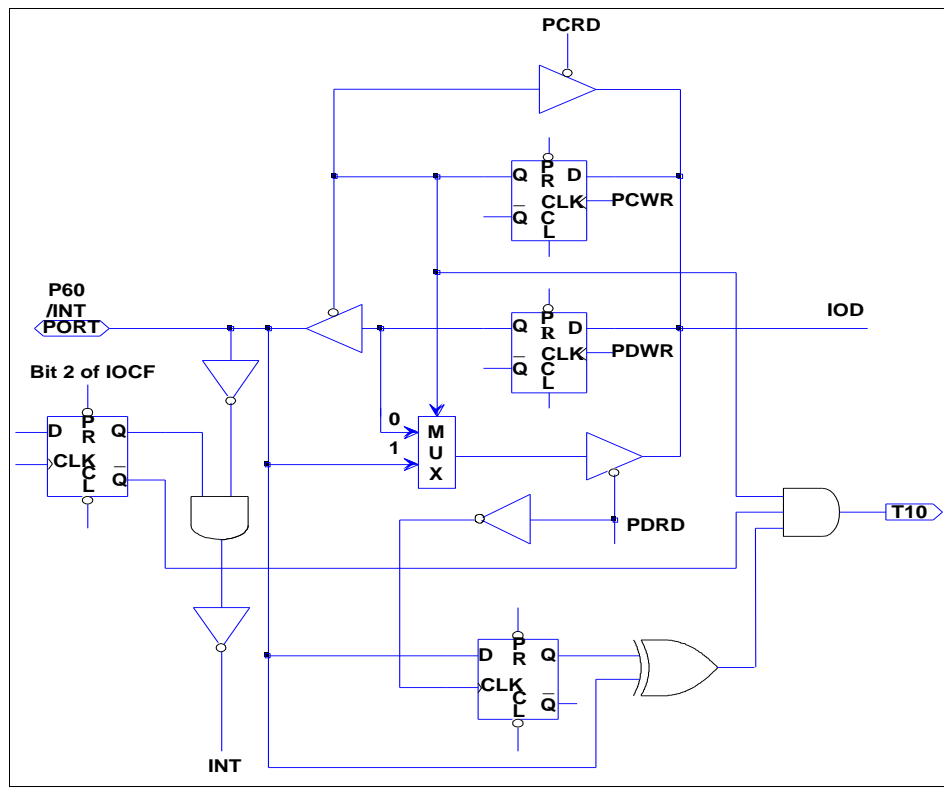

Note: Pull-high (down) and Open-drain are not shown in the figure.

Figure 6-13 (a) I/O Port and I/O Control Register Circuit for P60 (/INT)

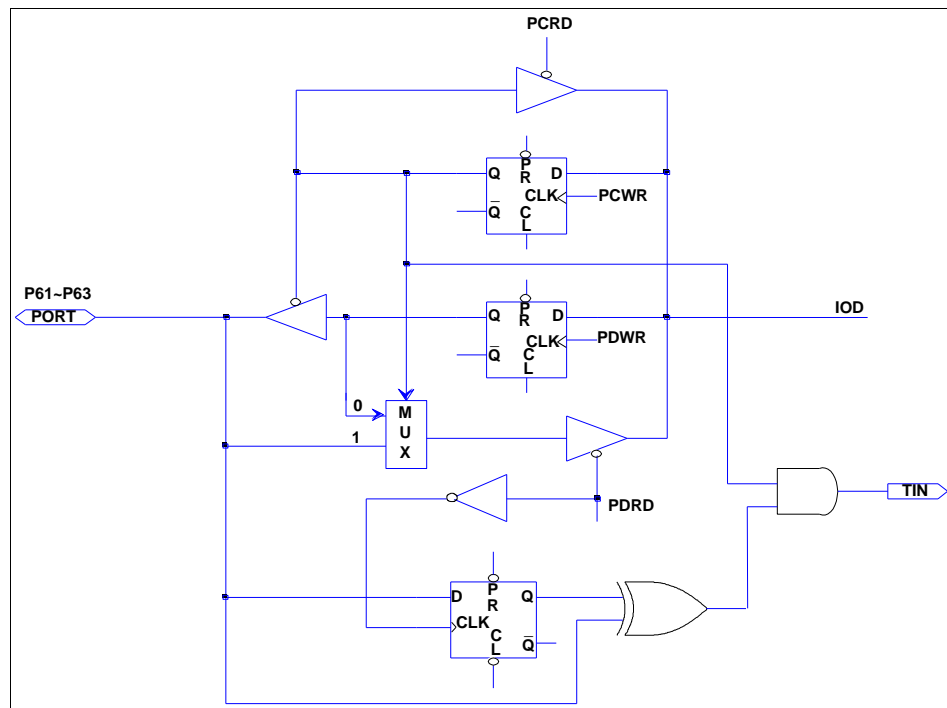

Note: Pull-high (down) and Open-drain are not shown in the figure.

Figure 6-13 (b) I/O Port and I/O Control Register Circuit for P61~P63, P83

6.5 Reset and Wake-up

6.5.1 Reset

A reset is initiated by one of the following events:

- (1) Power-on reset
- (2) /RESET pin input "low"
- (3) WDT time-out (if enabled)

The device is kept in a reset condition for a period of approximately 18ms³ (one oscillator start-up timer period) after the reset is detected. Once a reset occurs, the following functions are performed. Refer to Figure 6-8.

- The oscillator is running, or will be started.
- The Program Counter (R2) is set to all "0".
- All I/O port pins are configured as input mode (high-impedance state).
- The Watchdog Timer and prescaler are cleared.
- When power is switched on, the upper three bits of R3 are cleared.
- The bits of the RB, RC, RD, RD, RE registers are set to their previous status.
- The bits of the CONT register are set to all "0" except for Bit 6 (INT flag).
- The bits of the Pull-high, Pull-down.
- Bank 0 RF, IOCF registers are cleared.

Sleep (power down) mode is asserted by executing the "SLEP" instruction. While entering sleep mode, WDT (if enabled) is cleared but keeps on running. After a wake-up, in RC mode the wake-up time is 34 clocks. High crystal mode wake-up time is 2 ms and 32 clocks. In low Crystal 2 mode, wake-up time is 500 ms.

The controller can be awakened by:

- (1) External reset input on /RESET pin
- (2) WDT time-out (if enabled)
- (3) Port 6 input status changes (if enabled)
- (4) External (P60, /INT) pin changes (if EXWE is enabled)
- (5) A/D conversion completed (if ADWE is enabled)
- (6) Comparator output status change (if CMPWE is enabled)

V_{dd} = 3V, set up time period = 18ms ± 8%

The first two cases will cause the EM78F562N/F662N to reset. The T and P flags of R3 can be used to determine the source of the reset (wake-up). Cases 3 ~ 5 are considered the continuation of program execution and the global interrupt ("ENI" or "DISI" being executed) determines whether or not the controller branches to the interrupt vector following wake-up. If ENI is executed before SLEP, the instruction will begin to execute from Address 0x3, 0x6 0xF, 0x15 or 0X30, after wake-up. If DISI is executed before SLEP, the execution will restart from the instruction right next to SLEP after wake-up. All throughout the sleep mode, wake-up time is 150 μ s, no matter what oscillation mode (except low Crystal mode). In low Crystal 2 mode, wake-up time is 500 ms.

Only one or more of Cases 2 to 5 can be enabled before entering into sleep mode. That is,

- [a] If WDT is enabled before SLEP, all of the RE bit is disabled. Hence, the EM78F562N/F662N can be awakened only by Case 1 or 2. Refer to the Interrupt section for further details.
- [b] If Port 6 Input Status Change is used to wake up the EM78F562N/F662N and the ICWE bit of the RA register is enabled before SLEP, WDT must be disabled. Hence, the EM78F562N/F662N can be awakened only by Case 3.
- [c] If External (P60,/INT) pin changes is used to wake-up the EM78F562N/F662N and EXWE bit of the RA register is enabled before SLEP, WDT must be disabled by software. Hence, the EM78F562N/F662N can be awakened only by Case 4.
- [d] If AD conversion completed is used to wake-up EM78F562N/F662N and ADWE bit of RA register is enabled before SLEP, the WDT must be disabled by software. Hence, the EM78F562N/F662N can be awakened only by Case 5.
- [e] If Comparator output status change is used to wake-up EM78F562N/F662N and CMPWE bit of RA register is enabled before SLEP, WDT must be disabled by software. Hence, the EM78F562N/F662N can be wakened only by Case 6.

If Port 6 Input Status Change Interrupt is used to wake up the EM78F562N/F662N, (as in Case [a] above), the following instructions must be executed before SLEP:

```

MOV          A, @001110xxb ; Select WDT prescaler and Disable
                                   ; WDT
IOW          IOCA
WDTC                                     ; Clear WDT and prescaler
MOV          R6, R6 ; Read Port 6
ENI (or DISI) ; Enable (or disable) global
                                   ; interrupt
MOV          A, @010xxxxxb ; Enable Port 6 input change
                                   ; wake-up bit
MOV          RA,A
MOV          A, @00000x1xb ; Enable Port 6 input change
                                   ; interrupt
IOW          IOCF
SLEP                                     ; Sleep

```

Similarly, if the Comparator Interrupt is used to wake up the EM78F562N/F662N (as in Case [c] above), the following instructions must be executed before SLEEP:

```
Bank          3                ; Select Bank 3

MOV           A, @xxxxxxx10b   ; Select a comparator and P60 act
                                       ; as CO pin

MOV           RB,A
MOV           A, @001110xxb    ; Select WDT prescaler and Disable
                                       ; WDT

IOW           IOCA
WDTC                          ; Clear WDT and prescaler
ENI (or DISI)                 ; Enable (or disable) global
                                       ; interrupt

MOV           A, @xxxxxxx1xb   ; Enable comparator output status
                                       ; change wake-up bit

MOV           RA,A
MOV           A, @10000000b    ; Enable comparator output status
                                       ; change interrupt

IOW           IOCF
SLEEP                          ; Sleep
```

6.5.2 Wake-up

Summary of Wake-up and Interrupt Modes

All categories under Wake-up and Interrupt modes are summarized below.

The controller can be awakened from sleep mode and idle mode. The wake-up signals are listed as follows.

Wake-up Signal	Sleep Mode	Idle Mode	Green Mode	Normal Mode
External interrupt	If EXWE bit is enabled Wake-up + interrupt (if interrupt is enabled) + next instruction	If EXWE bit is enabled Wake-up + interrupt (if interrupt is enabled) + next instruction	Interrupt (if interrupt is enabled) or next instruction	Interrupt (if interrupt is enabled) or next instruction
Port 6 pin change	If enable ICWE bit Wake-up + interrupt (if interrupt is enabled) + next instruction	If enable ICWE bit Wake-up + interrupt (if interrupt is enabled) + next instruction	Interrupt (if interrupt is enabled) or next instruction	Interrupt (if interrupt is enabled) or next instruction
TCC overflow interrupt	x	Wake-up + interrupt (if interrupt is enabled) + next instruction	Interrupt (if interrupt is enabled) or next instruction	Interrupt (if interrupt is enabled) or next instruction
Comparator interrupt	If CMPWE bit is enabled Wake-up + interrupt (if interrupt is enabled) + next instruction	If CMPWE bit is enabled Wake-up + interrupt (if interrupt is enabled) + next instruction	Interrupt (if interrupt is enabled) or next instruction	Interrupt (if interrupt is enabled) or next instruction
AD conversion complete interrupt	If ADWE bit is enabled Wake-up + interrupt (if interrupt is enabled) + next instruction Fs and Fm don't stop	If ADWE bit is enabled Wake-up + interrupt (if interrupt is enabled) + next instruction Fs and Fm don't stop	Interrupt (if interrupt is enabled) or next instruction Fs and Fm don't stop	Interrupt (if interrupt is enabled) or next instruction
TC2 interrupt	x	Wake-up + interrupt (if interrupt is enabled) + next instruction	Interrupt (if interrupt is enabled) or next instruction	Interrupt (if interrupt is enabled) or next instruction
TC3 interrupt	x	Wake-up + interrupt (if interrupt is enabled) + next instruction	Interrupt (if interrupt is enabled) or next instruction	Interrupt (if interrupt is enabled) or next instruction
WDT Time out	RESET	RESET	RESET	RESET
Low Voltage Reset	RESET	RESET	RESET	RESET

After wake up:

1. If interrupt is enabled → interrupt + next instruction
2. If interrupt is disabled → next instruction

6.5.3 Summary of Register Initial Values after Reset

Legend: *U*: Unknown or don't care *P*: Previous value before reset
x: Not used *t*: Check Table 6-2

Addr.	Name	Reset Type	Bit 7	Bit 6	Bit 5	Bit 4	Bit 3	Bit 2	Bit 1	Bit 0
0x05	IOC5	Bit Name	C57	C56	C55	C54	C53	C52	C51	C50
		Power-on	1	1	1	1	1	1	1	1
		/RESET and WDT	1	1	1	1	1	1	1	1
		Wake-up from Pin Change	P	P	P	P	P	P	P	P
0x06	IOC6	Bit Name	x	x	x	x	C63	C62	C61	C60
		Power-on	0	0	0	0	1	1	1	1
		/RESET and WDT	0	0	0	0	1	1	1	1
		Wake-up from Pin Change	0	0	0	0	P	P	P	P
0x07	IOC7	Bit Name	C77	x	x	x	C73	C72	C71	C70
		Power-on	1	0	0	0	1	1	1	1
		/RESET and WDT	1	0	0	0	1	1	1	1
		Wake-up from Pin Change	P	0	0	0	P	P	P	P
0x08	IOC8	Bit Name	x	x	x	x	C83	x	x	x
		Power-on	0	0	0	0	1	0	0	0
		/RESET and WDT	0	0	0	0	1	0	0	0
		Wake-up from Pin Change	0	0	0	0	P	0	0	0
N/A	CONT	Bit Name	INTE	/INT	TS	TE	PSTE	PST2	PST1	PST0
		Power-on	0	0	0	0	0	0	0	0
		/RESET and WDT	0	0	0	0	0	0	0	0
		Wake-up from Pin Change	P	P	P	P	P	P	P	P
0x00	R0 IAR	Bit Name	IAR7	IAR6	IAR5	IAR4	IAR3	IAR2	IAR1	IAR0
		Power-on	U	U	U	U	U	U	U	U
		/RESET and WDT	P	P	P	P	P	P	P	P
		Wake-up from Pin Change	P	P	P	P	P	P	P	P
0x01	R1 TCC	Bit Name	TCC7	TCC6	TCC5	TCC4	TCC3	TCC2	TCC1	TCC0
		Power-on	0	0	0	0	0	0	0	0
		/RESET and WDT	0	0	0	0	0	0	0	0
		Wake-up from Pin Change	P	P	P	P	P	P	P	P
0x02	R2 PC	Bit Name	A7	A6	A5	A4	A3	A2	A1	A0
		Power-on	0	0	0	0	0	0	0	0
		/RESET and WDT	0	0	0	0	0	0	0	0
		Wake-up from Pin Change	P	P	P	P	P	P	P	P
0x03	R3 SR	Bit Name	x	x	x	T	P	Z	DC	C
		Power-on	0	0	0	1	1	U	U	U
		/RESET and WDT	0	0	0	t	t	P	P	P
		Wake-up from Pin Change	0	0	0	t	t	P	P	P
0x04	R4 RSR	Bit Name	RSR7	RSR6	RSR5	RSR4	RSR3	RSR2	RSR1	RSR0
		Power-on	U	U	U	U	U	U	U	U
		/RESET and WDT	P	P	P	P	P	P	P	P
		Wake-up from Pin Change	P	P	P	P	P	P	P	P



(Continuation)

Addr.	Name	Reset Type	Bit 7	Bit 6	Bit 5	Bit 4	Bit 3	Bit 2	Bit 1	Bit 0
0x05	Bank 0 P5	Bit Name	P57	P56	P55	P54	P53	P52	P51	P50
		Power-on	1	1	1	1	1	1	1	1
		/RESET and WDT	1	1	1	1	1	1	1	1
		Wake-up from Pin Change	P	P	P	P	P	P	P	P
0x06	Bank 0 P6	Bit Name	x	x	x	x	P63	P62	P61	P60
		Power-on	0	0	0	0	1	1	1	1
		/RESET and WDT	0	0	0	0	1	1	1	1
		Wake-up from Pin Change	0	0	0	0	P	P	P	P
0x07	Bank 0 P7	Bit Name	P77	x	x	x	P73	P72	P71	P70
		Power-on	1	0	0	0	1	1	1	1
		/RESET and WDT	1	0	0	0	1	1	1	1
		Wake-up from Pin Change	P	0	0	0	P	P	P	P
0x08	Bank 0 P8	Bit Name	x	x	x	x	P83	x	x	x
		Power-on	0	0	0	0	1	0	0	0
		/RESET and WDT	0	0	0	0	1	0	0	0
		Wake-up from Pin Change	0	0	0	0	P	0	0	0
0x09	Bank 0 R9 TBPTL	Bit Name	RBit7	RBit6	RBit5	RBit4	RBit3	RBit2	RBit1	RBit0
		Power-on	0	0	0	0	0	0	0	0
		/RESET and WDT	0	0	0	0	0	0	0	0
		Wake-up from Pin Change	P	P	P	P	P	P	P	P
0x0A	Bank 0 RA WUCR	Bit Name	x	ICWE	ADWE	EXWE	x	x	CMPWE	x
		Power-on	0	0	0	0	0	0	0	0
		/RESET and WDT	0	0	0	0	0	0	0	0
		Wake-up from Pin Change	0	P	P	P	0	0	0	0
0x0B	Bank 0 RB ECR	Bit Name	RD	WR	EEWE	EEDF	EEPC	x	x	x
		Power-on	0	0	0	0	0	0	0	0
		/RESET and WDT	P	P	P	P	P	0	0	0
		Wake-up from Pin Change	P	P	P	P	P	0	0	0
0x0C	Bank 0 RC EA	Bit Name	x	EE_A6	EE_A5	EE_A4	EE_A3	EE_A2	EE_A1	EE_A0
		Power-on	0	0	0	0	0	0	0	0
		/RESET and WDT	0	P	P	P	P	P	P	P
		Wake-up from Pin Change	0	P	P	P	P	P	P	P
0x0D	Bank 0 RD ED	Bit Name	EE_D7	EE_D6	EE_D5	EE_D4	EE_D3	EE_D2	EE_D1	EE_D0
		Power-on	0	0	0	0	0	0	0	0
		/RESET and WDT	P	P	P	P	P	P	P	P
		Wake-up from Pin Change	P	P	P	P	P	P	P	P
0x0E	Bank 0 RE CPUOCR	Bit Name	x	TIMERSC	CPUS	IDLE	x	x	x	x
		Power-on	0	1	1	1	0	0	0	0
		/RESET and WDT	0	1	1	1	0	0	0	0
		Wake-up from Pin Change	0	P	P	P	0	0	0	0

(Continuation)

Addr	Name	Reset Type	Bit 7	Bit 6	Bit 5	Bit 4	Bit 3	Bit 2	Bit 1	Bit 0
0x0F	Bank 0 RF ISR	Bit Name	CMPIF	ADIF	x	x	x	EXIF	ICIF	TCIF
		Power-on	0	0	0	0	0	0	0	0
		/RESET and WDT	0	0	0	0	0	0	0	0
		Wake-up from Pin Change	P	P	0	0	0	P	P	P
0x8	Bank 1 R8 TC2CR	Bit Name	RCM1	RCM0	TC2ES	TC2M	TC2S	TC2CK2	TC2CK1	TC2CK0
		Power-on	Option RCM1	Option RCM0	0	0	0	0	0	0
		/RESET and WDT	Option RCM1	Option RCM0	0	0	0	0	0	0
		Wake-up from Pin Change	P	P	P	P	P	P	P	P
0x9	Bank 1 R9 TC2DH	Bit Name	TC2D15	TC2D14	TC2D13	TC2D12	TC2D11	TC2D10	TC2D9	TC2D8
		Power-on	0	0	0	0	0	0	0	0
		/RESET and WDT	0	0	0	0	0	0	0	0
		Wake-up from Pin Change	P	P	P	P	P	P	P	P
0xA	Bank 1 RA TC2DL	Bit Name	TC2D7	TC2D6	TC2D5	TC2D4	TC2D3	TC2D2	TC2D1	TC2D0
		Power-on	0	0	0	0	0	0	0	0
		/RESET and WDT	0	0	0	0	0	0	0	0
		Wake-up from Pin Change	P	P	P	P	P	P	P	P
0xF	Bank 1 RF ISR	Bit Name	x	x	TCIF3	TCIF2	x	x	x	x
		Power-on	0	0	0	0	0	0	0	0
		/RESET and WDT	0	0	0	0	0	0	0	0
		Wake-up from Pin Change	0	0	0	0	0	0	0	0
0x05	R5 (Bank 2)	Bit Name	ADE7	ADE6	ADE5	ADE4	ADE3	ADE2	ADE1	ADE0
		Power-on	0	0	0	0	0	0	0	0
		/RESET and WDT	0	0	0	0	0	0	0	0
		Wake-up from Pin Change	P	P	P	P	P	P	P	P
0x06	Bank 2 R6 ADCON	Bit Name	VREFS	CKR1	CKR0	ADRUN	ADPD	ADIS2	ADIS1	ADIS0
		Power-on	0	0	0	0	0	0	0	0
		/RESET and WDT	0	0	0	0	0	0	0	0
		Wake-up from Pin Change	P	P	P	P	P	P	P	P
0x7	Bank 2 R7 ADOC	Bit Name	CALI	SIGN	VOF[2]	VOF[1]	VOF[0]	x	x	x
		Power-on	0	0	0	0	0	0	0	0
		/RESET and WDT	0	0	0	0	0	0	0	0
		Wake-up from Pin Change	P	P	P	P	P	0	0	0
0x8	Bank 2 R8 ADDH	Bit Name	ADD9	ADD8	ADD7	ADD6	ADD5	ADD4	ADD3	ADD2
		Power-on	0	0	0	0	0	0	0	0
		/RESET and WDT	0	0	0	0	0	0	0	0
		Wake-up from Pin Change	P	P	P	P	P	P	P	P



(Continuation)

Addr.	Name	Reset Type	Bit 7	Bit 6	Bit 5	Bit 4	Bit 3	Bit 2	Bit 1	Bit 0
0x9	Bank 2 R9 ADDL	Bit Name	x	x	x	x	x	x	ADD1	ADD0
		Power-on	0	0	0	0	0	0	0	0
		/RESET and WDT	0	0	0	0	0	0	0	0
		Wake-up from Pin Change	0	0	0	0	0	0	0	P
0x0B	Bank 2 RB CMPCON	Bit Name	x	x	x	x	x	CPOUT	CPS1	CPS0
		Power-on	0	0	0	0	0	0	0	0
		/RESET and WDT	0	0	0	0	0	0	0	0
		Wake-up from Pin Change	0	0	0	0	0	0	P	P
0x0F	Bank 2 RF PHCR1	Bit Name	x	x	x	x	/PH73	/PH72	/PH71	/PH70
		Power-on	0	0	0	0	1	1	1	1
		/RESET and WDT	0	0	0	0	1	1	1	1
		Wake-up from Pin Change	0	0	0	0	P	P	P	P
0x06	Bank 3 R6 TBPTH	Bit Name	MLB	x	x	x	x	RBit 10	RBit 9	RBit 8
		Power-on	0	0	0	0	0	0	0	0
		/RESET and WDT	0	0	0	0	0	0	0	0
		Wake-up from Pin Change	P	0	0	0	0	P	P	P
0xD	Bank 3 RD TC3CR	Bit Name	TC3FF1	TC3FF0	TC3S	TC3CK2	TC3CK1	TC3CK0	TC3M1	TC3M0
		Power-on	0	0	0	0	0	0	0	0
		/RESET and WDT	0	0	0	0	0	0	0	0
		Wake-up from Pin Change	P	P	P	P	P	P	P	P
0xE	Bank 3 RE TC3D	Bit Name	TC3D7	TC3D6	TC3D5	TC3D4	TC3D3	TC3D2	TC3D1	TC3D0
		Power-on	0	0	0	0	0	0	0	0
		/RESET and WDT	0	0	0	0	0	0	0	0
		Wake-up from Pin Change	P	P	P	P	P	P	P	P
0xF	Bank 3 RF PDCR1	Bit Name	x	x	x	x	/PD73	/PD72	/PD71	/PD70
		Power-on	0	0	0	0	1	1	1	1
		/RESET and WDT	0	0	0	0	1	1	1	1
		Wake-up from Pin Change	0	0	0	0	P	P	P	P
0x0A	IOCA WDTCR	Bit Name	WDTE	EIS	x	x	PSWE	PSW2	PSW1	PSW0
		Power-on	0	0	0	0	0	0	0	0
		/RESET and WDT	0	0	0	0	0	0	0	0
		Wake-up from Pin Change	P	P	0	0	P	P	P	P
0x0B	IOCB PDCR2	Bit Name	/PD7	/PD6	/PD5	/PD4	/PD3	/PD2	/PD1	/PD0
		Power-on	1	1	1	1	1	1	1	1
		/RESET and WDT	1	1	1	1	1	1	1	1
		Wake-up from Pin Change	P	P	P	P	P	P	P	P
0x0C	IOCC ODCR	Bit Name	x	x	x	x	OD3	OD2	OD1	OD0
		Power-on	0	0	0	0	0	0	0	0
		/RESET and WDT	0	0	0	0	0	0	0	0
		Wake-up from Pin Change	0	0	0	0	P	P	P	P

(Continuation)

Addr	Name	Reset Type	Bit 7	Bit 6	Bit 5	Bit 4	Bit 3	Bit 2	Bit 1	Bit 0
0x0D	IOCD PHCR2	Bit Name	x	x	x	x	/PH3	/PH2	/PH1	/PH0
		Power-on	0	0	0	0	1	1	1	1
		/RESET and WDT	0	0	0	0	1	1	1	1
		Wake-up from Pin Change	0	0	0	0	P	P	P	P
0x0E	IOCE IMR2	Bit Name	x	x	TCIE3	TCIE2	x	x	x	x
		Power-on	0	0	0	0	0	0	0	0
		/RESET and WDT	0	0	0	0	0	0	0	0
		Wake-up from Pin Change	0	0	P	P	0	0	0	0
0x0F	IOCF IMR1	Bit Name	CMPIE	ADIE	x	x	x	EXIE	ICIE	TCIE
		Power-on	0	0	0	0	0	0	0	0
		/RESET and WDT	0	0	0	0	0	0	0	0
		Wake-up from Pin Change	P	P	0	0	0	P	P	P
0x10 ~ 0x2F	R10 ~ R2F	Bit Name	R7	R6	R5	R4	R3	R2	R1	R0
		Power-on	U	U	U	U	U	U	U	U
		/RESET and WDT	P	P	P	P	P	P	P	P
		Wake-up from Pin Change	P	P	P	P	P	P	P	P

6.5.4 Status of RST, T, and P of the Status Register

A reset condition is initiated by the following events:

1. Power-on condition
2. High-low-high pulse on the /RESET pin
3. Watchdog timer time-out

The values of T and P, listed in Table 6-2 are used to check how the processor wakes up. Table 6-3 shows the events that may affect the status of T and P.

Table 6-2 Values of RST, T and P after Reset

Reset Type	T	P
Power on	1	1
/RESET during Operating mode	*P	*P
/RESET wake-up during Sleep mode	1	0
WDT during Operating mode	0	*P
WDT wake-up during Sleep mode	0	0
Wake-up on pin change during Sleep mode	1	0

* P: Previous status before reset

Table 6-3 Status of T and P Being Affected by Events

Event	T	P
Power on	1	1
WDTC instruction	1	1
WDT time-out	0	*P
SLEP instruction	1	0
Wake-up on pin change during Sleep mode	1	0

* P: Previous value before reset

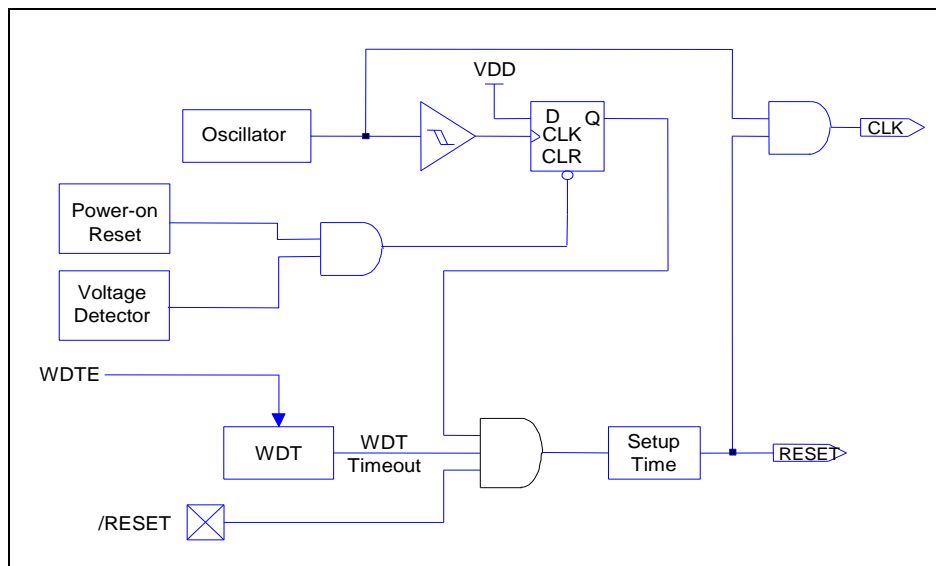

Figure 6-15 Controller Reset Block Diagram

6.6 Interrupt

The EM78F562N/F662N/562N has seven interrupts (three external, four internal) as listed below:

Interrupt Source	Enable Condition	Int. Flag	Int. Vector	Priority	
Internal / External	Reset	-	-	0000	High 0
External	INT	ENI + EXIE=1	EXIF	0003	1
External	Port 6 pin change	ENI + ICIE=1	ICIF	0006	2
Internal	TCC	ENI + TCIE=1	TCIF	0009	3
Internal	TC2	ENI + TCIE2=1	TCIF2	0024	4
Internal	TC3	ENI + TCIE3=1	TCIF3	0027	5
Internal	AD	ENI + ADIE=1	ADIF	0030	6
External	Comparator	ENI + CMPIE=1	CMPIF	0033	7

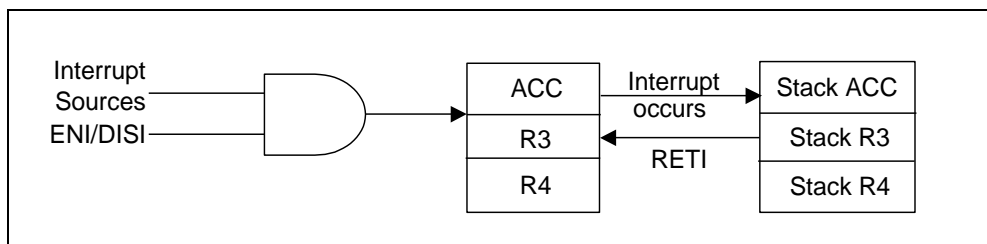

Figure 6-17 Interrupt Back-up Diagram

6.7 Data EEPROM (only for EM78F662N)

The Data EEPROM is readable and writable during normal operation over the whole V_{dd} range. The operation for Data EEPROM is based on a single byte. A write operation makes an erase-then-write cycle to take place on the allocated byte.

The Data EEPROM memory provides high erase and write cycles. A byte write automatically erases the location and writes the new value.

6.7.1 Data EEPROM Control Register

6.7.1.1 RB (EEPROM Control Register)

The EECR (EEPROM Control Register) is the control register for configuring and initiating the control register status.

Bit 7	Bit 6	Bit 5	Bit 4	Bit 3	Bit 2	Bit 1	Bit 0
RD	WR	EEWE	EEDF	EEPC	-	-	-

Bit 7: Read control register

- 0** : Does not execute EEPROM read
- 1** : Read EEPROM content, (RD can be set by software, and is cleared by hardware after Read instruction is completed).

Bit 6: Write control register

- 0** : Write cycle to the EEPROM is completed.
- 1** : Initiate a write cycle, (WR can be set by software, and is cleared by hardware after Write cycle is completed).

Bit 5: EEPROM Write Enable bit

- 0** : Prohibit write to the EEPROM
- 1** : Allows EEPROM write cycles

Bit 4: EEPROM Detect Flag

- 0** : Write cycle is completed
- 1** : Write cycle is unfinished

Bit 3: EEPROM power-down control bit

- 0** : Switch off the EEPROM
- 1** : EEPROM is operating

Bits 2 ~ 0: Not used, set to "0" at all time.

6.7.1.2 RC (128 Bytes EEPROM Address)

When accessing the EEPROM data memory, RC (128 bytes EEPROM address register) holds the address to be accessed. In accordance with the operation, RD (128 bytes EEPROM Data register) holds the data to be written, or the data read, at the address in RC.

Bit 7	Bit 6	Bit 5	Bit 4	Bit 3	Bit 2	Bit 1	Bit 0
-	EE_A6	EE_A5	EE_A4	EE_A3	EE_A2	EE_A1	EE_A0

Bit 7: Not used, set to “0” at all time.

Bits 6 ~ 0: 128 bytes EEPROM address

6.7.1.3 RD (256 Bytes EEPROM Data)

Bit 7	Bit 6	Bit 5	Bit 4	Bit 3	Bit 2	Bit 1	Bit 0
EE_D7	EE_D6	EE_D5	EE_D4	EE_D3	EE_D2	EE_D1	EE_D0

Bits 7 ~ 0: 128 bytes EEPROM data

6.7.2 Programming Step / Example Demonstration

6.7.2.1 Programming Step

Follow these steps to write or read data from the EEPROM:

- (1) Set the RB.EEPC bit to “1” to enable the EEPROM power.
- (2) Write the address to RC (128 bytes EEPROM address).
 - a.1. Set the RB.EEWE bit to “1”, if the write function is employed.
 - a.2. Write the 8-bit data value to be programmed in the RD (256 bytes EEPROM data)
 - a.3. Set the RB.WR bit to “1”, then execute write function
 - b. Set the RB.READ bit to “1”, after which, execute read function
- (3)
 - a. Wait for the RB.EEDF or RB.WR to be cleared
 - b. Wait for the RB.EEDF to be cleared
- (4) For the next conversion, go to Step 2 as required.
- (5) If user wants to conserve power and to make sure the EEPROM data is not used, clear the RB.EEPC.

6.7.2.2 Example Demonstration Programs

```

; To define the control register
; Write data to EEPROM
RC == 0x0C
RB == 0x0B
RD == 0x0D
Read == 0x07
WR == 0x06
EEWE == 0x05
EEDF == 0x04
EEPC == 0x03
    
```

```

BS RB, EEPC      ; Set the EEPROM to power on
MOV A,@0x0A
MOV RC,A        ; Assign the address from EEPROM
BS RB, EEWE     ; Enable the EEPROM write function
MOV A,@0x55
MOV RD,A       ; Set the data for EEPROM
BS RB,WR       ; Write value to EEPROM
JBC RB,EEDF    ; To check the EEPROM bit whether complete or not
JMP $-1
    
```

6.8 Analog-to-Digital Converter (ADC)

The analog-to-digital circuitry consists of an 8-bit analog multiplexer, three control registers [AISR/R5 (Bank 2), ADCON/R6 (Bank 2), and ADOC/R7 (Bank 2)], two data registers (ADDH, ADDL/R8, R9) and an ADC with 10-bit resolution. The functional block diagram of the ADC is shown in Figure 6-18. The analog reference voltage (V_{ref}) and analog ground are connected via separate input pins.

The ADC module utilizes successive approximation to convert the unknown analog signal into a digital value. The result is fed to the ADDH and ADDL. Input channels are selected by the analog input multiplexer via the ADCON register Bits ADIS2, ADIS1 and ADIS0.

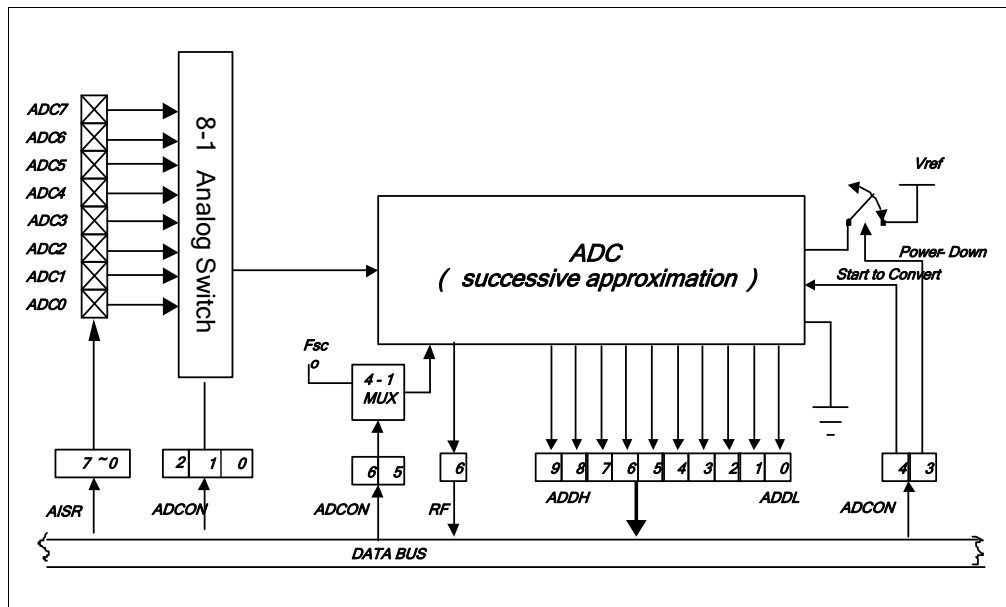

Figure 6-18 Functional Block Diagram of Analog-to-Digital Conversion

6.8.1 ADC Control Register (AISR/R5, ADCON/R6, ADOC/R7)

6.8.1.1 Bank 2 R5 AISR (ADC Input Select Register)

The AISR register individually defines the ADC pins as analog input or as digital I/O.

Bit 7	Bit 6	Bit 5	Bit 4	Bit 3	Bit 2	Bit 1	Bit 0
ADE7	ADE6	ADE5	ADE4	ADE3	ADE2	ADE1	ADE0

Bit 7 (ADE7): AD converter enable bit of the P57 pin.

0 : Disable ADC7, P57 act as I/O pin.

1 : Enable ADC7 to act as analog input pin

Bit 6 (ADE6): AD converter enable bit of the P56 pin.

0 : Disable ADC6, P56 act as I/O pin

1 : Enable ADC6 to act as analog input pin

Bit 5 (ADE5): AD converter enable bit of the P77 pin

0 : Disable ADC5, P77 functions as I/O pin

1 : Enable ADC5 to function as analog input pin

Bit 4 (ADE4): AD converter enable bit of the P73 pin

0 : Disable ADC4, P73 act as I/O pin

1 : Enable ADC4 to act as analog input pin

Bit 3 (ADE3): AD converter enable bit of the P63 pin.

0 : Disable ADC3, P63 act as I/O pin

1 : Enable ADC3 to act as analog input pin

Bit 2 (ADE2): AD converter enable bit of the P62 pin.

0 : Disable ADC2, P62 act as I/O pin

1 : Enable ADC2 to act as analog input pin

Bit 1 (ADE1): AD converter enable bit of the P61 pin

0 : Disable ADC1, P61 functions as I/O pin

1 : Enable ADC1 to function as analog input pin

Bit 0 (ADE0): AD converter enable bit of the P60 pin

0 : Disable ADC0, P60 act as I/O pin

1 : Enable ADC0 to act as analog input pin

The following table shows the priority of P60/ADC0//INT.

P60/ADC0//Int Pin Priority		
Hight	Medium	Low
/INT	AD0	P60

6.8.1.2 Bank 2 R6 ADCON (A/D Control Register)

The ADCON register controls the operation of the A/D conversion and determines which pin should be currently active.

Bit 7	Bit 6	Bit 5	Bit 4	Bit 3	Bit 2	Bit 1	Bit 0
VREFS	CKR1	CKR0	ADRUN	ADPD	ADIS2	ADIS1	ADIS0

Bit 7 (VREFS): The input source of the Vref of the ADC.

0 : Vref of the ADC is connected to Vdd (default value), and the P50/VREF pin carries out the function of P50

1 : Vref of the ADC is connected to P50/VREF

Bit 6 ~ Bit 5 (CKR1 ~ CKR0): The prescaler of the oscillator clock rate of ADC

CKR1/CKR0	Operation Mode	Max. Operation Frequency
00	$F_{osc}/4$	4 MHz
01	F_{osc}	1 MHz
10	$F_{osc}/16$	16 MHz
11	$F_{osc}/2$	2 MHz

Bit 4 (ADRUN): ADC starts to run

0 : Reset upon completion of AD conversion. This bit cannot be reset by software.

1 : A/D conversion is started. This bit can be set by software.

Bit 3 (ADPD): ADC Power-down mode

0 : Switch off the resistor reference to conserve power even while the CPU is operating

1 : ADC is operating

Bits 2 ~ 0 (ADIS2 ~ ADIS0): AD Input Select Bits

ADIS2	ADIS1	ADIS0	AD Input Pin
0	0	0	AD0
0	0	1	AD1
0	1	0	AD2
0	1	1	AD3
1	0	0	AD4
1	0	1	AD5
1	1	0	AD6
1	1	1	AD7

6.8.1.3 Bank 2 R7 ADOC (A/D Offset Calibration Register)

Bit 7	Bit 6	Bit 5	Bit 4	Bit 3	Bit 2	Bit 1	Bit 0
CALI	SIGN	VOF[2]	VOF[1]	VOF[0]	-	-	-

Bit 7 (CALI): Calibration enable bit for A/D offset

- 0 : Calibration disable
- 1 : Calibration enable

Bit 6 (SIGN): Polarity bit of offset voltage

- 0 : Negative voltage
- 1 : Positive voltage

Bit 5 ~ Bit 3 (VOF[2] ~ VOF[0]): Offset voltage bits

VOF[2]	VOF[1]	VOF[0]	Offset
0	0	0	0 LSB
0	0	1	1 LSB
0	1	0	2 LSB
0	1	1	3 LSB
1	0	0	4 LSB
1	0	1	5 LSB
1	1	0	6 LSB
1	1	1	7 LSB

Bit 2 ~ Bit 0: Not used, set to "0" at all time.

6.8.2 ADC Data Buffer (ADDH, ADDL/R8, R9)

When A/D conversion is completed, the result is loaded to the ADDH, ADDL. The ADRUN bit is cleared, and the ADIF is set.

6.8.3 A/D Sampling Time

The accuracy, linearity, and speed of the successive approximation A/D converter are dependent on the properties of the ADC and the comparator. The source impedance and the internal sampling impedance directly affect the time required to charge the sample holding capacitor. The application program controls the length of the sample time to meet the specified accuracy. Generally speaking, the program should wait for 2 μ s for each K Ω of the analog source impedance and at least 2 μ s for the low-impedance source. The recommended maximum impedance for the analog source is 10 K Ω at V_{dd}=5V. After the analog input channel is selected, this acquisition time must be done before conversion can be started.

6.8.4 A/D Conversion Time

CKR0 and CKR1 select the conversion time (Tct), in terms of instruction cycles. This allows the MCU to run at a maximum frequency without sacrificing the accuracy of A/D conversion. For the EM78F562N/F662N, the conversion time per bit is 1 μ s. Table 6-5 shows the relationship between Tct and the maximum operating frequencies.

Table 6-5 Tct vs. Maximum Operating Frequency

CKR0: CKR1	Operation Mode	Max. Operating Frequency	Max. Conversion Rate Per Bit	Max. Conversion Rate (10-bit)
00	Fosc/4	4 MHz	4 MHz (1 μ s)	(10+9)*1 μ s=19 μ s (52.6kHz)
01	Fosc	1 MHz	1 MHz (1 μ s)	(10+9)*1 μ s=19 μ s (52.6kHz)
10	Fosc/16	16 MHz	16 MHz (1 μ s)	(10+9)*1 μ s=19 μ s (52.6kHz)
11	Fosc/2	2 MHz	2 MHz (1 μ s)	(10+9)*1 μ s=19 μ s (52.6kHz)

AD conversion time (10 bits): 3 fsys (DGD) + 1.5 A/D (DGD) + 4A/D (AMD) + 10A/D (AMD)

NOTE

*The pin not used as an analog input pin can be used as regular input or output pin.
During conversion, do not perform output instruction to maintain precision for all of the pins.*

6.8.5 A/D Operation during Sleep Mode

In order to obtain a more accurate ADC value and reduced power consumption, the A/D conversion remains operational during sleep mode. As the SLEP instruction is executed, all the MCU operations will stop except for the Oscillator, TCC, TC2, TC3, and A/D conversion.

The AD Conversion is considered completed when:

- 1 ADRUN Bit of R6 Register Is cleared to "0".
- 2 Wake-up from A/D Conversion remains in operation during Sleep Mode.

The result is fed to the ADDATA, ADOC when conversion is completed. If the ADWE is enabled, the device will wake up. Otherwise, A/D conversion will be shut off, no matter what the status of the ADPD bit is.

6.8.6 Programming Steps/Considerations

6.8.6.1 Programming Steps

Follow the subsequent steps to obtain data from the ADC:

1. Write to the 8 bits (ADE7 ~ ADE0) on the R5 (AISR) register to define the characteristics of R6: Digital I/O, analog channels, and voltage reference pin.
2. Write to the R6/ADCON register to configure the AD module:
 - a. Select the A/D input channel (ADIS1 ~ ADIS0).
 - b. Define the A/D conversion clock rate (CKR1 ~ CKR0).
 - c. Select the input source of the VREFS of the ADC.
 - d. Set the ADPD bit to 1 to begin sampling.
3. Set the ADWE bit, if wake-up function is employed.
4. Set the ADIE bit, if interrupt function is employed.
5. Put "ENI" instruction, if interrupt function is employed.
6. Set the ADRUN bit to 1.
7. Wait for wake-up or when ADRUN bit is cleared to "0".
8. Read ADDATA, ADOC the conversion data register.
9. Clear the interrupt flag bit (ADIF) when A/D interrupt function has occurred.
10. For the next conversion, go to Step 1 or Step 2 as required. At least two Tct is required before the next acquisition starts.

NOTE

To obtain an accurate value, it is necessary to avoid any data transition on the I/O pins during AD conversion.

6.8.6.2 Demonstration Programs

; To define the general registers

```
R_0 == 0 ; Indirect addressing register
PSW == 3 ; Status register
PORT5 == 5
PORT6 == 6
RE == 0XE ; wake-up control register
RF == 0XF ; Interrupt status register
```

; To define the control register

```
IOC50 == 0X5 ; Control Register of Port 5
IOC60 == 0X6 ; Control Register of Port 6
C_INT == 0XF ; Interrupt Control Register
```



```
;ADC Control Registers
ADDATA == 0x8 ; The contents are the results of ADC
AISR == 0x08 ; ADC output select register
ADCON == 0x6 ; 7 6 5 4 3 2 1 0
                VREFS CKR1 CKR0 ADRUN ADPD
                - ADIS1 ADIS0

;To define bits
;In ADCON
ADRUN == 0x4 ; ADC is executed as the bit is set
ADPD == 0x3 ; Power Mode of ADC

ORG 0 ; Initial address
JMP INITIAL
ORG 0x30 ; Interrupt vector
(User program)
CLR RF ; To clear the ADIF bit
BS ADCON , ADRUN ; To start to execute the next AD
                ; conversion if necessary

RETI

INITIAL:
MOV A , @0B00000001 ; To define P60 as an analog input
MOV AISR , A
MOV A , @0B00001000 ; To select P60 as an analog input
                ; channel, and AD power on
MOV ADCON , A ; To define P60 as an input pin and
                ; set the clock rate at fosc/16

En_ADC:
MOV A , @0BXXXXXX1 ; To define P60 as an input pin, and
                ; the others are dependent
IOW PORT6 ; on applications
MOV A , @0BXXXX1XXX ; Enable the ADWE wake-up function
                ; of ADC, "X" by application

MOV RE , A
MOV A , @0BXXXX1XXX ; Enable the ADIE interrupt function
                ; of ADC, "X" by application

IOW C_INT

ENI ; Enable the interrupt function
BS ADCON , ADRUN ; Start to run the ADC
                ; If the interrupt function is
                ; employed, the following three lines
                ; may be ignored

POLLING:
JBC ADCON , ADRUN ; To check the ADRUN bit
                ; continuously;
JMP ; ADRUN bit will be reset as the AD
POLLING ; conversion is completed
(User program)
```

6.9 Timer/Counter 2

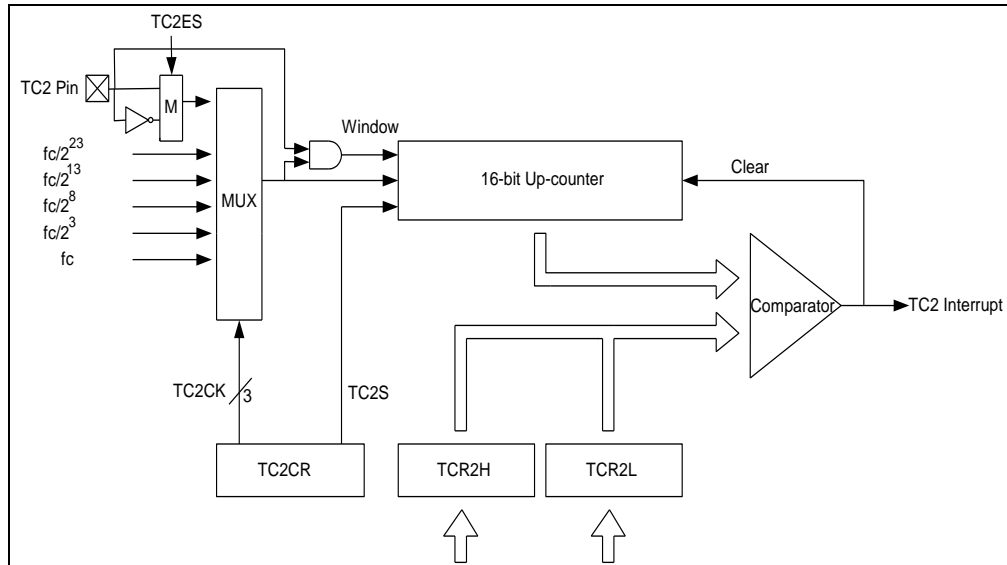

Figure 6-19 Timer / Counter 2 Configuration

In Timer mode, counting up is performed using the internal clock. When the contents of the up-counter match the TCR2 (TCR2H+TCR2L), interrupt is generated and the counter is cleared. Counting up resumes after the counter is cleared.

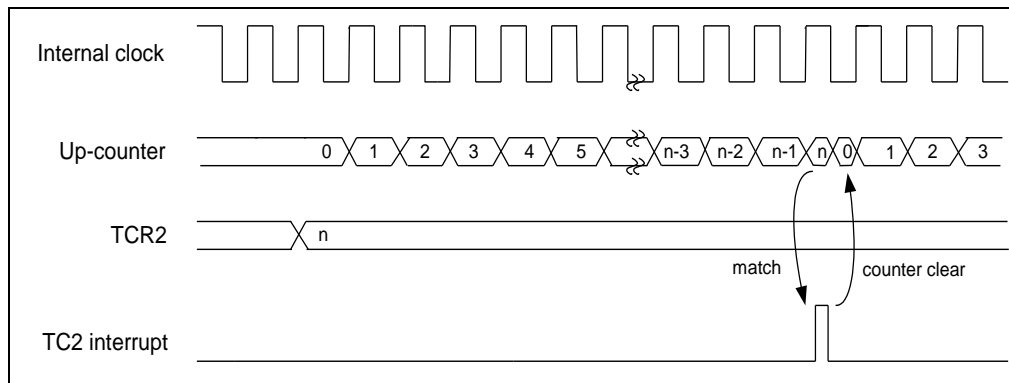

Figure 6-20 Timer Mode Timing Chart

In Counter mode, counting up is performed using external clock input pin (TC2 pin) and either rising or falling can be selected by setting TC2ES. When the contents of the up-counter match the TCR2 (TCR2H+TCR2L), interrupt is generated and the counter is cleared. Counting up resumes after the counter is cleared.

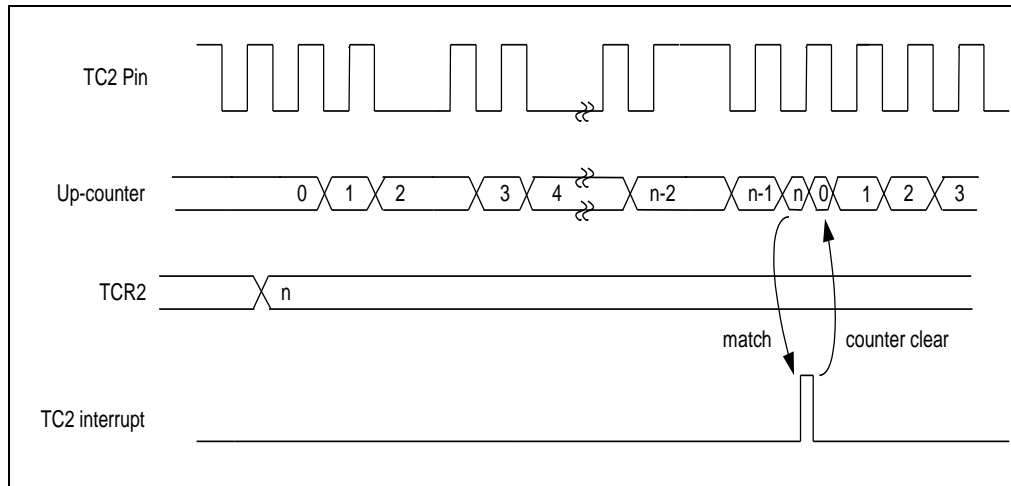

Figure 6-21 Counter Mode Timing Chart ($INT2ES = 1$)

In Window mode, counting up is performed on a rising edge of the pulse that is logical AND of an internal clock and the TC2 pin (window pulse). When the contents of the up-counter match the TCR2 ($TCR2H+TCR2L$), interrupt is generated and the counter is cleared. The frequency (window pulse) must be slower than the selected internal clock.

While writing to the TCR2L, comparison is inhibited until TCR2H is written.

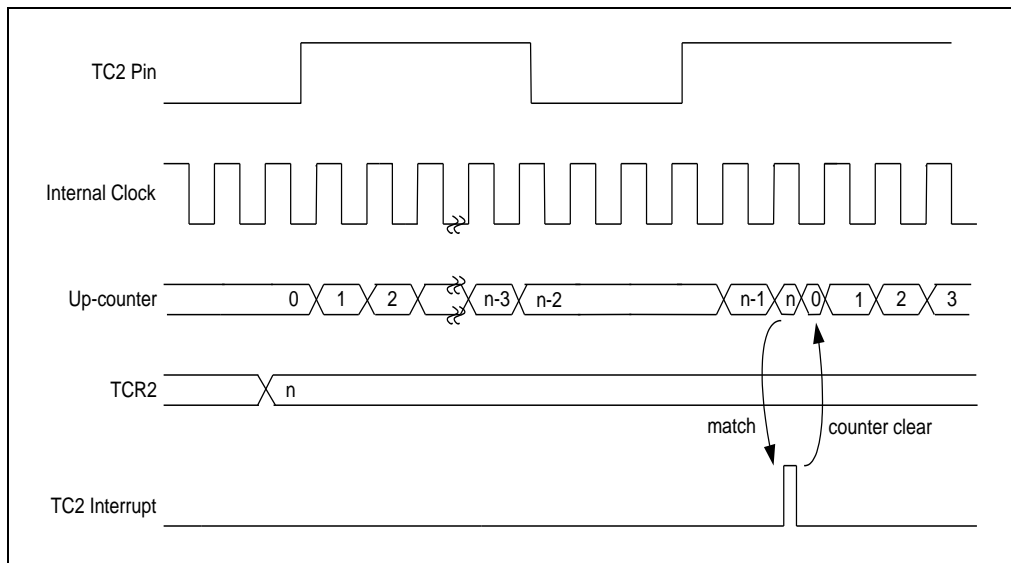

Figure 6-22 Window Mode Timing Chart

6.10 Timer/Counter 3

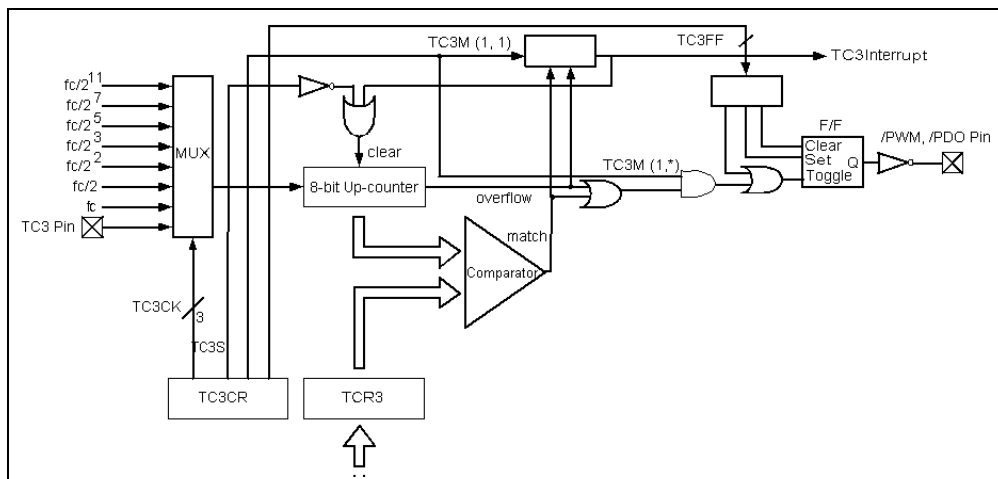

Figure 6-23 Timer / Counter 3 Configuration

In Timer mode, counting up is performed using the internal clock (rising edge trigger). When the contents of the up-counter match the contents of TCR3, interrupt is generated and the counter is cleared. Counting up resumes after the counter is cleared.

In Counter mode, counting up is performed using the external clock input pin (TC3 pin). When the contents of the up-counter match the contents of TCR3, interrupt is generated and the counter is cleared. Counting up resumes after the counter is cleared.

In Programmable Divider Output (PDO) mode, counting up is performed using the internal clock. The contents of TCR3 are compared with the contents of the up-counter. The F/F output is toggled and the counter is cleared each time a match is found. The F/F output is inverted and output to /PDO pin. This mode can generate 50% duty pulse output. **The F/F can be initialized by the program and it is initialized to “0” during reset.** A TC3 interrupt is generated each time the /PDO output is toggled.

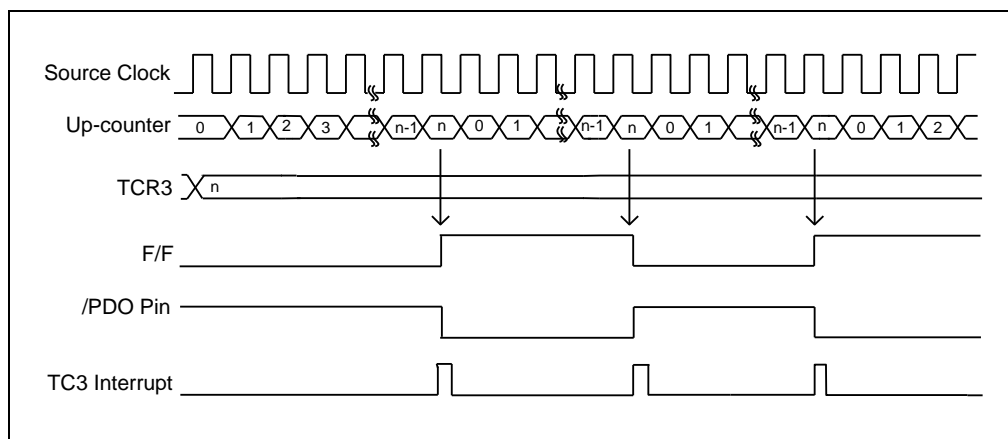

Figure 6-24 PDO Mode Timing Chart

In Pulse Width Modulation (PWM) Output mode, counting up is performed using the internal clock. The contents of TCR3 are compared with the contents of the up-counter. The F/F is toggled when a match is found. While the counter is counting, the F/F is toggled again when the counter overflows, then the counter is cleared. The F/F output is inverted and output to the /PWM pin. A TC3 interrupt is generated each time an overflow occurs. **TCR3 is configured as a 2-stage shift register and during output, will not switch until one output cycle is completed even if TCR3 is overwritten.** Hence, the output can be changed continuously. Also, on the first time, TCR3 is shifted by setting TC3S to "1" after data is loaded to TCR3.

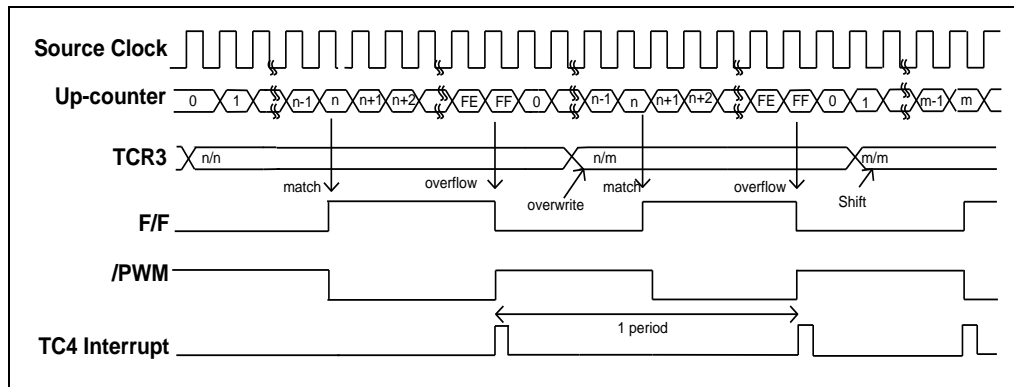

Figure 6-25 PWM Mode Timing Chart

6.11 Comparator

The EM78F562N/F662N has one comparator comprising of two analog inputs and one output. The comparator can be utilized to wake up the EM78F562N/F662N from sleep mode. The comparator circuit diagram is depicted in the figure below.

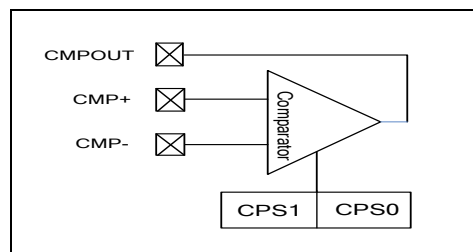

Figure 6-26 Comparator Block Diagram

NOTE

- The reference signal must be between V_{ss} and V_{dd} .
- The reference voltage can be applied to either pin of the comparator.
- Threshold detector applications may be of the same reference.
- The comparator can operate from the same or different reference sources.

6.11.1 Comparator Outputs

- The compared result is stored in the CPOUT of Bank 2 RB.
- The comparator outputs are sent to CMPOUT (P60) by programming Bit 1, Bit 0 <CPS1, CPS0> of the Bank 2 RB register to <1, 0>. See Section 6.1.27, *Bank 2 RB (CMPCON: Comparator Control Register)* for Comparator select bits function description.

The following figure shows the Comparator Output block diagram.

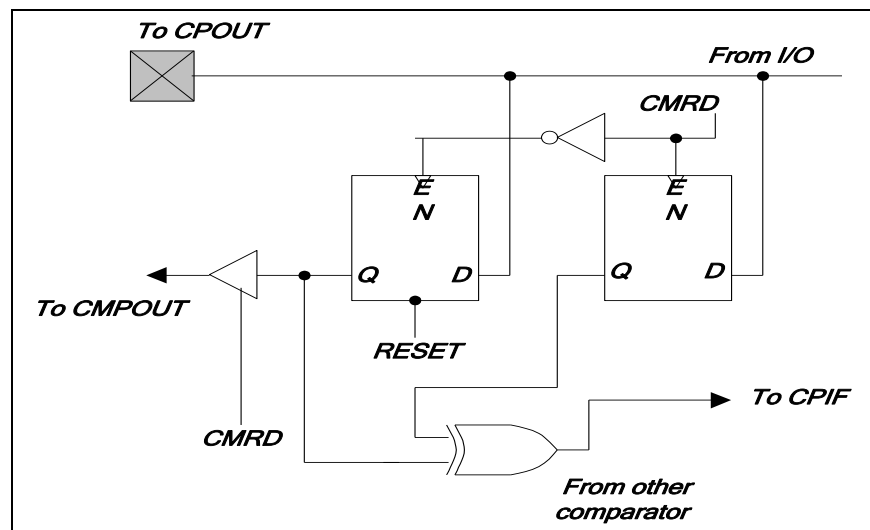

Figure 6-27 Comparator Output Configuration

6.11.2 Comparator Interrupt

- CMPIE (IOCF.7) must be enabled in order for the “ENI” instruction to take effect.
- Interrupt is triggered whenever a change occurs on the comparator output pin.
- The actual change on the pin can be determined by reading the Bit CPOUT, Bank 2 RB<2>.
- CMPIF (Bank 0, RF.7), the comparator interrupt flag, can only be cleared by software.

6.11.3 Wake-up from Sleep Mode

- If enabled, the comparator remains active and the interrupt remains functional, even in Sleep mode.
- If a mismatch occurs, the interrupt will wake up the device from Sleep mode.
- Power consumption should be taken into consideration for the benefit of energy conservation.
- If the function is unemployed during Sleep mode, turn off the comparator before entering into sleep mode.

6.12 Oscillator

6.12.1 Oscillator Modes

The device can be operated in four different oscillator modes, such as Internal RC oscillator mode (IRC), External RC oscillator mode (ERC), High Crystal oscillator mode (HXT), and Low Crystal oscillator mode (LXT). User can select one of such modes by programming OSC2, OCS1 and OSC0 in the Code Option register. Table 6-6 depicts how these four modes are defined.

The up-limited operation frequency of the crystal/resonator on the different VDD is listed in Table 6-7:

Table 6-6 Oscillator Modes defined by OSC2 ~ OSC0

Mode	OSC2	OSC1	OSC0
XT (Crystal oscillator mode)	0	0	0
HXT (High Crystal oscillator mode)	0	0	1
LXT1 (Low Crystal 1 oscillator mode)	0	1	0
LXT2 (Low Crystal 2 oscillator mode)	0	1	1
IRC mode, OSC0 (P54) act as I/O pin	1	0	0
IRC mode, OSC0 (P54) act as RCOUT pin	1	0	1
ERC mode, OSC0 (P54) act as I/O pin	1	1	0
ERC mode, OSC0 (P54) act as RCOUT pin	1	1	1

- Note:**
1. The Frequency range of the HXT mode is 16 MHz ~ 6 MHz.
 2. The Frequency range of the XT mode is 6 MHz ~ 1 MHz.
 3. The Frequency range of the LXT1 mode is 1 MHz ~ 100kHz.
 4. The Frequency range of the LXT2 mode is 32kHz.

In LXT, XT, HXT and ERC mode, OSC1 and OSC0 are implemented but they cannot be used as normal I/O pins.

In IRC mode, P55 is used as normal I/O pin.

Table 6-7 Summary of Maximum Operating Speeds

Conditions	VDD	Max. Fxt. (MHz)
Two cycles with two clocks	2.5	4.0
	3.0	8.0
	5.0	20.0

6.12.2 Crystal Oscillator/Ceramic Resonators (Crystal)

The EM78F562N/F662N can be driven by an external clock signal through the OSCI pin as shown in Figure 6-28 below.

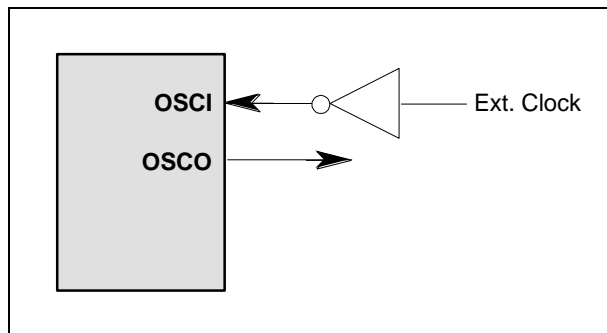

Figure 6-28 Circuit for External Clock Input

In most applications, pin OSCI and pin OSCO can be connected with a crystal or ceramic resonator to generate oscillation. Figure 6-29 depicts such a circuit. The same thing applies whether it is in the HXT mode or in the LXT mode. Table 6-8 provides the recommended values for C1 and C2. Since each resonator has its own attribute, user should refer to its specification for appropriate values of C1 and C2. RS, a serial resistor, may be necessary for AT strip cut crystal or low frequency mode.

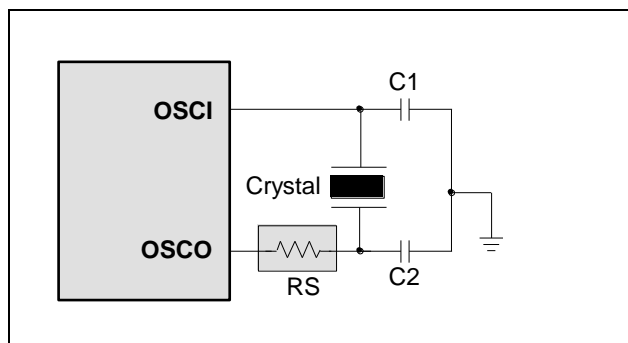

Figure 6-29 Circuit for Crystal/Resonator

Table 6-8 Capacitor Selection Guide for Crystal Oscillator or Ceramic Resonator

Oscillator Type	Frequency Mode	Frequency	C1 (pF)	C2 (pF)
Ceramic Resonators	LXT1 (100K~1 MHz)	100kHz	45pF	45pF
		200kHz	20pF	20pF
		455kHz	20pF	20pF
		1.0 MHz	20pF	20pF
	HXT2 (1 M~6 MHz)	1.0 MHz	25pF	25pF
		2.0 MHz	20pF	20pF
4.0 MHz		20pF	20pF	
Crystal Oscillator	LXT2 (32.768kHz)	32.768kHz	40pF	40pF
	LXT1 (100K~1 MHz)	100kHz	45pF	45pF
		200kHz	20pF	20pF
		455kHz	20pF	20pF
		1.0 MHz	20pF	20pF
	XT (1~6 MHz)	455kHz	30pF	30pF
		1.0 MHz	20pF	20pF
		2.0 MHz	20pF	20pF
		4.0 MHz	20pF	20pF
		6.0 MHz	20pF	20pF
	HXT (6~20 MHz)	6.0 MHz	25pF	25pF
		8.0 MHz	20pF	20pF
		10.0 MHz	20pF	20pF
		16.0 MHz	20pF	20pF
		20.0 MHz	15pF	15pF

6.12.3 External RC Oscillator Mode

For some applications that do not require a very precise timing calculation, the RC oscillator (Figure 6-30) offers a cost-effective oscillator configuration. Nevertheless, it should be noted that the frequency of the RC oscillator is influenced by the supply voltage, the values of the resistor (R_{ext}), the capacitor (C_{ext}), and even by the operation temperature. Moreover, the frequency also changes slightly from one chip to another due to manufacturing process variation.

In order to maintain a stable system frequency, the values of the C_{ext} should not be lesser than 20pF, and that the value of R_{ext} should not be greater than 1 M Ω . If they cannot be kept in this range, the frequency is easily affected by noise, humidity, and leakage.

The smaller the R_{ext} in the RC oscillator, the faster its frequency will be. On the contrary, for very low R_{ext} values, for instance, $1\text{ K}\Omega$, the oscillator becomes unstable since the NMOS cannot discharge correctly the current of the capacitance.

Based on the above reasons, it must be kept in mind that the supply voltage, the operation temperature, the components of the RC oscillator, the package types, and the PCB layout, will affect the system frequency.

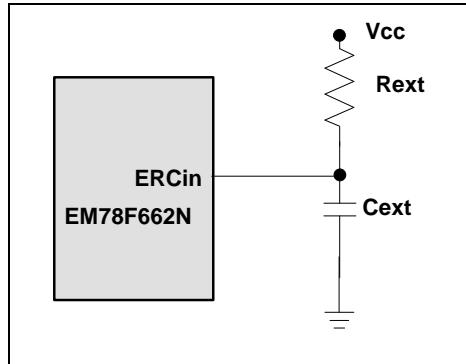

Figure 6-30 Circuit for External RC Oscillator Mode

Table 6-9 RC Oscillator Frequencies

Cext	Rext	Average Fosc 5V, 25°C	Average Fosc 3V, 25°C
20 pF	3.3k	3.5 MHz	3.2 MHz
	5.1k	2.5 MHz	2.3 MHz
	10k	1.30 MHz	1.25 MHz
	100k	140kHz	140kHz
100 pF	3.3k	1.27 MHz	1.21 MHz
	5.1k	850kHz	820kHz
	10k	450kHz	450kHz
	100k	48kHz	50kHz
300 pF	3.3k	560kHz	540kHz
	5.1k	370kHz	360kHz
	10k	196kHz	192kHz
	100k	20kHz	20kHz

Note: 1: These are measured based on DIP packages.

2: These values are for design reference only. Actual values may vary depending on the actual process.

6.12.4 Internal RC Oscillator Mode

Table 6-10 Internal RC Drift Rate (Ta=25°C, VDD=5 V± 5%, VSS=0V)

Internal RC	Drift Rate			
	Temperature (-40°C~85°C)	Voltage (2.2V~5.5V)	Process	Total
1 MHz	± 3%	± 4%	± 2.5%	± 9.5%
4 MHz	± 3%	± 4%	± 2.5%	± 9.5%
8 MHz	± 3%	± 5%	± 2.5%	± 10.5%
16 MHz	± 3%	± 5%	± 2.5%	± 10.5%

6.13 Code Option Register

The EM78F562N/F662N has a Code option word that is not part of the normal program memory. The option bits cannot be accessed during normal program execution.

Code Option Register and Customer ID Register arrangement distribution:

Word 0	Word 1	Word 2
Bit 12~Bit 0	Bit 12~Bit 0	Bit 12~Bit 0

6.13.1 Code Option Register (Word 0)

Word 0													
Bit	Bit 12	Bit 11	Bit 10	Bit 9	Bit 8	Bit 7	Bit 6	Bit 5	Bit 4	Bit 3	Bit 2	Bit 1	Bit 0
Mnemonic	-	NRHL	NRE	RESETENB	CLKS1	CLKS0	ENWDTB	OSC2	OSC1	OSC0	PR2	PR1	PR0
1	-	8/fc	Disable	Enable	High	High	Enable	High	High	High	High	High	High
0	-	32/fc	Enable	Disable	Low	Low	Disable	Low	Low	Low	Low	Low	Low

Bit 12: Not used, always set to “0”.

Bit 11 (NRHL): Noise rejection high/low pulse defined bit. The INT pin is a falling edge trigger.

1 : Pulses equal to 8/fc [s] are regarded as signal

0 : Pulses equal to 32/fc [s] are regarded as signal (default)

NOTE

The noise rejection function is turned off in the LXT2 and sleep mode.

Bit 10 (NRE): Noise rejection enable (depends on EM78F562N/F662N). The INT pin is a falling edge trigger.

1 : Disable noise rejection

0 : Enable noise rejection (default) but in Low Crystal oscillator (LXT) mode, the noise rejection circuit is always disabled

Bit 9 (RESETENB): Reset Pin Enable Bit

0 : Disable, P83//RESET → P83 (default)

1 : Enable, P83//RESET → RESET pin

Bit 8 ~ Bit 7 (CLKS1 ~ CLKS0): Instruction period option bit

Instruction Period	CLKS1	CLKS0
4 clocks	0	0
2 clocks	0	1
8 clocks	1	0
16 clocks	1	1

Refer to the Instruction Set section.

Bit 6 (ENWDTB): Watchdog timer enable bit

0 : Disable

1 : Enable

Bit 5 ~ Bit 3 (OSC2 ~ OSC0): Oscillator Mode Select bits

Oscillator Modes defined by OSC2 ~ OSC0

Mode	OSC2	OSC1	OSC0
XT (Crystal oscillator mode)	0	0	0
HXT (High Crystal oscillator mode)	0	0	1
LXT1 (Low Crystal 1 oscillator mode)	0	1	0
LXT2 (Low Crystal 2 oscillator mode)	0	1	1
IRC mode, OSC0 (P54) act as I/O pin	1	0	0
IRC mode, OSC0 (P54) act as RCOUT pin	1	0	1
ERC mode, OSC0 (P54) act as I/O pin	1	1	0
ERC mode, OSC0 (P54) act as RCOUT pin	1	1	1

Note: 1. Frequency range of HXT mode is 16 MHz ~ 6 MHz.

2. Frequency range of XT mode is 6 MHz ~ 1 MHz.

3. Frequency range of LXT1 mode is 1 MHz ~ 100kHz.

4. Frequency range of LXT2 mode is 32kHz.

Bit 2 ~ Bit 0 (PR2 ~ PR0): Protect Bits. Protect type is as follows:

PR2	PR1	PR0	Protect
1	1	1	Enable
0	0	0	Disable

6.13.2 Code Option Register (Word 1)

Word 1													
Bit	Bit 12	Bit 11	Bit 10	Bit 9	Bit 8	Bit 7	Bit 6	Bit 5	Bit 4	Bit 3	Bit 2	Bit 1	Bit 0
Mnemonic	COBS	TCEN	-	-	C4	C3	C2	C1	C0	RCM1	RCM0	LVR1	LVR0
1	High	TCC	-	-	High	High	High	High	High	High	High	High	High
0	Low	P77	-	-	Low	Low	Low	Low	Low	Low	Low	Low	Low

Bits 12 (COBS): Code Option Bit Select

0 : IRC frequency select for code option (default)

1 : IRC frequency select for internal register by Bank 1 R8 (7, 6)

Bit 11 (TCEN): TCC enable bit

0 : P77/TCC is set as P77

1 : P77/TCC is set as TCC

Bit 10 ~ Bit 9: fixed to "1"

Bit 8 ~ Bit 4 (C4 ~ C0): Internal RC mode calibration bits. C4 ~ C0 must be set to "0" only (auto-calibration).

Bit 3 ~ Bit 2 (RCM1 ~ RCM0): RC mode selection bits

RCM 1	RCM 0	*Frequency (MHz)
0	0	4
0	1	16
1	0	8
1	1	1

Bit 1 ~ Bit 0 (LVR1 ~ LVR0): Low Voltage Reset Enable bits

LVR1	LVR0	Reset Level	Release Level
0	0	NA	NA
0	1	2.7V	2.9V
1	0	3.5V	3.7V
1	1	4.0V	4.2V

LVR1, LVR0="0, 0" : LVR disable, power- on reset point of EM78F562N/F662N is 2.0V.

LVR1, LVR0="0, 1" : If Vdd < 2.7V, the EM78F562N/F662N will be reset.

LVR1, LVR0="1, 0" : If Vdd < 3.5V, the EM78F562N/F662N will be reset.

LVR1, LVR0="1, 1" : If Vdd < 4.0V, the EM78F562N/F662N will be reset.

6.13.3 Customer ID Register (Word 2)

Word 2													
Bit	Bit 12	Bit 11	Bit 10	Bit 9	Bit 8	Bit 7	Bit 6	Bit 5	Bit 4	Bit 3	Bit 2	Bit 1	Bit 0
Mnemonic	SC3	SC2	SC1	SC0	-	-	-	-	SFS	×	×	×	×X
1	High	High	High	High	-	-	-	-	128kHz	High	High	High	High
0	Low	Low	Low	Low	-	-	-	-	16kHz	Low	Low	Low	Low

Bits 12 ~ 9 (SC3 ~ SC0): Calibrator of sub frequency (WDT frequency auto calibration)

Bit 8: fixed to "0"

Bit 7: fixed to "1"

Bits 6 ~ 5: fixed to “0”

Bit 4 (SFS): Sub Frequency Select

0: 16kHz (WDT frequency)

1: 128kHz

Bits 3 ~ 0: Customer's ID code

6.14 Power-on Considerations

Any microcontroller is not guaranteed to start to operate properly before the power supply has stabilized. The EM78F562N/F662N has an on-chip Power-on Voltage Detector (POVD) with a detecting level of 2.0V. It will work well if Vdd can rise quickly enough (50ms or less). In many critical applications, however, extra devices are still required to assist in solving power-up problems.

6.15 External Power-on Reset Circuit

The circuit shown in Figure 6-31 uses an external RC to produce a reset pulse. The pulse width (time constant) should be kept long enough for Vdd to reach minimum operating voltage. This circuit is used when the power supply has a slow rise time. Because the current leakage from the /RESET pin is $\pm 5 \mu\text{A}$, it is recommended that R should not be greater than 40K. In this way, the /RESET pin voltage is held below 0.2V. The diode (D) functions as a short circuit at the moment of power down.

The capacitor C will discharge rapidly and fully. The current-limited resistor (Rin), will prevent high current or ESD (electrostatic discharge) from flowing to Pin /RESET.

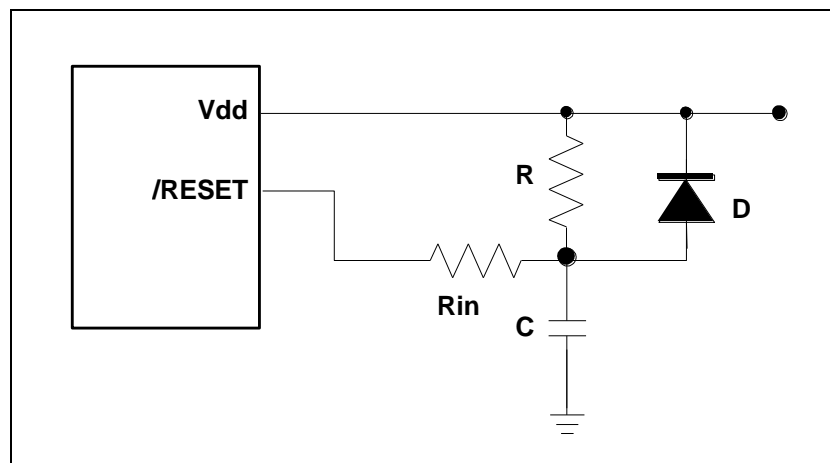

Figure 6-31 External Power-up Reset Circuit

6.16 Residue-Voltage Protection

When the battery is replaced, device power (Vdd) is taken off but residue-voltage remains. The residue-voltage may trip below Vdd minimum, but not to zero. This condition may cause a poor power-on reset. Figure 6-32 and Figure 6-33 shows how to build a residue-voltage protection circuit.

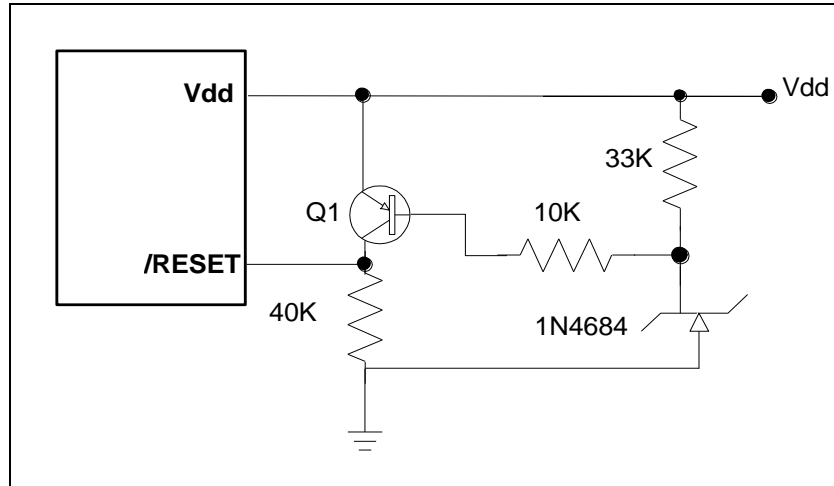

Figure 6-32 Residue Voltage Protection Circuit 1

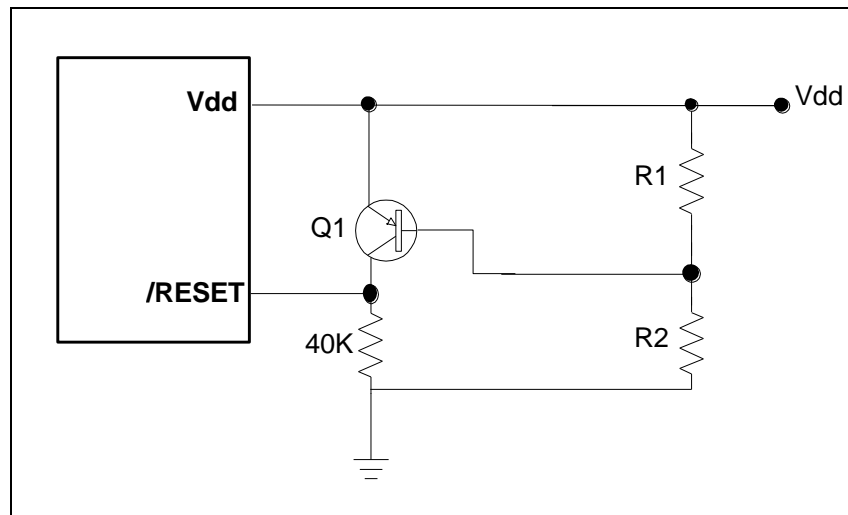

Figure 6-33 Residue Voltage Protection Circuit 2

6.17 Instruction Set

Each instruction in the instruction set is a 13-bit word divided into an OP code and one or more operands. Normally, all instructions are executed within one single instruction cycle (one instruction consists of two oscillator periods), unless the program counter is changed by instruction "MOV R2,A", "ADD R2,A", or by instructions of arithmetic or logic operation on R2 (e.g. "SUB R2,A", "BS(C) R2,6", "CLR R2", etc.). In this case, the execution takes two instruction cycles.

If for some reasons, the specification of the instruction cycle is not suitable for certain applications, try to modify the instructions as follows:

- (A) Change one instruction cycle to consist of four oscillator periods.
- (B) "JMP", "CALL", "RET", "RETL", "RETI" commands are executed with one instruction cycle, the conditional skip ("JBS", "JBC", "JZ", "JZA", "DJZ", "DJZA") commands which were tested to be true, are executed within two instruction cycles. The instructions that are written to the program counter also take two instruction cycles.

Case (A) is selected by the Code Option bit, called CLK. One instruction cycle consists of two oscillator clocks if CLK is low and four oscillator clocks if CLK is high.

Note that once the four oscillator periods within one instruction cycle is selected as in Case (A), the internal clock source to TCC should be $CLK = F_{osc}/4$, instead of $F_{osc} / 2$ as indicated in Figure 6-11.

In addition, the instruction set has the following features:

- (1) Every bit of any register can be set, cleared, or tested directly.
- (2) The I/O register can be regarded as general register. That is, the same instruction can operate on the I/O register.

Instruction Set Convention:

R = Register designator that specifies which one of the registers (including operation and general purpose registers) is to be utilized by the instruction.

b = Bit field designator that selects the value for the bit located in the register R and which affects the operation.

k = 8 or 10-bit constant or literal value

Mnemonic	Operation	Status Affected
NOP	No Operation	None
DAA	Decimal Adjust A	C
CONTW	A → CONT	None
SLEP	0 → WDT, Stop oscillator	T, P
WDTC	0 → WDT	T, P
IOW R	A → IOCR	None ¹
ENI	Enable Interrupt	None
DISI	Disable Interrupt	None
RET	[Top of Stack] → PC	None
RETI	[Top of Stack] → PC, Enable Interrupt	None
CONTR	CONT → A	None
IOR R	IOCR → A	None ¹
MOV R,A	A → R	None
CLRA	0 → A	Z
CLR R	0 → R	Z
SUB A,R	R-A → A	Z, C, DC
SUB R,A	R-A → R	Z, C, DC
DECA R	R-1 → A	Z
DEC R	R-1 → R	Z
OR A,R	A ∨ R → A	Z
OR R,A	A ∨ R → R	Z
AND A,R	A & R → A	Z
AND R,A	A & R → R	Z
XOR A,R	A ⊕ R → A	Z
XOR R,A	A ⊕ R → R	Z
ADD A,R	A + R → A	Z, C, DC
ADD R,A	A + R → R	Z, C, DC
MOV A,R	R → A	Z
MOV R,R	R → R	Z
COMA R	/R → A	Z
COM R	/R → R	Z
INCA R	R+1 → A	Z
INC R	R+1 → R	Z

Note:¹ This instruction is applicable to IOC5~IOC7, IOCA ~ IOCF only.

Mnemonic	Operation	Status Affected
DJZA R	R-1 → A, skip if zero	None
DJZ R	R-1 → R, skip if zero	None
RRCA R	R(n) → A(n-1), R(0) → C, C → A(7)	C
RRC R	R(n) → R(n-1), R(0) → C, C → R(7)	C
RLCA R	R(n) → A(n+1), R(7) → C, C → A(0)	C
RLC R	R(n) → R(n+1), R(7) → C, C → R(0)	C
SWAPA R	R(0-3) → A(4-7), R(4-7) → A(0-3)	None
SWAP R	R(0-3) ↔ R(4-7)	None
JZA R	R+1 → A, skip if zero	None
JZ R	R+1 → R, skip if zero	None
BC R,b	0 → R(b)	None ²
BS R,b	1 → R(b)	None ³
JBC R,b	if R(b)=0, skip	None
JBS R,b	if R(b)=1, skip	None
CALL k	PC+1 → [SP], (Page, k) → PC	None
JMP k	(Page, k) → PC	None
MOV A,k	k → A	None
OR A,k	A ∨ k → A	Z
AND A,k	A & k → A	Z
XOR A,k	A ⊕ k → A	Z
RETL k	k → A, [Top of Stack] → PC	None
SUB A,k	k-A → A	Z, C, DC
ADD A,k	k+A → A	Z, C, DC
BANK k	K → R4(7:6)	None
LCALL k	Next instruction : k kkkk kkkk kkkk PC+1 → [SP], k → PC ⁴	None
LJMP k	Next instruction : k kkkk kkkk kkkk k → PC4	None
TBRD R	If Bank 3 R6.7=0, machine code (7:0) → R Else machine code (12:8) → R(4:0), R(7:5)=(0,0,0)	None

Note:² This instruction is not recommended for interrupt status register operation.

³ This instruction cannot operate under interrupt status register.

⁴ This instruction cannot modify the R3 (5) bit.

7 Timing Diagrams

AC Test Input/Output Waveform

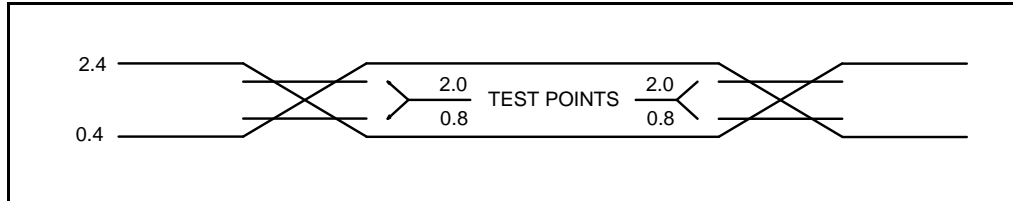

Note: AC Testing: Input are driven at 2.4V for logic "1," and 0.4V for logic "0"
Timing measurements are made at 2.0V for logic "1," and 0.8V for logic "0"

Figure 7-1a AC Test Input/Output Waveform Timing Diagram

Reset Timing (CLK="0")

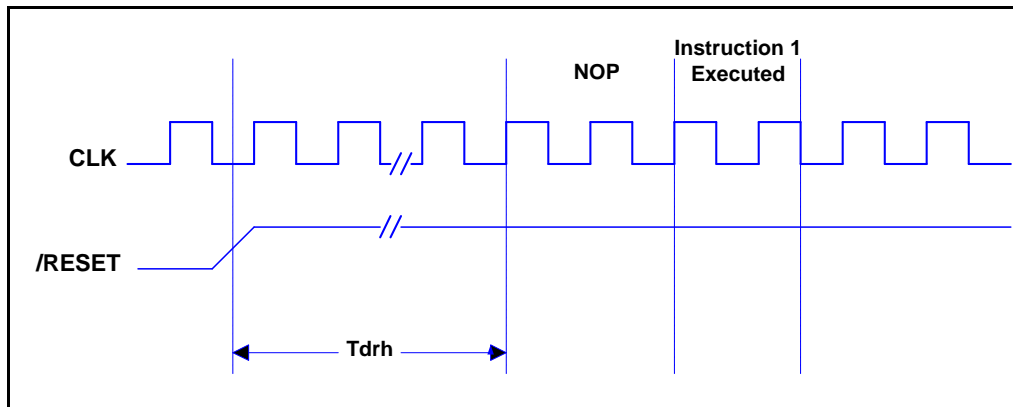

Figure 7-1b Reset Timing Diagram

TCC Input Timing (CLKS="0")

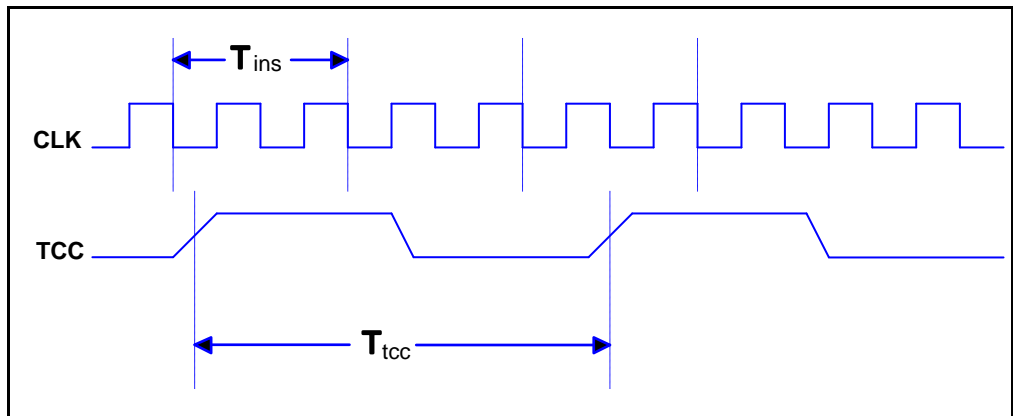

Figure 7-1c TCC Input Timing Diagram

8 Absolute Maximum Ratings

■ EM78F562N/F662N

Items	Rating		
Temperature under bias	-40°C	to	85°C
Storage temperature	-65°C	to	150°C
Working voltage	2.2	to	5.5V
Working frequency	DC	to	20 MHz
Input voltage	V _{ss} -0.3V	to	V _{dd} +0.5V
Output voltage	V _{ss} -0.3V	to	V _{dd} +0.5V

Note: These parameters are theoretical values and have not been tested.

9 DC Electrical Characteristics

(T_a=25°C, V_{DD}=5.0V±5%, V_{SS}=0V)

Symbol	Parameter	Condition	Min.	Typ.	Max.	Unit
Fxt	Crystal: VDD to 3V	Two cycles with two clocks	DC	-	8	MHz
	Crystal: VDD to 5V		DC	-	20	MHz
	ERC: VDD to 5V	R: 5.1KΩ, C: 100 pF	F±30%	830	F±30%	kHz
	IRC: VDD to 5V	4MHz, 16MHz, 8MHz, 1MHz	F±30%	F	F±30%	Hz
IIL	Input Leakage Current for input pins	V _{IN} = V _{DD} , V _{SS}	-	-	±1	μA
VIHRC	Input High Threshold Voltage (Schmitt trigger)	OSCI in RC mode	3.9	4	4.1	V
IERC1	Sink current	V _I from low to high, V _I =5V	21	22	23	mA
VILRC	Input Low Threshold Voltage (Schmitt trigger)	OSCI in RC mode	1.7	1.8	1.9	V
IERC2	Sink current	V _I from high to low, V _I =2V	16	17	18	mA
IIL	Input Leakage Current for input pins	V _{IN} = V _{DD} , V _{SS}	-1	0	1	μA
VIH1	Input High Voltage (Schmitt trigger)	Ports 5, 6, 7, 8	-	0.7V _{DD}	-	V
VIL1	Input Low Voltage (Schmitt trigger)	Ports 5, 6, 7, 8	-	0.3V _{DD}	-	V
VIHT1	Input High Threshold Voltage (Schmitt trigger)	/RESET	-	0.7V _{DD}	-	V
VILT1	Input Low Threshold Voltage (Schmitt trigger)	/RESET	-	0.3V _{DD}	-	V
VIHT2	Input High Threshold Voltage (Schmitt trigger)	TCC, INT	-	0.7V _{DD}	-	V
VILT2	Input Low Threshold Voltage (Schmitt trigger)	TCC, INT	-	0.3V _{DD}	-	V
VIHX1	Clock Input High Voltage	OSCI in crystal mode	2.9	3.0	3.1	V
VILX1	Clock Input Low Voltage	OSCI in crystal mode	1.7	1.8	1.9	V
IOH1	Output High Voltage (Ports 5, 6, 7, 8)	V _{OH} = 0.9V _{DD}	-3	-	-	mA
IOL1	Output Low Voltage (Ports 5, 7, 8)	V _{OL} = 0.1V _{DD}	14	-	-	mA



Symbol	Parameter	Condition	Min.	Typ.	Max.	Unit
IOL2	Output Low Voltage (Ports 6)	VOL = 0.1VDD	-	18	-	mA
LVR1	Low Voltage Reset level	Ta= 25°C	2.4	2.7	3.02	V
		Ta= -40~85°C	2.07	2.7	3.37	V
LVR2	Low Voltage Reset level	Ta= 25°C	3.09	3.5	3.98	V
		Ta= -40~85°C	2.58	3.5	4.46	V
LVR3	Low Voltage Reset level	Ta= 25°C	3.51	4.0	4.51	V
		Ta= -40~85°C	2.98	4.0	5.06	V
IPH	Pull-high current	Pull-high active, input pin at VSS	-	-	-80	μA
IPL	Pull-low current	Pull-low active, input pin at Vdd	-	-	30	μA
ISB1	Power down current	All input and I/O pins at VDD, output pin floating, WDT disabled	-	1.5	-	μA
ISB2	Power down current	All input and I/O pins at VDD, output pin floating, WDT enabled	-	11	-	μA
ICC1	Operating supply current at two clocks	/RESET= 'High', Fosc=32kHz (Crystal type), output pin floating, WDT disabled	-	43	-	μA
ICC2	Operating supply current at two clocks	/RESET= 'High', Fosc=32kHz (Crystal type), output pin floating, WDT enabled	-	43	-	μA
ICC3	Operating supply current at two clocks	/RESET= 'High', Fosc=4MHz (Crystal type), output pin floating, WDT enabled	-	-	1	mA
ICC4	Operating supply current at two clocks	/RESET= 'High', Fosc=10MHz (Crystal type), output pin floating, WDT enabled	-	-	2.8	mA
ICC5	Operating supply current at two clocks	/RESET= 'High', Fosc=1MHz (IRC type), Voltage = 3V, output pin floating, WDT enabled	-	180	-	μA

Note: These parameters are theoretical values and have not been tested nor verified.

Data in the Minimum, Typical, Maximum ("Min.", "Typ.", "Max.") columns are based on characterization results at 25°C. These data are for design reference only and have not been tested.

9.1 Data EEPROM Electrical Characteristics

Symbol	Parameter	Condition	Min.	Typ.	Max.	Unit
Tprog	Erase/Write cycle time	Vdd = 2.4~ 5.5V Temperature = -40 ~ 85°C	-	4.5	-	ms
Treten	Data Retention		-	10	-	Years
Tendu	Endurance time		-	1000K	-	Cycles
Iprg	Programming	Vdd ≤ 3.3V	-	0.6	-	mA
		Vdd ≤ 5.5V	-	1.0	-	mA
Iread	Read	Vdd ≤ 3.3V	-	1.0	-	mA
		Vdd ≤ 5.5V	-	2.5	-	mA

9.2 Program Flash Memory Electrical Characteristics

Symbol	Parameter	Condition	Min.	Typ.	Max.	Unit
Tprog	Erase/Write cycle time	Vdd = 5.0V Temp. = -40~85°C	-	4	-	ms
Treten	Data Retention		-	10	-	Years
Tendu	Endurance time		-	100K	-	Cycles

9.3 A/D Converter Characteristics

(Vdd=2.5V to 5.5V, Vss=0V, Ta=25°C)

Symbol	Parameter	Condition	Min.	Typ.	Max.	Unit
VAREF	Analog reference voltage	VAREF-VASS= 2.5V to 5.5V	2.5	Vss	Vdd	V
VASS						
VAI	Analog input voltage	-	VASS	-	VAREF	V
IAI1	Ivdd	VAREF = Vdd	1150	1300	1450	μA
	Ivref	-	-10	0	10	μA
IAI2	Ivdd	VAREF = VREF	700	800	900	μA
	Ivref	-	450	500	550	μA
RN	Resolution	VAREF=Vdd	8	9	-	Bits
LN	Linearity error	VAREF=Vdd	0	±2	±4	LSB
DNL	Differential nonlinear error	VAREF=Vdd	0	±0.5	±0.9	LSB
FSE	Full scale error	VAREF=Vdd	±0	±1	±2	LSB
OE	Offset error	VAREF=Vdd	±0	±1	±2	LSB
ZAI	Recommended impedance of analog voltage source	VAREF=Vdd	0	8	10	KΩ
TAD1	A/D clock period	VAREF=Vdd=2.5~5.5V Ta= -40~85°C	4	-	-	μs
TAD2	A/D clock period	VAREF=Vdd=3~5.5V Ta= -40~85°C	1	-	-	μs
TCN	A/D conversion time	VAREF=Vdd	14	-	14	TAD
PSR	Power supply rejection	Vdd=Vdd-10% to Vdd+10%	±0	-	±2	LSB

- Note:**
1. These parameters are characterized but not tested.
 2. These parameters are for design reference only and are not tested.
 3. When A/D is off, there's no current consumption other than minor leakage current.
 4. The A/D conversion result does not decrease with an increase in the input voltage, and it has no missing code.
 5. Specifications are subject to change without prior notice.

9.4 Comparator Characteristics

Comparator Electrical Characteristics

Symbol	Parameter	Condition	Min.	Typ.	Max.	Unit
VOS	Input offset voltage	RL = 5.1K (Note ¹)	–	–	5	mV
Vcm	Input common-mode voltages range	(Note ²)	GND	–	VDD	V
ICO	Supply current of Comparator	–	–	200	–	uA
TRS	Response time	Vin(-)=2.5V, Vdd=5V, CL=15p (comparator output load), overdrive=30mV (Note ³)	–	0.7	–	us
TLRS	Large signal response time	Vin(-)=2.5V, Vdd=5V, CL=15p (comparator output load),	–	300	–	ns
VS	Operating range	–	2.5	–	5.5	V

Note: ¹ . The output voltage is in the unit gain circuitry and over the full input common-mode range.

² . The input common-mode voltage or either input signal voltage should not be allowed to go negative by more than 0.3V. The upper end of the common-mode voltage range is VDD.

³ . The response time specified is a 100 mV input step with 30 mV overdrive.

10 AC Electrical Characteristics

EM78F562N/F662N, $0 \leq T_a \leq 70^\circ\text{C}$, VDD=5V, VSS=0V

$-40 \leq T_a \leq 85^\circ\text{C}$, VDD=5V, VSS=0V

Symbol	Parameter	Conditions	Min.	Typ.	Max.	Unit
Dclk	Input CLK duty cycle	–	45	50	55	%
Tins	Instruction cycle time (CLKS="0")	Crystal type	100	–	DC	ns
		RC type	500	–	DC	ns
Ttcc	TCC input period	–	(Tins+20)/N*	–	–	ns
Tdrh	Device reset hold time	–	11.8	16.8	21.8	ms
Trst	/RESET pulse width	Ta = 25°C	2000	–	–	ns
Twdt	Watchdog timer period	Ta = 25°C	11.8	16.8	21.8	ms
Tset	Input pin setup time	–	–	0	–	ns
Thold	Input pin hold time	–	–	20	–	ns
Tdelay	Output pin delay time	Cload=20pF	–	50	–	ns

Note: These parameters are theoretical values and have not been tested. Such parameters are for design reference only.

Data in the Minimum, Typical, Maximum ("Min.", "Typ.", "Max.") columns are based on characterization results at 25°C.

* N = selected prescaler ratio

APPENDIX

A Ordering and Manufacturing Information

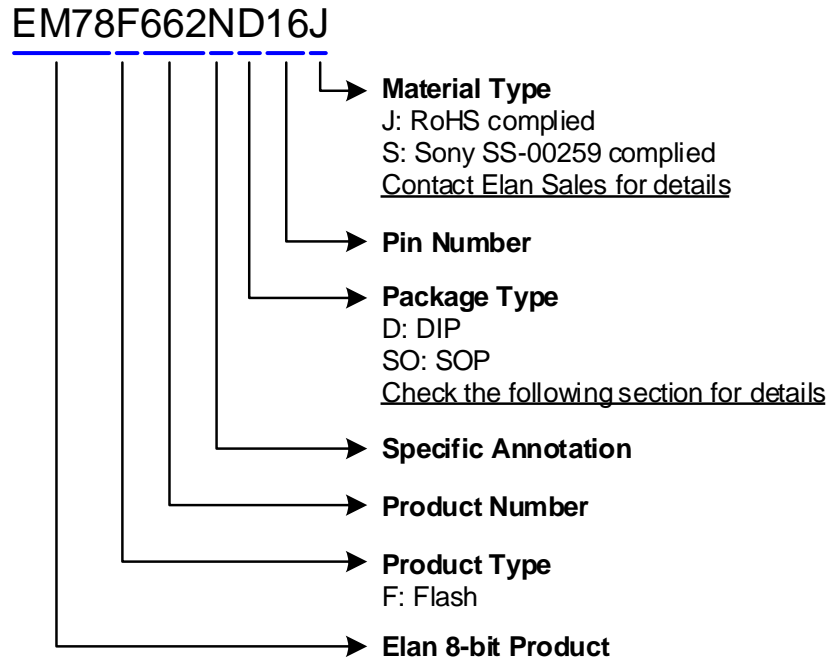

For example:

EM78F662NSO16S

is EM78F662N with Flash program memory,
in 16-pin SOP 300mil package with Sony SS-00259 complied

IC Mark

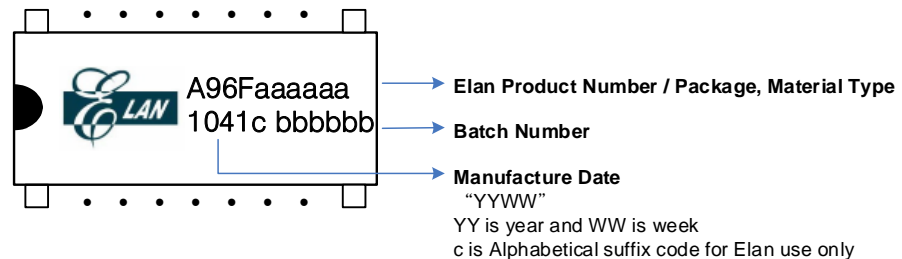

Ordering Code

EM78F662ND14J

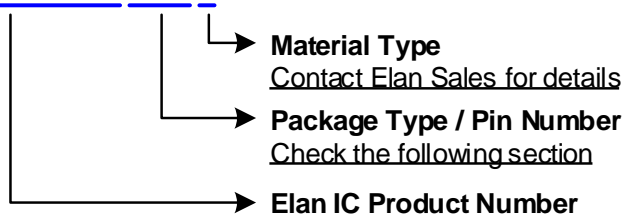

B Package Type

Flash MCU	Package Type	Pin Count	Package Size
EM78F562N/F662ND20	PDIP	20	300 mil
EM78F562N/F662NSO20	SOP	20	300 mil
EM78F562N/F662ND18	PDIP	18	300 mil
EM78F562N/F662NSO18	SOP	18	300 mil
EM78F562N/F662ND16	PDIP	16	300 mil
EM78F562N/F662NSO16	SOP	16	300 mil
EM78F662NQN16A	QFN	16	4x4mm
EM78F662NSS16	SSOP	16	150mil

These are Green products which do not contain hazardous substances and comply with the third edition of Sony SS-00259 standard.

The Pb content is less than 100ppm and complies with Sony specifications.

Part No.	EM78F562N/F662NS/J
Electroplate type	Pure Tin
Ingredient (%)	Sn:100%
Melting point (°C)	232°C
Electrical resistivity ($\mu\Omega$ cm)	11.4
Hardness (hv)	8~10
Elongation (%)	>50%

C Package Information

C.1 EM78F562N/F662ND16 300mil

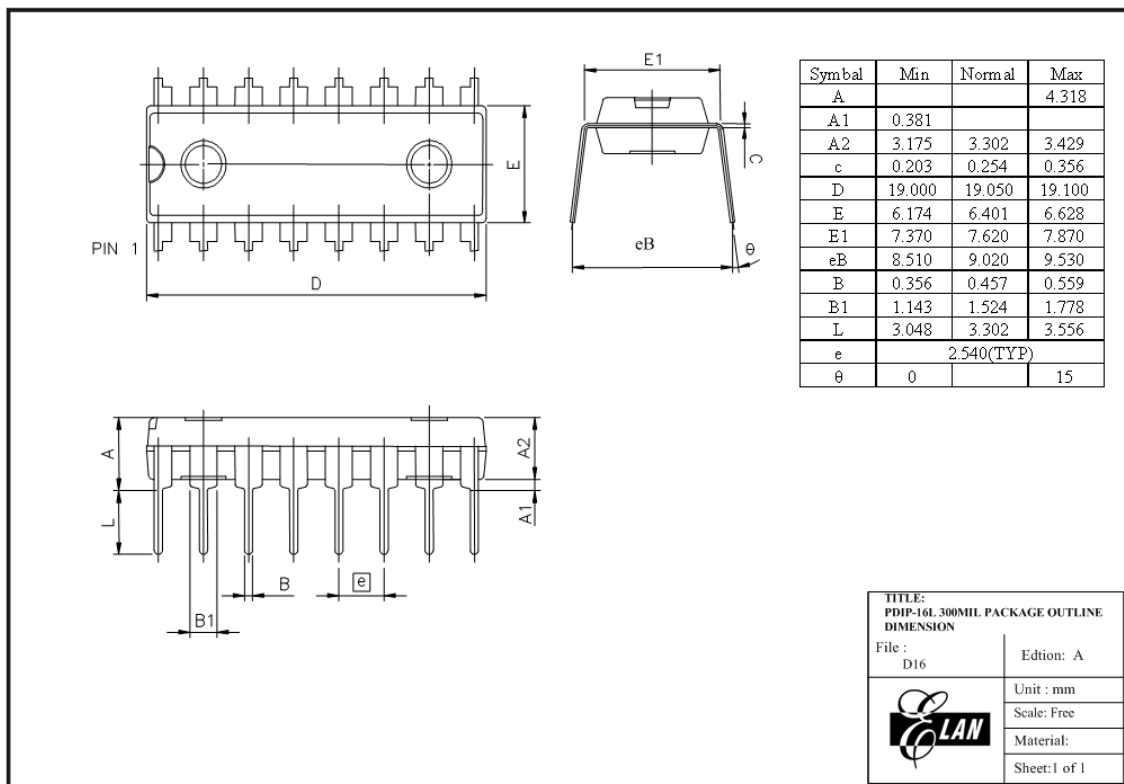

Figure C-1 EM78F562N/F662N 16-pin PDIP Package Type

C.2 EM78F562N/F662NSO16 300mil

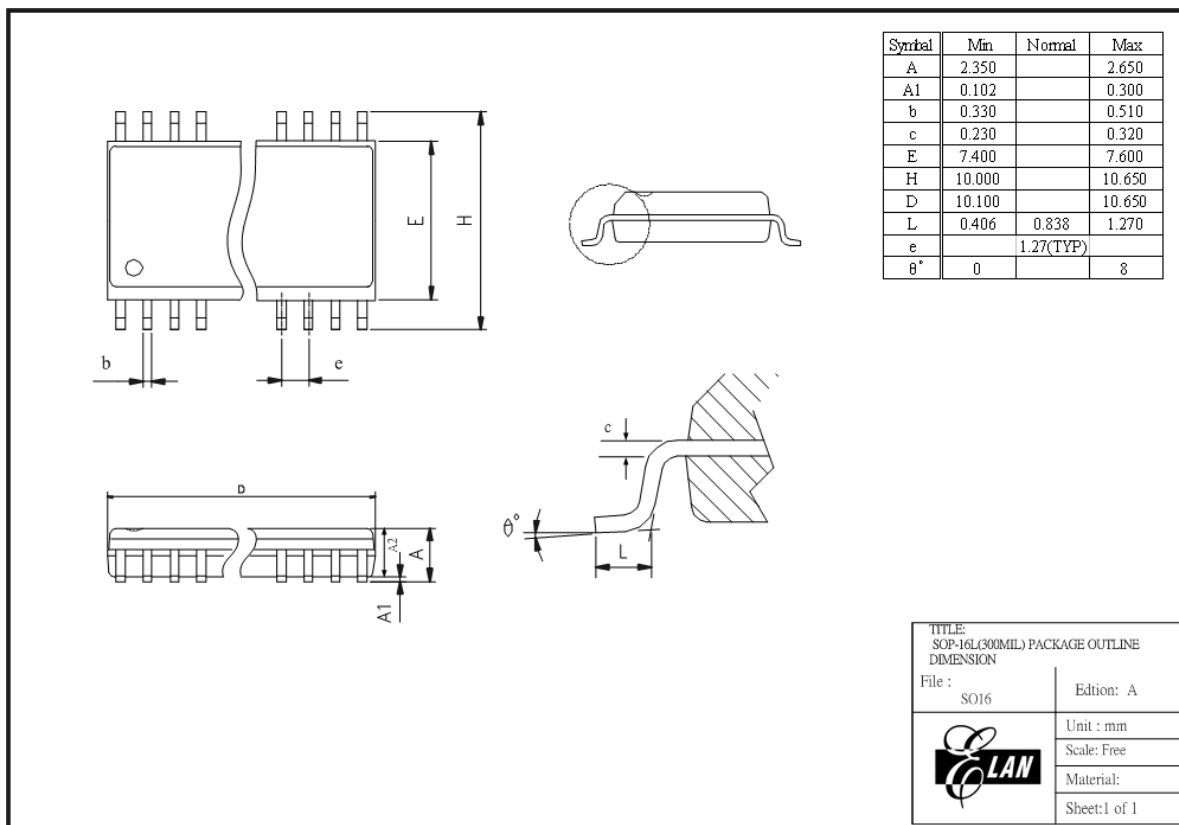

Figure C-2 EM78F562N/F662N 16-pin SOP Package Type

C.3 EM78F662NQN16A 4x4mm

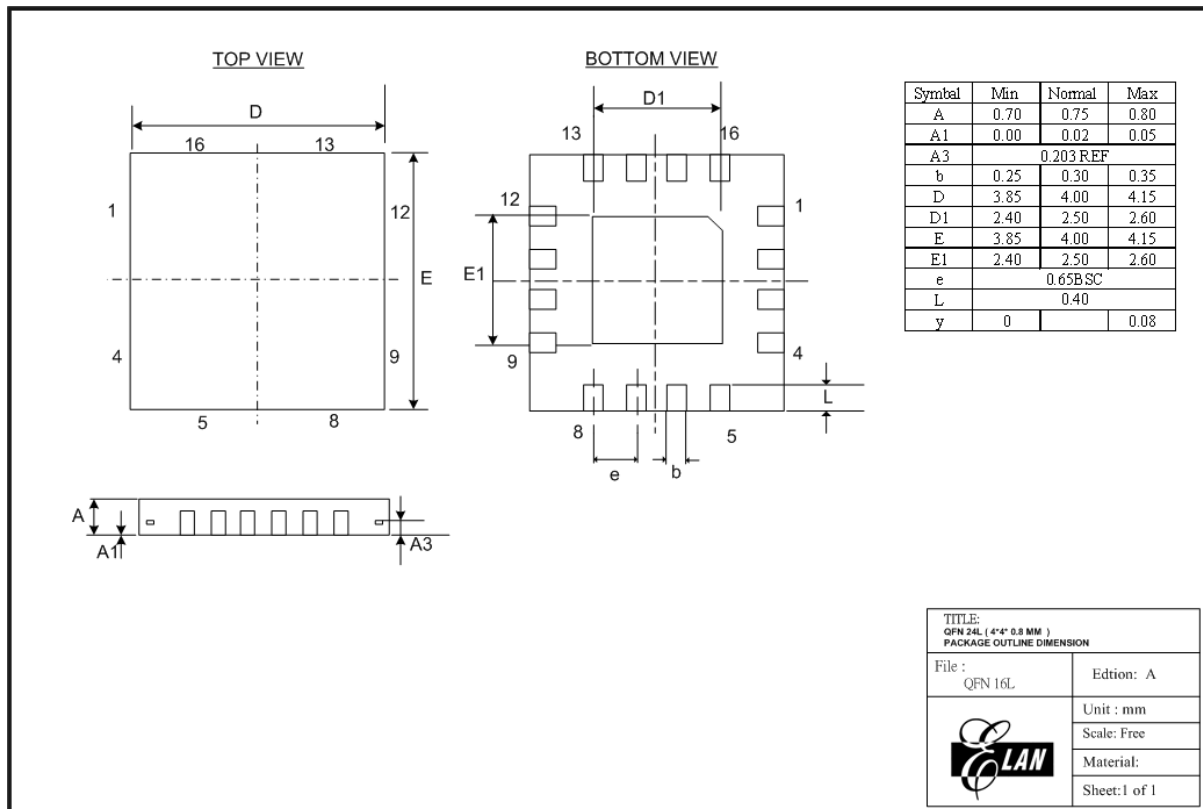

Figure C-3 EM78F662N 16-pin QFN Package Type

C.4 EM78F662NSS16 150mil

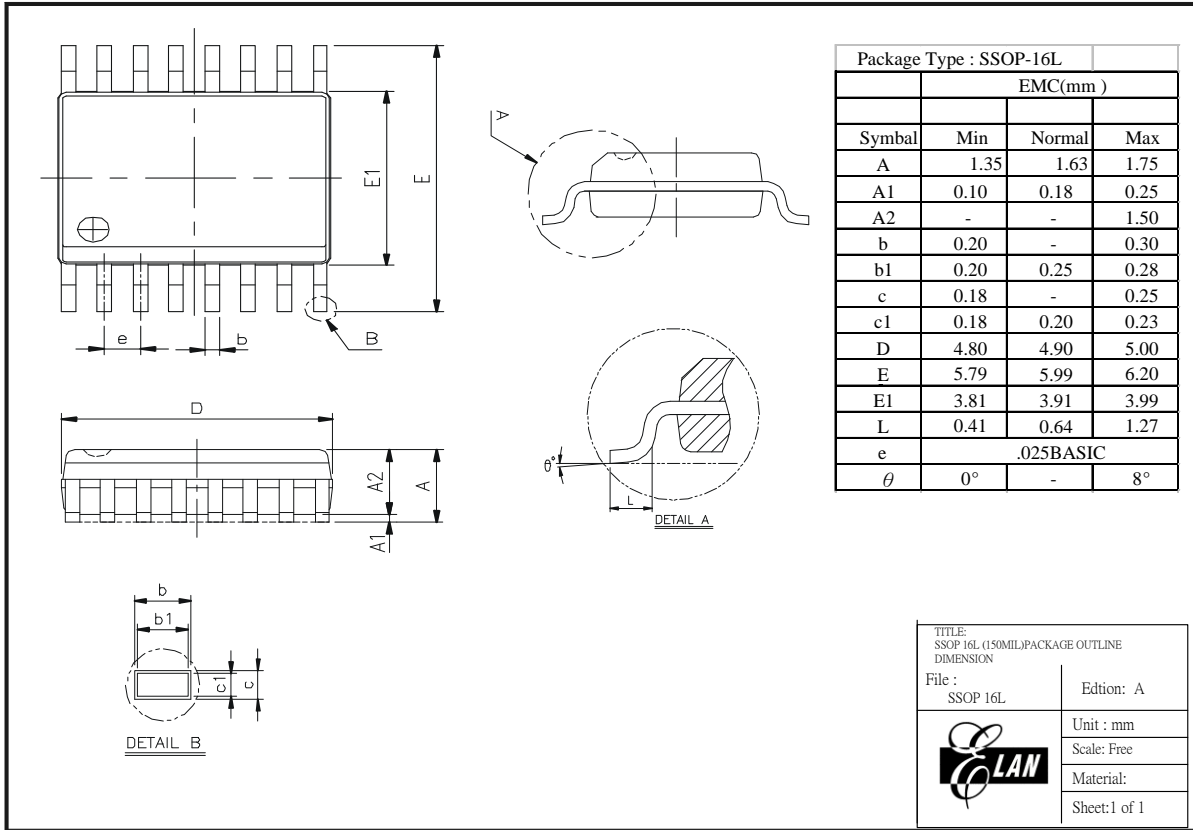

Figure C-4 EM78F662N 16-pin SSOP Package Type

C.5 EM78F562N/F662ND18 300mil

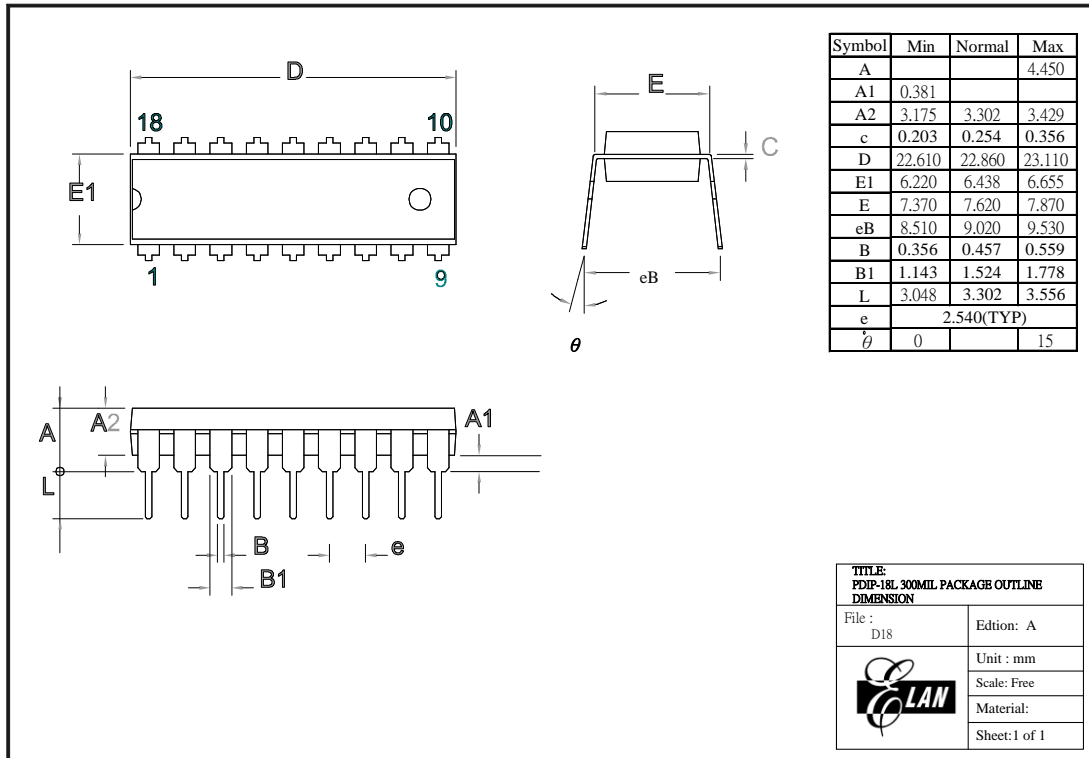

Figure C-5 EM78F562N/F6622N 18-pin PDIP Package Type

C.6 EM78F562N/F662NSO18 300mil

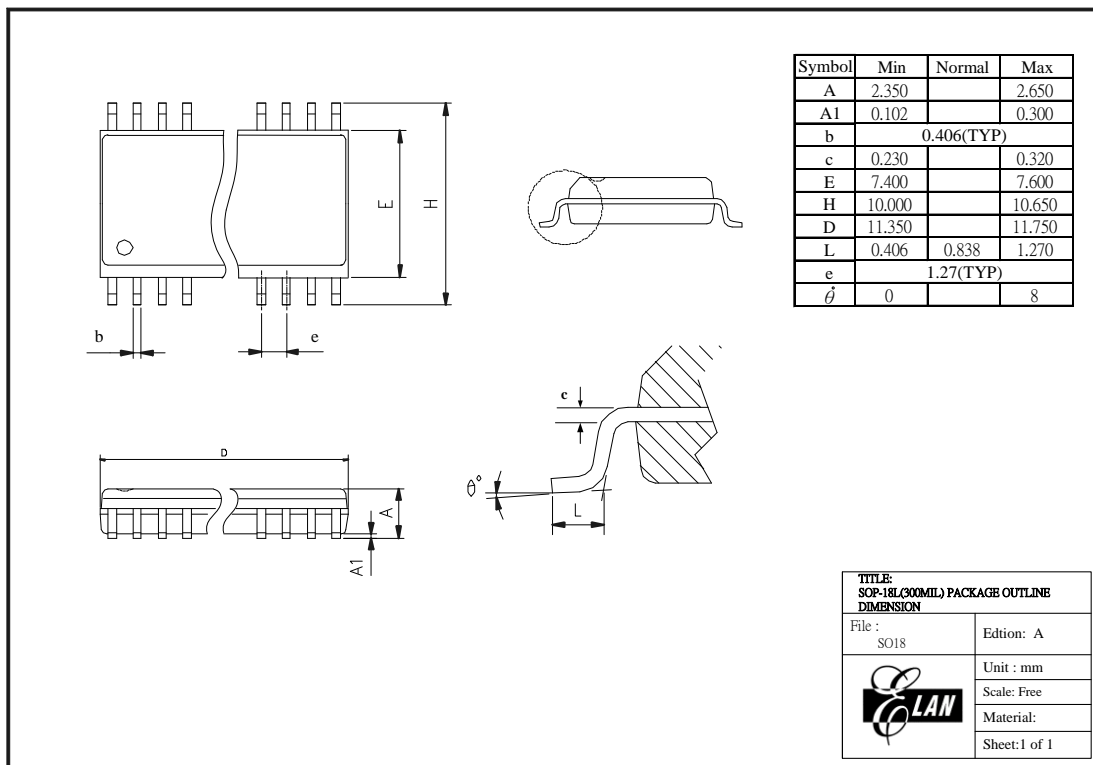

Figure C-6 EM78F562N/F6622N 18-pin SOP Package Typ

C.7 EM78F562N/F662ND20 300mil

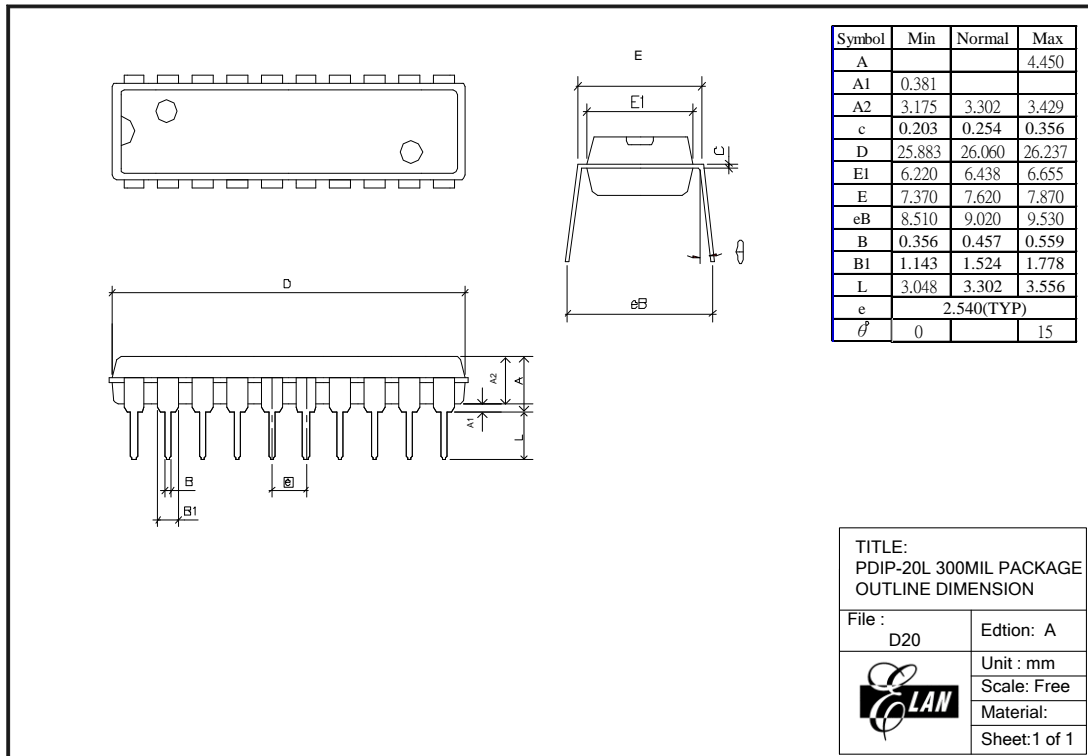

Figure C-7 EM78F562N/F662N 20-pin PDIP Package Type

C.8 EM78F562/F662NSO20 300mil

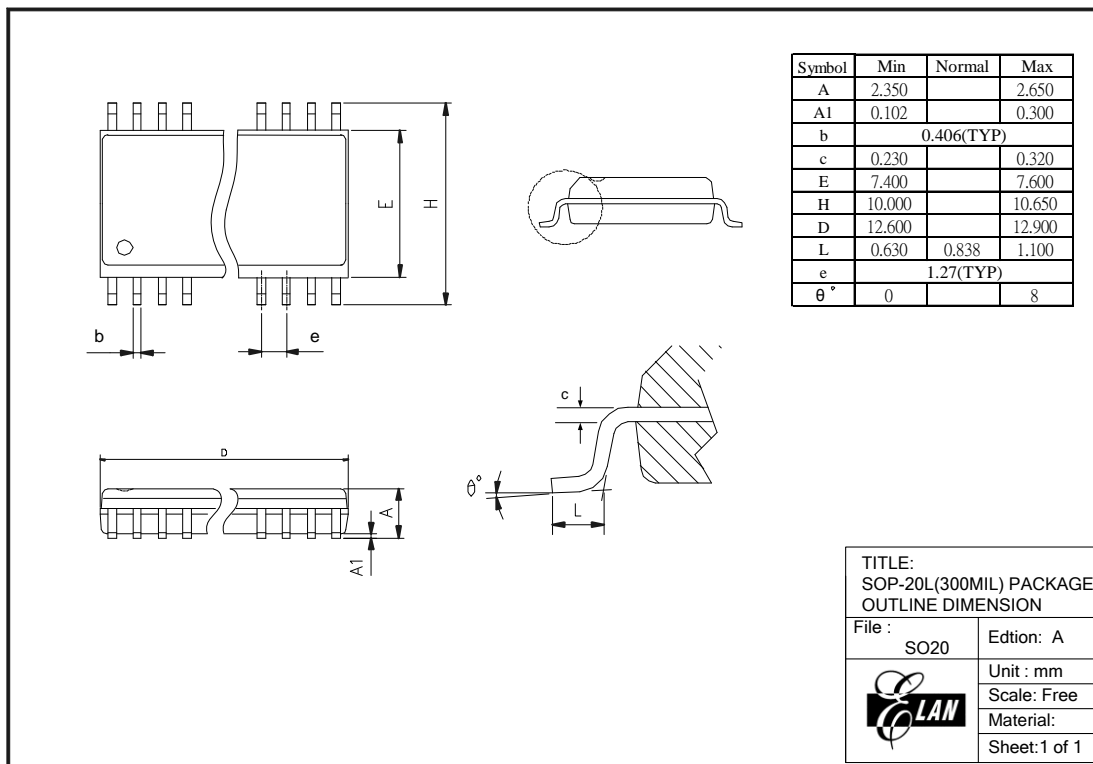

Figure C-8 EM78F562N/F662N 20-pin SOP Package Typ

D Quality Assurance and Reliability

Test Category	Test Conditions	Remarks
Solderability	Solder temperature= $245\pm 5^{\circ}\text{C}$, for 5 seconds up to the stopper using a rosin-type flux	–
Pre-condition	Step 1: TCT, 65°C (15mins)~ 150°C (15mins), 10 cycles	For SMD IC (such as SOP, QFP, SOJ, etc)
	Step 2: Bake at 125°C , TD (endurance)=24 hrs	
	Step 3: Soak at $30^{\circ}\text{C}/60\%$, TD (endurance)=192 hrs	
	Step 4: IR flow 3 cycles (Pkg thickness $\geq 2.5\text{mm}$ or Pkg volume $\geq 350\text{mm}^3$ ---- $225\pm 5^{\circ}\text{C}$) (Pkg thickness $\leq 2.5\text{mm}$ or Pkg volume $\leq 350\text{mm}^3$ ---- $240\pm 5^{\circ}\text{C}$)	
Temperature cycle test	-65°C (15mins)~ 150°C (15mins), 200 cycles	–
Pressure cooker test	TA = 121°C , RH=100%, pressure=2 atm, TD (endurance)= 96 hrs	–
High temperature / High humidity test	TA= 85°C , RH=85%, TD (endurance) = 168, 500 hrs	–
High-temperature storage life	TA= 150°C , TD (endurance) = 500, 1000 hrs	–
High-temperature operating life	TA= 125°C , VCC = Max. operating voltage, TD (endurance) = 168, 500, 1000 hrs	–
Latch-up	TA= 25°C , VCC = Max. operating voltage, 150mA/20V	–
ESD (HBM)	TA= 25°C , $\geq \pm 3\text{KV} $	IP_ND,OP_ND,IO_ND IP_NS,OP_NS,IO_NS IP_PD,OP_PD,IO_PD, IP_PS,OP_PS,IO_PS, VDD-VSS(+),VDD_VSS (-) mode
ESD (MM)	TA= 25°C , $\geq \pm 300\text{V} $	

D.1 Address Trap Detect

An address trap detect is one of the MCU embedded fail-safe functions that detects MCU malfunction caused by noise or the like. Whenever the MCU attempts to fetch an instruction from a certain section of ROM, an internal recovery circuit is auto started. If a noise-caused address error is detected, the MCU will repeat execution of the program until the noise is eliminated. The MCU will then continue to execute the next program.