

DP8481 TTL to 10k ECL Level Translator with Latch

General Description

This circuit translates TTL input levels to ECL output levels and provides a fall-through latch. The outputs are gated with CS providing for wire ORing of outputs. The strobe and chip select inputs operate at ECL levels.

Features

- 16-pin flat-pack or DIP
- ECL control inputs
- CS provided for wire ORing of output bus
- 10k ECL I/O compatible
- 3.0 ns typical propagation delay

Logic and Connection Diagram

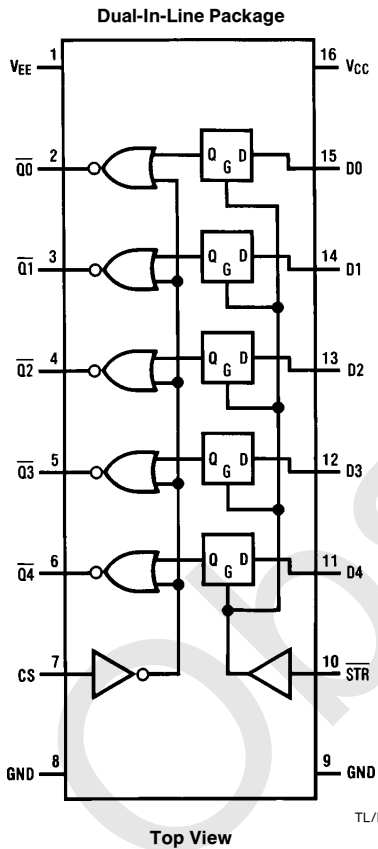

Truth Table

D	\bar{Q}	STR	CS
H	L	L	H
L	H	L	H
X	\bar{Q}	H	H
X	L	X	L

H = high level (most positive)
 L = low level (most negative)
 X = don't care

Order Number
 DP8481F, DP8481J or DP8481N
 See NS Package
 F16B, J16A or N16A

Absolute Maximum Ratings (Note 1)

If Military/Aerospace specified devices are required, please contact the National Semiconductor Sales Office/Distributors for availability and specifications.

V_{EE} Supply Voltage	-8V
V_{CC} Supply Voltage	7V
Input Voltage (ECL)	GND to V_{EE}
Input Voltage (TTL)	-1V to 5.5V
Output Current	50 mA
Maximum Power Dissipation* at 25°C	
Molded Package	1476 mW
Storage Temperature	-65°C to +150°C

*Derate molded package 11.8 mW/°C above 25°C.

Recommended Operating Conditions

V_{EE} Supply Voltage	-5.2V ± 10%
V_{CC} Supply Voltage	5.0V ± 10%
T_A , Ambient Temperature	0°C to 75°C

Electrical Characteristics (TTL Logic) (Notes 2 and 3)

Symbol	Parameter	Conditions	Min	Typ	Max	Units
V_{IL}	Input Low Voltage				0.8	V
V_{IH}	Input High Voltage		2.0			V
I_{IL}	Input Low Current	$V_{IN} = 0.5V$		-25	-200	μA
I_{IH}	Input High Current	$V_{IN} = 2.5V$		1.0	40	μA
V_{CLAMP}	Input Clamp Voltage	$I_{IN} = -12 mA$		-0.9	-1.2	V
I_{CC}	Supply Current	$V_{CC} = 5.5V$		10	20	mA

Electrical Characteristics (ECL Logic) (Notes 2 and 3)

Symbol	Parameter	Conditions	T_A	Min	Typ	Max	Units
V_{IL}	Input Low Voltage	$V_{EE} = -5.2V$	0°C 25°C 75°C	-1870 -1850 -1830		-1490 -1475 -1450	mV
V_{IH}	Input High Voltage	$V_{EE} = -5.2V$	0°C 25°C 75°C	-1145 -1105 -1045		-840 -810 -720	mV
I_{IL}	Input Low Current	$V_{IN} = -1.8V$			55	150	μA
I_{IH}	Input High Current	$V_{IN} = -0.8V$			85	200	μA
V_{OL}	Output Low Voltage	$V_{EE} = -5.2V$	0°C 25°C 75°C	-1870 -1850 -1830		-1665 -1650 -1625	mV
V_{OH}	Output High Voltage	$V_{EE} = -5.2V$	0°C 25°C 75°C	-1000 -960 -900		-840 -810 -720	mV
V_{OLC}	Output Low Voltage	$V_{EE} = -5.2V$	0°C 25°C 75°C			-1645 -1630 -1605	mV
V_{OHC}	Output High Voltage	$V_{EE} = -5.2V$	0°C 25°C 75°C	-1020 -980 -920			mV
I_{EE}	Supply Current	$V_{EE} = -5.7V$			-70	-90	mA

Switching Characteristics (Notes 2 and 4)

Symbol	Parameter	Conditions	Min	Typ	Max	Units
t_{PD1}	Strobe To Output Delay		1.5	3.0	6.0	ns
t_{PD2}	Data To Output Delay		2.5	4.5	7.5	ns
t_S	Data Set-Up Time to Strobe		5.0	2.0		ns
t_H	Data Hold Time		1.0	0		ns
t_{PW}	Strobe Pulse Width		5.0	3.0		ns
t_{PD3}	Chip Select to Output Delay		1.0	2.5	4.0	ns
t_{SCS}	Data Set-Up Time to Chip Select		5.5	3.0		ns

Note 1: "Absolute Maximum Ratings" are those values beyond which the safety of the device cannot be guaranteed. They are not meant to imply that the device should be operated at these limits. The table of "Electrical Characteristics" provides conditions for actual device operation.

Note 2: Unless otherwise specified, min/max limits apply across the 0°C to 75°C ambient temperature range in still air and across the specified supply variations. All typical values are for 25°C and nominal supply.

Note 3: All currents into device pins are shown as positive; all currents out of device pins are shown as negative. All voltages are referenced to ground, unless otherwise specified.

Note 4: Unless otherwise specified, all AC measurements are referenced from the 1.5V level of the TTL input and to/from the 50% point of the ECL signal and a 50Ω resistor to -2V is the load. ECL input rise and fall times are 2.0 ns ± 0.2 ns from 20% to 80%. TTL input characteristic is 0V to 3V with $t_r = t_f \leq 3$ ns measured from 10% to 90%.

Switching Time Waveforms

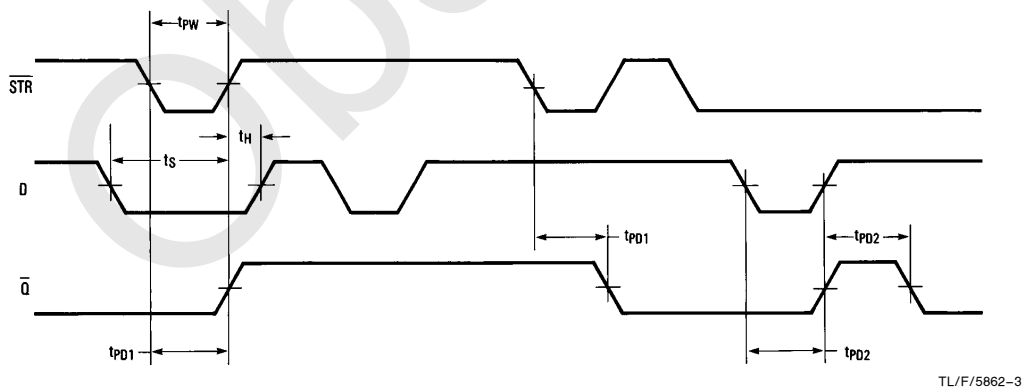
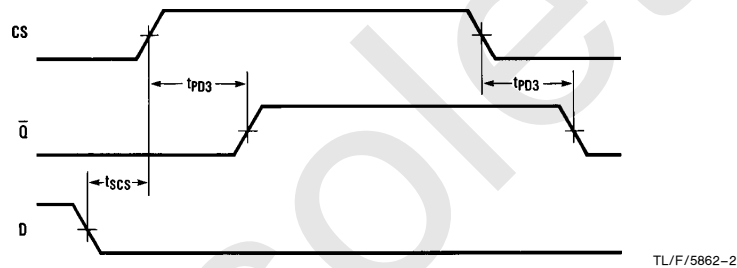

Obsolete

Physical Dimensions inches (millimeters) (Continued)

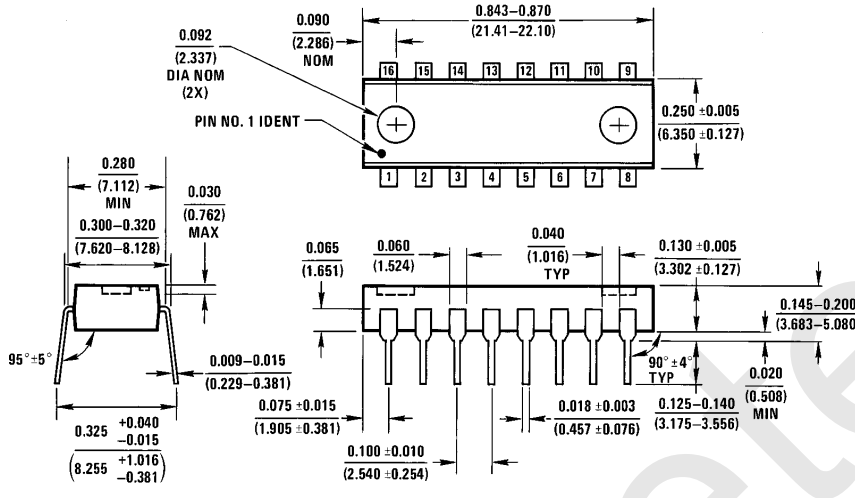

Molded Dual-In-Line Package (N)
Order Number DP8481N
NS Package N16A

N16A (REV E)

LIFE SUPPORT POLICY

NATIONAL'S PRODUCTS ARE NOT AUTHORIZED FOR USE AS CRITICAL COMPONENTS IN LIFE SUPPORT DEVICES OR SYSTEMS WITHOUT THE EXPRESS WRITTEN APPROVAL OF THE PRESIDENT OF NATIONAL SEMICONDUCTOR CORPORATION. As used herein:

1. Life support devices or systems are devices or systems which, (a) are intended for surgical implant into the body, or (b) support or sustain life, and whose failure to perform, when properly used in accordance with instructions for use provided in the labeling, can be reasonably expected to result in a significant injury to the user.
2. A critical component is any component of a life support device or system whose failure to perform can be reasonably expected to cause the failure of the life support device or system, or to affect its safety or effectiveness.



National Semiconductor Corporation
 1111 West Bardin Road
 Arlington, TX 76017
 Tel: 1(800) 272-9959
 Fax: 1(800) 737-7018

National Semiconductor Europe
 Fax: (+49) 0-180-530 85 86
 Email: cnjwge@tevm2.nsc.com
 Deutsch Tel: (+49) 0-180-530 85 85
 English Tel: (+49) 0-180-532 78 32
 Français Tel: (+49) 0-180-532 93 58
 Italiano Tel: (+49) 0-180-534 16 80

National Semiconductor Hong Kong Ltd.
 19th Floor, Straight Block,
 Ocean Centre, 5 Canton Rd.
 Tsimshatsui, Kowloon
 Hong Kong
 Tel: (852) 2737-1600
 Fax: (852) 2736-9960

National Semiconductor Japan Ltd.
 Tel: 81-043-299-2309
 Fax: 81-043-299-2408

National does not assume any responsibility for use of any circuitry described, no circuit patent licenses are implied and National reserves the right at any time without notice to change said circuitry and specifications.