

2-CHANNEL ELECTRONIC VOLUME

■ GENERAL DESCRIPTION

NJW1159 is a two channel electronic volume IC. It is included output buffer amplifier and also resistor output terminal for using external amplifier to customize for your application. These functions are controlled by three-wired serial data. And the chip selector is available for using four chips on same serial bus line. It's available for two-channel stereo and or multi-channel audio volume.

■ PACKAGE OUTLINE

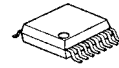

NJW1159V

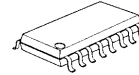

NJW1159M



NJW1159D

NRND Product

■ FEATURES

- Operating Voltage ±4.5 to ±7.5V
- Three-Wired Serial Data Control
- Chip Selector available for using four chips on same serial bus line.
- Volume 0 to -95dB/1dBstep, MUTE
- Bi-CMOS Technology
- Package Outline SSOP16, DMP16, DIP16

■ BLOCK DIAGRAM

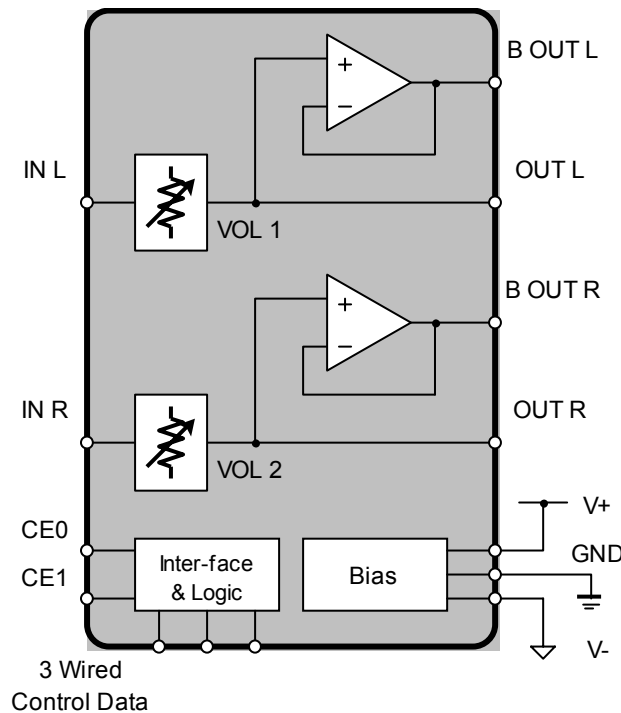

■ PIN ASSIGNMENT

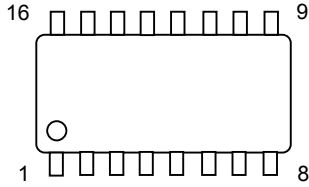

No.	Symbol	Function
1	OUTL	Lch External Opamp Input Connection Terminal
2	BOU TL	Lch Output
3	VDD_OUT	Internal VDD Noise Rejection Capacitor Terminal
4	BOU TR	Rch Output
5	OUTR	Rch External Opamp Input Connection Terminal
6	VSS_OUT	Internal VSS Noise Rejection Capacitor Terminal
7	V+	+ Power supply voltage input
8	V-	- Power supply voltage input
9	INL	Lch Input
10	INR	Rch Input
11	CE0	Chip Enable Terminal 0
12	CE1	Chip Enable Terminal 1
13	DATA	Control data signal input
14	CLOCK	Clock signal input
15	LACTH	Latch signal input
16	GND	Ground

■ ABSOLUTE MAXIMUM RATING (Ta=25°C)

PARAMETER	SYMBOL	RATING	UNIT
Power Supply Voltage	V ⁺ /V ⁻	+8/-8	V
Maximum Input Voltage	V _{IM}	V ⁺ /V ⁻ (*)	V
Power Dissipation	P _D	SSOP16 ; 300 DMP16 ; 300 DIP16 ; 500	mW
Operating Temperature Range	Topr	-40 to +85	°C
Storage Temperature Range	Tstg	-40 to +125	°C

(*) For the maximum input voltage less than V⁺/V⁻

■ ELECTRICAL CHARACTERISTICS (Ta=25°C, V⁺/V⁻ = +7V/-7V, R_L=47kΩ)

PARAMETER	SYMBOL	TEST CONDITION	MIN.	TYP.	MAX.	UNIT
◆ Power Supply						
Operating Voltage 1	V+		4.5	7.0	7.5	V
Operating Voltage 2	V-		-7.5	-7.0	-4.5	V
Supply Current 1	I _{CC}	No signal	-	4.5	9.0	mA
Supply Current 2	I _{EE}	No signal	-	4.5	9.0	mA
◆ Input/Output Characteristics (BOU TL : 2pin, BOU TR : 4pin)						
Maximum Output Voltage	V _{OM}	f=1kHz, THD=1% Volume=0dB	3.0	4.0	-	V _{rms}
Voltage Gain	G _V	V _{IN} =1V _{rms} , f=1kHz Volume=0dB	-0.5	0	0.5	dB
Channel Gain Balance 1	ΔG _{V1}	V _{IN} =1V _{rms} , f=1kHz Volume=0dB	-0.5	0	0.5	dB
Channel Gain Balance 2	ΔG _{V2}	V _{IN} =1V _{rms} , f=1kHz Volume=-60dB	-1.0	0	1.0	dB
Maximum Attenuation	A _{TT}	V _{IN} =1V _{rms} , f=1kHz Volume=-95dB, A-weight	-	-95	-	dB
Mute Level	Mute	V _{IN} =1V _{rms} , f=1kHz Volume=Mute, A-weight	-	-110	-	dB
Output Noise Voltage	V _{NO}	Volume=0dB, R _g =0Ω, A-weight	-	-105 (5.6μ)	-95 (17.8μ)	dBV (V _{rms})
Total Harmonic Distortion	THD	V _o =1V _{rms} , f=1kHz, Volume=0dB, BW=400-30kHz	-	0.005	0.05	%
Channel Separation	CS	V _o =1V _{rms} , f=1kHz, A-weight Volume=0dB, R _g =0Ω	-	-100	-90	dB

■ ELECTRICAL CHARACTERISTICS (Ta=25°C, V+ / V- = +7V / -7V)

PARAMETER	SYMBOL	TEST CONDITION	MIN.	TYP.	MAX.	UNIT
◆ Logic Control Characteristics						
High Level Input Voltage	V _{IH}	DATA, CLOCK, LATCH, CE0, CE1 Terminal Input	2.5	-	5.5	V
Low Level Input Voltage	V _{IL}	DATA, CLOCK, LATCH, CE0, CE1 Terminal Input	0	-	1.5	V

■ CONTROL DATA FORMAT

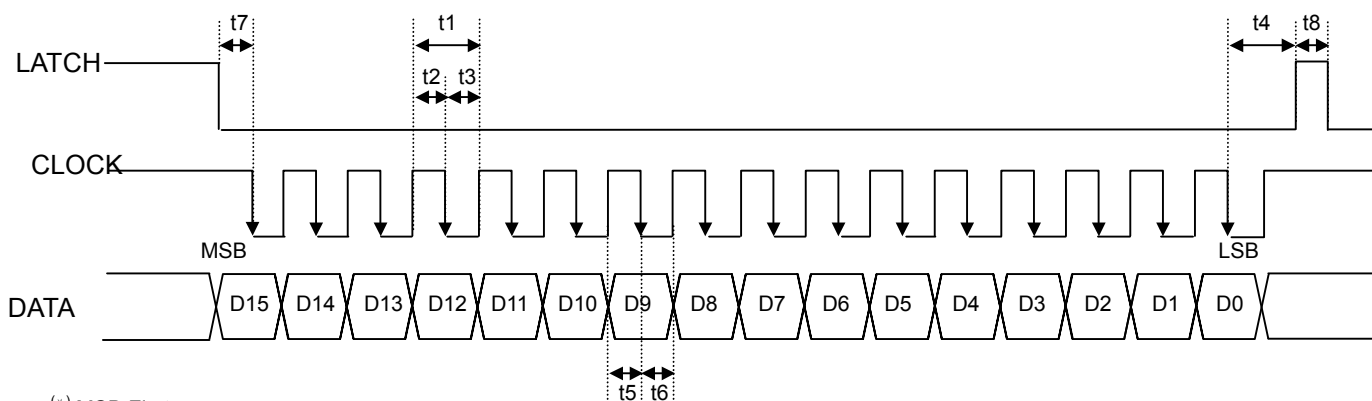

(*) MSB First

SYMBOL	PARAMETER	MIN	TYP	MAX	UNIT
t1	CLOCK Clock Width	2	-	-	μsec
t2	CLOCK Pulse Width (High)	0.8	-	-	μsec
t3	CLOCK Pulse Width (Low)	0.8	-	-	μsec
t4	LATCH Rise Hold Time	1.6	-	-	μsec
t5	DATA Setup Time	0.8	-	-	μsec
t6	DATA Hold Time	0.8	-	-	μsec
t7	CLOCK Setup Time	0.8	-	-	μsec
t8	LATCH High Pulse Width	1.6	-	-	μsec

■ TERMINAL DESCRIPTION

PIN NO.	SYMBOL	FUNCTION	EQUIVALENT CIRCUIT	TERMINAL DC VOLTAGE
3 6	VDD_OUT VSS_OUT	Internal VDD Noise Rejection Capacitor Terminal Internal VSS Noise Rejection Capacitor Terminal		2.5V (VDD_OUT) -2.5V (VSS_OUT)
1 5	OUTL OUTR	Lch External Opamp Input Connection Terminal Rch External Opamp Input Connection Terminal		0V 0V
2 4	BOUTL BOUTR	Lch Output Rch Output		0V 0V
7	V+	+Power Supply Voltage Input		V+

■ TERMINAL DESCRIPTION

PIN NO.	SYMBOL	FUNCTION	EQUIVALENT CIRCUIT	TERMINAL DC VOLTAGE
9 10	INL INR	Lch Input Rch Input		0V
11 12 13 14 15	CE0 CE1 DATA CLOCK LATCH	Chip Enable Terminal 0 Chip Enable Terminal 1 Control data signal input Clock signal input Latch signal input		0V
16	GND	Ground		0V

■ APPLICATION CIRCUIT

1. Internal Output Buffer Application

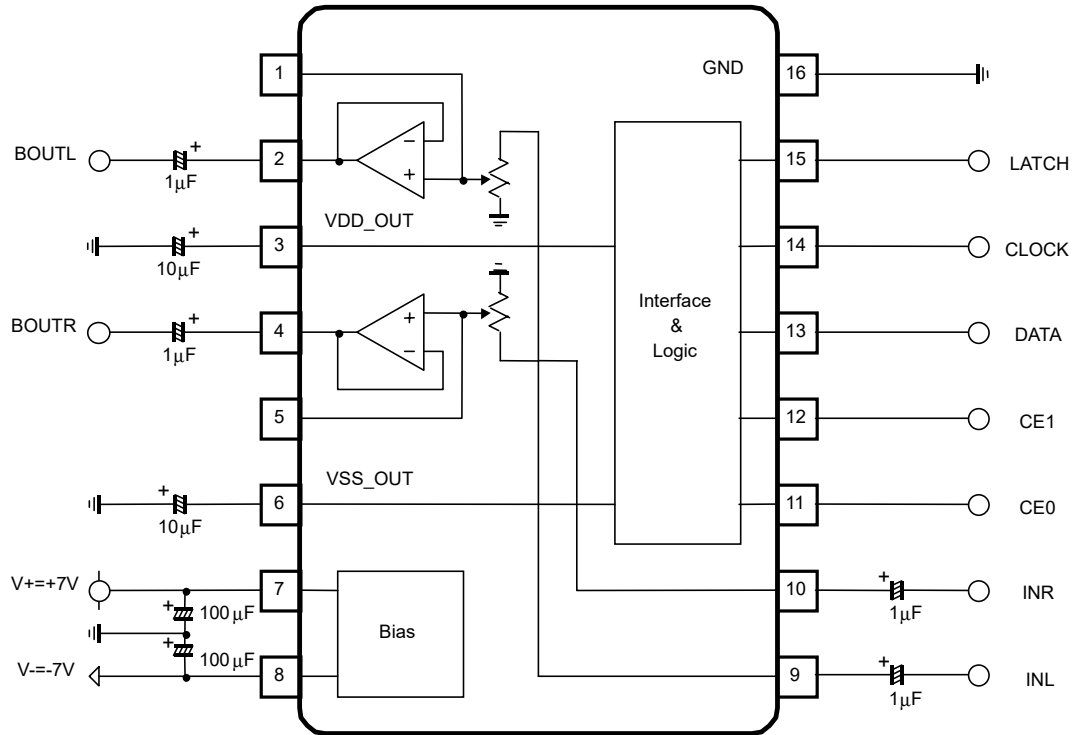

(*) DATA, CLOCK, LATCH are digital lines.
 Separate the DATA, CLOCK, LATCH lines and Analog signal terminals (especially, 1pin, 5pin, 9pin, 10pin) for avoiding digital noise problem and cross talk.

2. External Output Buffer Application (JFET Input type OP Amp.)

Ex.) $G_v = +15\text{dB}$

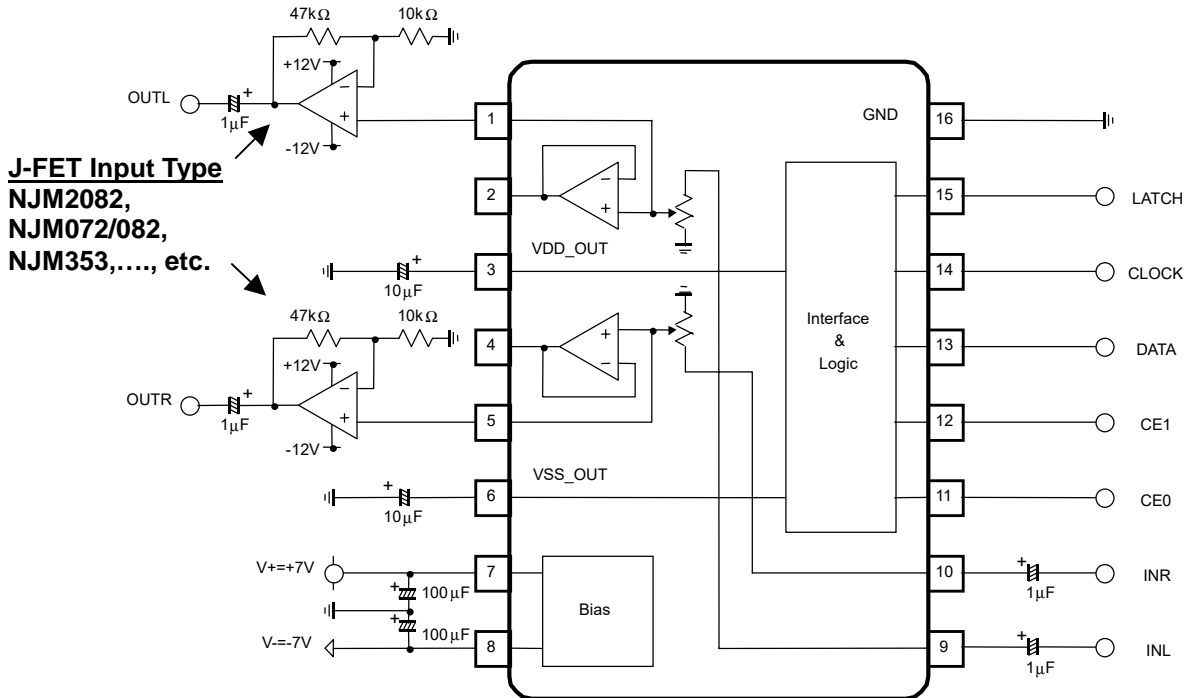

(*) DATA, CLOCK, LATCH are digital lines.
 Separate the DATA, CLOCK, LATCH lines and Analog signal terminals (especially, 1pin, 5pin, 9pin, 10pin) for avoiding digital noise problem and cross talk.

■ CONTROL DATA

NJW1159 is controlled by 16-bits serial data.

MSB															LSB
D15	D14	D13	D12	D11	D10	D9	D8	D7	D6	D5	D4	D3	D2	D1	D0
Data								Select Address				Chip Address			

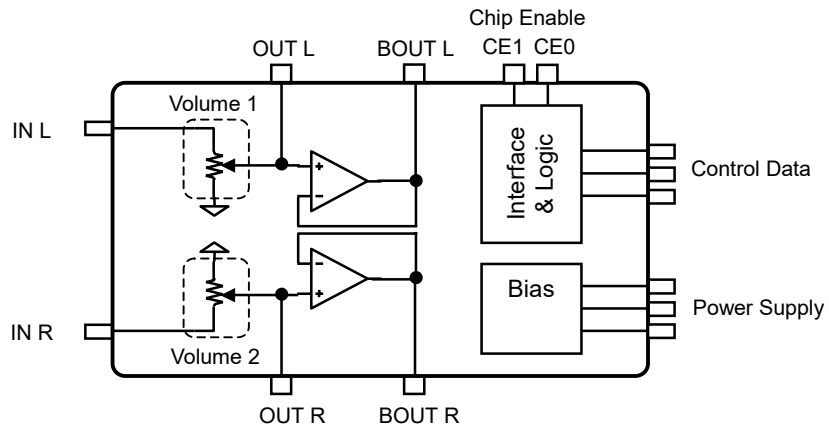

MSB															LSB
D15	D14	D13	D12	D11	D10	D9	D8	D7	D6	D5	D4	D3	D2	D1	D0
Volume 1							Don't Care	0	0	0	0	*	*	*	*
Volume 2							Don't Care	0	0	0	1	*	*	*	*

* Chip address is set by chip enable terminal (CE0, CE1) status.

Chip enable Terminal		Chip Address			
CE1	CE0	D3	D2	D1	D0
0	0	0	0	0	0
0	1	0	0	0	1
1	0	0	0	1	0
1	1	0	0	1	1

■ INITIAL CONDITION

MSB															LSB
D15	D14	D13	D12	D11	D10	D9	D8	D7	D6	D5	D4	D3	D2	D1	D0
1	1	1	1	1	1	1	1	0	0	0	0	*	*	*	*
1	1	1	1	1	1	1	1	0	0	0	1	*	*	*	*

■ DEFINITION OF RESISTOR

◆ Volume 1 , Volume 2 : 0 to -95dB(1dB/step)

D15	D14	D13	D12	D11	D10	D9	D8	D7	D6	D5	D4	D3	D2	D1	D0
Volume 1							Don't Care	0	0	0	0	*	*	*	*
Volume 2							Don't Care	0	0	0	1	*	*	*	*

< Volume Control >

Data							Setting
D15	D14	D13	D12	D11	D10	D9	
0	0	0	0	0	0	0	0dB
0	0	0	0	0	0	1	-1dB
0	0	0	0	0	1	0	-2dB
0	0	0	0	0	1	1	-3dB
0	0	0	0	1	0	0	-4dB
0	0	0	0	1	0	1	-5dB
0	0	0	0	1	1	0	-6dB
0	0	0	0	1	1	1	-7dB
0	0	0	1	0	0	0	-8dB
0	0	0	1	0	0	1	-9dB
0	0	0	1	0	1	0	-10dB
0	0	0	1	0	1	1	-11dB
0	0	0	1	1	0	0	-12dB
0	0	0	1	1	0	1	-13dB
0	0	0	1	1	1	0	-14dB
0	0	0	1	1	1	1	-15dB
0	0	1	0	0	0	0	-16dB
0	0	1	0	0	0	1	-17dB
0	0	1	0	0	1	0	-18dB
0	0	1	0	0	1	1	-19dB
0	0	1	0	1	0	0	-20dB
0	0	1	0	1	0	1	-21dB
0	0	1	0	1	1	0	-22dB
0	0	1	0	1	1	1	-23dB
0	0	1	1	0	0	0	-24dB
0	0	1	1	0	0	1	-25dB
0	0	1	1	0	1	0	-26dB
0	0	1	1	0	1	1	-27dB
0	0	1	1	1	0	0	-28dB
0	0	1	1	1	0	1	-29dB
0	0	1	1	1	1	0	-30dB
0	0	1	1	1	1	1	-31dB
0	1	0	0	0	0	0	-32dB
0	1	0	0	0	0	1	-33dB
0	1	0	0	0	1	0	-34dB
0	1	0	0	0	1	1	-35dB
0	1	0	0	1	0	0	-36dB
0	1	0	0	1	0	1	-37dB
0	1	0	0	1	1	0	-38dB
0	1	0	0	1	1	1	-39dB
0	1	0	1	0	0	0	-40dB
0	1	0	1	0	0	1	-41dB
0	1	0	1	0	1	0	-42dB
0	1	0	1	0	1	1	-43dB
0	1	0	1	1	0	0	-44dB
0	1	0	1	1	0	1	-45dB
0	1	0	1	1	1	0	-46dB
0	1	0	1	1	1	1	-47dB
0	1	1	0	0	0	0	-48dB
0	1	1	0	0	0	1	-49dB
0	1	1	0	0	1	0	-50dB

Data							Setting
D15	D14	D13	D12	D11	D10	D9	
0	1	1	0	0	1	1	-51dB
0	1	1	0	1	0	0	-52dB
0	1	1	0	1	0	1	-53dB
0	1	1	0	1	1	0	-54dB
0	1	1	0	1	1	1	-55dB
0	1	1	1	0	0	0	-56dB
0	1	1	1	0	0	1	-57dB
0	1	1	1	0	1	0	-58dB
0	1	1	1	0	1	1	-59dB
0	1	1	1	1	0	0	-60dB
0	1	1	1	1	0	1	-61dB
0	1	1	1	1	1	0	-62dB
0	1	1	1	1	1	1	-63dB
1	0	0	0	0	0	0	-64dB
1	0	0	0	0	0	1	-65dB
1	0	0	0	0	1	0	-66dB
1	0	0	0	0	1	1	-67dB
1	0	0	0	1	0	0	-68dB
1	0	0	0	1	0	1	-69dB
1	0	0	0	1	1	0	-70dB
1	0	0	0	1	1	1	-71dB
1	0	0	1	0	0	0	-72dB
1	0	0	1	0	0	1	-73dB
1	0	0	1	0	1	0	-74dB
1	0	0	1	0	1	1	-75dB
1	0	0	1	1	0	0	-76dB
1	0	0	1	1	0	1	-77dB
1	0	0	1	1	1	0	-78dB
1	0	0	1	1	1	1	-79dB
1	0	1	0	0	0	0	-80dB
1	0	1	0	0	0	1	-81dB
1	0	1	0	0	1	0	-82dB
1	0	1	0	0	1	1	-83dB
1	0	1	0	1	0	0	-84dB
1	0	1	0	1	0	1	-85dB
1	0	1	0	1	1	0	-86dB
1	0	1	0	1	1	1	-87dB
1	0	1	1	0	0	0	-88dB
1	0	1	1	0	0	1	-89dB
1	0	1	1	0	1	0	-90dB
1	0	1	1	0	1	1	-91dB
1	0	1	1	1	0	0	-92dB
1	0	1	1	1	0	1	-93dB
1	0	1	1	1	1	0	-94dB
1	0	1	1	1	1	1	-95dB
1	1	1	1	1	1	1	MUTE ^(*)

(*) Initial Setting

■ TYPICAL CHARACTERISTICS

Operating Current vs. Power Supply voltage

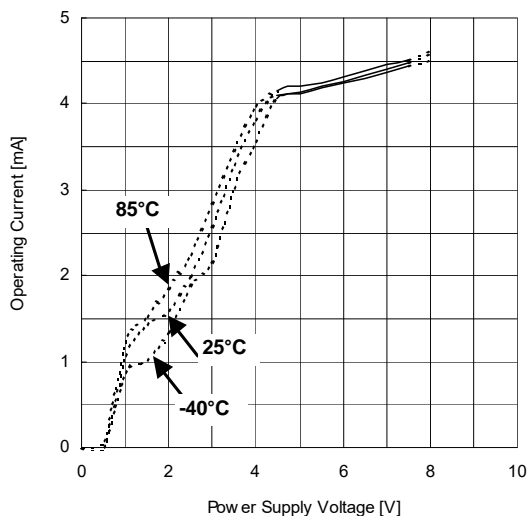

Operating Current vs. Ambient temperature
V+/V- = ±7V, ICC

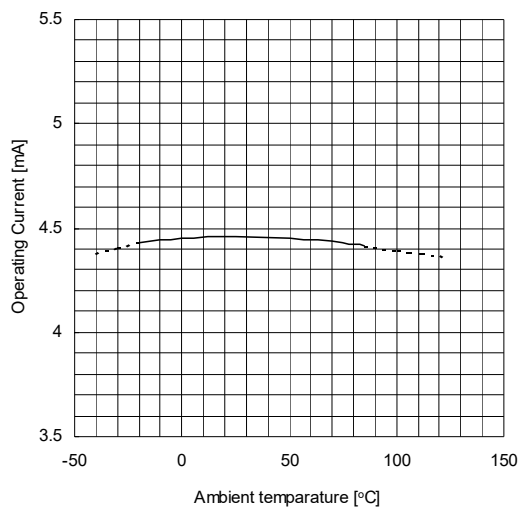

Maximum Output Voltage vs. Frequency
V+/V- = ±7V, THD=1%

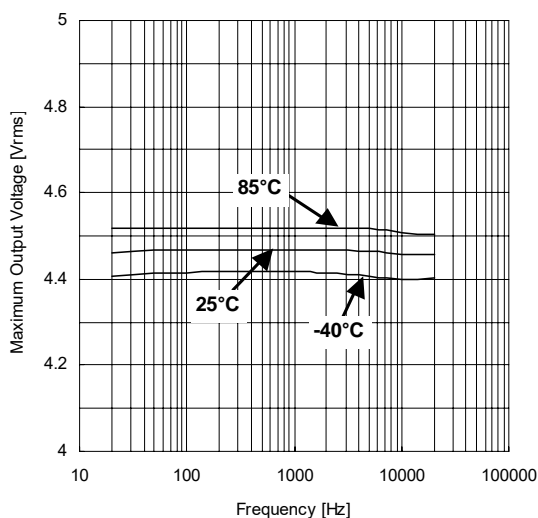

Maximum Output Voltage vs. Ambient temperature
V+/V- = ±7V, THD=1%

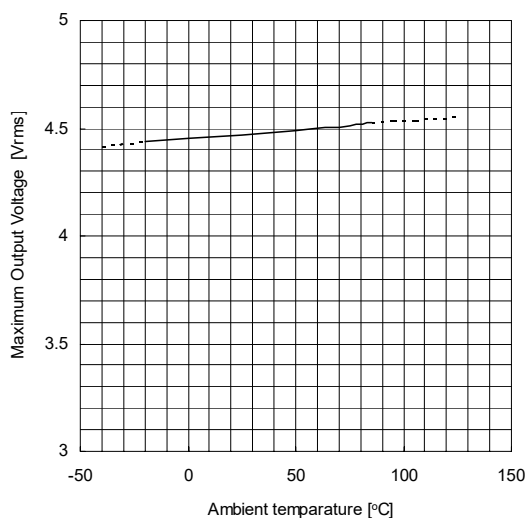

Voltage Gain vs. Ambient temperature
V+/V- = ±7V, Vin=0dBV, f=1kHz, RL=10kΩ

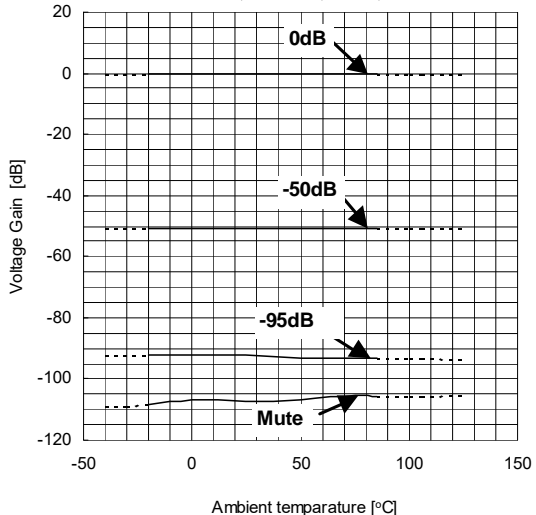

Voltage Gain vs. Gain set level
V+/V- = ±7V, Vin=0dBV, f=1kHz, RL=10kΩ

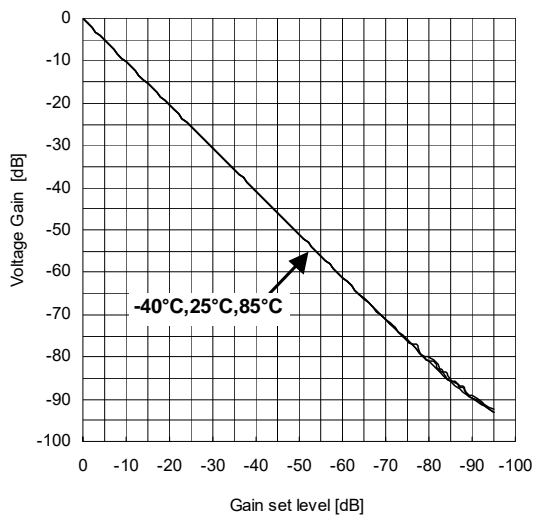

■ TYPICAL CHARACTERISTICS

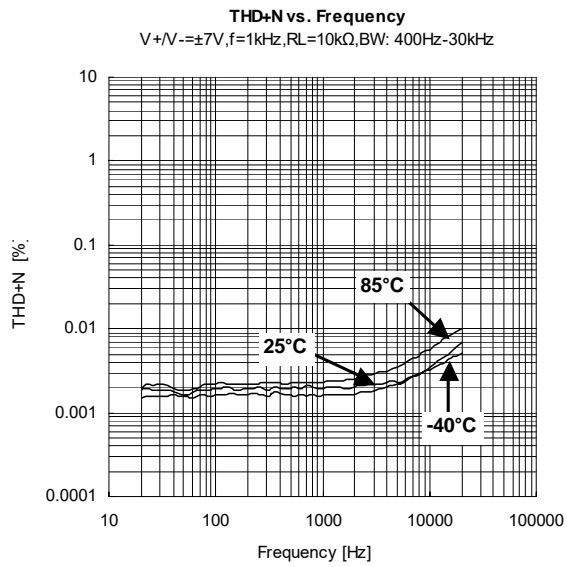
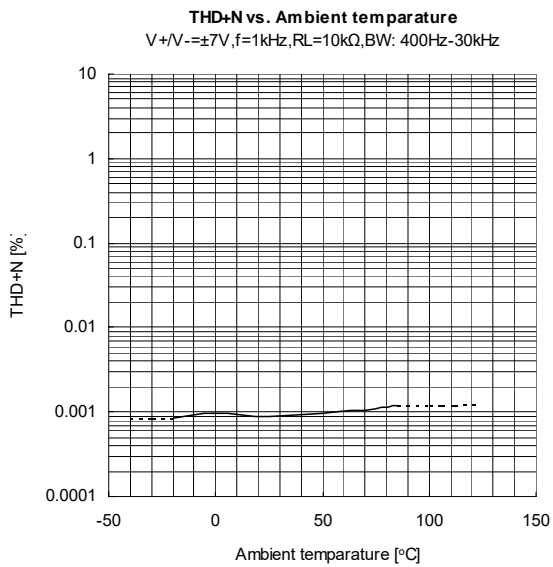
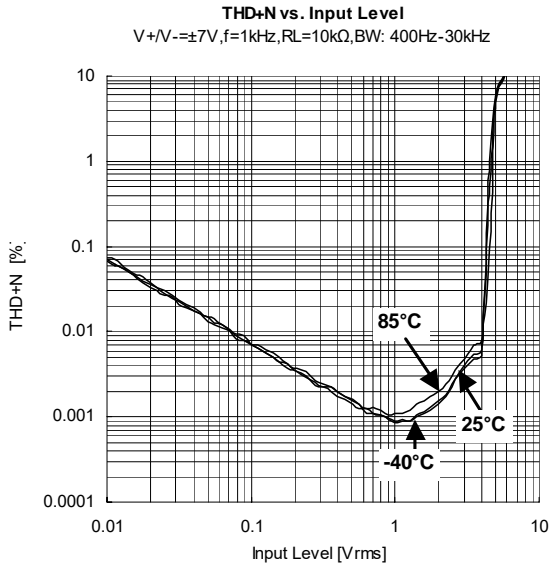
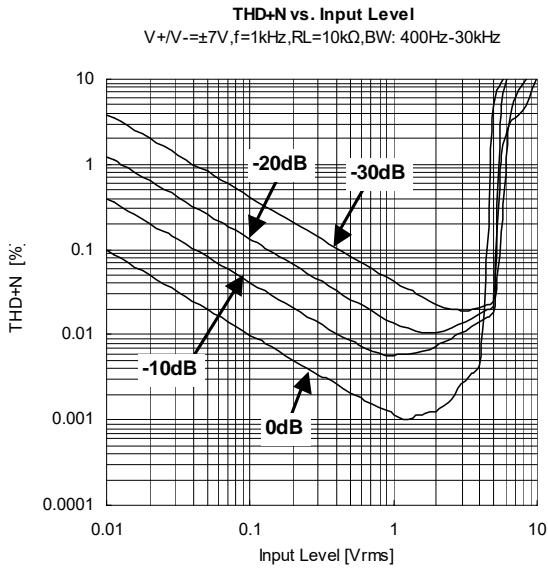
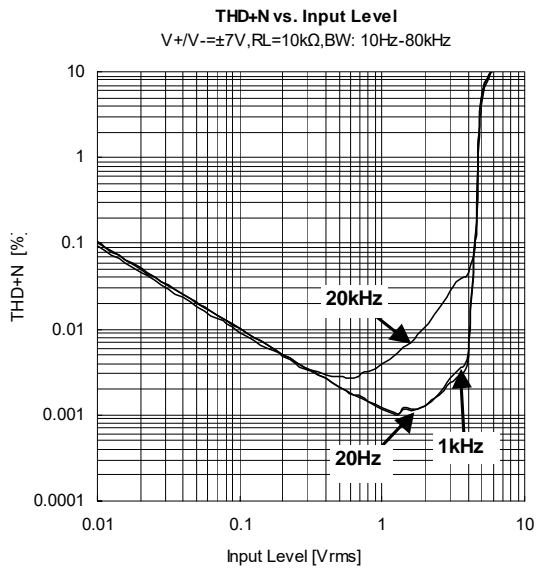
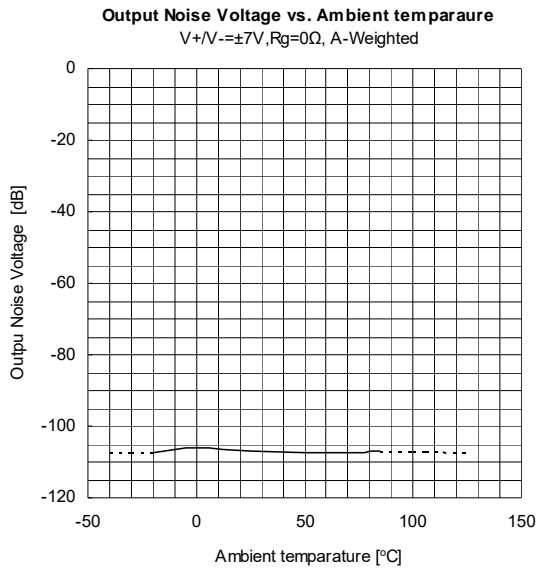

[CAUTION]

The specifications on this databook are only given for information , without any guarantee as regards either mistakes or omissions. The application circuits in this databook are described only to show representative usages of the product and not intended for the guarantee or permission of any right including the industrial rights.