



Product Description

Sirenza Microdevices' SFT-0100 is a high performance heterojunction bipolar transistor transimpedance amplifier designed for 10/12.5 Gb/s SONET/SDH applications. The SFT-0100 uses high F_T indium gallium phosphide device technology that delivers high transimpedance, large dynamic range, and a typical bandwidth greater than 10.5GHz.

Performance is enhanced through the use of a patented circuit topology that reduces duty cycle distortion under high photocurrent conditions and allows high transimpedance with low DC power to be realized. The SFT-0100 is supplied in bare die form and includes a current monitor feature that can be used for fiber alignment or loss of signal (LOS) detection.

Functional Block Diagram

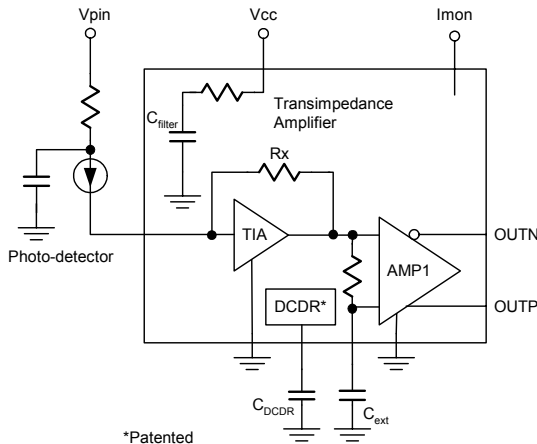

Preliminary Data Sheet

SFT-0100

Transimpedance Amplifier

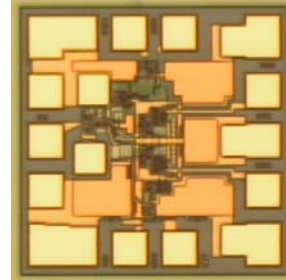

Chip Size: 1000um x 1000um x 100um

Product Features

- Low noise InGaP HBT technology
- Differential transimpedance $\sim 2200 \Omega$
- +5.0V power supply
- High sensitivity $< 10 \text{pA}/\sqrt{\text{Hz}}$
- Adjustable dynamic range
- Low duty-cycle distortion
- Differential Outputs
- Photo current monitor
- Patented DCDR circuit
- Backside vias eliminate the need for ground wirebonds

Applications

- Optical Receiver Modules
- XFP, XENPAK, XPAK, X2 modules
- 9.953 Gb/s SONET OC-192/SDH STM-64
- 10.3 Gb/s Ethernet Applications
- 10.7 Gb/s ITU G.709
- 12.5 Gb/s SONET with FEC

The information provided herein is believed to be reliable at press time. Sirenza Microdevices assumes no responsibility for inaccuracies or omissions. Sirenza Microdevices assumes no responsibility for the use of this information, and all such information shall be entirely at the user's own risk. Prices and specifications are subject to change without notice. No patent rights or licenses to any of the circuits described herein are implied or granted to any third party. Sirenza Microdevices does not authorize or warrant any Sirenza Microdevices product for use in life-support devices and/or systems.

Copyright 2002 Sirenza Microdevices, Inc. All worldwide rights reserved.
522 Almanor Ave., Sunnyvale, CA 94085

Phone: (800) SMI-MMIC

<http://www.sirenza.com>
EDS-102714 Rev. C

Absolute Maximum Ratings

Parameters	Value	Unit
Supply Current (I_{CC})	60	mA
Device Voltage (V_{CC})	6.0	V
Maximum DC Input Current	5.0	mA
Operating Temperature (T_{OP})	0 to +85	°C
Storage Temperature Range	-40 to +150	°C
Operating Junction Temperature (T_J)	+150	°C

Model Used For Transimpedance Calculation

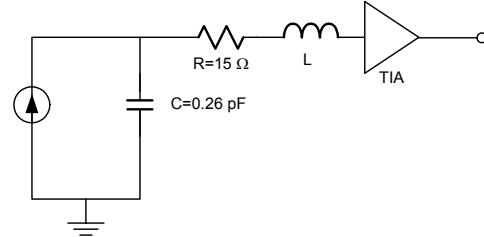

Product Specifications – Electrical

Parameters		Unit	Min.	Typ.	Max.
Differential Transimpedance	Assume $C_D = 0.26\text{pF}$, $R_D = 15\Omega$, $L_{INT} = 1.0\text{nH}$	Ω	2000	2200	2400
Transimpedance Bandwidth (3dB)	Assume $C_D = 0.26\text{pF}$, $R_D = 15\Omega$, $L_{INT} = 1.0\text{nH}$	GHz	9	10.5	
Gain	Single-ended, 50 Ω In/Out	dB	26	27.5	30
Gain Ripple	Single-ended, 50 Ω In/Out	dB		1	
S21 3dB Bandwidth	Single-ended, 50 Ω In/Out	GHz	8	9.5	
Group Delay Deviation	Single-ended, 50 Ω In/Out, 30kHz - F_C	ps		30	
Optical Sensitivity	Assuming 0.8A/W responsivity, measured at 10^{-10} BER with a $2^{23}-1$ PRBS @ 10Gb/s	dBm		-18.5	
Optical Overload	Assuming 0.8A/W responsivity, measured at 10^{-10} BER with a $2^{23}-1$ PRBS @ 10Gb/s	mA p-p		2.5	
Input Equivalent Noise Current Density	$F = 7\text{GHz}$	pA/ $\sqrt{\text{Hz}}$		9	
Maximum Output Voltage Swing	Single-ended, 50 Ω In/Out	mV p-p		450	
Input DC Voltage		V		1.45	
Output DC Voltage	50 Ω termination to V_{CC}	V		4.4	
Output Return Loss	Single-ended, 50 Ω In/Out	dB		-10	
Supply Voltage		V	4.75	5.0	5.25
Supply Current	$V_{CC}=5.0\text{V}$	mA	47	52	55
Power Dissipation		mW		260	
Input Coupling		AC or DC		DC	
Output Type		SE or DF		DF	
Output Coupling		AC or DC		AC or DC	
Photodiode Current Monitor				Yes	
Dynamic Range Adjust	See DCDR description			Yes	

Typical Electrical Performance

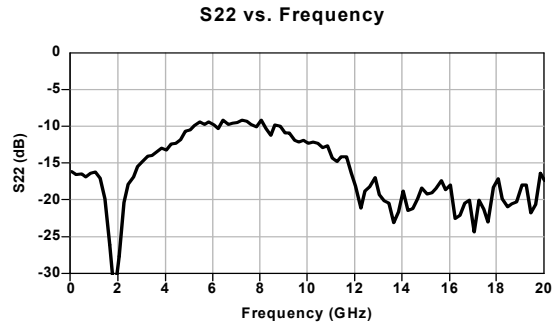
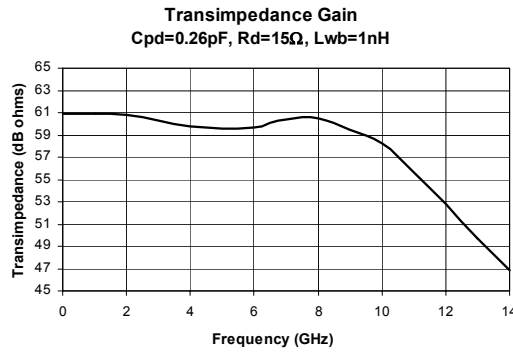
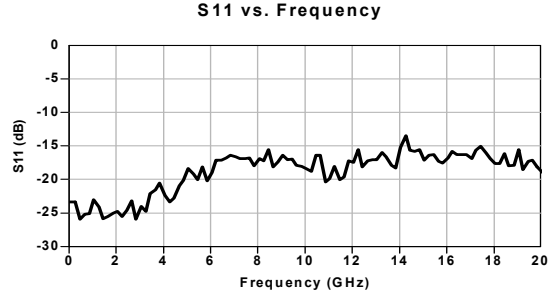
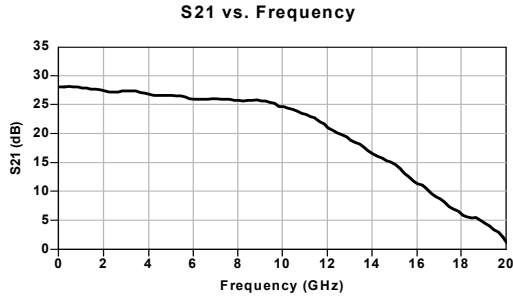

Note: All electrical measurements performed using die probe station.

Optical Measurement Performance

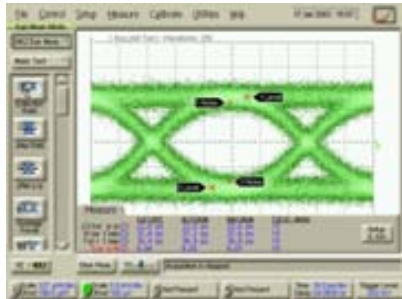

9.953Gb/s, -18dBm, PRBS31
Optical measurements courtesy of VSK Photonics

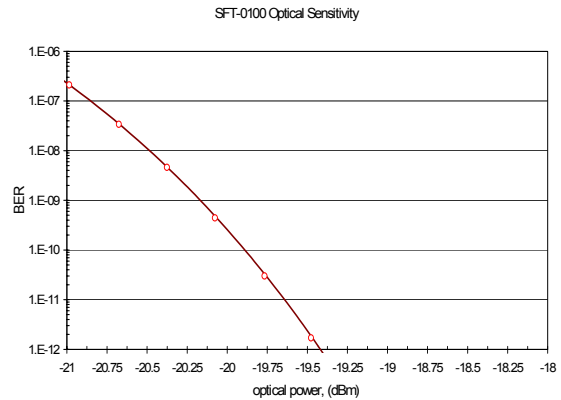

Application Circuit

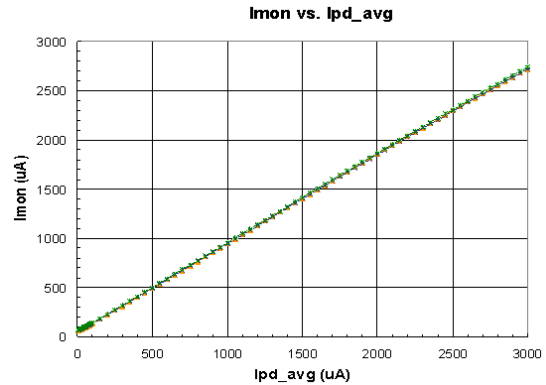
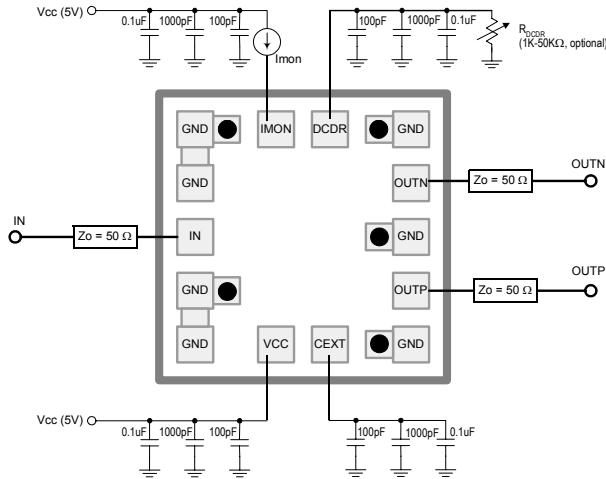

Description of External Connections and How They Operate

I_{mon}: When tied to the supply voltage through an ammeter, the current through the ammeter “I_{mon}” reflects the average photo diode current. The I_{mon} current will be approximately the value of the average photo diode current and will be directly proportional to this quantity. I_{mon} can be used for loss of signal detection or photodiode/fiber alignment in manufacturing. A third function this monitor can provide is the manual adjustment of the DCDR threshold. With no input photocurrent applied to the TIA, the I_{mon} will give a finite quiescent current (uA). The finite current indicates that the automatic circuit has already started to turn on. By employing a shunt resistor (1K-50K) on the C_{DCDR} port to ground, this threshold can be reduced (current can be reduced to a few uA) setting the automatic circuit for maximum sensitivity and dynamic range.

DCDR (Duty Cycle Distortion Reduction): This patented feature compensates for the duty cycle distortion as a result of high input current seen by the amplifier. As the optical input power and induced photo current is increased, an automatic circuit is invoked to prevent distorted operation in the transistors of the TIA. The threshold input current where the circuit turns on can be adjusted by employing a shunt resistor to ground at the DCDR pin. The value of the shunt resistor can be set between 1K and 50K. The lower the value, the higher the input current

threshold in which the circuit turns on. In order to optimize for maximum sensitivity and dynamic range, the I_{mon} current can be monitored while tuning this shunt resistor. Optimum sensitivity and dynamic range can be obtained by tuning the resistor value until only a few uA of I_{mon} current is observed when there is no optical input power applied.

C_{DCDR}: An off chip capacitor is required in order to integrate and produce the automatic circuit control voltage.

C_{EXT}: An off chip capacitor sets the lower frequency of operation for the amplifier. For 30KHz operation and below, a 0.1uF capacitor is required. Wirebond length is critical and should be minimized.

C_{VCC}: An off chip bypass capacitor is required. Wirebond length is critical and should be minimized.

Ground Wirebonds: The SFT-0100 has backside vias and backside metal. The bottom of the die must be electrically connected to ground using eutectic or conductive epoxy die attach methods. It is not recommended to attach any wirebonds to the top GND pads.