

**DESCRIPTION**

The LX5204 is a nine-line active terminator for the SCSI parallel bus. This SCSI standard recommends active termination at both ends of the SCSI bus. The LX5204 has the added features of hot swappability, fully complying with the SCSI hot swap specification.

During disconnect mode, the LX5204 requires a meager 60 $\mu$ A of supply current while offering only 3.5pF of output capacitance. To enter this low-power mode, the disconnect pin can be left open (floating) or driven high, thereby disconnecting the terminating resistors and placing the internal low dropout regulator into low-power mode. In disconnect mode, each termination line presents a high impedance to the SCSI bus with the overall effect being to preserve high-signal integrity and yield subsequent reliable, error-free communications.

During normal operation, the LX5204 consumes only 600 $\mu$ A of current, which is the lowest enabled supply current of any terminator available on the market today. Linfinity's proprietary BiCMOS low dropout regulator architecture enables this unique and very efficient operating characteristic.

The LX5204 also offers a precisely trimmed channel output current specified to a 5% tolerance. The maximum value of the output current is trimmed as closely as possible to the SCSI standard maximum specification to give the highest possible noise margin for fast SCSI operation. And the LX5204 sinks up to 150mA of current, making it compatible with today's fast active negation drivers.

The LX5204 is a superior, pin-for-pin replacement for a variety of industry products such as the UC5603 and UC5613.

**KEY FEATURES**

- 3.5pF OUTPUT CAPACITANCE DURING DISCONNECT
- HOT SWAP COMPATIBLE
- 60 $\mu$ A SUPPLY CURRENT IN DISCONNECT MODE
- 600 $\mu$ A SUPPLY CURRENT DURING NORMAL OPERATION
- 150mA SINK CURRENT FOR ACTIVE NEGATION
- LOGIC COMMAND DISCONNECTS ALL TERMINATION LINES
- CURRENT LIMIT AND THERMAL PROTECTION
- COMPATIBLE WITH SCSI 1, 2 AND 3 STANDARDS
- CONSULT FACTORY FOR APPLICATION TEST REPORT: 5204TR

**IMPORTANT:** For the most current data, consult Linfinity's web site: <http://www.linfinity.com>.

**PRODUCT HIGHLIGHT**

RECEIVING WAVEFORM - 10MHZ

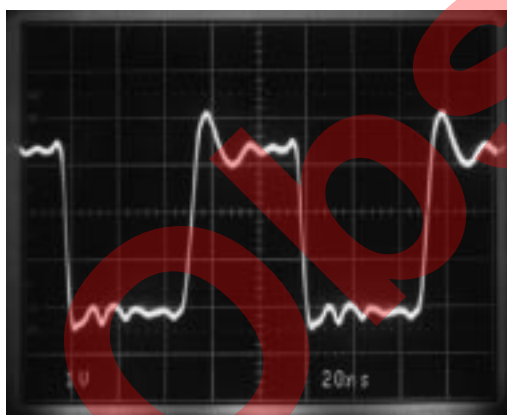

DRIVING WAVEFORM - 10MHZ

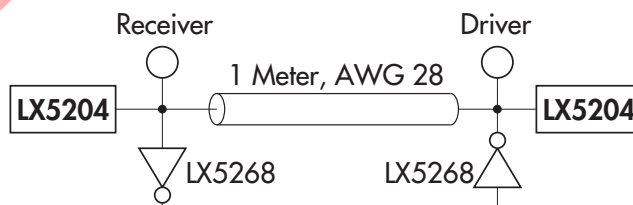
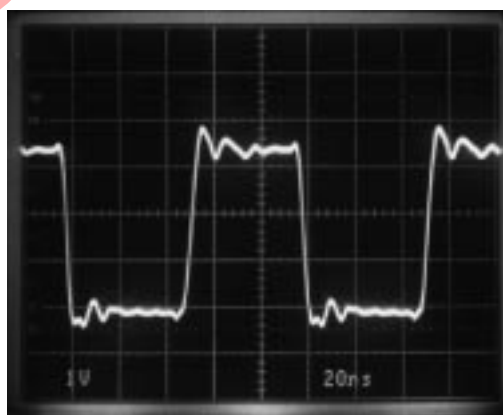

**NOTE:**  
For An In-Depth Discussion On Applying SCSI, Request Linfinity Application Note: "Understanding The Single-Ended SCSI Bus"

**PACKAGE ORDER INFORMATION**

T <sub>A</sub> (°C)	PWP	Plastic TSSOP 24-pin, Power	DP	Plastic SOIC 16-pin, Power
0 to 70		LX5204CPWP		LX5204CDP

Note: All surface-mount packages are available in Tape & Reel. Append the letter "T" to part number. (i.e. LX5204CDPT)

#### ABSOLUTE MAXIMUM RATINGS (Note 1)

TermPwr Voltage .....	+7V
Signal Line Voltage .....	0V to +7V
Regulator Output Current .....	0.4A
Operating Junction Temperature	
Plastic (PWP, DP Packages) .....	150°C
Storage Temperature Range .....	-65°C to 150°C
Lead Temperature (Soldering, 10 seconds) .....	300°C

Note 1. Exceeding these ratings could cause damage to the device. All voltages are with respect to Ground. Currents are positive into, negative out of the specified terminal.

#### THERMAL DATA

##### PWP PACKAGE:

THERMAL RESISTANCE-JUNCTION TO LEADS, $\theta_{jL}$	27°C/W
THERMAL RESISTANCE-JUNCTION TO AMBIENT, $\theta_{jA}$	60°C/W

##### DP PACKAGE:

THERMAL RESISTANCE-JUNCTION TO LEADS, $\theta_{jL}$	20°C/W
THERMAL RESISTANCE-JUNCTION TO AMBIENT, $\theta_{jA}$	45°C/W

Junction Temperature Calculation:  $T_j = T_A + (P_D \times \theta_{jA})$ .  
 The  $\theta_{jA}$  numbers are guidelines for the thermal performance of the device/pc-board system.  
 All of the above assume no ambient airflow.

#### PACKAGE PIN OUTS

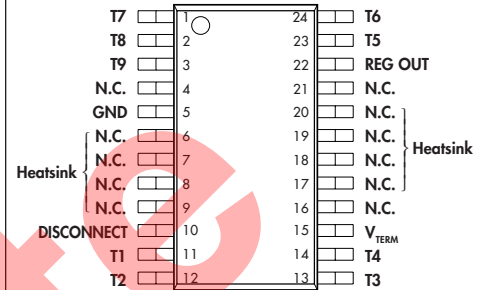

PWP PACKAGE  
(Top View)

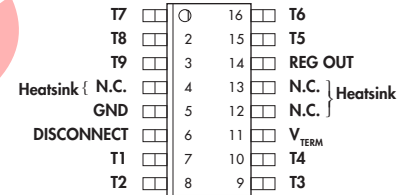

DP PACKAGE  
(Top View)

POWER UP / POWER DOWN FUNCTION TABLE

Disconnect	Outputs	Quiescent Current
L	Enabled	600 $\mu$ A
H	HI Z	60 $\mu$ A
Open	HI Z	60 $\mu$ A

9-LINE HOT SWAP,  $\mu$ POWER SCSI TERMINATOR

## PRODUCTION DATA SHEET

## RECOMMENDED OPERATING CONDITIONS (Note 2)

Parameter	Symbol	Recommended Operating Conditions			Units
		Min.	Typ.	Max.	
TermPwr Voltage	$V_{TERM}$	4		5.25	V
Signal Line Voltage		0		5	V
Disconnect Input Voltage		0		$V_{TERM}$	V
Output Capacitor on REGOUT		2.2			$\mu$ F
Operating Virtual Junction Temperature Range					
LX5204C		0		125	$^{\circ}$ C

Note 2. Range over which the device is functional.

## ELECTRICAL CHARACTERISTICS

(Unless otherwise specified, these specifications apply over the operating ambient temperature range of  $0^{\circ}\text{C} \leq T_A \leq 70^{\circ}\text{C}$ . TermPwr = 4.75V, Disconnect = 0V. Low duty cycle pulse testing techniques are used which maintains junction and case temperatures equal to the ambient temperature.)

Parameter	Symbol	Test Conditions	LX5204			Units
			Min.	Typ.	Max.	
<b>Supply Current Section</b>						
TermPwr Supply Current		All term lines = Open		0.6	1.2	mA
		All term lines = 0.5V		194	208	mA
Power Down Mode		Disconnect = Open		60	100	$\mu$ A
<b>Output Section (Terminator Lines)</b>						
Terminator Impedance		$I_{TERM} = -5\text{mA to } -15\text{mA}, T_A = 25^{\circ}\text{C}$	104	110	116	$\Omega$
		$I_{TERM} = -5\text{mA to } -15\text{mA}$	100	110	120	$\Omega$
Terminator Output High Voltage			2.7	2.9		V
Max. Output Current		$V_{OUT} = 0.5\text{V}, T_A = 25^{\circ}\text{C}$	-20.3	-21.8	-23	mA
		$V_{OUT} = 0.5\text{V}, 0^{\circ}\text{C} \leq T_A \leq 70^{\circ}\text{C}$	-19.0	-21.8	-23	mA
		$V_{OUT} = 0.5\text{V}, V_{TERM} = 4\text{V}, T_A = 25^{\circ}\text{C}$	-19.5	-21.8	-23	mA
		$V_{OUT} = 0.5\text{V}, V_{TERM} = 4\text{V}, 0^{\circ}\text{C} \leq T_A \leq 70^{\circ}\text{C}$	-18.0	-21.8	-23	mA
Output Leakage		Disconnect = Open, $V_{TERM} = 0\text{V to } 5.25\text{V}$		10	400	nA
Output Capacitance		Disconnect = Open		3.5		pF
Sink Current		$V_{OUT} = 4\text{V}$	20	30		mA
Hot Swap			Fully Compliant			
<b>Regulator Section</b>						
Regulator Output Voltage				3.6		V
Line Regulation		$V_{TERM} = 4\text{V to } 6\text{V}$		10	20	mV
Load Regulation		$I_{REG} = 0 \text{ to } -50\text{mA}$		20	50	mV
Drop Out Voltage		$I_{REG} = -50\text{mA}$		0.7	1.0	V
Short Circuit Current		$V_{REG} = 0\text{V}$		-200	-350	mA
Thermal Shutdown				150		$^{\circ}$ C
<b>Disconnect Section</b>						
Disconnect Threshold			0.8		2.0	V
Input Current		Disconnect = 0V			40	$\mu$ A

#### BLOCK DIAGRAM

FIGURE 1 — LX5204 BLOCK DIAGRAM

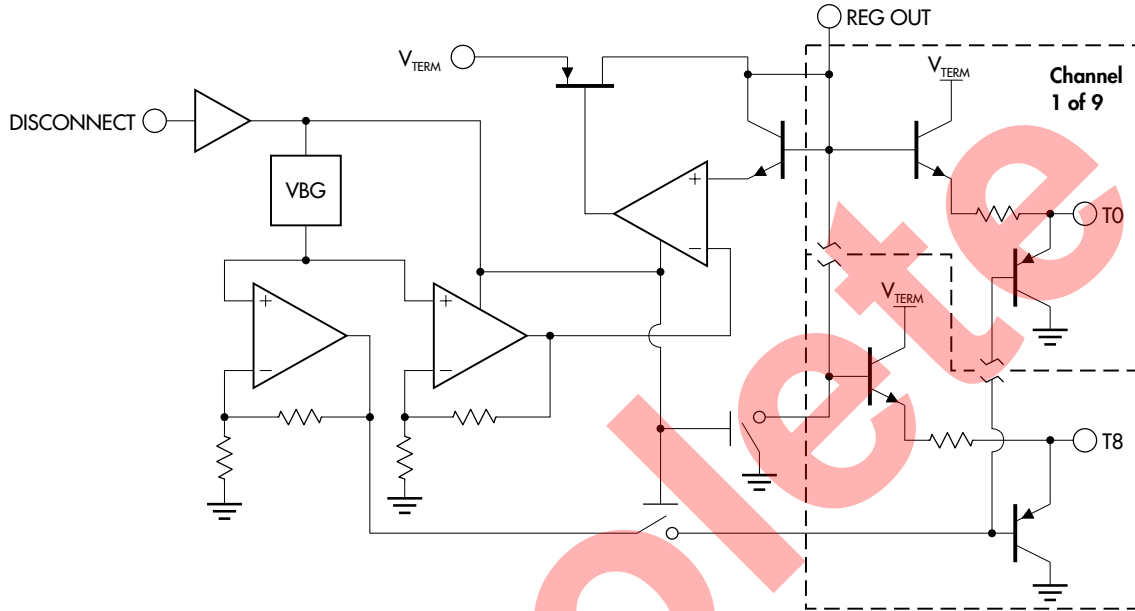

#### APPLICATION SCHEMATIC

FIGURE 2 — 8-BIT SCSI SYSTEM APPLICATION

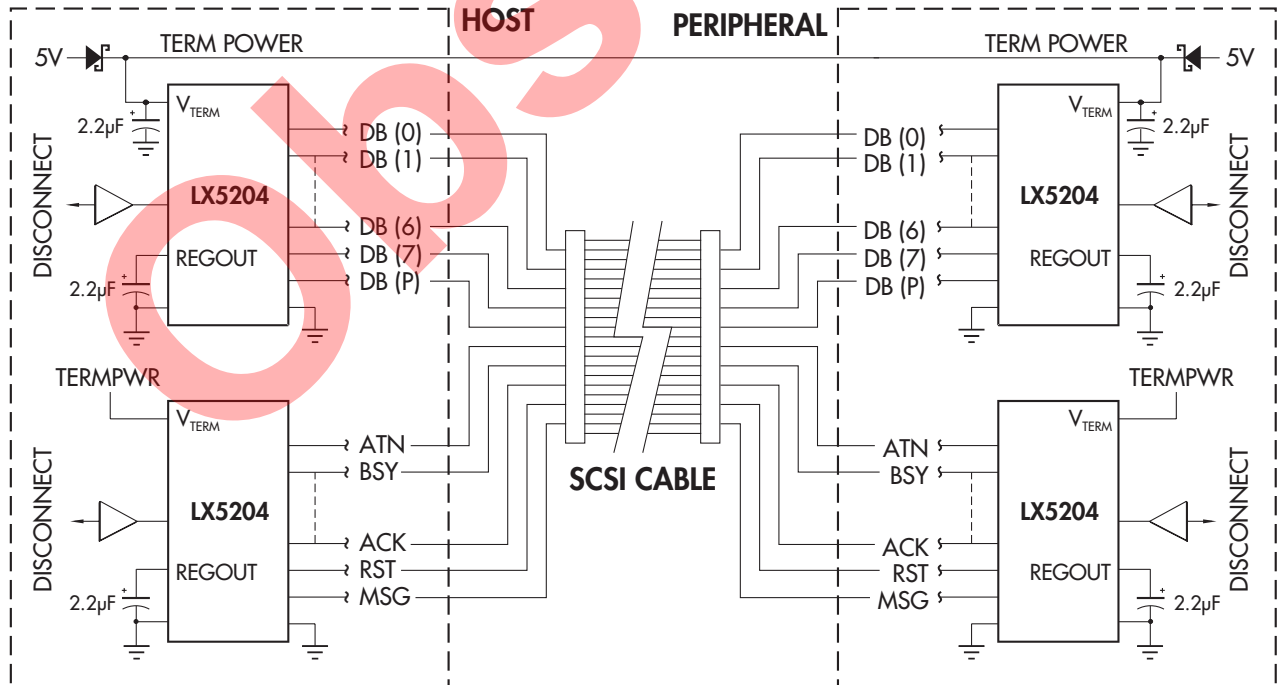

Note: Add third LX5204 for 16-bit SCSI

PRODUCTION DATA - Information contained in this document is proprietary to Linfinity, and is current as of publication date. This document may not be modified in any way without the express written consent of Linfinity. Product processing does not necessarily include testing of all parameters. Linfinity reserves the right to change the configuration and performance of the product and to discontinue product at any time.