

# 8.0-18.0 GHz Up-Converter QFN, 4x4mm

## Features

- X Integrated Balanced Mixer, LO Buffer
- X +22.0 dBm Input Third Order Intercept (IIP3)
- X +5.0 dBm LO Drive Level
- X 4x4mm QFN Package
- X 100% RF and DC Testing

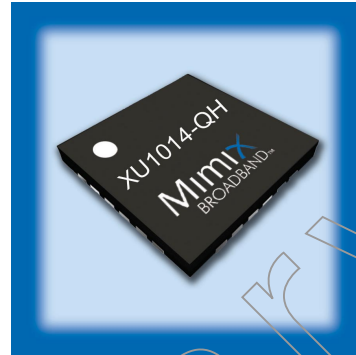

## General Description

Mimix Broadband's 8.0-18.0 GHz GaAs packaged up-converter has an input third order intercept point of +22.0 dBm and 10.0 dB of conversion loss. The device consists of a balanced resistive pHEMT mixer and LO buffer amplifier packaged in an industry standard, fully molded 4x4mm QFN package. The device includes on-chip ESD protection structures and DC by-pass capacitors to ease the implementation and volume assembly of the packaged part. This device is well suited for Millimeter-wave Point-to-Point Radio, LMDS, SATCOM and VSAT applications.

## Absolute Maximum Ratings

Parameter	Units	Min.	Max.
Drain Voltage Supply (Vdd)	V	-	4.3
Drain Current (Ids)	mA	-	85
Input Power (Pin) IF	dBm	-	5
Input Power (Pin) LO	dBm	-	10
Storage Temperature (Tstg)	°C	-55	+150
Operating Backside Temperature (Tb)	°C	-45	+85
ESD-Machine Model (ESD_MM)	Class A		
ESD-Human Body Model (ESD_HBM)	Class 0		
MSL Level (MSL)	MSL3		

## Electrical Characteristics (Ambient Temperature T = 25 °C)

Parameter	Units	Min.	Typ.	Max.
Frequency Range (RF/LO)	GHz	8		18
Frequency Range (IF)	GHz	DC		3.5
Conversion Loss (CL)	dB		10	
Input Third Order Intercept (IIP3)	dBm		22	
LO Input Drive	dBm		5	
LO Leakage at RF	dBm		-25	
RF Input Return Loss	dB		15	
LO Input Return Loss	dB		15	
IF Input Return Loss	dB		15	
Drain Bias Voltage (Vd)	VDC		4	4
Gate Bias Voltage (Vg1)	VDC		-0.3	
Gate Bias Voltage (Vg2)	VDC		-3	
Supply Current (Id1)	mA		80	

# 8.0-18.0 GHz Up-Converter QFN, 4x4mm

August 2009 - Rev 31-Aug-09

## Up-Converter Measurements

XU1014-QH: Conversion Gain vs RF Frequency IF=2GHz, Vd1=4V, Id1=65mA, Vg2=-2V, PLO=5dBm

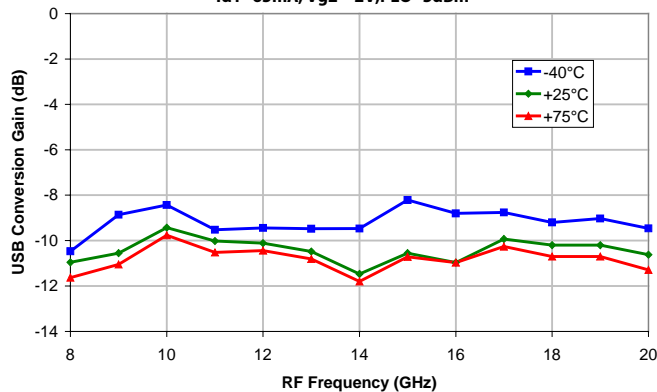

XU1014-QH: Conversion Gain vs RF Frequency IF=2GHz Vd1=4V, Id1=65mA, Vg2=-2V, PLO=5dBm

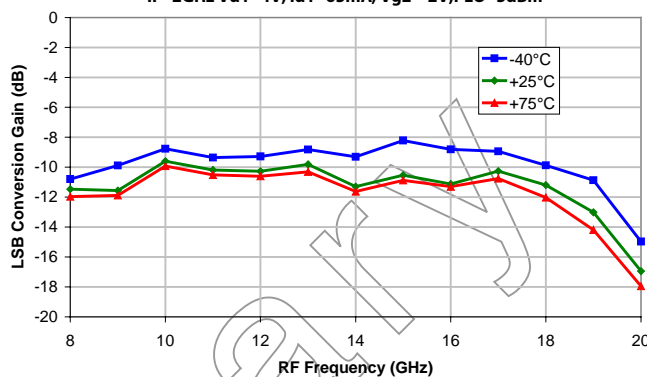

XU1014-QH: IIP3 vs RF Frequency IF=2GHz, Vd1=4V, Id1=65mA, Vg2=-2V, PLO=5dBm

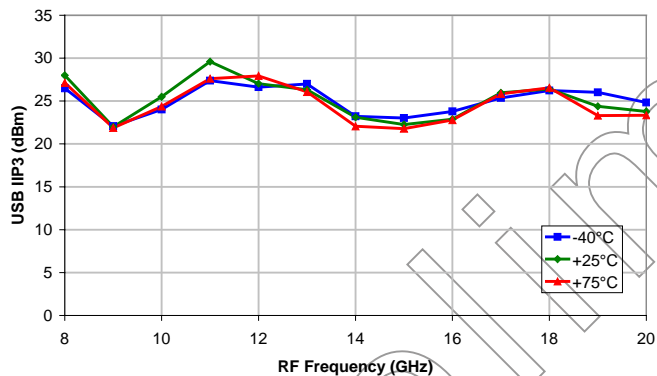

XU1014-QH: IIP3 vs RF Frequency IF=2GHz, Vd1=4V, Id1=65mA, Vg2=-2V, PLO=5dBm

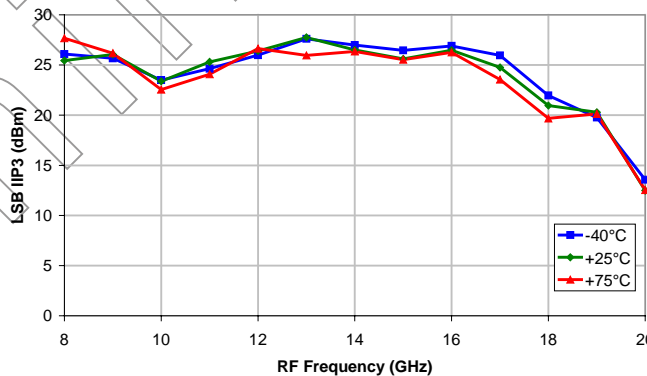

XU1014-QH: LO Leakage at RF vs LO Frequency Vd1=4V, Id1=65mA, Vg2=-2V, PLO=5dBm

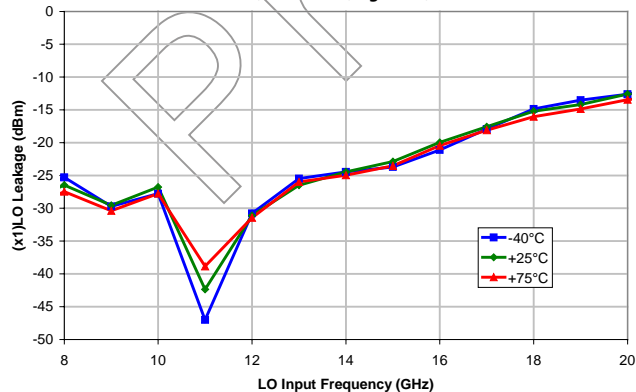

XU1014-QH: (x2) LO Leakage vs LO Frequency Vd1=4V, Id1=65mA, Vg2=-2V, PLO=5dBm

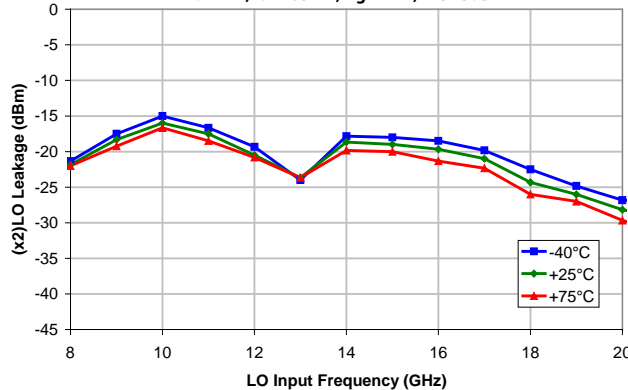

# 8.0-18.0 GHz Up-Converter QFN, 4x4mm

August 2009 - Rev 31-Aug-09

## Up-Converter Measurements (cont.)

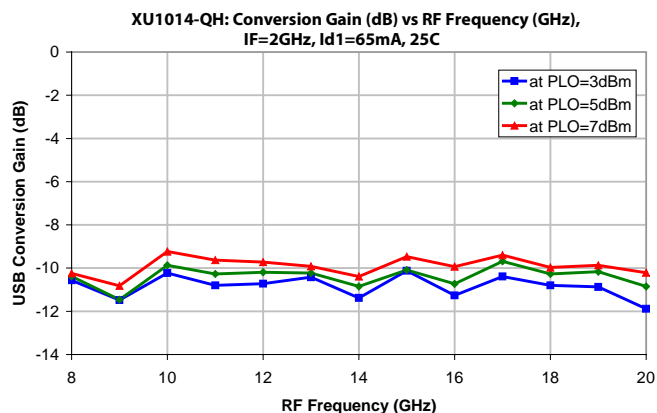
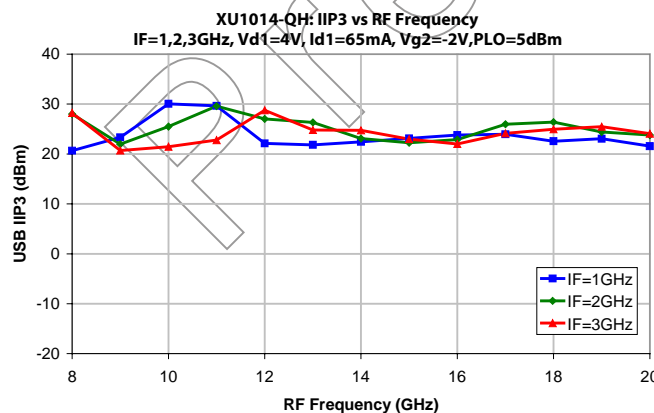
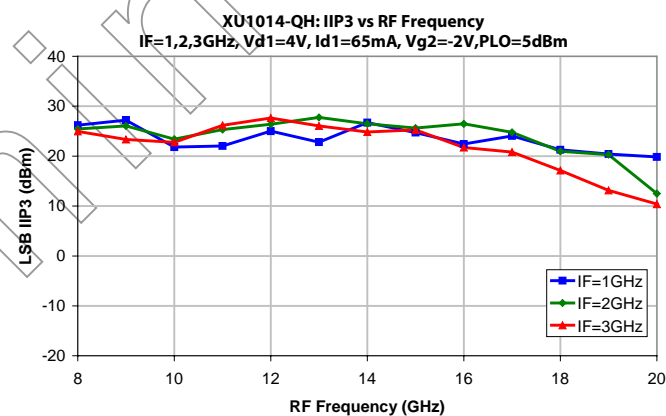
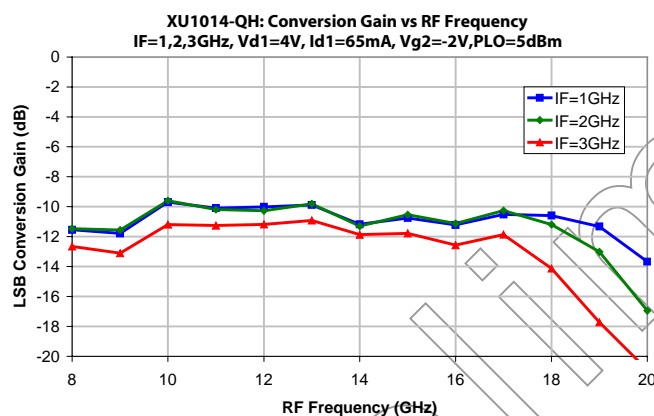
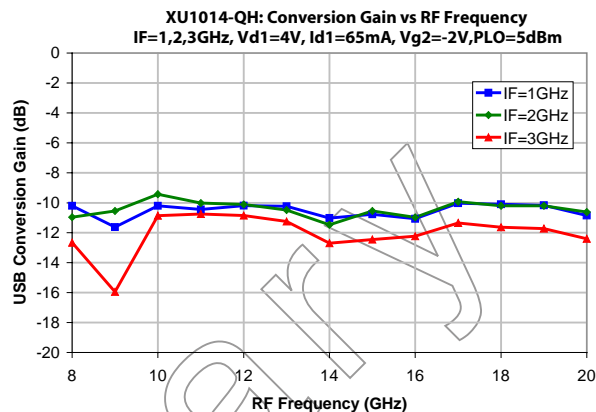
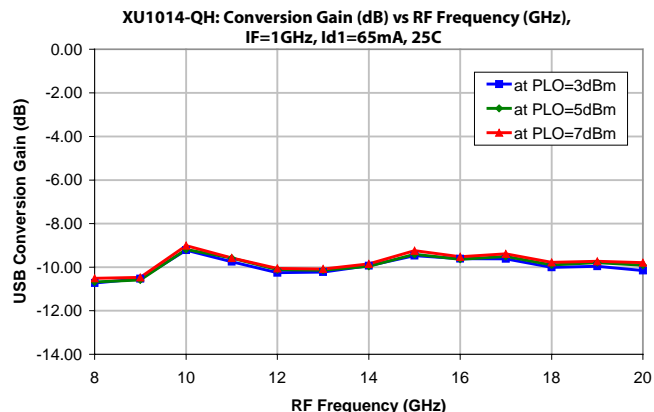

# 8.0-18.0 GHz Up-Converter QFN, 4x4mm

## Up-Converter Measurements (cont.)

XUI014-QH: IIP3 (dBm) vs RF Frequency (GHz), IF=2GHz,  
Id1=65mA, 25C

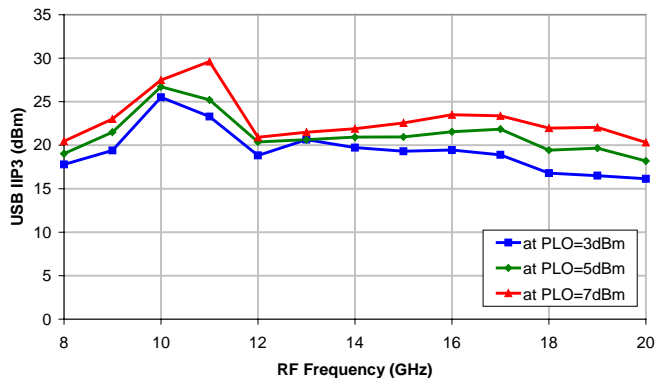

XUI014-QH: P1dB (dBm) vs RF Frequency (GHz), IF=2GHz,  
Id1=65mA, 25C

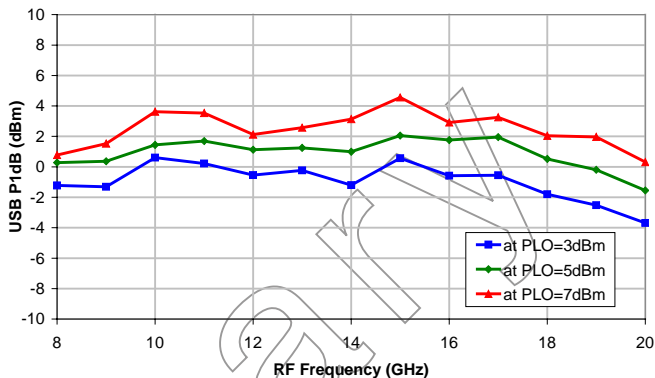

Preliminary

# 8.0-18.0 GHz Up-Converter QFN, 4x4mm

August 2009 - Rev 31-Aug-09

## Package Dimensions / Layout

Pin 1 Dot  
By marking

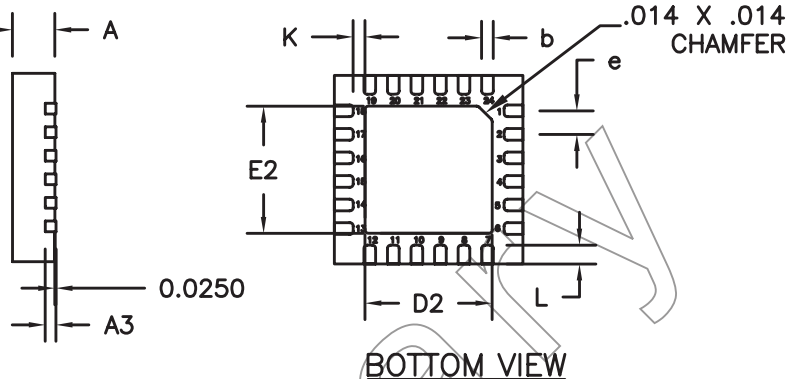
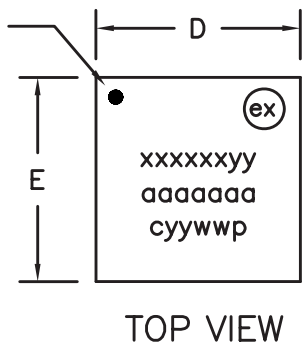

RECOMMENDED SOLDER PAD PITCH AND DIMENSIONS Note:

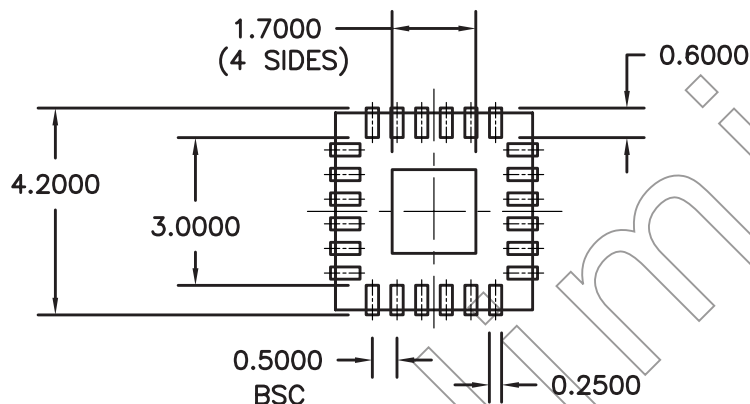

1. ALL DIMENSIONS ARE IN mm.

	MIN	TYP	MAX
A	0.80	0.90	1.00
A3	0.20 REF		
b	0.20	0.25	0.30
K	0.20	-	-
D	4.00 BSC		
E	4.00 BSC		
e	0.50		
D2	2.45	2.60	2.75
E2	2.45	2.60	2.75
L	0.20	0.30	0.40

## Functional Schematic

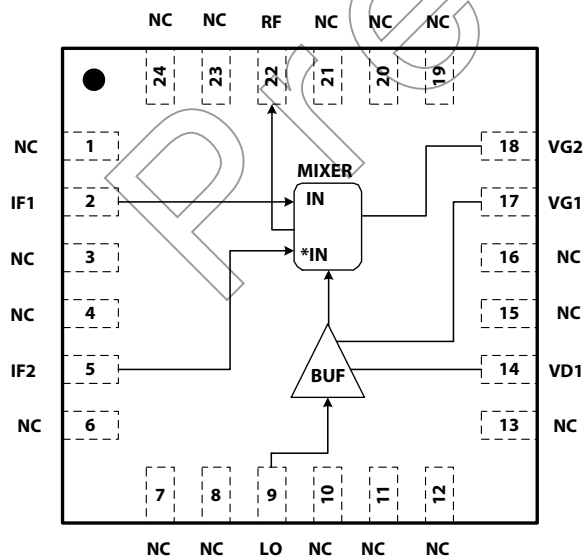

## Pin Designations

Pin Number	Pin Name	Pin Function	Nominal Value
1	NC	Not Connected	
2	IF1	IF1 Input	
3-4	NC	Not Connected	
5	IF2	IF2 Input	
6-8	NC	Not Connected	
9	LO	LO Input	
10-13	NC	Not Connected	
14	VD1	Drain 1 Bias	4V, 80 mA
15-16	NC	Not Connected	
17	VG1	Gate 1 Bias	-0.3V
18	VG2	Gate 2 Bias	2V
19-21	NC	Not Connected	
22	RF	RF Output	
23-24	NC	Not Connected	

# 8.0-18.0 GHz Up-Converter QFN, 4x4mm

August 2009 - Rev 31-Aug-09

**App Note [1] Biasing** - As shown in the Pin Designations table, the device is operated under the nominal bias conditions of VD1 at 7.0V with 80mA respectively. It is recommended to use active bias to keep the currents constant in order to maintain the best performance over temperature. Depending on the supply voltage available and the power dissipation constraints, the bias circuit may be a single transistor or a low power operational amplifier, with a low value resistor in series with the drain supply used to sense the current. The gate of the pHEMT is controlled to maintain correct drain current and thus drain voltage. The typical gate voltage needed to do this is -1.0V. Make sure to sequence the applied voltage to ensure negative gate bias is available before applying the positive drain supply.

**App Note [2] Board Layout** - As shown in the board layout, it is recommended to provide 100pF decoupling caps as close to the bias pins as possible, with additional 10μF decoupling caps.

## Recommended Layout

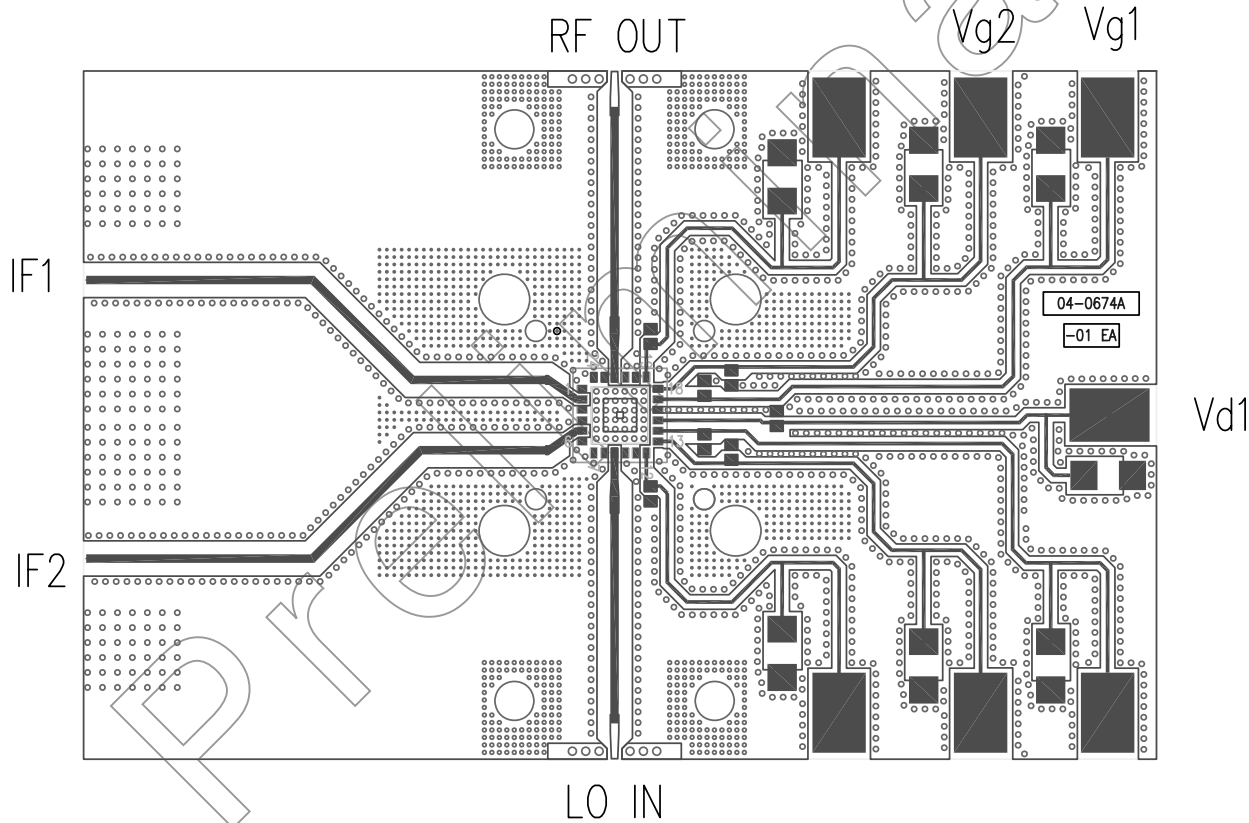

# 8.0-18.0 GHz Up-Converter QFN, 4x4mm

August 2009 - Rev 31-Aug-09

## Handling and Assembly Information

**CAUTION!** - Mimix Broadband MMIC Products contain gallium arsenide (GaAs) which can be hazardous to the human body and the environment. For safety, observe the following procedures:

- Do not ingest.
- Do not alter the form of this product into a gas, powder, or liquid through burning, crushing, or chemical processing as these by-products are dangerous to the human body if inhaled, ingested, or swallowed.
- Observe government laws and company regulations when discarding this product. This product must be discarded in accordance with methods specified by applicable hazardous waste procedures.

### Electrostatic Sensitive Device -

Observe all necessary precautions when handling.

**Life Support Policy** - Mimix Broadband's products are not authorized for use as critical components in life support devices or systems without the express written approval of the President and General Counsel of Mimix Broadband. As used herein: (1) Life support devices or systems are devices or systems which, (a) are intended for surgical implant into the body, or (b) support or sustain life, and whose failure to perform when properly used in accordance with instructions for use provided in the labeling, can be reasonably expected to result in a significant injury to the user. (2) A critical component is any component of a life support device or system whose failure to perform can be reasonably expected to cause the failure of the life support device or system, or to affect its safety or effectiveness.

**Package Attachment** - This packaged product from Mimix Broadband is provided as a rugged surface mount package compatible with high volume solder installation. Vacuum tools or other suitable pick and place equipment may be used to pick and place this part. Care should be taken to ensure that there are no voids or gaps in the solder connection so that good RF, DC and ground connections are maintained. Voids or gaps can eventually lead not only to RF performance degradation, but reduced reliability and life of the product due to thermal stress.

### Typical Reflow Profiles

Reflow Profile	SnPb	Pb Free
Ramp Up Rate	3-4 °C/sec	3-4 °C/sec
Activation Time and Temperature	60-120 sec @ 140-160 °C	60-180 sec @ 170-200 °C
Time Above Melting Point	60-150 sec	60-150 sec
Max Peak Temperature	240 °C	265 °C
Time Within 5 °C of Peak	10-20 sec	10-20 sec
Ramp Down Rate	4-6 °C/sec	4-6 °C/sec

**Mimix Lead-Free RoHS Compliant Program** - Mimix has an active program in place to meet customer and governmental requirements for eliminating lead (Pb) and other environmentally hazardous materials from our products. All Mimix RoHS compliant components are form, fit and functional replacements for their non-RoHS equivalents. Lead plating of our RoHS compliant parts is 100% matte tin (Sn) over copper alloy and is backwards compatible with current standard SnPb low-temperature reflow processes as well as higher temperature (260°C reflow) "Pb Free" processes.

## Ordering Information

### Part Number for Ordering

XU1014-QH-0G00  
XU1014-QH-0G0T  
XU1014-QH-EV1

### Description

Matte Tin plated RoHS compliant 4x4 24L QFN surface mount package in bulk quantity  
Matte Tin plated RoHS compliant 4x4 24L QFN surface mount package in tape and reel  
XU1014-QH evaluation board



Proper ESD procedures should be followed when handling this device.

Mimix Broadband, Inc., 10795 Rockley Rd., Houston, Texas 77099  
Tel: 281.988.4600 Fax: 281.988.4615 mimixbroadband.com

Page 7 of 7