



SST™ SERIES SU/G

VHF/UHF SILICON POWER FETS
10 TO 120 WATTS, 10MHz-500MHz

MICROWAVE TECHNOLOGY 4268 Solar Way Fremont, CA 94538 415-651-6700 FAX 415-651-2208

T-39-01

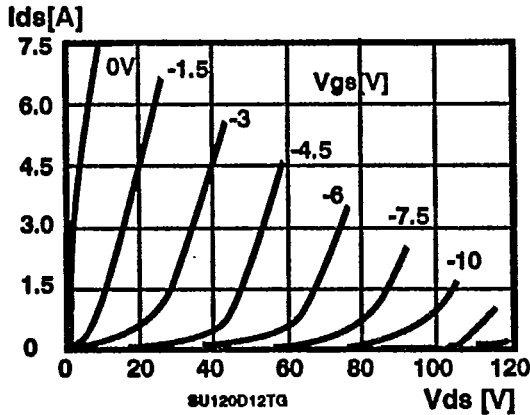

FEATURES

- N-CHANNEL JFET, DEPLETION MODE
- APPLICATION RANGE 10 MHz TO 500 MHz
- POWER OUTPUTS FROM 10 TO 120 WATTS CW
- CLASS A, B, OR C OPERATION
- HIGH POWER EFFICIENCY
- NO THERMAL RUNAWAY
- NO dV/dT LATCH-UP OR SECONDARY BREAKDOWN
- BROADBAND CAPABILITY
- COMMON GATE CONFIGURATION
- CHOICE OF PACKAGES

DESCRIPTION

The SST Series SU silicon power FETs are designed for power amplifier applications where power efficiency, linearity, broadband performance, and ruggedness are top priorities. The structure of the SST can be called a Solid State Triode™ since it has a non-saturating I-V curve. The higher input impedance of these devices simplifies the design of multi-device matched power modules. Drain supply voltages of 28 to 65 volts insure lower currents than in other comparable FET structures producing higher power levels and efficiencies. Finally, the device is very rugged and can withstand high VSWR levels without damage and operate over very large temperature ranges (Tj) from -200 to 200°C).

ELECTRICAL SPECIFICATIONS – COMMON GATE CONFIGURATION*

DEVICE	Output Power [W] min	D/S Blocking Volt. [V] min	Power Gain [dB] typ ¹	Power Efficiency [%] min	MAXIMUM RATINGS		PKG
					Drain Current Ids [A]	Power Dissipation Pd [W]	
SU10A12TG	10	120	10	55	0.8	25	A
SU25A12TG	25	120	10	55	2.0	50	A
SU25B12TG	25	120	10	55	2.0	75	B
SU50B12TG	50	120	10	55	4.0	90	B
SU50D12TG	50	120	10	55	4.0	90	D
SU50C12TG	50	120	10	55	2.0	90	C
SU75B12TG	75	120	10	50	6.0	125	B
SU80C12TG	80	120	10	55	4.0	90	C
SU80D12TG	80	120	10	50	6.0	150	D
SU120D12TG	120	120	10	50	8.0	200	D

* Contact MwT for individual data sheets, additional specifications and test conditions.

¹ - f=500 MHz, Vgs=50 Volts



**EQUIVALENT
CIRCUIT**

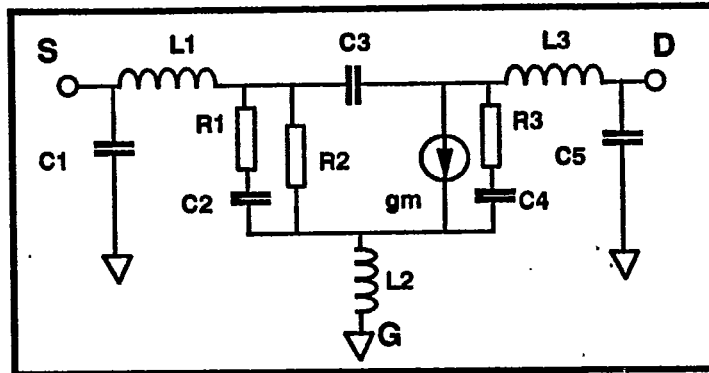

DEVICE	C1 [pf]	C2 [pf]	C3 [pf]	C4 [pf]	C5 [pf]	gm [mS]	L1 [nH]	L2 [nH]	L3 [nH]	R1 [Ω]	R2 [Ω]	R3 [Ω]
SU10A12TG	1.1	4	0.5	4	0.8	70	1.9	0.2	1.1	9	20	9
SU25A12TG	1.1	10	1.1	10	1.1	160	1.0	0.2	0.7	4	12	4
SU25B12TG	1.1	10	1.1	10	1.1	160	1.0	0.3	0.7	4	12	4
SU50B12TG	1.5	23	2.1	18	1.5	240	0.7	0.5	0.7	2	7	2
SU50D12TG	1.5	23	2.1	18	1.5	240	0.4	0.1	0.4	2	7	2
SU50C12TG	1.5	15	2.0	18	1.5	450	0.4	0.2	0.4	4	6	4
SU75B12TG	1.5	30	3.5	25	1.5	340	0.4	0.5	0.4	2	5	2
SU80C12TG	1.0	32	3.5	24	1.0	220	0.7	0.2	0.7	2	7	2
SU80D12TG	1.5	28	3.0	23	1.5	340	0.3	0.1	0.3	2	5	2
SU120D12TG	2.0	42	5.0	37	2.0	440	0.2	0.1	0.2	1	4	1

PACKAGE DRAWINGS

