

SPECIFICATION FOR APPROVAL

Customer : _____
Product Type : MOSFET
TXC PN : MA8014D10000000
Version : A1
Customer PN : _____

TXC Sales / Rep. : Rich Cheng
Date of Issue : 2011-11-20

Customer Signature : _____

- (1) TXC requires on copy returned with signature and title of authorized individual that signifies acceptance of the attached specifications.
- (2) Orders received and accepted by TXC after return of signed copy of specification will be produced per these specifications
- (3) Any changes to these specification must be agreed upon by both parties and new version of the Product Specification Sheet will be issued.
- (4) Any issuance of purchase order prior to consigning back the Approval page of "Specification Sheets" from customers will be regarded as the agreements o the contents of these specifications.

RoHS Compliant

PRODUCT SPECIFICATION SHEET

Product Type : MOSFET
Product Description : N-Ch 80V TO-252
TXC PN : MA8014D10000000
Version : A1

| PE / RD | QA | MFG |
|-------------------|------------------|--------------------|
| <i>Simon Wang</i> | <i>Jon Hsieh</i> | <i>Shu-Chen ko</i> |
| 2011/11/19 | 2011/11/19 | 2011/11/19 |

Note :

- (1) Lead Free Pproducts are "Directive 2002/95/EC of The European Parliament of 27 January 2003 on the restriction of the use of certain hazardous substance (RoHS) in the electrical and electronic equipment" Complaint (Attachment : SGS Test Report)
- (2) Revision "Sx" is for engineering sample only. PE/RD's approval required.
- (3) Revision "Ax" is production ready. PE/RD, QA and MFG's approval required.

RoHS Compliant

General Description

The MA8014D is the highest performance trench N-ch MOSFETs with extreme high cell density, which provide excellent R_{DS(on)} and gate charge for most of the synchronous buck converter applications.

The MA8014D meet the RoHS and Green Product requirement, 100% EAS guaranteed with full function reliability approved.

Features

- Advanced high cell density Trench technology
- Super Low Gate Charge
- Excellent CdV/dt effect decline
- 100% EAS Guaranteed
- Green Device Available

Absolute Maximum Ratings

| Symbol | Parameter | Rating | Units |
|-------------------------------------|--|------------|-------|
| V _{DS} | Drain-Source Voltage | 80 | V |
| V _{GS} | Gate-Source Voltage | ± 20 | V |
| I _D @T _C =25 | Continuous Drain Current, V _{GS} @ 10V ¹ | 11.8 | A |
| I _D @T _C =100 | Continuous Drain Current, V _{GS} @ 10V ¹ | 7.5 | A |
| I _D @T _A =25 | Continuous Drain Current, V _{GS} @ 10V ¹ | 3 | A |
| I _D @T _A =70 | Continuous Drain Current, V _{GS} @ 10V ¹ | 2.4 | A |
| I _{DM} | Pulsed Drain Current ² | 25 | A |
| EAS | Single Pulse Avalanche Energy ³ | 20.5 | mJ |
| I _{AS} | Avalanche Current | 17.6 | A |
| P _D @T _C =25 | Total Power Dissipation ⁴ | 31.3 | W |
| P _D @T _A =25 | Total Power Dissipation ⁴ | 2.02 | W |
| T _{STG} | Storage Temperature Range | -55 to 150 | |
| T _J | Operating Junction Temperature Range | -55 to 150 | |

Thermal Data

| Symbol | Parameter | Typ. | Max. | Unit |
|------------------|--|------|------|------|
| R _{θJA} | Thermal Resistance Junction-Ambient ¹ | --- | 62 | /W |
| R _{θJC} | Thermal Resistance Junction-Case ¹ | --- | 4 | /W |

Product Summary



| BVDSS | R _{DS(on)} | I _D |
|-------|---------------------|----------------|
| 80V | 100mΩ | 11.8A |

Applications

- High Frequency Point-of-Load Synchronous Buck Converter
- Networking DC-DC Power System
- Power Tool Application

TO252 Pin Configuration

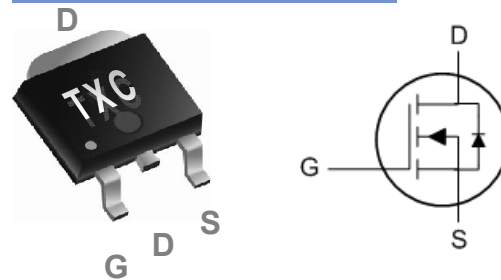

Electrical Characteristics ($T_J=25$, unless otherwise noted)

| Symbol | Parameter | Conditions | Min. | Typ. | Max. | Unit |
|----------------|--|--|------|-------|-----------|------------|
| BV_{DSS} | Drain-Source Breakdown Voltage | $V_{GS}=0V, I_D=250\mu A$ | 80 | --- | --- | V |
| BV_{DSS}/T_J | BV_{DSS} Temperature Coefficient | Reference to 25 , $I_D=1mA$ | --- | 0.072 | --- | V/ |
| $R_{DS(ON)}$ | Static Drain-Source On-Resistance ² | $V_{GS}=10V, I_D=10A$ | --- | 80 | 100 | m Ω |
| | | $V_{GS}=4.5V, I_D=8A$ | --- | 90 | 115 | m Ω |
| $V_{GS(th)}$ | Gate Threshold Voltage | $V_{GS}=V_{DS}, I_D=250\mu A$ | 1.2 | --- | 2.5 | V |
| $V_{GS(th)}$ | $V_{GS(th)}$ Temperature Coefficient | | --- | -4.7 | --- | mV/ |
| I_{DSS} | Drain-Source Leakage Current | $V_{DS}=64V, V_{GS}=0V, T_J=25$ | --- | --- | 1 | μA |
| | | $V_{DS}=64V, V_{GS}=0V, T_J=55$ | --- | --- | 5 | |
| I_{GSS} | Gate-Source Leakage Current | $V_{GS}=\pm 20V, V_{DS}=0V$ | --- | --- | ± 100 | nA |
| gfs | Forward Transconductance | $V_{DS}=5V, I_D=10A$ | --- | 14.7 | --- | S |
| R_g | Gate Resistance | $V_{DS}=0V, V_{GS}=0V, f=1MHz$ | --- | 2.8 | 5.6 | Ω |
| Q_g | Total Gate Charge (10V) | $V_{DS}=64V, V_{GS}=10V, I_D=10A$ | --- | 18.6 | 26 | nC |
| Q_{gs} | Gate-Source Charge | | --- | 3.9 | 5.5 | |
| Q_{gd} | Gate-Drain Charge | | --- | 3.2 | 4.5 | |
| $T_{d(on)}$ | Turn-On Delay Time | $V_{DD}=40V, V_{GS}=10V, R_G=3.3\Omega, I_D=10A$ | --- | 5 | 10 | ns |
| T_r | Rise Time | | --- | 25 | 45 | |
| $T_{d(off)}$ | Turn-Off Delay Time | | --- | 21 | 42 | |
| T_f | Fall Time | | --- | 7.6 | 15.2 | |
| C_{iss} | Input Capacitance | $V_{DS}=15V, V_{GS}=0V, f=1MHz$ | --- | 1090 | 1526 | pF |
| C_{oss} | Output Capacitance | | --- | 60 | 84 | |
| C_{rss} | Reverse Transfer Capacitance | | --- | 41 | 57 | |

Guaranteed Avalanche Characteristics

| Symbol | Parameter | Conditions | Min. | Typ. | Max. | Unit |
|--------|--|-----------------------------------|------|------|------|------|
| EAS | Single Pulse Avalanche Energy ⁵ | $V_{DD}=50V, L=0.1mH, I_{AS}=12A$ | 9.5 | --- | --- | mJ |

Diode Characteristics

| Symbol | Parameter | Conditions | Min. | Typ. | Max. | Unit |
|----------|--|-------------------------------------|------|------|------|------|
| I_S | Continuous Source Current ^{1,6} | $V_G=V_D=0V, \text{Force Current}$ | --- | --- | 11.8 | A |
| I_{SM} | Pulsed Source Current ^{2,6} | | --- | --- | 25 | A |
| V_{SD} | Diode Forward Voltage ² | $V_{GS}=0V, I_S=A, T_J=25$ | --- | --- | 1.2 | V |
| t_{rr} | Reverse Recovery Time | $I_F=10A, dI/dt=100A/\mu s, T_J=25$ | --- | 18.6 | --- | nS |
| Q_{rr} | Reverse Recovery Charge | | --- | 17.7 | --- | nC |

Note :

- The data tested by surface mounted on a 1 inch²FR-4 board with 2OZ copper.
- The data tested by pulsed , pulse width $\leq 300\mu s$, duty cycle $\leq 2\%$
- The EAS data shows Max. rating . The test condition is $V_{DD}=50V, V_{GS}=10V, L=0.1mH, I_{AS}=17.6A$
- The power dissipation is limited by 150 junction temperature
- The Min. value is 100% EAS tested guarantee.
- The data is theoretically the same as I_D and I_{DM} , in real applications , should be limited by total power dissipation.

Typical Characteristics

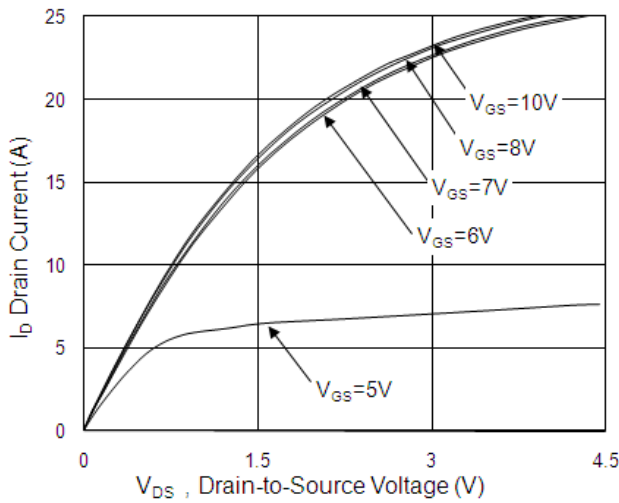

Fig.1 Typical Output Characteristics

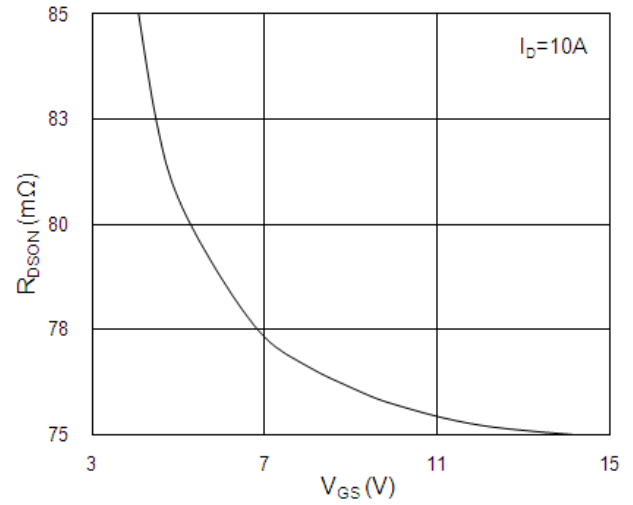

Fig.2 On-Resistance v.s Gate-Source

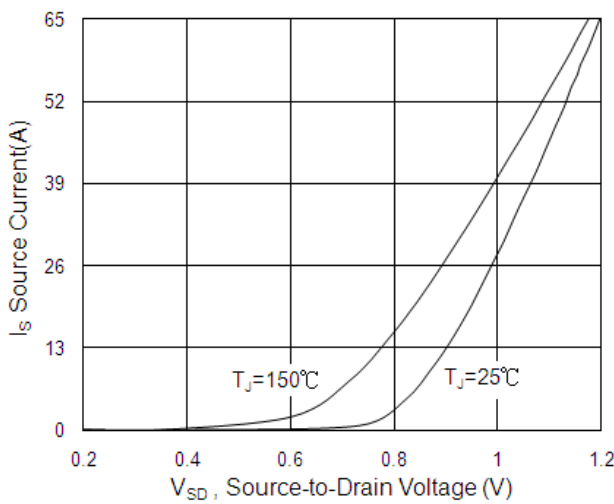

Fig.3 Forward Characteristics of Reverse

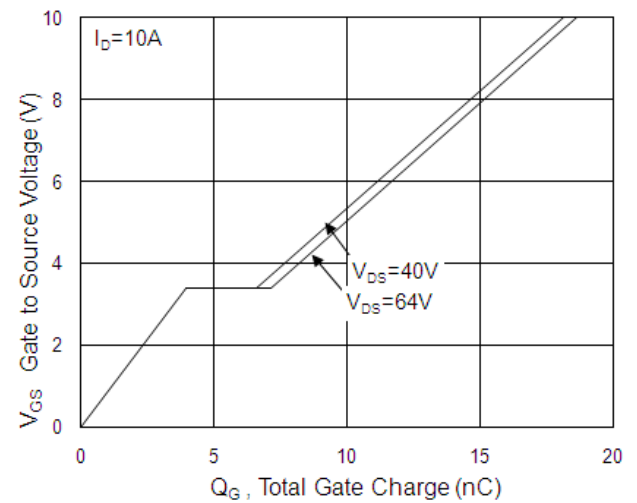

Fig.4 Gate-Charge Characteristics

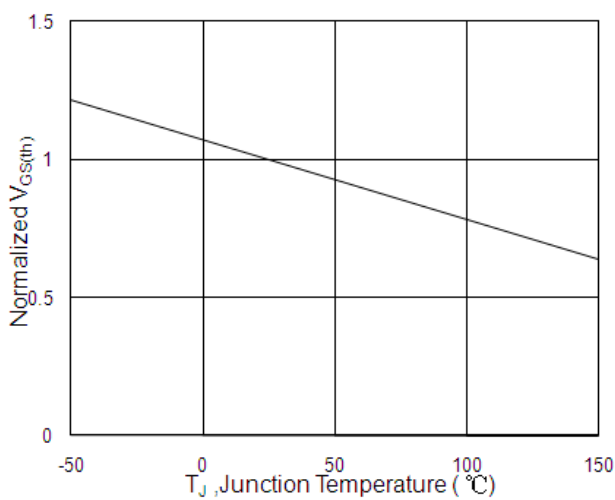

Fig.5 Normalized $V_{GS(th)}$ vs. T_J

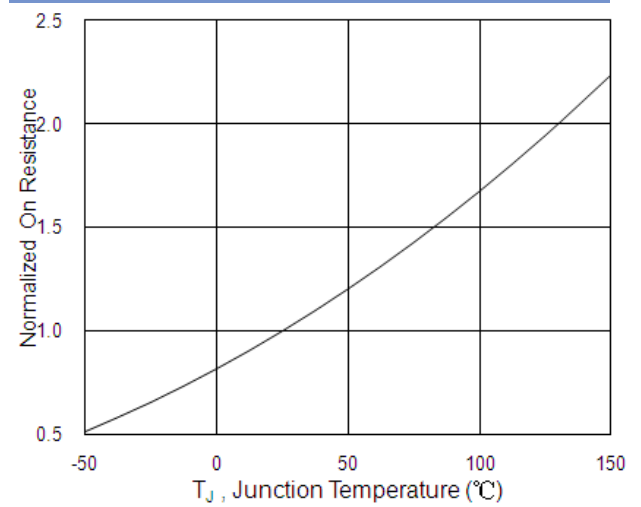

Fig.6 Normalized $R_{DS(on)}$ vs. T_J

N-Ch 80V Fast Switching MOSFETs

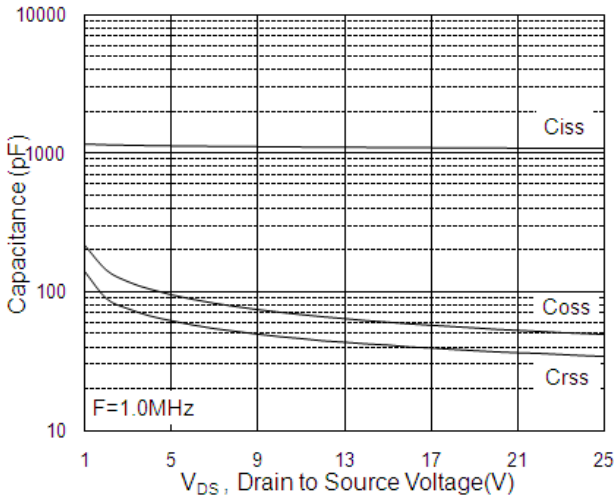

Fig.7 Capacitance

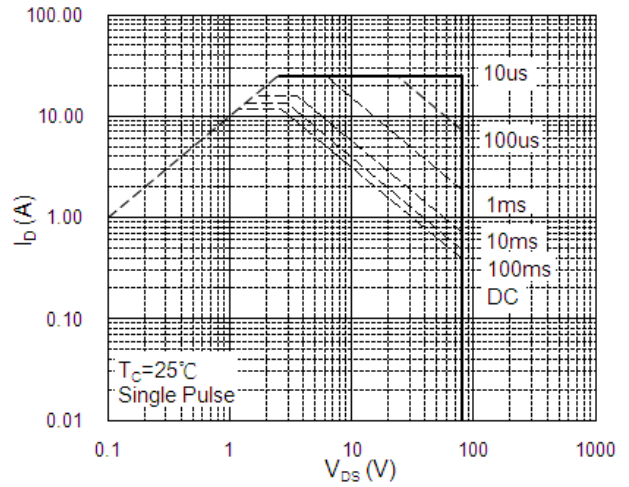

Fig.8 Safe Operating Area

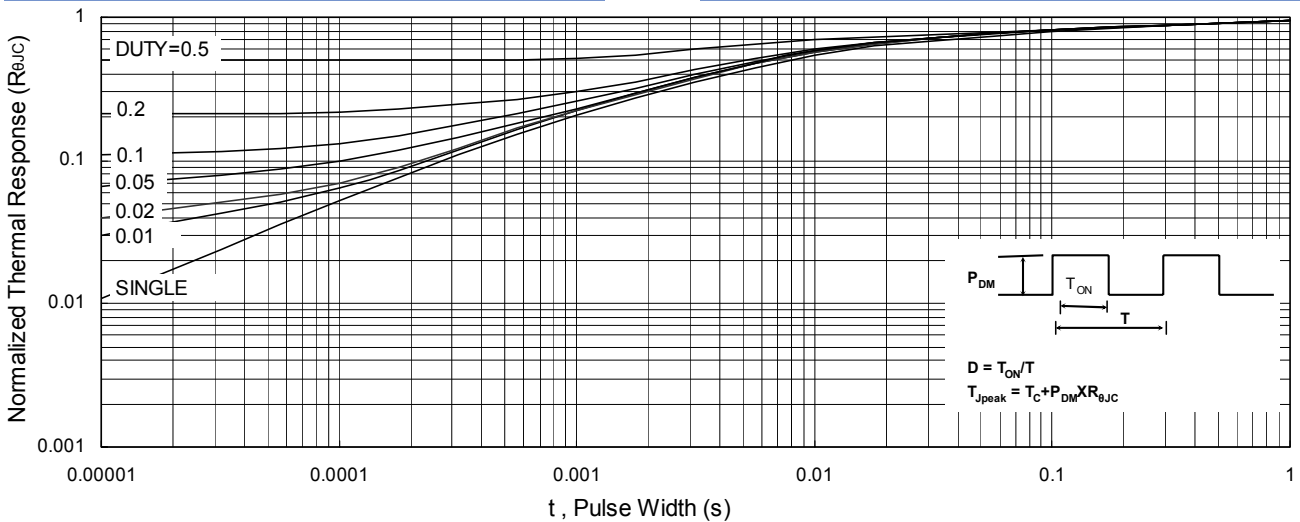

Fig.9 Normalized Maximum Transient Thermal Impedance

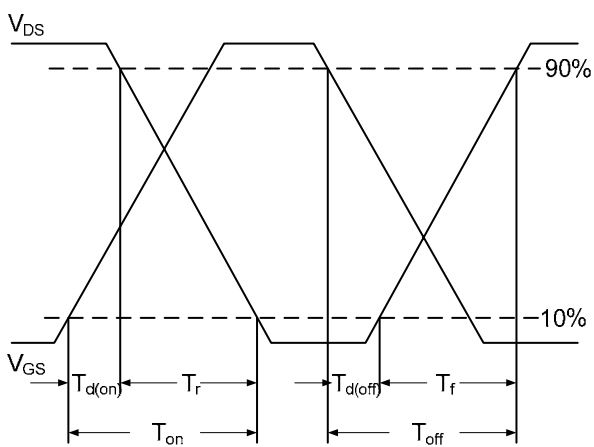

Fig.10 Switching Time Waveform

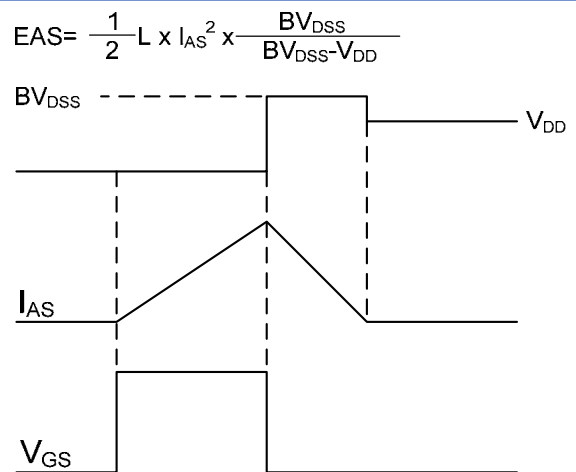
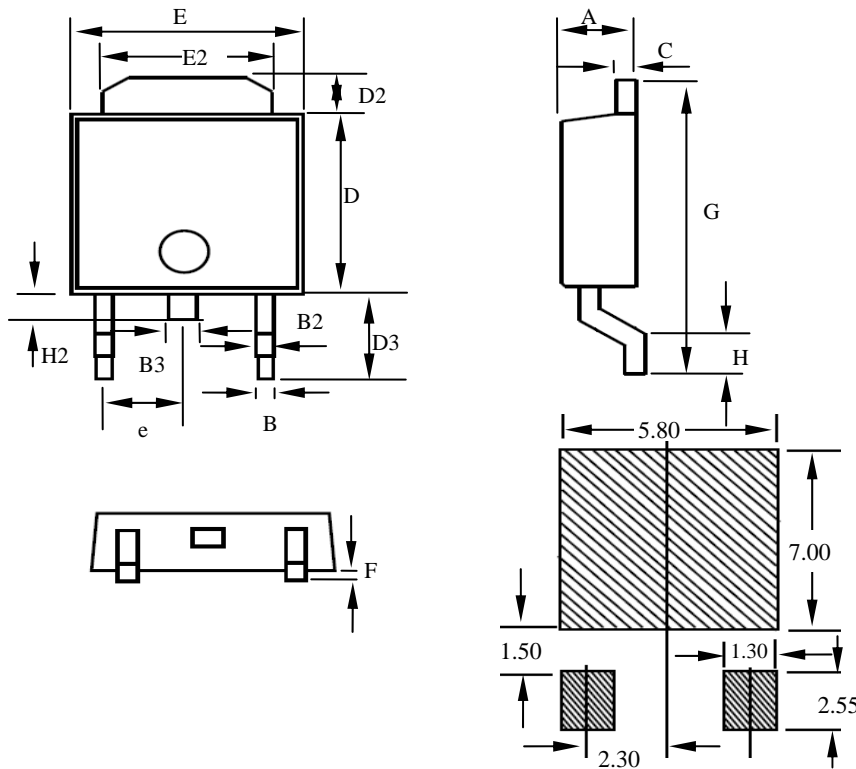

Fig.11 Unclamped Inductive Switching Waveform



LAND PATTERN RECOMMENDATION

| SYMBOLS | MILLIMETERS | | | INCHES | | |
|---------|-------------|-----|-------|--------|-----|-------|
| | MIN | NOM | MAX | MIN | NOM | MAX |
| A | 2.10 | -- | 2.50 | 0.083 | -- | 0.098 |
| B | 0.30 | -- | 0.89 | 0.012 | -- | 0.035 |
| B2 | 0.40 | -- | 1.14 | 0.016 | -- | 0.045 |
| B3 | 0.60 | -- | 1.00 | 0.024 | -- | 0.039 |
| C | 0.40 | -- | 0.89 | 0.016 | -- | 0.035 |
| D | 5.30 | -- | 6.25 | 0.209 | -- | 0.246 |
| D2 | 0.50 | -- | 1.70 | 0.020 | -- | 0.067 |
| D3 | 2.20 | -- | 3.40 | 0.087 | -- | 0.134 |
| E | 6.30 | -- | 6.80 | 0.248 | -- | 0.268 |
| E2 | 4.80 | -- | 5.50 | 0.189 | -- | 0.217 |
| F | 0.00 | -- | 0.30 | 0.000 | -- | 0.012 |
| G | 9.20 | -- | 10.41 | 0.362 | -- | 0.410 |
| H | 0.90 | -- | 1.95 | 0.035 | -- | 0.077 |
| H2 | 0.50 | -- | 1.20 | 0.020 | -- | 0.047 |
| e | 2.30 | -- | 2.40 | 0.091 | -- | 0.094 |

MARKING

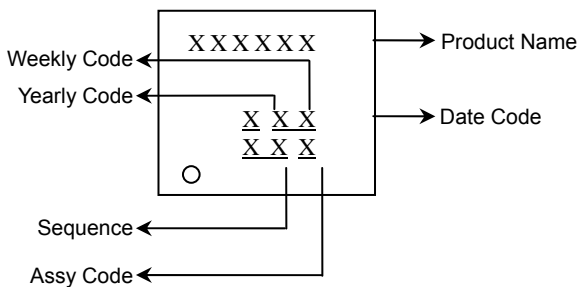

Note:

1. PACKAGE BODY SIZES EXCLUDE MOLD FLASH AND GATE BURRS.
2. CONTROLLING DIMENSION IS MILLIMETER CONVERTED INCH DIMENSIONS ARE NOT NECESSARILY EXACTLY.

Tape & Reel 繞捲及裝箱方式 (T0-252)

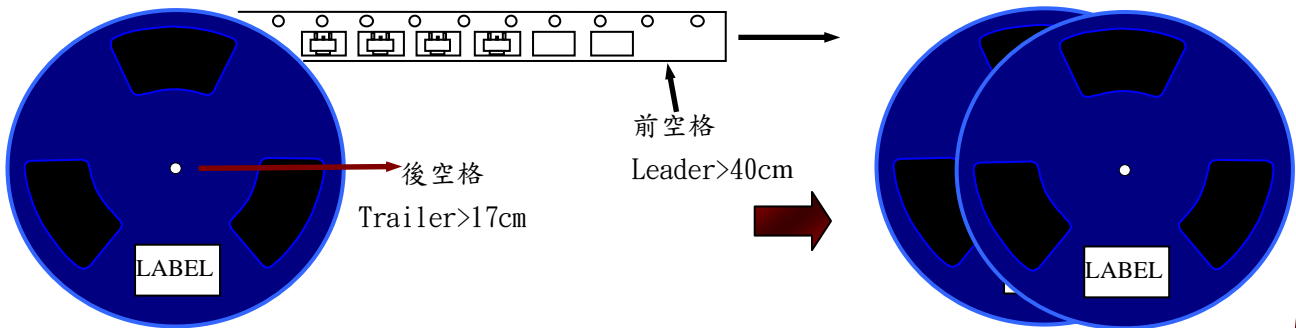

產品正印及方向 - (辨識點為左上時, Tape 圓孔在上方)

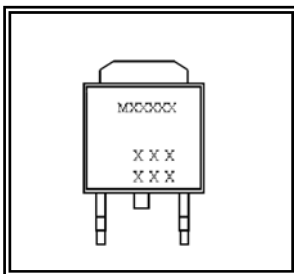

TO-252

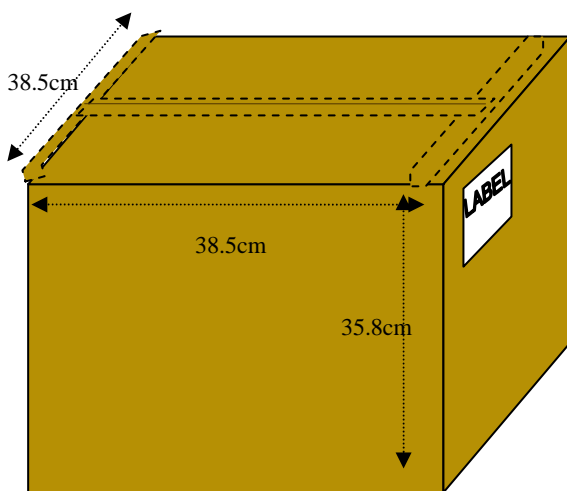
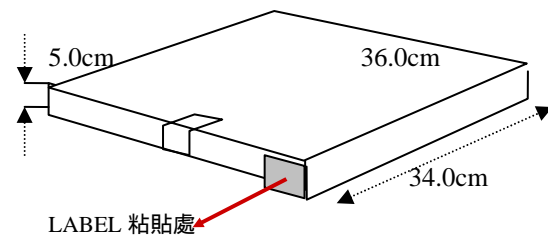

| 封裝形態 PKG TYPE | 一卷數量 Immediate Quantity | 中箱數量 Intermediate Quantity | 外箱裝置/數量 Carton Quantity |
|------------------|-------------------------------|----------------------------------|-------------------------------|
| TO-252(-4L) | 3000pcs | 6000pcs | 30K |
| | Reel (13") | Box(2 reels) | Carton(5 Box) |