

T-51-09-08

3021-1.0

# ZN426E8/ZN426D

## 8-BIT D-A CONVERTER

The ZN426 is a monolithic 8-bit D-A converter containing an R-2R ladder network of diffused resistors with precision bipolar switches and a 2.5V precision voltage reference.

**FEATURES**

- $\pm 1/2$  LSB Linearity Error
- Guaranteed Monotonic over the Full Operating Temperature Range
- 0°C to +70°C (ZN426E8, ZN426D)
- TTL and 5V CMOS Compatible
- Single +5V Supply
- Settling Time 1 microsecond Typical
- Only Reference Capacitor and Resistor Required

**ORDERING INFORMATION**

Device type	Operating temperature	Package
ZN426D	0°C to +70°C	MP16W
ZN426E-8	0°C to +70°C	DP14

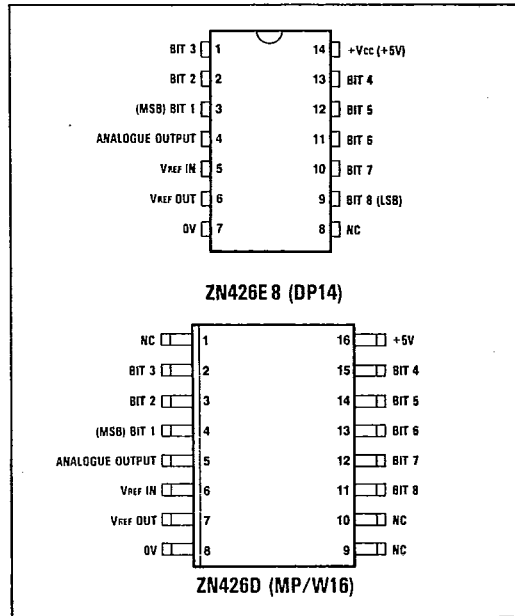

Pin connections - top view

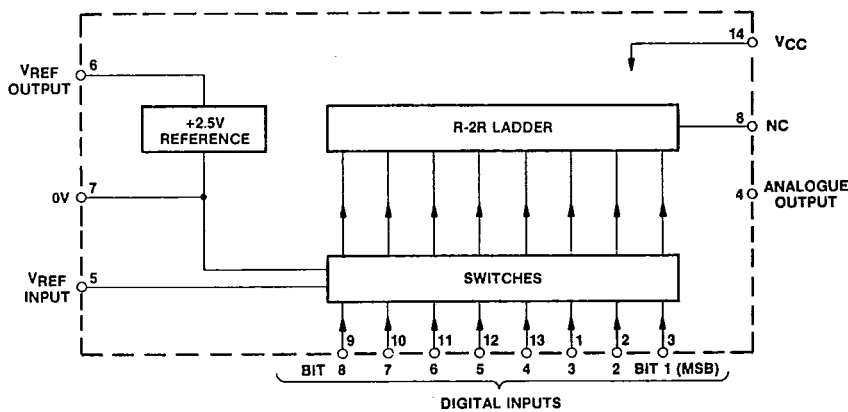

Fig.1 System diagram

**INTRODUCTION**

The ZN426 is an 8-bit D-A converter. It contains an advanced design of R-2R ladder network and an array of precision bipolar switches plus a 2.5V precision voltage reference all on a single monolithic chip.

The special design of ladder network results in full 8-bit accuracy using normal diffused resistors.

The use of the on-chip reference voltage is pin optional to retain flexibility. An external fixed or varying reference may therefore be substituted. In this case there is no need to supply power to the internal reference so  $R_{REF}$  and  $C_{REF}$  can be omitted

The converter is of the voltage switching type and uses an R-2R resistor ladder network as shown in Fig. 2.

T-51-09-08

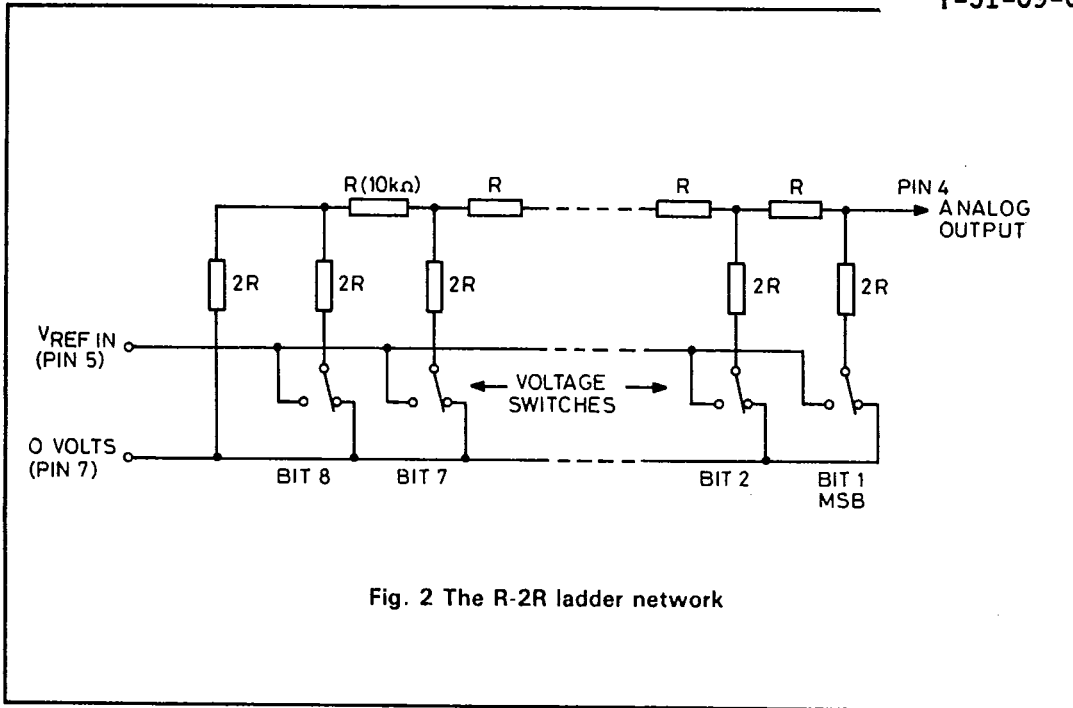

Fig. 2 The R-2R ladder network

Each 2R element is connected either to 0V or  $V_{REF}$  by transistor switches specially designed for low offset voltage (typically 1mV).

Binary weighted voltages are produced at the output of the R-2R ladder, the value depending on the digital number applied to the bit inputs.

**ABSOLUTE MAXIMUM RATINGS**

Supply voltage, $V_{CC}$	+7.0V
Max. voltage, logic and $V_{REF}$ inputs	+5.5V
Operating temperature range	0°C to 70°C (ZN426E 8, ZN426D)
Storage temperature range	-55°C to +125°C

ELECTRICAL CHARACTERISTICS ( $V_{CC} = +5V$ ,  $T_{amb} = 25^{\circ}C$  unless otherwise specified)

Parameter	Symbol	Min.	Typ.	Max.	Units	Conditions
Converter Resolution		8	-	-	bits	
Non-linearity		-	-	$\pm 0.5$	LSB	
Differential non-linearity		-	$\pm 0.5$	-	LSB	Note 1
Settling time to 0.5LSB		-	1.0	-	$\mu s$	1LSB step
Settling time to 0.5LSB		-	2.0	-	$\mu s$	All bits ON to OFF or OFF to ON
Offset voltage ZN426E8 and D	$V_{OS}$	-	3.0	5.0	mV	All bits OFF
$V_{OS}$ temperature coefficient		-	5	-	$\mu V/^{\circ}C$	
Full-scale output		2.545	2.550	2.555	V	All bits ON Ext. $V_{REF} = 2.560V$
Full-scale temp. coefficient		-	3	-	ppm/ $^{\circ}C$	Ext. $V_{REF} = 2.560V$
Non-linearity temp. coefficient		-	7.5	-	ppm/ $^{\circ}C$	Relative to F.S.R.

Notes

1. Monotonic over full temperature range.

## ELECTRICAL CHARACTERISTICS (cont.)

Parameter	Symbol	Min.	Typ.	Max.	Units	Conditions
Analogue output resistance	$R_o$	–	10	–	$k\Omega$	
External reference voltage		0	–	3.0	V	
Supply voltage	$V_{CC}$	4.5	–	5.5	V	
Supply current	$I_s$	–	5	9	mA	
High level input voltage	$V_{IH}$	2.0	–	–	V	
Low level input voltage	$V_{IL}$	–	–	0.7	V	
High level input current	$I_{IH}$	–	–	10	$\mu A$	$V_{CC} = \text{max.}$ $V_I = 2.4V$
		–	–	100	$\mu A$	$V_{CC} = \text{max.}$ $V_I = 5.5V$
Low level input current	$I_{IL}$	–	–	–0.18	mA	$V_{CC} = \text{max.}$ $V_I = 0.3V$
Internal voltage reference Output voltage	$V_{REF}$	2.475	2.55	2.626	V	Note* $R_{REF} = 390\Omega$
Slope resistance	$R_s$	–	1	2	$\Omega$	$R_{REF} = 390\Omega$
$V_{REF}$ temperature coefficient		–	40	–	ppm/ $^{\circ}C$	$R_{REF} = 390\Omega$

## NOTE\*

The internal reference requires a  $1\mu F$  stabilising capacitor between  $V_{REF OUT}$  and 0V and a  $390\Omega$  resistor,  $R_{REF}$ , between  $V_{CC}$  and  $V_{REF OUT}$ .

## APPLICATIONS

## 8-bit D-A converter

The ZN426 gives an analogue voltage output directly from pin 4 therefore the usual current to voltage converting amplifier is not required. The output voltage drift, due to the temperature coefficient of the analogue output resistance  $R_o$ , will be less than 0.004% per  $^{\circ}C$  (or 1LSB/100 $^{\circ}C$ ) if  $R_L$  is chosen to be  $\geq 650k\Omega$ .

In order to remove the offset voltage and to calibrate the converter a buffer amplifier is necessary. Fig. 3 shows a typical scheme using the internal reference voltage. To minimise temperature drift in this and similar applications the source resistance to the inverting input of the operational amplifier should be

approximately  $6k\Omega$ . The calibration procedure is as follows:

- i. Set all bits to OFF (low) and adjust  $R_2$  until  $V_{OUT} = 0.000V$ .
- ii. Set all bits to ON (high) and adjust  $R_1$  until  $V_{OUT} = \text{Nominal full-scale reading} - 1\text{LSB}$ .
- iii. Repeat i. and ii.

e.g.

Set F.S.R. to  $+3.840V - 1\text{LSB} = 3.825V$

$$(1\text{LSB} = \frac{3.84}{256} = 15.0\text{mV})$$

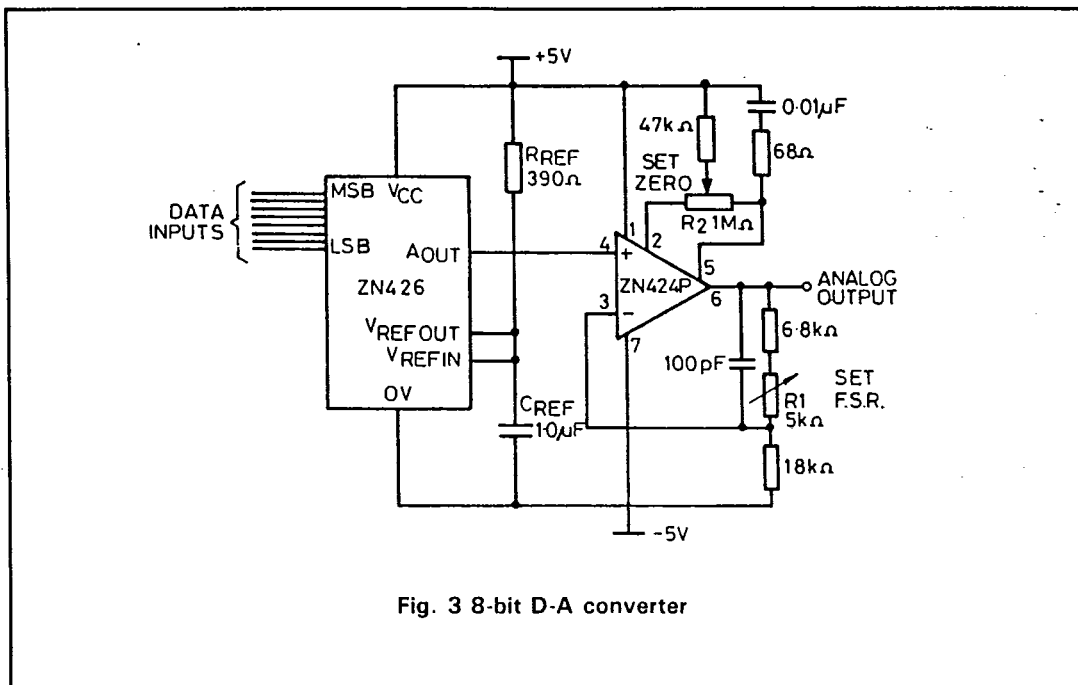

Fig. 3 8-bit D-A converter

**Alternative output buffer using the 741**

The circuit of Fig.4, employing the 741

operational amplifier, may be used as the output buffer.

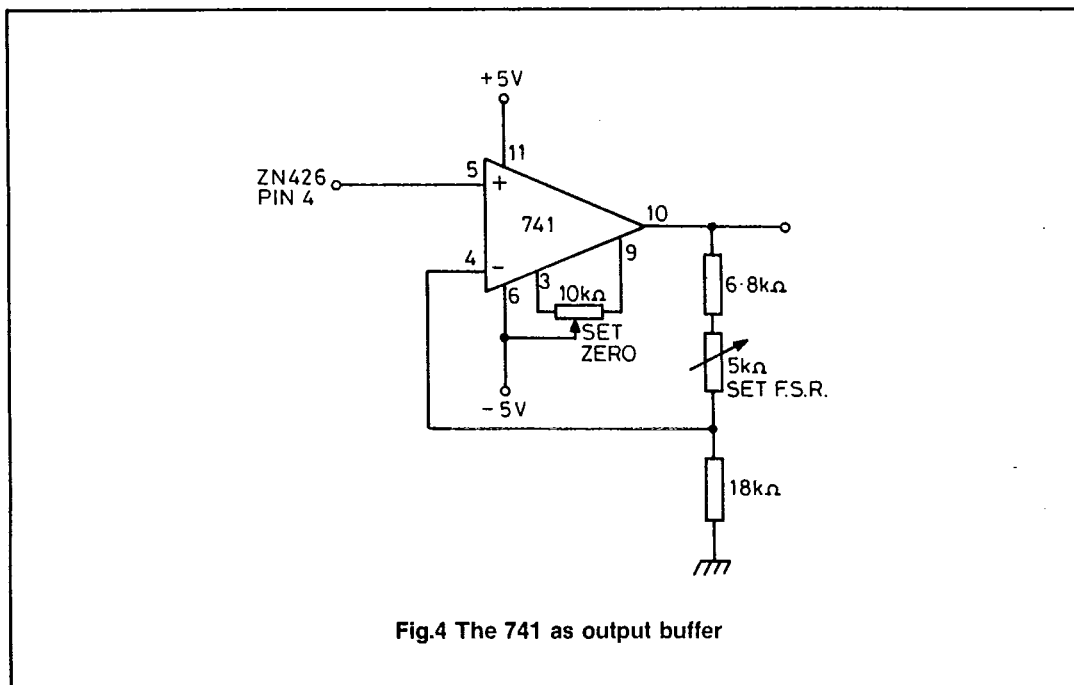

Fig.4 The 741 as output buffer