

RED INDICATES ORIGINAL

DASH NO	CABLES ACCOMMODATED	A DIM	B DIM	C FLATS	D FLATS	E DIA	CABLE ENTRY DIA	ASSEMBLE PER
-7	TRC-50-2 TRC-75-2	1.165	.096	.438	.438	.500	.274	TAI-189
-8	8227, BELDEN	1.740	.130	.625	.688	.750	.345	TAI-103
-9	TWC-78-2 TWC-124-2		.096	.438				
-A9	BL782, TIMES BL982, TIMES BL1242, TIMES	1.165	△	△	.438	.500	.285	TAI-102
-10	RG-22 754E, AT&T						.455	TAI-103
-11	760A, AT&T						.347	
-12	16PEVL, AT&T VI-AL, GENERAL	1.740	.130	.625	.688	.750	.485	TAI-128
-13	TRF-59, TIMES						.362	TAI-129
-13A	8232, BELDEN						.352	TAI-165
-14	8233, BELDEN						.490	TAI-129
-23	250-3884, MICRODOT						.183	TAI-189
-24	202-3934, MICRODOT						.191	TAI-102
-24A	9530A5117, RAYCHEM						.200	TAI-189
-25	T-43M, GENERAL						.285	TAI-102
-25A	5021H5331, RAYCHEM						.191	TAI-189
-26	7028A5518, RAYCHEM						.145	
-27	T19TPSJ2619EN, WOVEN 202-3927, MICRODOT 202-3942, MICRODOT						.145	TAI-102
-29	TWC-78-1/TWC-124-1A	1.165	.096	.438	.438	.500	.191	TAI-102
-30	761A, AT&T 8441, BELDEN						.235	
-32	TRC-50-1						.191	
-33	TRC-75-1						.217	
-42	21-204, ESSEX 4463, CONSOLIDATED						.300	TAI-189
-43	250-4044/250-4045 293-3930, MICRODOT						.200	
-45	M27500-22TE2T14 1100-66F, STANDARD						.183	TAI-102
-46	9860, BELDEN	1.740	.130	.625	.688	.750	.475	TAI-103
-47	M17/176-00002	1.165	.096	.438	.438	.500	.164	TAI-102
-49	TWAC-78-1F2						.132	
-54	89207, BELDEN	1.740	.130	.625	.688	.750	.323	TAI-103
-55	89272, BELDEN						.250	TAI-102
-56	GC8756C1, GRUMMAN						.191	TAI-189
-57	GC8756B1, GRUMMAN							
-58	GC8757M24H, GRUMMAN	1.165	.096	.438	.438	.500	.198	TAI-102
-59	GC8757LN1, GRUMMAN							
-60	M17/177, THERMATICS 380-10045, BOEING						.217	TAI-189
-64	7528A5314, RAYCHEM						.183	

MILITARY PART NO (PIN)	MILITARY CABLE PART NO	TROMPETER PART NO (REF ONLY)
M49142/08-0001	M17/134-00001	M315-0011-7
M49142/08-0002	M17/134-00002	M315-0011-7
M49142/08-0006	M17/176-00002	M315-0011-47
M49142/08-0008	M17/177-00002	M315-0011-60

DATA CONTAINED IN THIS DOCUMENT IS PROPRIETARY TO TROMPETER ELECTRONICS INC. AND SHALL NOT BE DISCLOSED, COPIED OR USED FOR PROCUREMENT OR MANUFACTURE WITHOUT EXPRESS WRITTEN PERMISSION

REV	ECO NO.	DESCRIPTION	DWN	APPROVED	DATE
AB	11468	REDRAWN IN PRO/E; REVISED NOTE 8 AND TABLE 1, ADDED NOTE 9	LSR	<i>[Signature]</i>	

INCH	MM
.002	0.05
.005	0.13
.029	0.74
.030	0.76
.096	2.44
.125	3.18
.130	3.30
.132	3.35
.145	3.68
.164	4.17
.183	4.65
.191	4.85
.198	5.03
.200	5.08
.217	5.51
.235	5.97
.250	6.35
.274	6.96
.285	7.24
.300	7.62

INCH	MM
.323	8.20
.345	8.76
.347	8.81
.352	8.94
.362	9.19
.438	11.13
.440	11.18
.455	11.56
.475	12.07
.485	12.32
.490	12.45
.500	12.70
.625	15.88
.650	16.51
.688	17.48
.750	19.05
1.165	29.59
1.740	44.20
1.846	46.89
2.00	50.80

FIG 1
PL375S-9 SHOWN

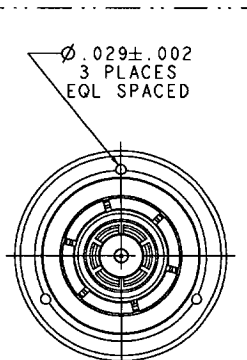

SCALE 4/1
SAFETY WIRE OPTION

FIG 2
PL375BR-9 SHOWN

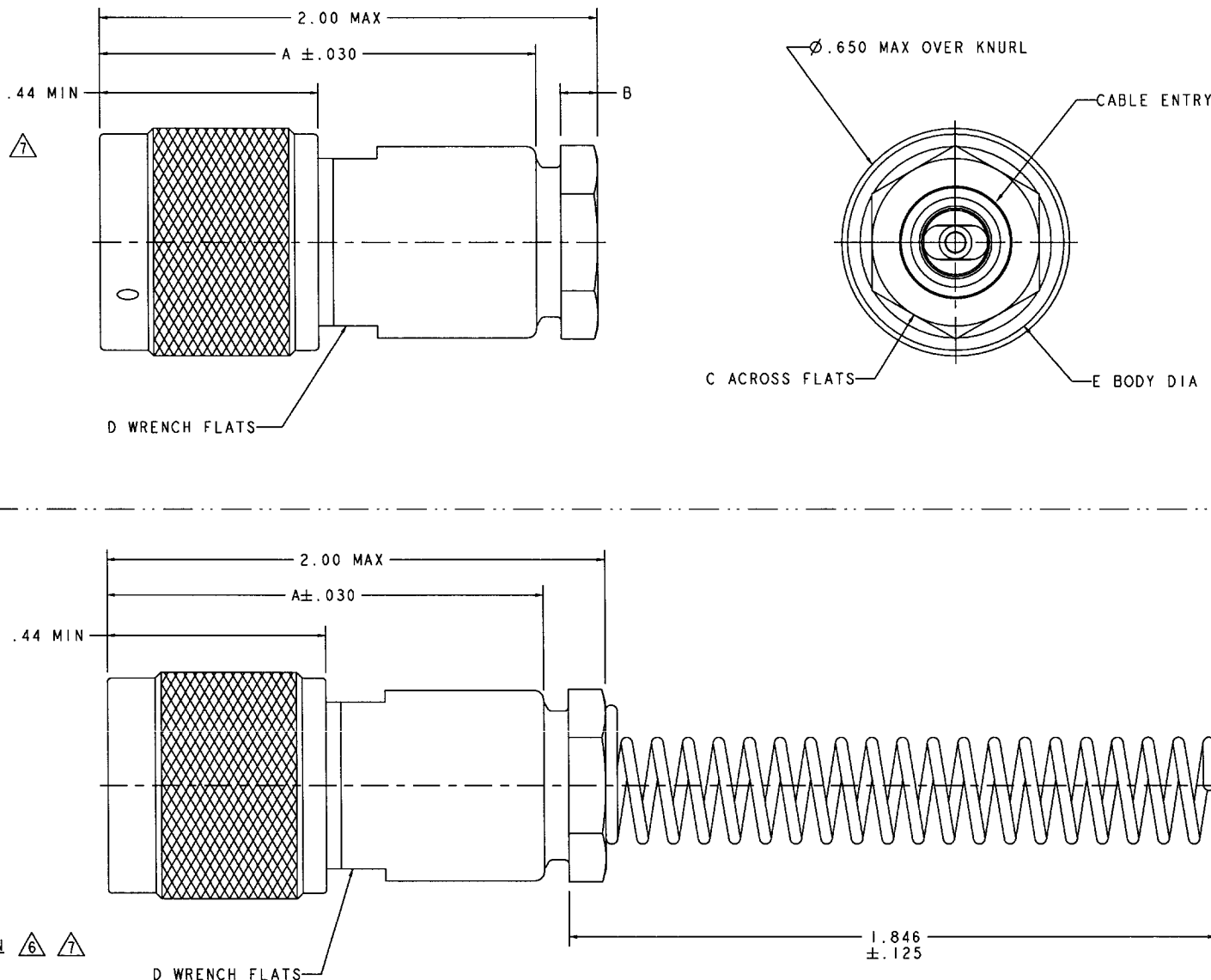

MODEL NO	DASH NO/CABLE GROUP																
PL75 (TWINAX)	-8	-9	-A9	-10	-11	-12	-24	-25	-27	-29	-30	-45	-46	-47	-49	-54	-55
PL75 (TRIAx)	-7	-13	-13A	-14	-23	-24A	-25A	-26	-32	-33	-42	-43	-56	-57	-59	-60	-64
PL75 (QUADRAX)	-58																

- △ IF SAFETY WIRE TYPE & BEND RELIEF SPRING REQD ADD SUFFIX "SBR" TO MODEL NO (NOT AVAILABLE WITH CABLE GROUPS -8, -10, -11, -12, -13, -13A, -14, -46, & -54)
- △ IF BEND RELIEF SPRING REQD (SEE FIG 2) ADD SUFFIX "BR" TO MODEL NO (NOT AVAILABLE WITH CABLE GROUPS -8, -10, -11, -12, -13, -13A, -14, -46, & -54)
- 5. IF SAFETY WIRE TYPE REQD ADD SUFFIX "S" TO MODEL NO (PL375S)
- △ CLAMP NUT OMITTED
- 3. CONCENTRIC TWINAX/TRIAx TRT CABLE PLUG
- 2. FINISH: TFS-1A (NICKEL) △
- 1. ALL DIM ARE IN INCHES

9. EXAMPLE OF COMPLETE MODEL NO:
- PL375 S BR-7
- BASIC MODEL NO — SAFETY WIRE TYPE (OMIT IF NOT REQD) — DASH NO (CABLE GROUP, TABLE 1) — BEND RELIEF (OMIT IF NOT REQD)
- △ WHEN CONNECTOR IS SUPPLIED TO MILITARY PART NO. (SEE TABLE 2):
- a) ALL PARTS NORMALLY PLATED TFS-1A OR TFS-1U (NICKEL) ARE TO BE PLATED TFS-1M (SILVER)
 - b) MARK PART WITH MILITARY PIN (SEE TABLE 2) AND "14949"
 - c) QUALITY CONFORMANCE INSPECTION SHALL BE PER MIL-C-49142 SECTION 4.5

QTY	DESCRIPTION	PART NUMBER	ITEM
TOL UNLESS SPECIFIED	TROMPETER ELECTRONICS, INC®		PL375/PL375S
II ± .005	PL375BR/PL375SBR		
III ± .005	MATERIAL		CODE IDENT
IV ± .005	14949		DRAWING NO.
CRITICAL	315-0011		AB
DWG LSR 8-21-96	DATE 5/23/73		SHEET 1 OF 2
CHK <i>[Signature]</i> 8-23-96	SCALE 5/1		
ENGR	NEXT ASSY APPR <i>[Signature]</i> 8/23/96		