



SANYO Semiconductors

# DATA SHEET

## LA4915 — Monolithic Linear IC TV BTL 5W typical 2-channel BTL high-efficiency power amplifier

### Overview

The LA4915 is a BTL two-channel power amplifier for use in TV audio systems. Increases in the number of external components are held to a minimum by adopting both a signal-following type switching scheme in the amplifier's output stage power supply, and a nonlinear amplifier that has nonlinear characteristics in the signal system. The power dissipation (thermal loss) in the actual operating range has been reduced to about 1/2 that of earlier class B amplifier ICs. When used with the DIP-28HC package, the IC dispenses with the heat sink and significantly contributes to space saving in the end product case.

### Functions

- High-efficiency 5W+5W power amplifier
- Encapsulated in a DIP-28HC package (heat sink free)
- Requires only one signal-following type switching circuit, contributing to a reduction in the number of external components
- Provides analog outputs that generate no switching noise on the output lines
- Built-in standby switches (amplifier and headphone amplifier blocks)
- Built-in headphone amplifier with 2 inputs and 2 outputs (VG=6dB, P<sub>O</sub>=30mW)
- Built-in protection circuits (overvoltage and thermal protection circuits)

### Applications

- Audio output for TV application

### Specifications

Maximum Ratings at Ta = 25°C

Parameter	Symbol	Conditions	Ratings	Unit
Maximum supply voltage	V <sub>CC</sub> max	No signal	24	V
Allowable power dissipation	P <sub>d</sub> max	With an infinitely large heat sink	5	W
Maximum junction temperature	T <sub>j</sub> max		150	°C
Thermal resistance	θ <sub>jc</sub>		3	°C/W
Operating temperature	T <sub>opr</sub>		-25 to +75	°C
Storage temperature	T <sub>stg</sub>		-40 to +150	°C

■ Any and all SANYO Semiconductor products described or contained herein do not have specifications that can handle applications that require extremely high levels of reliability, such as life-support systems, aircraft's control systems, or other applications whose failure can be reasonably expected to result in serious physical and/or material damage. Consult with your SANYO Semiconductor representative nearest you before using any SANYO Semiconductor products described or contained herein in such applications.

■ SANYO Semiconductor assumes no responsibility for equipment failures that result from using products at values that exceed, even momentarily, rated values (such as maximum ratings, operating condition ranges, or other parameters) listed in products specifications of any and all SANYO Semiconductor products described or contained herein.

**SANYO Semiconductor Co., Ltd.**

TOKYO OFFICE Tokyo Bldg., 1-10, 1 Chome, Ueno, Taito-ku, TOKYO, 110-8534 JAPAN

# LA4915

## Operating Conditions at $T_a = 25^\circ\text{C}$

Parameter	Symbol	Conditions	Ratings	Unit
Recommended supply voltage	$V_{CC}$		10.5	V
Recommended load resistance	$R_L$	AMP block	8	$\Omega$
Recommended load resistance	$R_L$	H/P block	32	$\Omega$
Operating supply voltage range	$V_{CC\text{ op}}$	Not exceeding the package $P_d$	7 to 18	V

## Electrical Characteristics

### Operating Characteristics at $T_a = 25^\circ\text{C}$ , $V_{CC} = 10.5\text{V}$ , $R_L = 8\Omega$ , $f = 1\text{kHz}$ , $R_g = 600\Omega$ ,

See the specified board and circuit.

#### AMP block

Parameter	Symbol	Conditions	Ratings			Unit
			min	typ	max	
Quiescent current	$I_{CCO}$	$R_g = 0$	35	65	120	mA
Standby current	$I_{st}$			0	10	$\mu\text{A}$
Voltage gain	VG	$V_O = 0\text{dBm}$	28	30	32	dB
Output power	$P_O$	THD = 10%	4	5		W
Total harmonic distortion	THD	$P_O = 1\text{W}$ , LPF = 30kHz		0.04	0.4	%
Output noise voltage	$V_{NO}$	$R_g = 0$ , DIN AUDIO		0.05	0.3	mV
Channel selectivity	CHsep	$R_g = 10\text{k}\Omega$ , $V_O = 0\text{dBm}$ , DIN AUDIO	50	60		dB
Ripple rejection	SVRR	$R_g = 0$ , $f_R = 100\text{Hz}$ , $V_R = 0\text{dBm}$ , DIN AUDIO	60	70		dB
Input resistance	$R_i$		21	30	39	$\text{k}\Omega$
Output offset voltage	$V_{N\text{ offset}}$	$R_g = 0$	-200		+200	mV
Standby OFF voltage	$V_{ST}$	AMP = ON, Application via 10k $\Omega$	3		$V_{CC}$	V
Pin 7 inrush current (DDL ON current)	$I_{7\text{Pin}}$	Apply +5V to pin via 10k $\Omega$ , THD = 10%	100	150	200	$\mu\text{A}$

\*DDL : Stands for Dynamic Distortion Limiter.

### Operating Characteristics at $T_a = 25^\circ\text{C}$ , $V_{CC} = 10.5\text{V}$ , $R_L = 32\Omega$ , $f = 1\text{kHz}$ , $R_g = 600\Omega$ ,

See the specified board and circuit.

#### H/P block

Parameter	Symbol	Conditions	Ratings			Unit
			min	typ	max	
Voltage gain	VG	$V_O = 0\text{dBm}$	4.5	5.5	6.5	dB
Output power	$P_O$	THD = 1%	25	30		mW
Total harmonic distortion	THD	$V_O = 0\text{dBm}$ , LPF = 30kHz		0.025	0.05	%
Channel selectivity	CH sep	$R_g = 10\text{k}\Omega$ , $V_O = 0\text{dBm}$ , DIN AUDIO	50	60		dB
Ripple rejection	SVRR	$R_g = 0$ , $f_R = 100\text{Hz}$ , $V_R = 0\text{dBm}$ , DIN AUDIO	65	75		dB
Output noise voltage	$V_{NO}$	$R_g = 0$ , DIN AUDIO		0.01	0.04	mV
Standby OFF voltage	$V_{ST}$	H/P AMP = ON, Application via 10k $\Omega$	3		$V_{CC}$	V

\*1 : DIN AUDIO (20Hz to 20kHz)

Package Dimensions

unit : mm

3241A

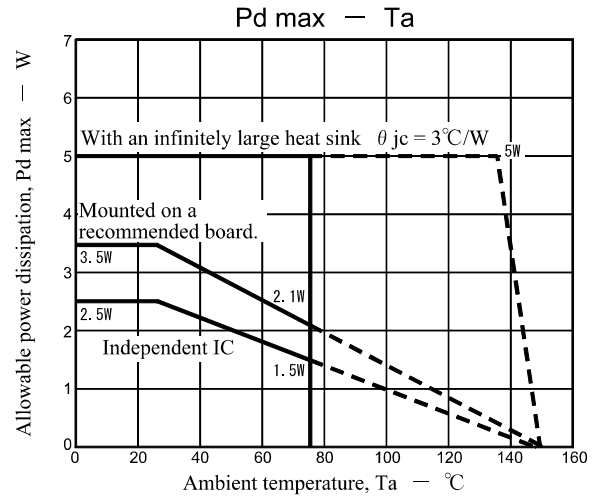
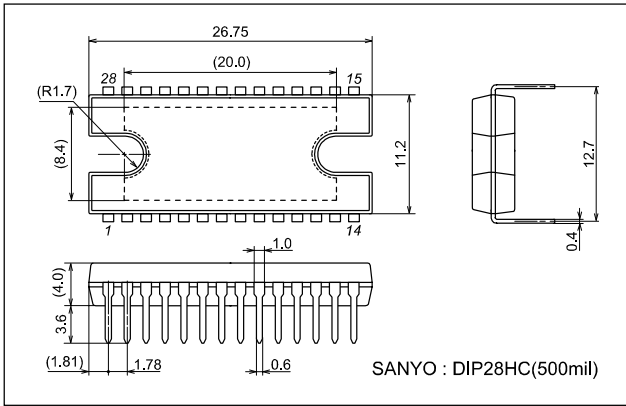

# LA4915

## Block Diagram

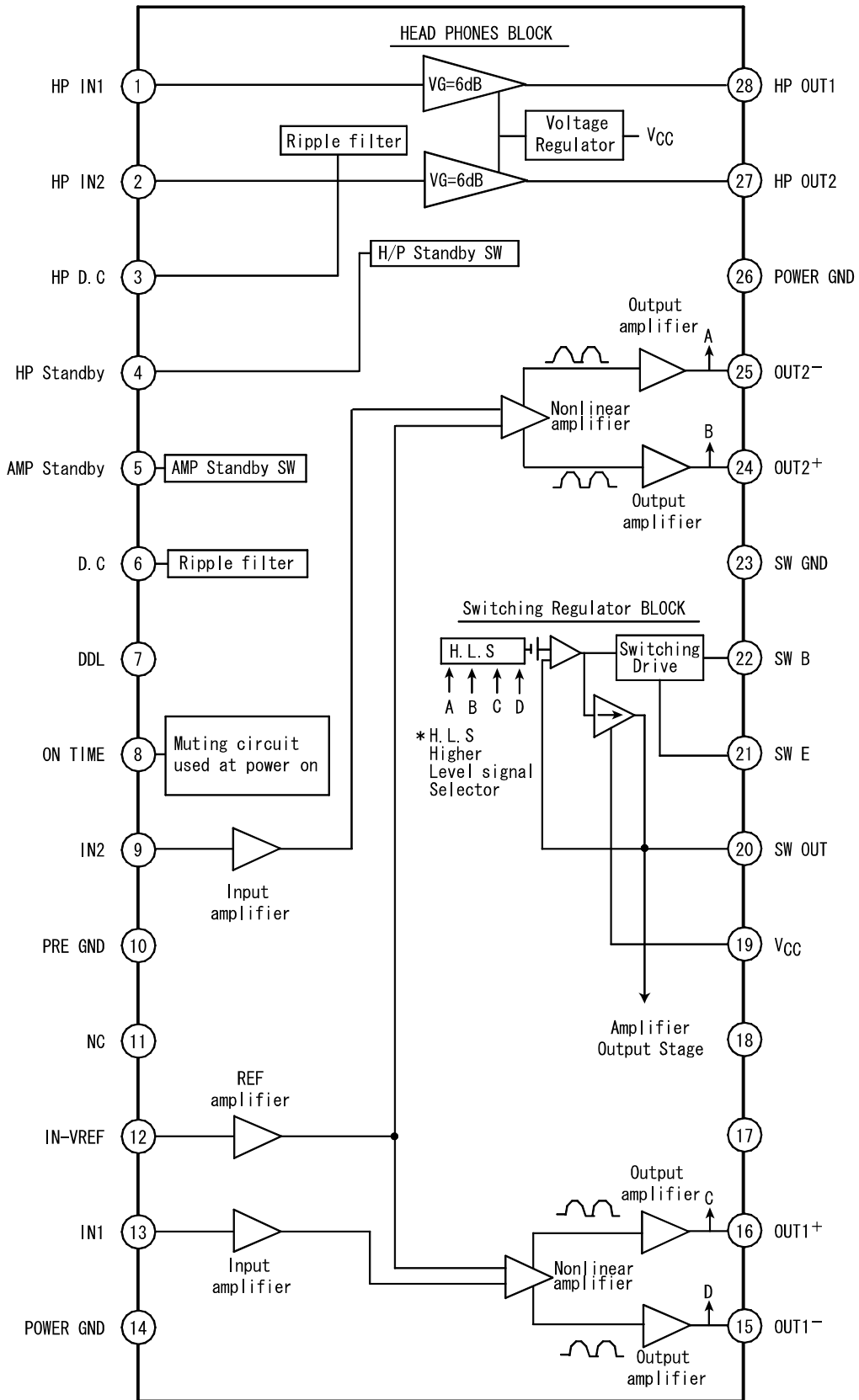

Sample Application Circuit

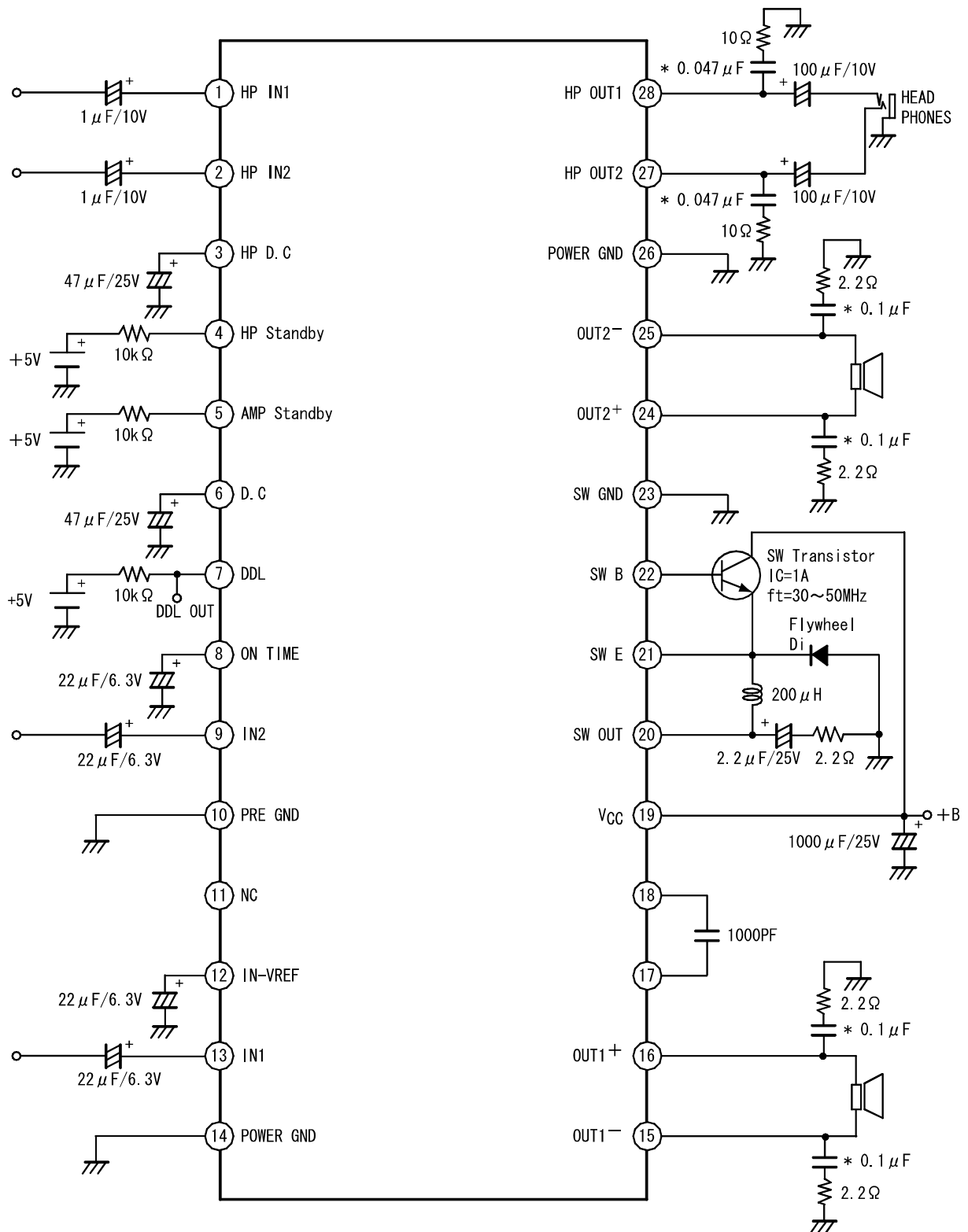

\* Polyester film capacitor

- Specifications of any and all SANYO Semiconductor products described or contained herein stipulate the performance, characteristics, and functions of the described products in the independent state, and are not guarantees of the performance, characteristics, and functions of the described products as mounted in the customer's products or equipment. To verify symptoms and states that cannot be evaluated in an independent device, the customer should always evaluate and test devices mounted in the customer's products or equipment.
- SANYO Semiconductor Co., Ltd. strives to supply high-quality high-reliability products. However, any and all semiconductor products fail with some probability. It is possible that these probabilistic failures could give rise to accidents or events that could endanger human lives, that could give rise to smoke or fire, or that could cause damage to other property. When designing equipment, adopt safety measures so that these kinds of accidents or events cannot occur. Such measures include but are not limited to protective circuits and error prevention circuits for safe design, redundant design, and structural design.
- In the event that any or all SANYO Semiconductor products (including technical data, services) described or contained herein are controlled under any of applicable local export control laws and regulations, such products must not be exported without obtaining the export license from the authorities concerned in accordance with the above law.
- No part of this publication may be reproduced or transmitted in any form or by any means, electronic or mechanical, including photocopying and recording, or any information storage or retrieval system, or otherwise, without the prior written permission of SANYO Semiconductor Co., Ltd.
- Any and all information described or contained herein are subject to change without notice due to product/technology improvement, etc. When designing equipment, refer to the "Delivery Specification" for the SANYO Semiconductor product that you intend to use.
- Information (including circuit diagrams and circuit parameters) herein is for example only; it is not guaranteed for volume production. SANYO Semiconductor believes information herein is accurate and reliable, but no guarantees are made or implied regarding its use or any infringements of intellectual property rights or other rights of third parties.

This catalog provides information as of June, 2005. Specifications and information herein are subject to change without notice.