



LV8804V

Bi-CMOS LSI
PC and Server
Fan Motor Driver

Overview

The LV8804V is a motor driver for PC and server fans.

Feature

- Direct PWM 3-phase sensorless motor driver

Specifications

Absolute Maximum Ratings at Ta = 25°C

Parameter	Symbol	Conditions	Ratings	Unit
V _{CC} maximum supply voltage	V _{CC} max		16	V
VG maximum supply voltage	VG max		21	V
OUT pin maximum output current	I _{OUT} max	UO, VO, and WO pins	1.2	A
SOFTST pin withstand voltage	V _{SOFTST} max		6	V
FR pin withstand voltage	V _{FR} max		6	V
CTL pin withstand voltage	V _{CTL} max		6	V
MINSNP pin withstand voltage	V _{MINSNP} max		6	V
FG output pin withstand voltage	V _{FG} max		16	V
FG pin maximum output current	I _{FG} max		5	mA
1/2FG output pin withstand voltage	V _{1/2FG} max		16	V
1/2FG pin maximum output current	I _{1/2FG} max		5	mA
RD output pin withstand voltage	V _{RD} max		16	V
RD pin maximum output current	I _{RD} max		5	mA
Allowable Power dissipation 1	P _d max1	Independent IC	0.6	W
Allowable Power dissipation 2	P _d max2	Mounted on designated board *	1.3	W
Operating temperature	T _{opr}		-40 to +85	°C
Storage temperature	T _{stg}		-55 to +150	°C

* : When mounted on the designated 76.1mm × 114.3mm × 1.6mm, glass epoxy board (single-layer)

■ Any and all SANYO Semiconductor Co.,Ltd. products described or contained herein are, with regard to "standard application", intended for the use as general electronics equipment (home appliances, AV equipment, communication device, office equipment, industrial equipment etc.). The products mentioned herein shall not be intended for use for any "special application" (medical equipment whose purpose is to sustain life, aerospace instrument, nuclear control device, burning appliances, transportation machine, traffic signal system, safety equipment etc.) that shall require extremely high level of reliability and can directly threaten human lives in case of failure or malfunction of the product or may cause harm to human bodies, nor shall they grant any guarantee thereof. If you should intend to use our products for applications outside the standard applications of our customer who is considering such use and/or outside the scope of our intended standard applications, please consult with us prior to the intended use. If there is no consultation or inquiry before the intended use, our customer shall be solely responsible for the use.

■ Specifications of any and all SANYO Semiconductor Co.,Ltd. products described or contained herein stipulate the performance, characteristics, and functions of the described products in the independent state, and are not guarantees of the performance, characteristics, and functions of the described products as mounted in the customer's products or equipment. To verify symptoms and states that cannot be evaluated in an independent device, the customer should always evaluate and test devices mounted in the customer's products or equipment.

LV8804V

Allowable Operating Conditions at $T_a = 25^\circ\text{C}$

Parameter	Symbol	Conditions	Ratings	Unit
V_{CC} supply voltage	V_{CC}		6 to 15	V
SOFTST input voltage range	V_{SOFTST}		0 to VREG	V
FR input voltage range	V_{FR}		0 to VREG	V
CTL input voltage range	V_{CTL}		0 to VREG	V
MINSP input voltage range	V_{MINSP}		0 to VREG	V

Electrical Characteristics at $T_a = 25^\circ\text{C}$, $V_{CC} = 12\text{V}$, unless otherwise specified

Parameter	Symbol	Conditions	Ratings			Unit
			min	typ	max	
Circuit current 1	I_{CC1}			3	4	mA
Charge pump block						
Charge pump output voltage	V_{VG}			17		V
Regulator block						
5V regulator voltage	V_{VREG}		4.75	5	5.25	V
Output on resistance						
High-side output transistor on resistance	$R_{on (H)}$	$I_O = 0.7\text{A}$, $V_G = 17\text{V}$		0.6	1.0	Ω
Low-side output transistor on resistance	$R_{on (L)}$	$I_O = 0.7\text{A}$, $V_{CC} = 12\text{V}$		0.6	1.0	Ω
Sum of high-/low-side output transistor on resistance	$R_{on (H+L)}$	$I_O = 0.7\text{A}$, $V_{CC} = 12\text{V}$, $V_G = 17\text{V}$		1.2	2	Ω
Startup oscillator (OSC) pin						
OSC pin charge current	I_{OSCC}			-2.5		μA
OSC pin discharge current	I_{OSCD}			2.5		μA
Control voltage input (CTL) pin						
Motor drive on voltage input range	V_{CTLON}		0		3	V
Motor drive off voltage input range	V_{CTLOFF}		3.5		VREG	V
Minimum speed setting pin						
Minimum speed setting voltage input range	V_{MINSP1}		1		3	V
Minimum speed releasing voltage input range	V_{MINSP2}		4		VREG	V
Forward/reverse switching pin						
High-level input voltage range	V_{FRH}	Order of current application : UOUT→VOUT→WOUT	4		VREG	V
Low-level input voltage range	V_{FRL}	Order of current application : UOUT→WOUT→VOUT	0		1	V
FG, 1/2FG, and RD output pins						
FG output pin low-level voltage	V_{FG}	When I_O is 2mA		0.25	0.35	V
1/2FG output pin low-level voltage	$V_{1/2FG}$	When I_O is 2mA		0.25	0.35	V
RD output pin low-level voltage	V_{RD}	When I_O is 2mA		0.25	0.35	V
Current limiter circuit						
Limiter voltage	V_{RF}	Limit current set to 1A when R_F is 0.25 Ω .	0.225	0.25	0.275	V
Constraint protection circuit						
CT pin high-level voltage	V_{CTH}		2.25	2.8	2.95	V
CT pin low-level voltage	V_{CTL}		0.43	0.5	0.65	V
CT pin charge current	I_{CTC}		-2.9	-2.5	-2.2	μA
CT pin discharge current	I_{CTD}		0.23	0.25	0.32	μA
ICT charge/discharge ratio	R_{CT}		7	10	13	
Soft start circuit						
Soft start releasing voltage	V_{SOFTST}			2.5		V
SOFTST pin charge current	I_{SOFTST}			0.6		μA
Thermal protection circuit						
Thermal protection circuit operating temperature	TSD	Design target *	150	180	210	$^\circ\text{C}$

* : Design target value and no measurement is made. The thermal protection circuit is incorporated to protect the IC from burnout or thermal destruction. Since it operates outside the IC's guaranteed operating range, the customer's thermal design should be performed so that the thermal protection circuit will not be activated when the fan is running under normal operating conditions.

LV8804V

Package Dimensions

unit : mm (typ)
3361

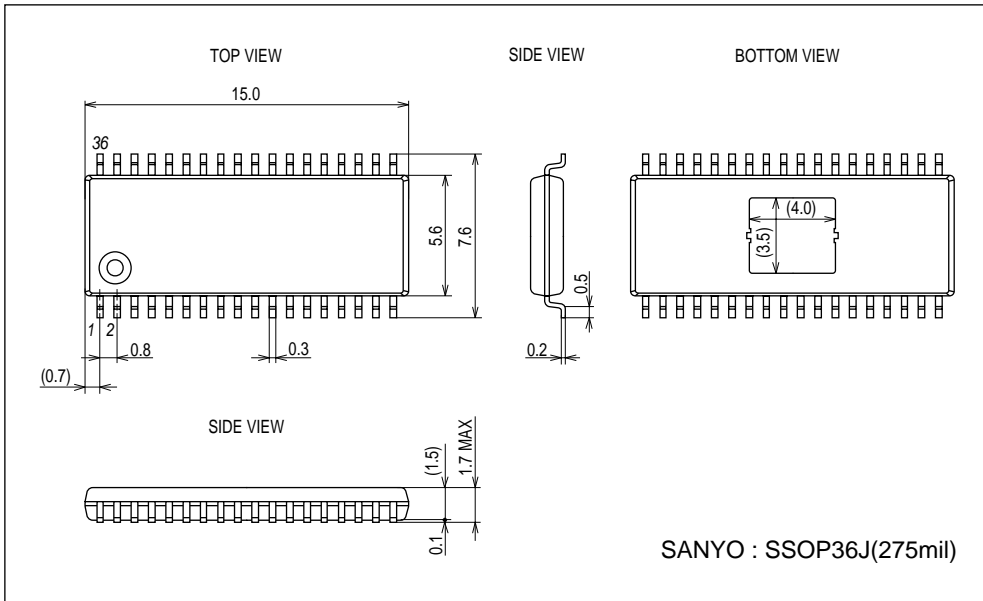

Pin Assignment

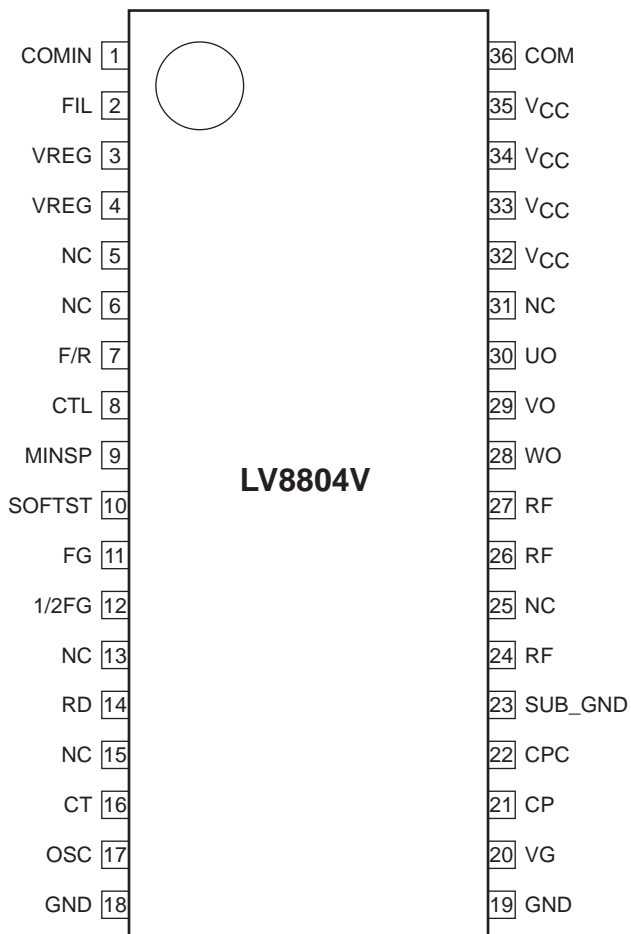

Top view

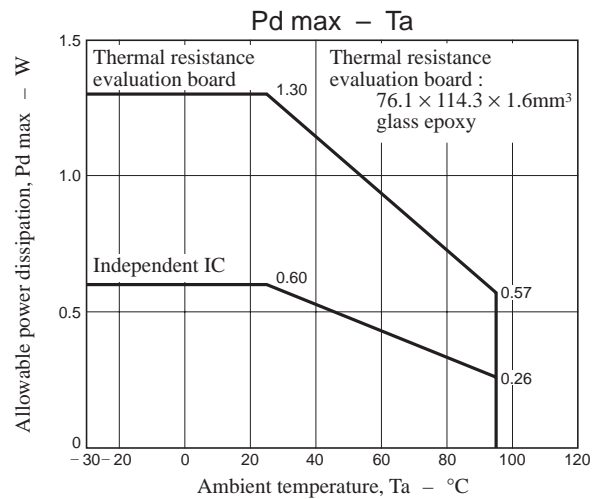

LV8804V

Block Diagram

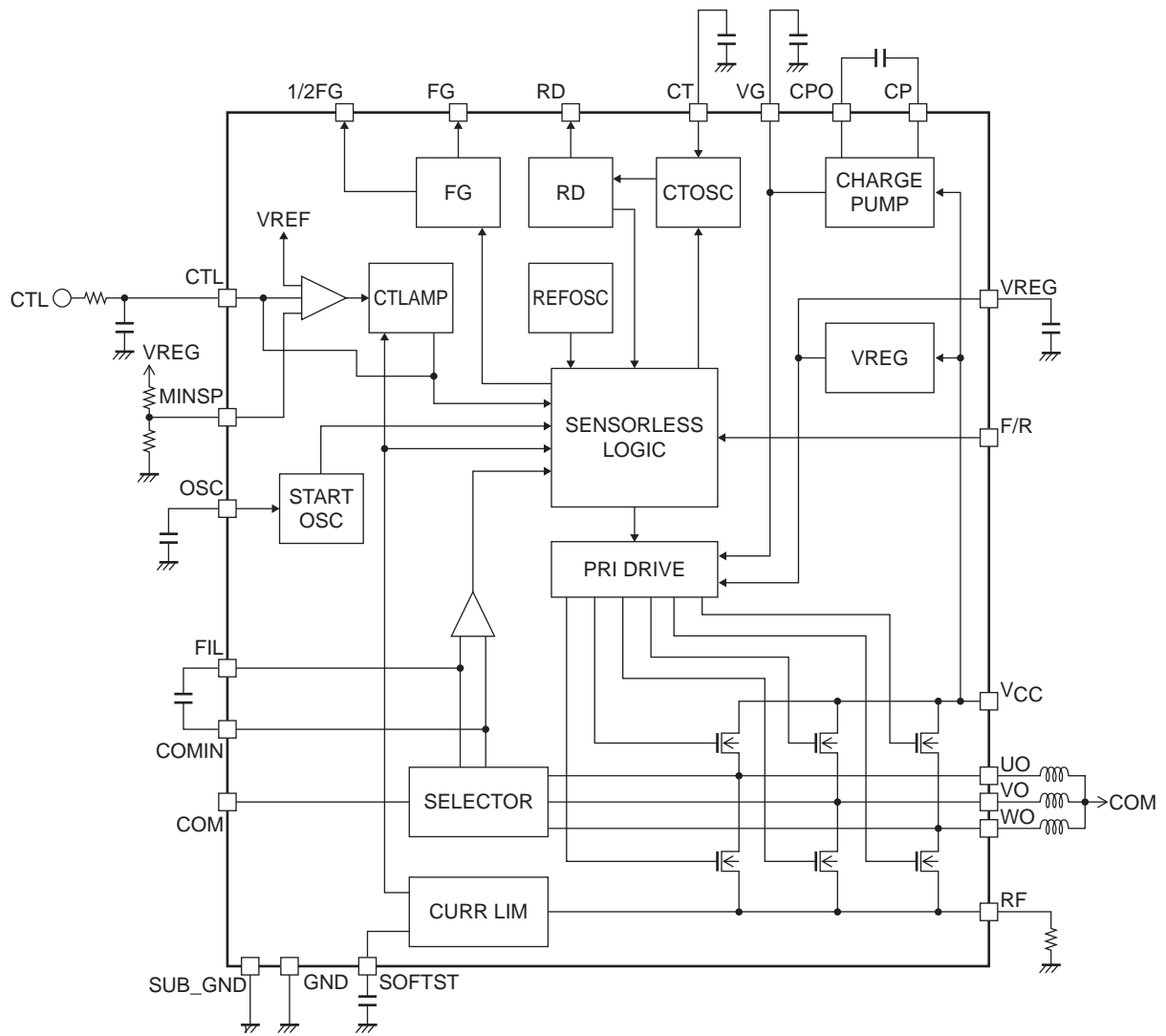

LV8804V

Pin Function

Pin No.	Pin name	Function	Equivalent circuit
36	COM	Motor middle point connection.	
1	COMIN	Motor position detection comparator filter pin. A capacitor must be connected between this pin and the FIL pin (pin 2).	
2	FIL	Motor position detection comparator filter pin. A capacitor must be connected between this pin and the COMIN pin (pin 5).	
3 4	VREG	Regulator voltage (5V) output. A capacitor must be connected between these pins and ground.	
5, 6, 13, 15, 25, 31	NC	No connection. These pins are not connected with the internal parts.	
7	F/R	Motor rotation direction switching. A high-level input causes current to flow into the motor in the order of U, V, and W and a low-level input in the order of U, W, and V. Changing the order of current application turns the motor in the opposite direction.	
8	CTL	Motor control voltage input. When the control voltage is higher than 3 V ($3V < CTL$ voltage), the motor stops. The motor speed is controlled by varying the control voltage within the range of 3V to 1V ($3V > CTL$ voltage $> 1V$). When the control voltage becomes lower than 1V ($1V > CTL$ voltage), the current limit set by the RF resistor is reached.	
9	MINSP	Minimum speed setting voltage input. The minimum speed of the motor can be set by resistor-dividing the regulator voltage and feeding the resultant voltage that is within the range of 1V to 3V ($1V < MINSP < 3V$).	
10	SOFTST	Soft start time setting. The motor can be started smoothly by connecting a capacitor between this pin and ground.	

Continued on next page.

LV8804V

Continued from preceding page.

Pin No.	Pin name	Function	Equivalent circuit
11	FG	FG pulse output. This pin outputs a Hall sensor system equivalent pulse signal.	
12	1/2FG	FG pulse output. This pin outputs 1/2 Hall sensor system equivalent pulse signal.	
14	RD	Motor lockup detection output. Output is fixed high when motor is locked up.	
16	CT	Motor lockup detection time setting. When the motor lockup condition is detected, the protection time period before the protection circuit is activated is set by connecting a capacitor between this pin and ground.	
17	OSC	Motor startup frequency setting. A capacitor must be connected between this pin and ground. The startup frequency is adjusted by controlling the charge/discharge current and capacitance of the capacitor.	
18, 19	GND	GND pin.	
20	VG	Charge pump step-up voltage output. A capacitor must be connected between this pin and the V _{CC} pin or ground.	
21	CP	Charge pump step-up pulse output pin. A capacitor must be connected between this pin and the CPC pin (pin 22).	
22	CPC	Charge pump step-up pin. A capacitor must be connected between this pin and the CP pin (pin 21).	
23	SUB_GND	GND pin.	
32, 33, 34, 35	V _{CC}	Power supply for the IC and motor. Capacitors must be connected between these pins and ground.	
30	UO	Output pins. Connect these pins to the U, V, and W of the motor coil.	
29	VO		
28	WO		
24, 26, 27	RF	Output current detection pins. The drive current is detected by connecting a resistor between these pins and ground.	

LV8804V Functional Description

1 Control Characteristics

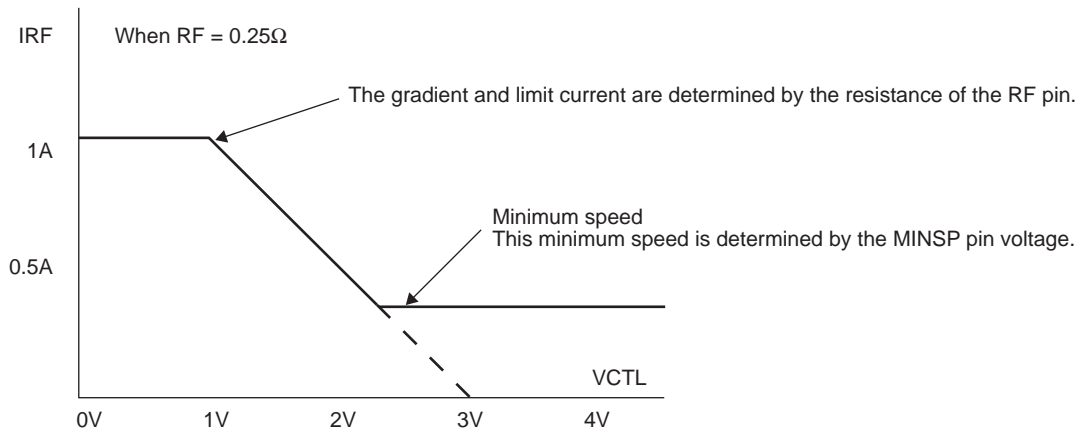

The current flowing to the motor and the control characteristics are determined by adjusting the resistance of the RF resistor.

By connecting a resistor with a resistance of 0.25Ω between the RF pin and GND, the limit current is set at a motor current of 1A, and the control characteristics shown in the diagram above are achieved.

By increasing the RF resistance, the limit current is reduced; conversely, by reducing the RF resistance, the limit current is increased.

Since $I_{O\ max.}$ is 1.2A, the RF resistance must be set in such a way that the current flowing to the motor does not exceed this maximum value.

By varying the CTL voltage between 1V and 3V, the current flowing to the output is limited.

PWM control is exercised within the voltage range above (1V to 3V) to control the motor speed.

When the CTL voltage is less than 1V, the current limiter value determined by the RF resistance is reached, and the motor speed is limited.

When the CTL voltage is greater than 3V, PWM is reduced to 0%, and the motor stops. (However, the motor does not stop if the minimum speed has been set.)

The minimum speed can be set by resistor-dividing the REG voltage (5V) to create a voltage of 1V to 3V, and inputting this voltage to the MINSP pin.

If the minimum speed is not going to be set, the MINSP pin and CTL pin (pin 8) must be short-circuited.

2. Timing at Startup (soft start)

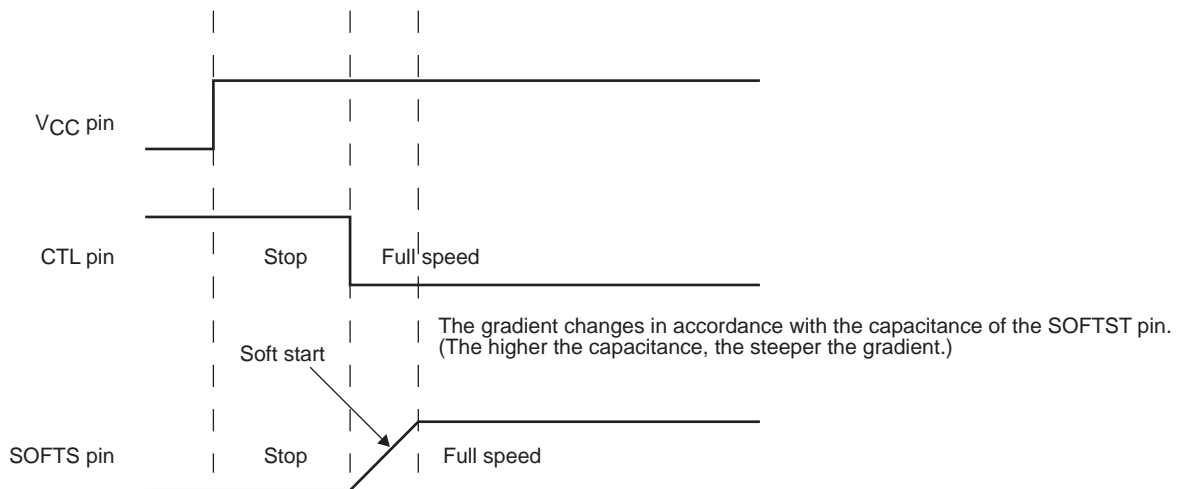

Application Circuit Example

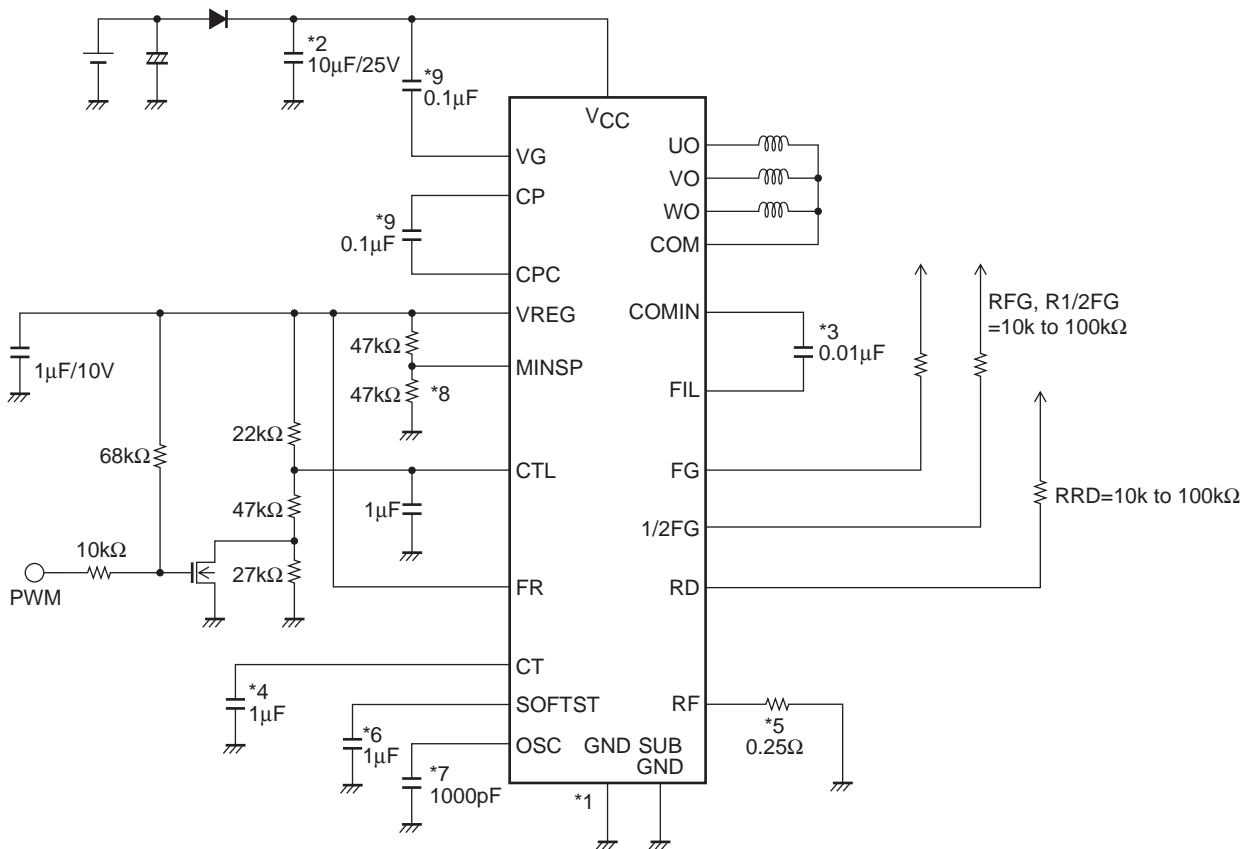

*1. Power supply and GND wiring

The GND is connected to the control circuit power supply system.

*2. Power-side power stabilization capacitor

For the power-side power stabilization capacitor, use a capacitor of 10µF or more.

Connect the capacitor between VCC and GND with a thick and along the shortest possible route.

The VCC pins (pins 32, 33, 34, and 35) must be short-circuited on the print pattern.

The GND pins (pins 18 and 19) and the SUB_GND pin (pin 23) must be short-circuited on the print pattern.

*3. COMIN and FIL pins

These pins are used to connect the filter capacitor. The LV8804 uses the back EMF signal generated when the motor is running to detect the information on the rotor position. The IC determines the timing at which the output block applies current to the motor based on the position information obtained here. Insert a filter capacitor with a capacitance ranging from 1,000pF to 10,000pF (reference value) between the COMIN pin and FIL pin to prevent any motor startup miss-operation that is caused by noise. However, care must be taken since an excessively high capacitance will give rise to deterioration in efficiency and delays in the output power-on timing while the motor is running at high speed. Furthermore, connect the capacitor between the COMIN pin and FIL pin as close as possible in order to avoid the effects of noise from other sources.

*4. CT pin

This pin is used to connect the lock detection capacitor.

The constant-current charging and constant-current discharging circuits incorporated causes locking when the pin voltage reaches 2.5V, and releasing the lock protection when it drops to 0.5V. This pin must be connected to the GND when it is not going to be used.

*5. RF pins

These pins are used to set the current limit.

When the pin voltage exceeds 0.25V, the current is limited, and regeneration mode is established. In the application circuit, this voltage is set in such a way that the current limit will be established at 1A.

The calculation formula is given below.

RF resistance = 0.25V/target current limit value

All the RF pins (pins 24, 26 and 27) must be short-circuited on the print pattern.

*6. SOFTST pin

This pin is used to set the soft start.

By connecting a capacitor between this pin and GND, the motor speed can be increased gradually.

When the pin voltage exceeds 2.5V, the soft start is released, and the LV8804V is switched to normal control.

If the soft start function is not going to be used, connect the pin to the VREG pin.

*7. OSC pin

This pin is used to connect the capacitor for setting the startup frequency.

A capacitor with a capacitance ranging from about 500pF to 2,200pF (reference value) must be connected between this pin and GND.

The OSC pin determines the motor startup frequency, so be sure to connect a capacitor to it.

<How to select the capacitance>

Select a capacitance value that will result in the shortest possible startup time for achieving the target speed and produce minimal variations in the startup time. If the capacitance is too high, variations in the startup time will increase; conversely, if it is too low, the motor may idle. The optimum OSC constant depends on the motor characteristics and startup current, so be sure to recheck them when the type of motor used or circuit specifications are changed.

*8. MINSP pin

This pin is used to input the voltage to set the minimum speed.

The minimum speed can be set by resistor-dividing the VREG voltage (5V) to create a voltage of 1 to 3V, and inputting this voltage to the MINSP pin.

If the minimum speed is not going to be set, the MINSP pin and CTL pin (pin 8) must be short-circuited.

*9. VG, CP, and CPC pins

These pins are used to connect the capacitors to generate the pre-drive voltage and stabilize the pre-drive power supply.

Be sure to connect these capacitors in order to generate the drive voltage for the high-side (upper) output DMOS transistor.

*10. VREG pins

These are the control system power supply pin and regulator output pin, which create the power supply of the control unit. Be sure to connect a capacitor between this pin and GND in order to stabilize control system operation.

Since these pins are used to supply current for control and generate the charge pump voltage, connect a capacitor with a capacitance that is higher than that of the capacitor connected to the charge pump.

Both the VREG pins (pins 3 and 4) must be short-circuited on the print pattern.

- SANYO Semiconductor Co.,Ltd. assumes no responsibility for equipment failures that result from using products at values that exceed, even momentarily, rated values (such as maximum ratings, operating condition ranges, or other parameters) listed in products specifications of any and all SANYO Semiconductor Co.,Ltd. products described or contained herein.
- SANYO Semiconductor Co.,Ltd. strives to supply high-quality high-reliability products, however, any and all semiconductor products fail or malfunction with some probability. It is possible that these probabilistic failures or malfunction could give rise to accidents or events that could endanger human lives, trouble that could give rise to smoke or fire, or accidents that could cause damage to other property. When designing equipment, adopt safety measures so that these kinds of accidents or events cannot occur. Such measures include but are not limited to protective circuits and error prevention circuits for safe design, redundant design, and structural design.
- In the event that any or all SANYO Semiconductor Co.,Ltd. products described or contained herein are controlled under any of applicable local export control laws and regulations, such products may require the export license from the authorities concerned in accordance with the above law.
- No part of this publication may be reproduced or transmitted in any form or by any means, electronic or mechanical, including photocopying and recording, or any information storage or retrieval system, or otherwise, without the prior written consent of SANYO Semiconductor Co.,Ltd.
- Any and all information described or contained herein are subject to change without notice due to product/technology improvement, etc. When designing equipment, refer to the "Delivery Specification" for the SANYO Semiconductor Co.,Ltd. product that you intend to use.
- Information (including circuit diagrams and circuit parameters) herein is for example only; it is not guaranteed for volume production.
- Upon using the technical information or products described herein, neither warranty nor license shall be granted with regard to intellectual property rights or any other rights of SANYO Semiconductor Co.,Ltd. or any third party. SANYO Semiconductor Co.,Ltd. shall not be liable for any claim or suits with regard to a third party's intellectual property rights which has resulted from the use of the technical information and products mentioned above.

This catalog provides information as of March, 2009. Specifications and information herein are subject to change without notice.