

SL1714

QUADRATURE DOWNCONVERTER

The SL1714 is a quadrature downconverter, intended primarily for application in professional and consumer digital satellite tuners.

The device contains all elements necessary, with the exception of external local oscillator tank to form a complete system operating at standard satellite receiver intermediate frequencies. It is intended for use with external carrier recovery.

The device includes a low noise RF input amplifier, a reference VCO with prescaler output buffer and In-phase and Quadrature mixers with baseband buffer amplifiers containing AGC gain control.

The SL1714 is optimised to drive a dual ADC converter such as the VP216.

The SL1714 utilises a standard MP16 plastic package, the SL1714C a power MH16 plastic package.

FEATURES

- Single chip system for wideband quadrature downconversion
- Compatible with all standard high IF frequencies
- Excellent gain and phase match up to 30MHz baseband
- High output referred linearity for low distortion and multi channel application
- Simple low component application
- Fully balanced low radiation design with fully integrated quadrature generation
- High operating input sensitivity
- On-board AGC facility
- On chip oscillator for varactor tuning or SAW resonator operation
- ESD protection (Normal ESD handling procedures should be observed)

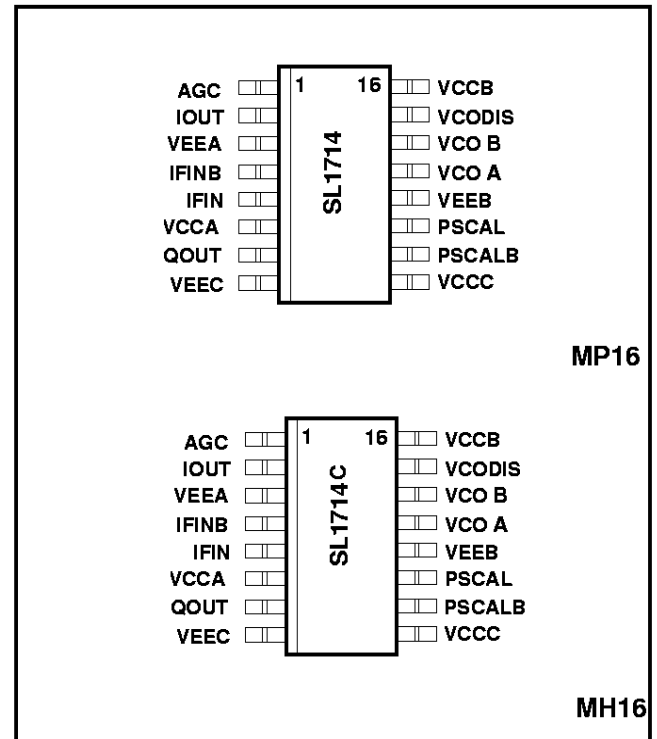

Fig. 1 Pin allocation SL1714

APPLICATIONS

- Satellite receiver systems
- Data communications systems
- Cable systems

ORDERING INFORMATION

- SL1714/KG/MP1S (Sticks)
- SL1714/KG/MP1T (Tape and Reel)
- SL1714C/KG/MH1P (Sticks)
- SL1714C/KG/MH1Q (Tape and Reel)

SL1714

QUICK REFERENCE DATA

Characteristic	Value	Units
Input noise figure, DSB	17	dB
Maximum conversion gain	48	dB
Minimum conversion gain	28	dB
IP3 _{2T} output referred	+8	dBV
Output clip voltage	1.5	V
Gain match up to 30MHz	± 0.5	dB
Phase match up to 15MHz	± 1	deg
Phase match up to 30MHz	± 1.5	deg
Gain flatness up to 30MHz	± 0.5	dB
VCO phase noise, SSB @ 10kHz offset	- 96	dBc/Hz
Prescaler division ratio	32	
Prescaler output swing	1.6	Vp-p

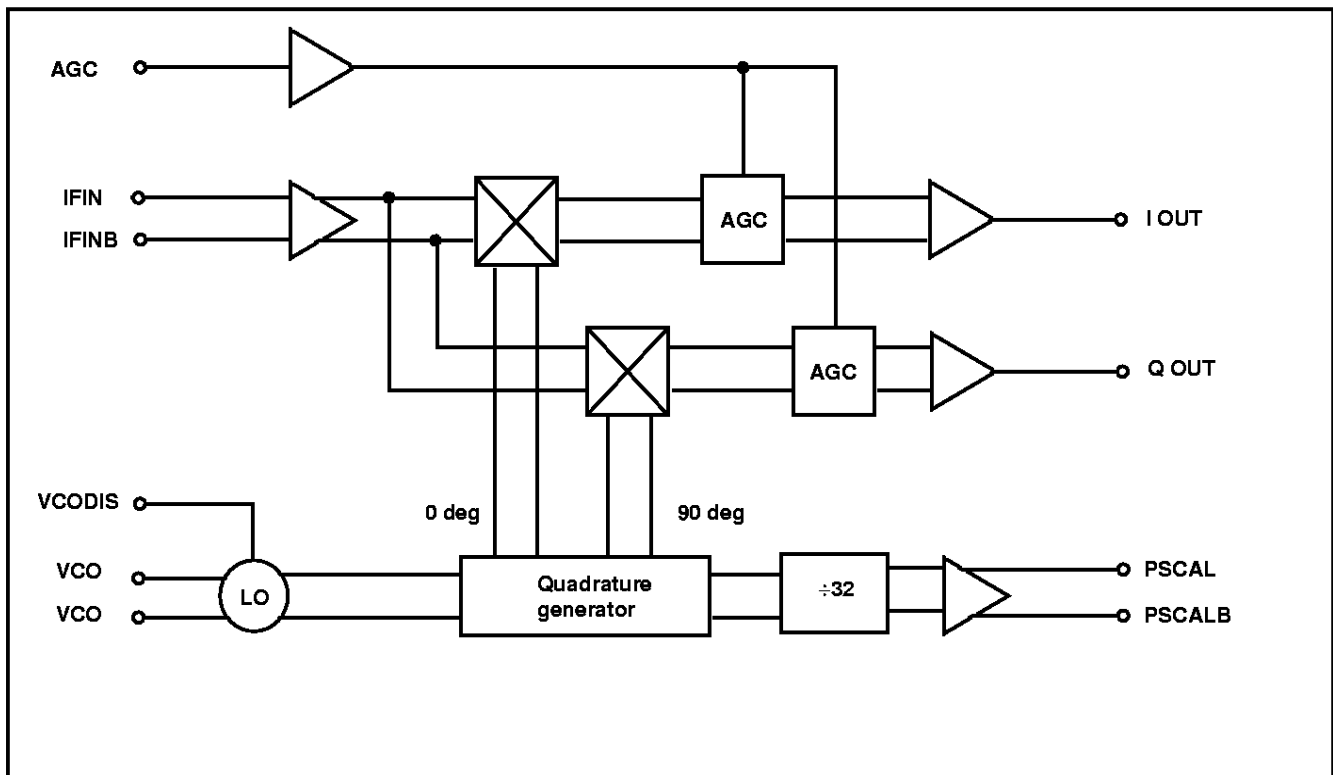

Fig. 2 SL1714 block diagram

FUNCTIONAL DESCRIPTION

The SL1714 is a wideband quadrature downconverter, optimised for application in both professional and consumer digital satellite receiver systems and requiring a minimum external component count. It contains all the elements required for construction of a quadrature demodulator, with the exception of tank circuit for the local oscillator.

A block diagram is shown in Fig. 2.

The SL1714 oscillator can be used with either a varactor tuned tank circuit or with a SAW resonator. Both configurations are described in the Application Notes section of this Data Sheet.

A typical digital satellite tuner application from tuner input to data transport stream is shown in Fig. 13.

In normal applications the second satellite IF frequency of typically 402.75 or 479.5 MHz is fed from the tuner SAW filter to the RF preamplifier, which is optimised for impedance match and signal handling. The amplifier output signal is then split into two balanced channels to drive the In-phase and Quadrature mixers. The typical RF input impedance is shown in Fig. 3.

In-phase and Quadrature LO signals for the mixers are derived from the on board local oscillator, which uses an external varactor tuned resonant network and is optimised for low phase noise. The VCO also drives an on board divide by 32 prescaler whose outputs can be used for driving an external PLL control loop for the VCO, where the PLL loop is contained within the QPSK demodulator, for example the VP305. For optimum performance in the varactor tuned application the VCO should be fully symmetric. The VCO has a disable facility by grounding pin 15, VCODIS; in normal application this pin is pulled to Vcc via a 4K7 resistor.

The mixer outputs are fed to balanced baseband AGC amplifier stages, which provide for a minimum of 12 dB of AGC control. The typical AGC characteristic is shown in Fig. 4.

These amplifiers then feed a low output impedance true differential to single-ended converter output stage. In normal application the output can be either directly AC coupled to the ADC converter such as the VP216, which will generally have a high input impedance, or to drive an anti alias filter. In this later case the maximum load presented to the SL1714 must not exceed a parallel combination of 1K Ω and 15pF. The typical baseband output impedance is contained in Fig. 5.

It is recommended that the device is operated with an output amplitude of 760mV under lock conditions.

Under transient conditions the output should not exceed the clipping voltage.

Input and output interface circuitry is contained in Fig. 6.

The typical key performance numbers at 480 MHz IF, 5V Vcc, 1 K Ω load and 25 deg C ambient are contained in table headed 'QUICK REFERENCE DATA'. With SAWR oscillator application the gain and phase match performance will typically exceed these numbers.

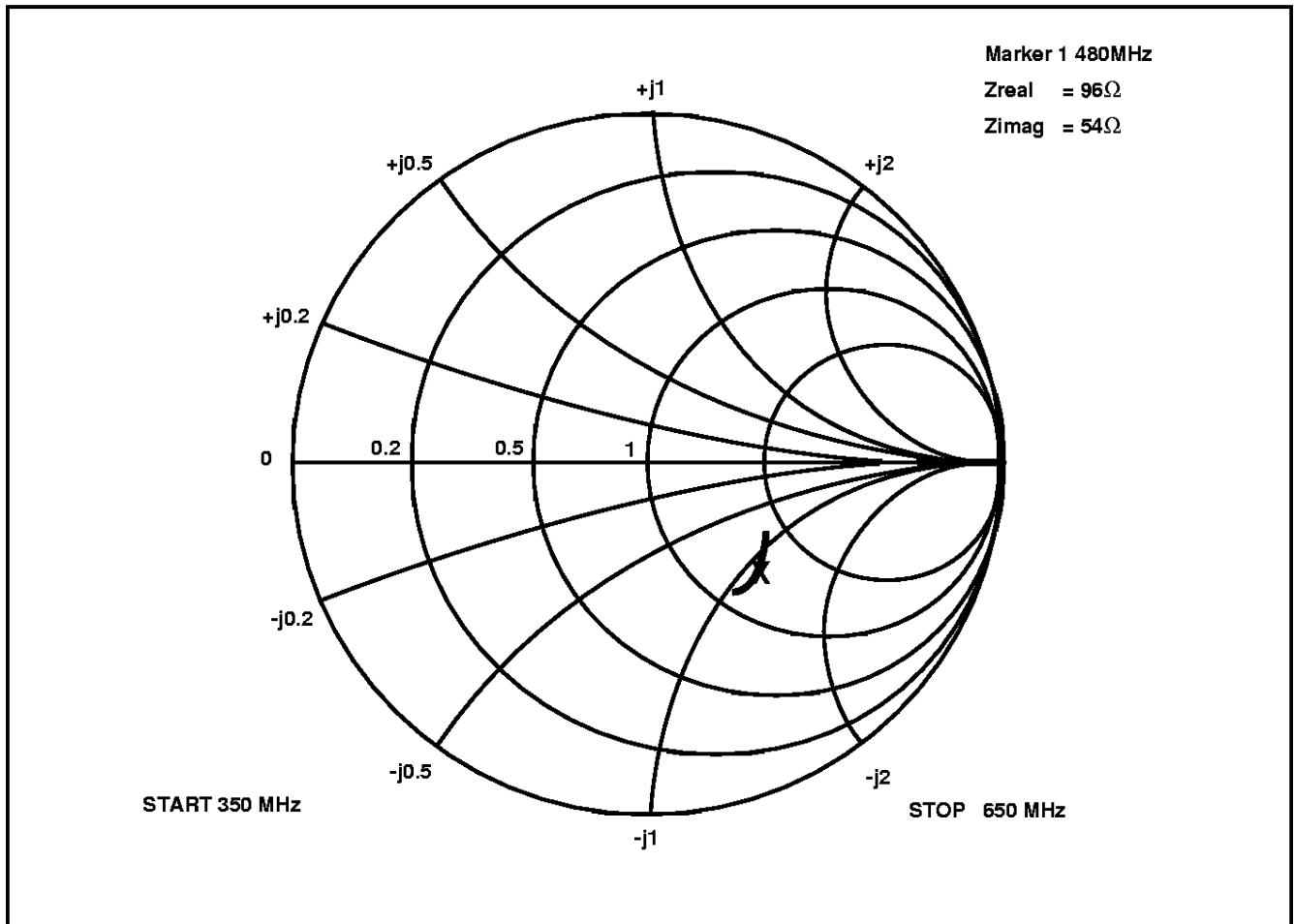

Fig.3 Typical RF input impedance

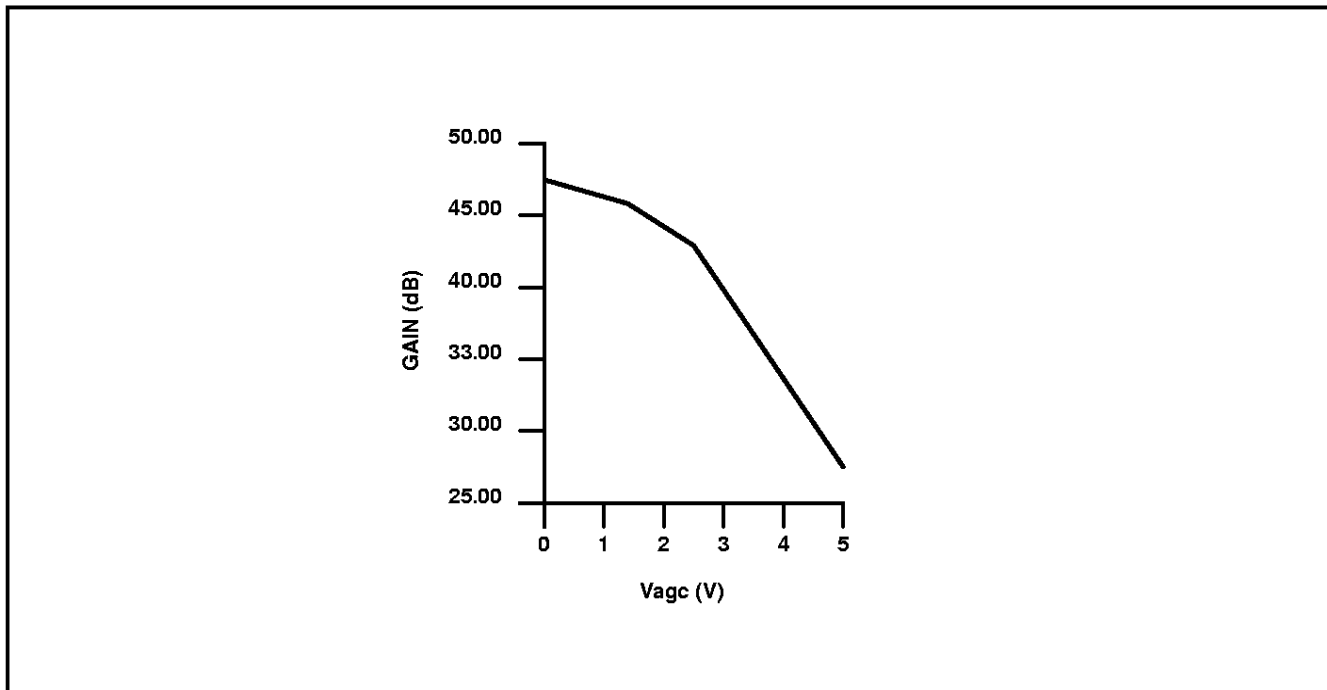

Fig.4 Typical AGC characteristic

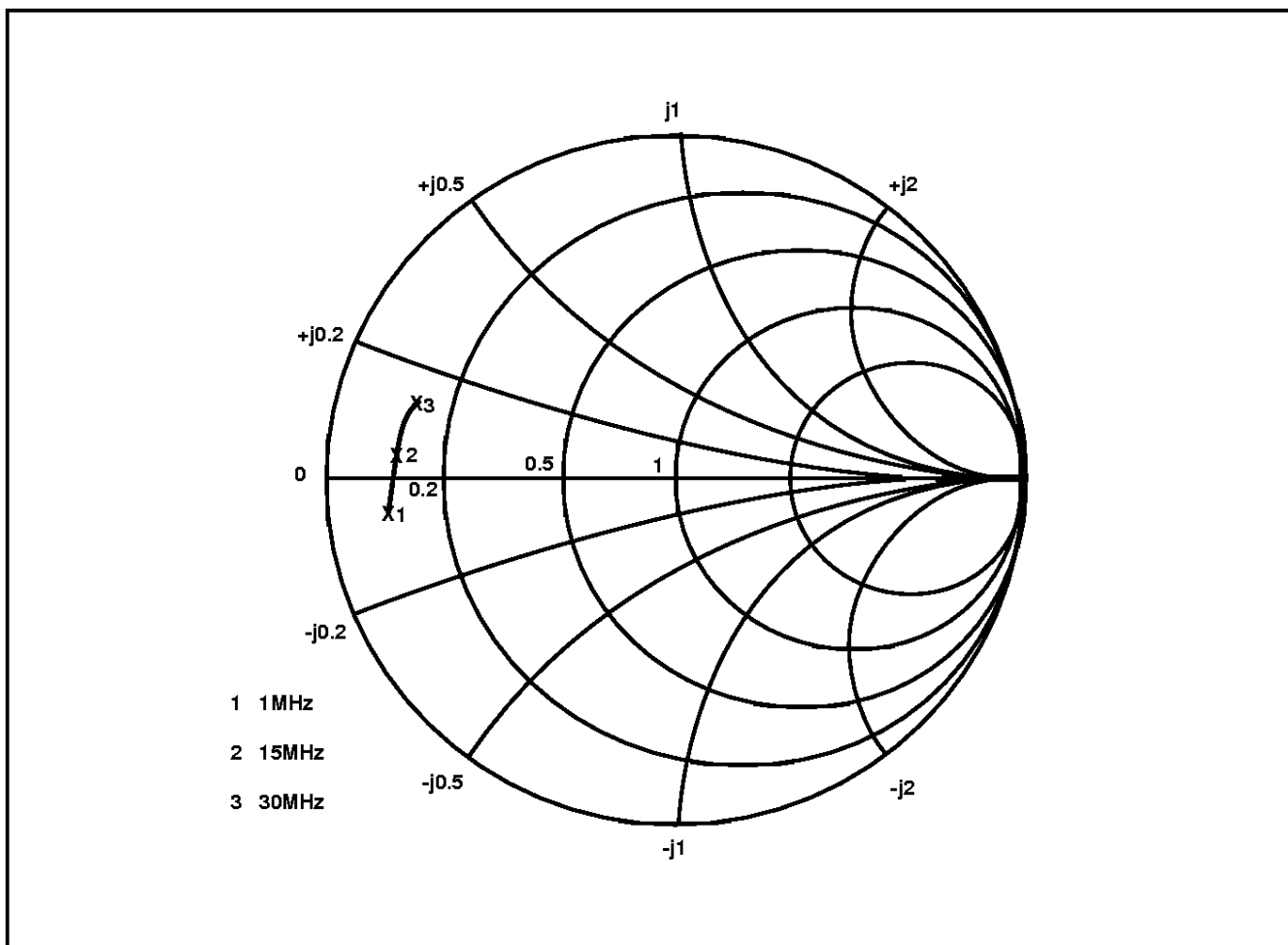

Fig. 5 Typical baseband output impedance

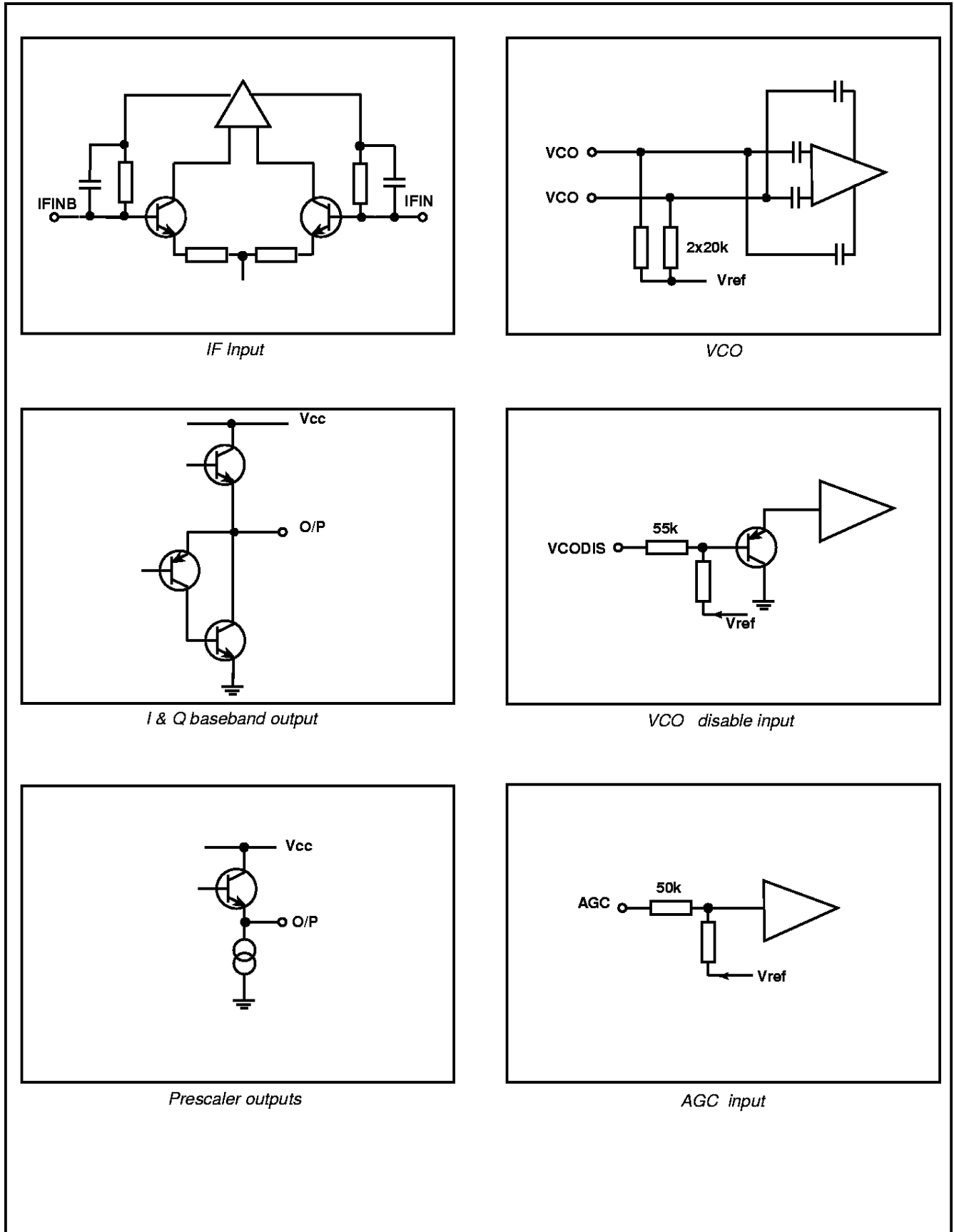

Fig. 6 I/O port peripheral circuitry

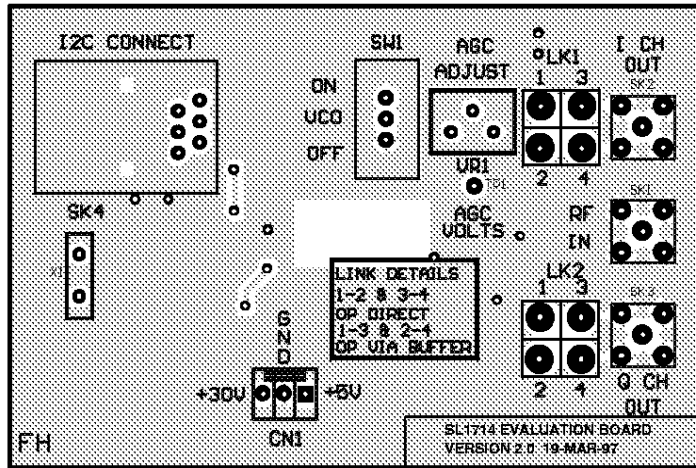

Fig.8

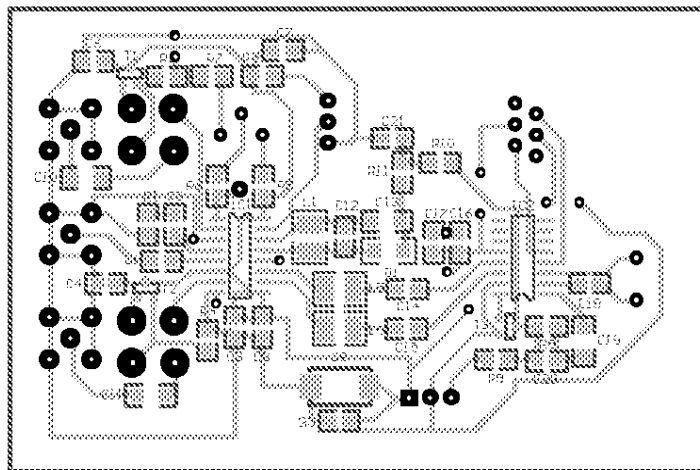

Fig.9

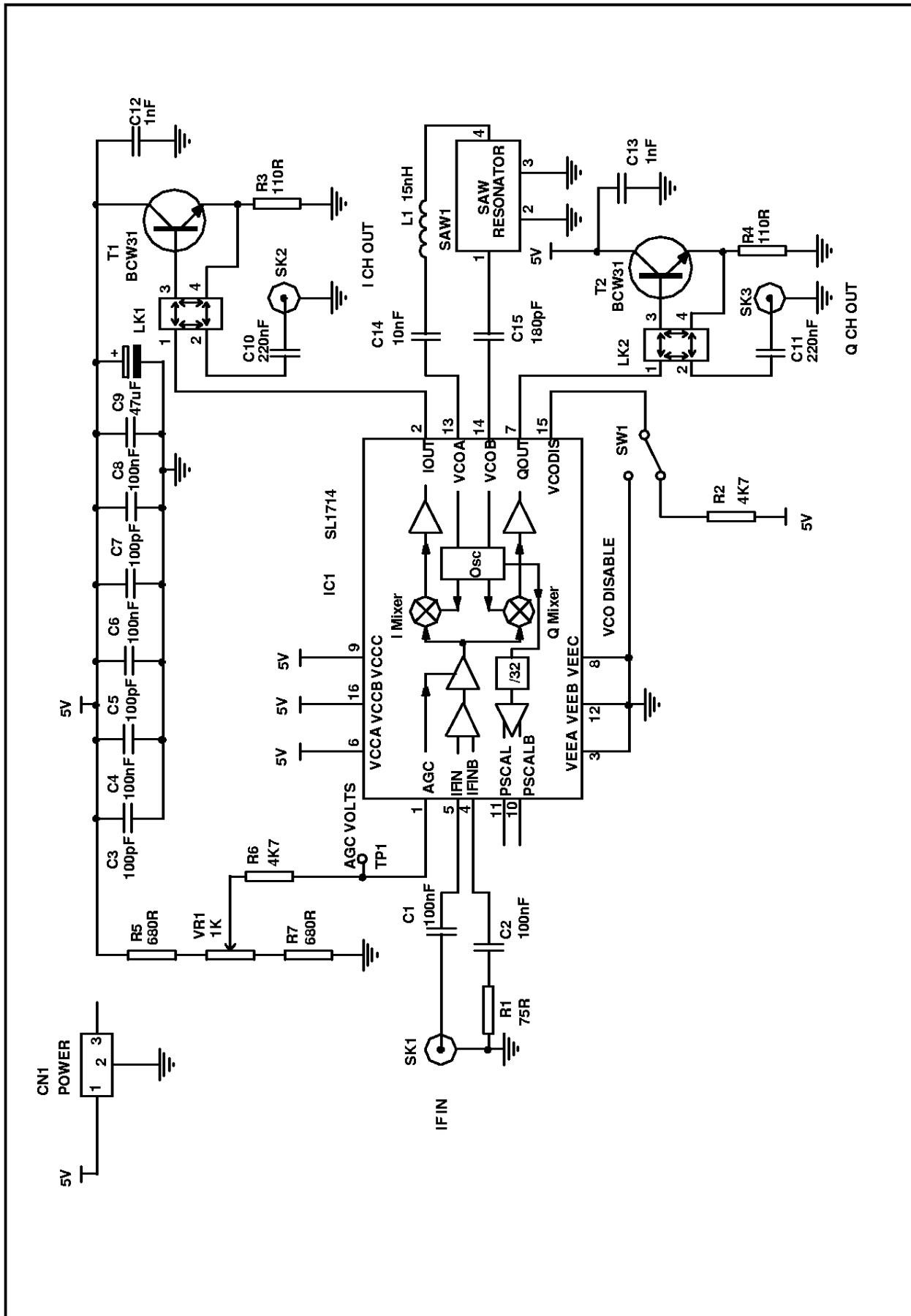

Fig.10. SL1714 I & Q downconverter with SAW resonator

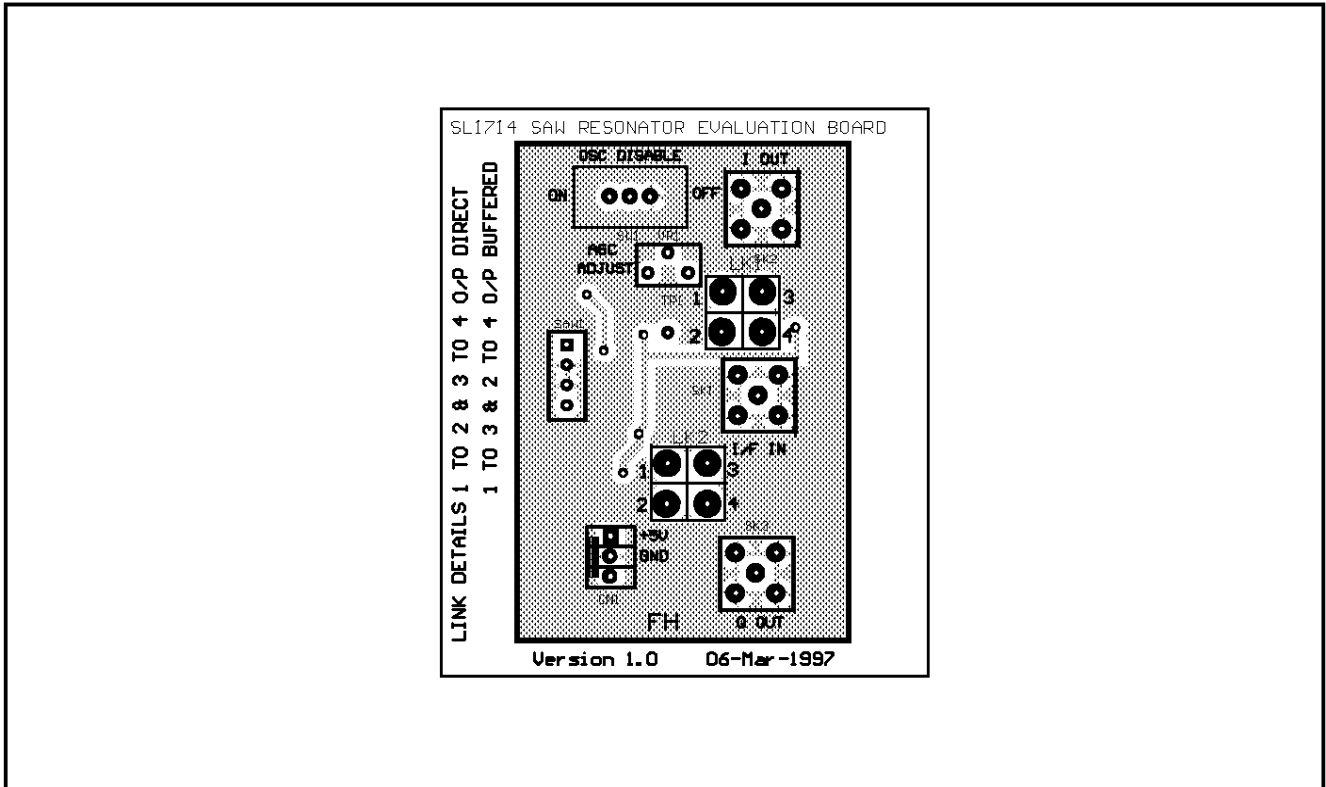

Fig. 11

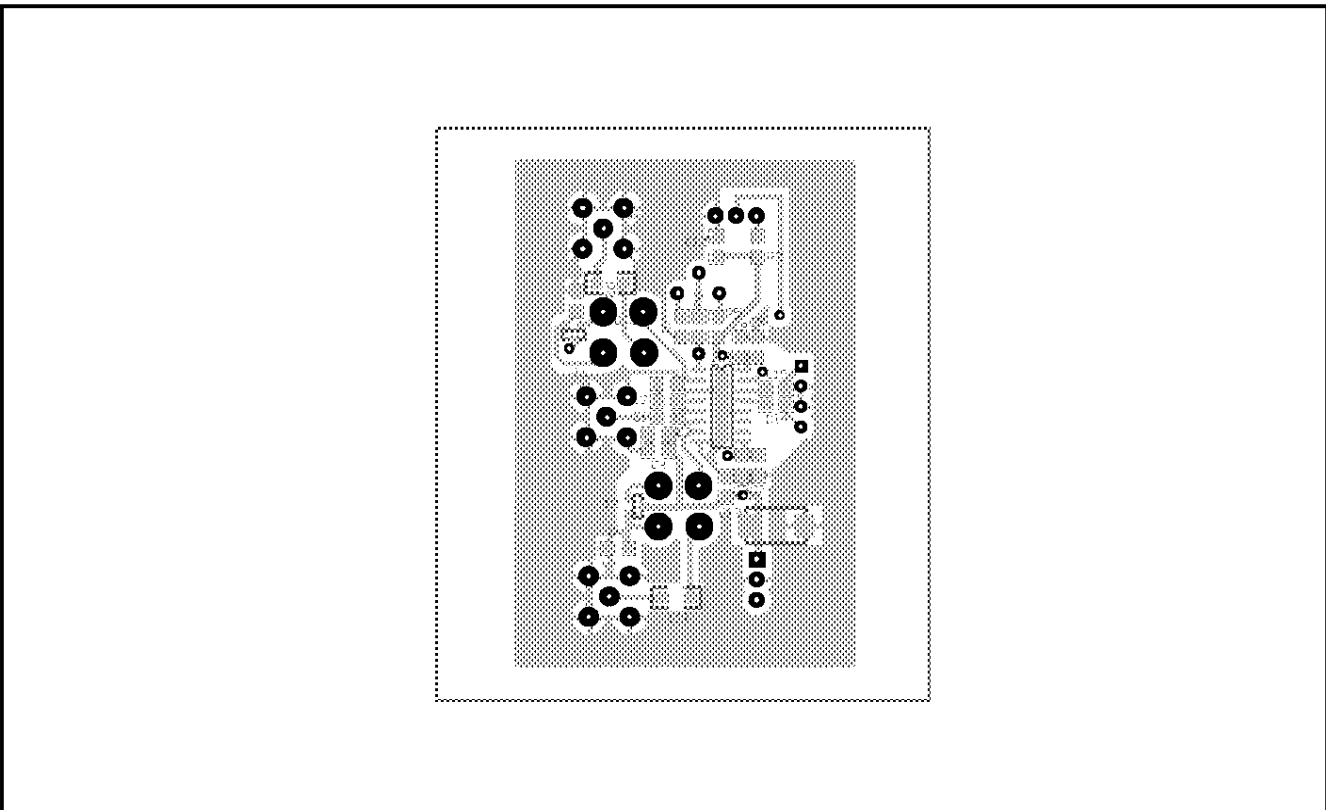

Fig. 12

APPLICATION NOTES

These application notes should be read in conjunction with circuit diagrams contained in Fig. 7 and 10, and a recommended front end tuner solution contained in Fig. 12. These boards have been designed to demonstrate performance and to allow for initial evaluation of the SL1714.

Varactor Tuned Oscillator

Refer to Fig. 7 circuit diagram and Figs. 8 and 9 PCB layout.

This application uses a synthesised VCO with a tuning range of 460 MHz to 500 MHz. The surface mount inductor L1 is 12 nH. The VCO frequency is controlled by the SP5611 synthesiser which is programmed via an I²C bus. The RF input to the synthesiser is from the SL1714 prescaler outputs coupled via RF inductors L3 and L4.

For functional checking the VCO can be tuned by physically shorting the base of transistor T3 to ground and then adjusting the +30 volt supply to tune the VCO. Under these conditions, due to the unlocked state of the LO, the board WILL NOT BE representative of locked gain and phase match or phase noise performance.

In real applications the VCO control voltage will be provided by the QPSK demodulator circuit, such as the VP305. This circuit provides a line voltage to align the reference LO in the SL1714 in both frequency and phase to the centre of the modulation bandwidth, normally 402.75 or 479.5 MHz.

As in all feedback loops the bandwidth of the varactor line must be optimised for the symbol rate of the received modulation.

It is recommended for optimum performance that the VCO application is implemented symmetrically, in presented drive and impedance to the VCO ports, as demonstrated in the evaluation schematic and PCB.

In the recommended application the varactor diodes are referenced to the VCO port DC bias voltages. This limits the minimum tuning voltage on the varactor line to 3V. If lower tuning voltage is required the tank can be AC coupled to the VCO ports by 390pF capacitor and a DC reference voltage for the varactor diodes applied by centre tapping the tank inductors. NB the varactor diodes require a minimum of 1V reverse bias for correct operation.

In real applications the maximum tuning range required for the VCO will be determined by the required lock range of the tuner and the manufacturing tolerance of the tank, assuming the quadrature downconverter section will be alignment free. This tuning range will typically be much smaller than the demonstration board, which will consequently improve the VCO phase noise performance.

This application can be ported direct to real system implementations. Normal good RF practice must be applied to the layout implementation.

Prescaler Outputs (varactor tuned VCO)

The VCO frequency divided by 32 is available at the differential prescaler outputs, pins 10 and 11.

These enable the VCO frequency to be synthesised by a PLL frequency synthesiser; on the demo board an SP5611 is used for this function however in a real application this function will be provided by the QPSK demodulator function contained in for example the VP305.

It is recommended that the prescaler outputs are loaded symmetrically to balance radiation effects.

Saw Resonator Oscillator

Refer to Fig. 10 circuit diagram and Figs 11 and 12 PCB layout.

In the standard application the oscillator uses a varactor diode tuned tank circuit which allows fine tuning of the oscillator frequency via a voltage control line. This control voltage is usually derived from the QPSK/FEC decoder VP305/VP306.

Certain applications do not require this fine tune facility so a fixed frequency application using a SAW resonator has been developed. In this application the frequency of the oscillator is determined by the SAW resonator. The SAW is AC coupled into the VCO pins of the device pins 13 and 14 via 100pF coupling capacitors.

The SAW resonator used in this application is a ;
Murata Part No SAR479.45MB10X200

Prescaler Outputs (SAWR tuned VCO)

The VCO frequency divided by 32 is available at the differential prescaler outputs, pins 10 and 11. Normally these outputs will not be required since the derotation and fine tuning required will be processed by the QPSK demodulator. However these frequencies could be used if required for other system reference frequencies or clocks.

If used it is recommended that the prescaler outputs are loaded symmetrically to balance radiation effects.

VCO Disable

The on-chip oscillator can be disabled by connecting VCODIS, pin 15, to ground and enabled by connecting to Vcc via a 4K7 pull up resistor.

AGC

The AGC facility can be used to control the conversion gain of the SL1714.

On the demonstration boards the conversion gain is adjusted by means of a potentiometer, which is set to 2.5V so giving a conversion gain of 40 dB. The voltage adjustment range for the AGC is approximately 0.5 to 4.5 V.

It is important that the AGC voltage minimum does not give a conversion gain of greater than 44dBs otherwise the channel amplitude match may be degraded. In real applications the AGC can be either set at a fixed control voltage or controlled by means of the AGC control signal from the QPSK demodulator dependant on the overall dynamic range requirement of the tuner and it's gain distribution.

SL1714

I & Q baseband outputs

The SL1714 offers a greatly improved drive capability over the SL1710 and as such is much less sensitive to the load conditions.

It is still important however to carefully balance the loads presented to the SL1714 to ensure no differential gain or phase degradation is introduced by the load circuits, which will also include effects due to track striplines etc.

For demonstration purposes the output is unsuitable for connection via co-axial cables to standard test equipment, where such equipment is normally 50 Ω or highly capacitive.

To overcome this problem the outputs of the SL1714 are therefore buffered through emitter followers which are optimised to drive 50 Ω loads without appreciable degradation in the SL1714 performance. These buffer stages are selectable so enabling the outputs to be loaded directly for interfacing direct with an ADC via a low capacitive link.

In most applications the SL1714 will normally interface direct into the ADC converter such as the VP216, which will present a >1 K Ω low capacitive load.

The output is optimised for typical drive levels of 760 mVp-p and the onset of clipping is typically > 1.5 V p-p.

SL1714 Evaluation Board

This board has been created to show the operation of the SL1714 I/Q downconverter.

It does not attempt to simulate a real system, since in practice the 479.5MHz IF oscillator on the SL1714 (and the 60MHz clock on the subsequent ADC) would be controlled via the baseband IQ demodulator chip such as the VP305 which follows the dual channel ADC. For simplicity, the VCO is locked using GPS SP5611 synthesiser, controlled via an I²C bus.

For full evaluation, 30V and 5V supplies are necessary.

Supplies

The board must be provided with the following supplies:

A) 5V for the SL1714 and SP5611 and 30V for the varactor line.

The supply connector is a 3 pin 0.1" pitch pin header. The centre pin of the connector is GND.

Outputs driven into hard clipping can exhibit amplitude decline. AGC loops should be designed to take account of this.

I²C Bus connections

The board is provided with an RJ11 I²C bus connector which feeds directly to the SP5611 synthesiser.

This connects to a standard 6-way connector cable which is supplied with the I²C/3-wire bus interface box.

Input and Output connections

The board is provided with the following connectors:

- A) IF I/P SMA connector SK1 which is AC coupled to the RF input of the SL1714.
- B) I CH OUT SK2 and Q CH OUT SK3 which provide either a buffered or direct baseband output signal from the SL1714 (depending on which way the links LK1 and LK2 are set). The output buffers should be used when driving 50 Ω test equipment or co-axial lines.

Links and Switches

The board is provided with the following:

VCO DISABLE switch

This disables the VCO of the SL1714. It does NOT power down the chip.

AGC ADJUST potentiometer

The potentiometer sets the AGC input voltage of the SL1714 which controls the gain of the chip. TP1 is provided as a means of monitoring the AGC voltage.

LK1 and LK2

These are links which may be placed either vertically or horizontally to connect the outputs of the SL1714 either directly or via buffers to the SMA output connectors of the board.

If the links are placed vertically 1-2 and 3-4 the outputs are connected directly.

If the links are placed horizontally 1-3 and 2-4 the outputs are connected via buffers.

Programming of Synthesisers

A SP5611 synthesiser is used to set the frequency of the SL1714 VCO (480MHz). Since the SL1714 incorporates a divide by 32 the synthesised frequency that the SP5611 must be programmed to is $480/32=15\text{MHz}$.

Example

a) To program the SL1714 to 480MHz.

I2C Byte	Hex Code
Byte 1 (address)	C2
Byte 2 (programmable divider 8 MSBs)	00
Byte 3 (programmable divider 8 LSBs)	F0
Byte 4 (control data)	CE
Byte 5 (port data)	00

C2 is the address byte (byte 1).

0F00 is the programmable divider information (bytes 2 and 3).

CE is the control data information (byte 4).

****Note** - the programmable divider information should be set to program $480\text{MHz} / 32 = 15\text{MHz}$ since the SL1714 provides a divide by 32 prescaler output rather than the VCO carrier frequency.

It is not possible to program the VCO to 479.5MHz when using a 7.8125kHz phase comparator frequency. The minimum step size is $7.8125\text{kHz} \times 8$ (RF prescaler inside SP5611) $\times 32$ (SL1714 output prescaler) = 2MHz.

If the reference divider is set to 1024 mode (3.90625kHz phase comparator frequency), the minimum step size will be 1MHz.

This may be achieved by programming the control byte to CC and modifying the programmable divider information for the new step size.

SL1714 Operation

The SL1714 will mix an IF input with its own local oscillator. This is controlled as above via a SP5611 synthesiser.

Normally the VCO will be set to the same frequency as the IF input, and the signal mixed directly down to baseband.

Alternatively, a CW RF source may be fed into the input of the SL1714 which is deliberately offset from the VCO. By varying the offset from 0-20MHz and monitoring the I and Q channel baseband outputs, the flatness response of the chip/output filter can be measured.

The SL1714 oscillator may also be disabled by setting the ON-VCO-OFF switch to the OFF position.

An AGC voltage adjust pot marked AGC ADJUST is provided, together with a test point.

Measurement of Gain and Phase Match.

a) Synthesise the required frequency (480MHz is used in the example above).

b) Connect an RF signal generator to the input.

c) Input a signal which should give an output of approx 0dBm (0.707V p-p), in combination with the appropriate AGC setting.

d) Connect a vector voltmeter to the BUFFERED outputs when using 50Ω inputs. When using high impedance probes, the direct outputs may be used. Selection of outputs is via the on board U links.

e) CALIBRATE the vector voltmeter and the leads to be used.

The calibration should be performed at the chosen baseband frequency and level for maximum accuracy.

f) Vary the RF input frequency either side of the LO and note the relative I and Q gain and phase reading.

If you experience any difficulties with this board, or require further help, please contact *Robert Marsh* on 01793 518234 or *Fred Herman* on 01793 518423

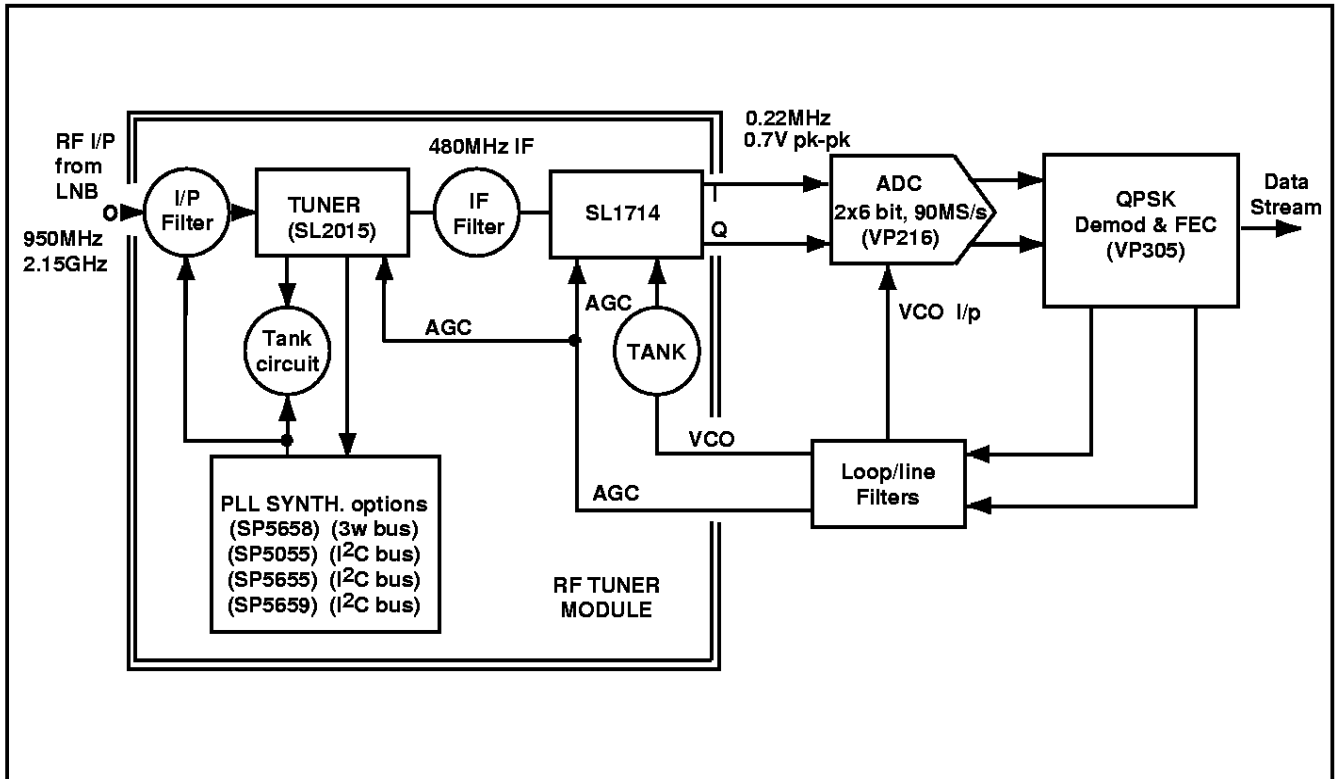

Fig.13 Example digital front end architecture

Note: All ICs shown in Fig. 12 are available from GEC Plessey Semiconductors.

ELECTRICAL CHARACTERISTICS

Test conditions (unless otherwise stated)

T_{amb} = see note 7, V_{EE} = 0V, V_{CC} = 4.75 to 5.25 V, F_{if} = 479.5 MHz, IF bandwidth \pm 30 MHz, output amplitude -11dBV

These characteristics are guaranteed by either production test or design. They apply within the specified ambient temperature and supply voltage unless otherwise stated.

Characteristic	Pin	Min	Typ	Max	Units	Conditions
Supply voltage	6,9,16	4.75		5.25	V	
Supply current	6,9,16		109	125	mA	
IF input operating frequency (1)	4, 5	350		550	MHz	
IF input impedance	4, 5		75		Ω	Over specified frequency operating range, see Fig. 6.
Input return loss	4, 5	12			dB	Over specified frequency operating range, see Fig. 6.
Input noise figure, DSB	4, 5		17	19	dB	Maximum gain setting
Variation in NF with gain setting				1	dB/dB	
VCO operation range		350		550	MHz	Centre frequency and tuning range determined by application.
VCO phase noise, SSB @ 10kHz offset			-96	-85	dBc/Hz	Varactor tuned, determined by application. Free running Uncompensated
VCO Vcc sensitivity				2E3	ppm/V	
VCO temperature stability				100	ppm/ $^{\circ}$ C	
Prescaler output swing	10, 11	1.2	1.5		Vp-p	
Prescaler output duty cycle	10, 11	40	50	60	%	
AGC						
Gain, V _{agc} = +2.5V			40		dB	For any gain setting 0V to 5V See Fig. 4 See Fig. 4
Temp sstability of gain	1			\pm 1	dB	
Gain, V _{agc} = +0.5V	1	44			dB	
Gain, V _{agc} = +V _{CC} -0.5V	1			32	dB	
AGC range			18		dB	
I Q gain match			\pm 0.5	\pm 1	dB	See Note 3.
I Q phase match			\pm 1	\pm 2	deg	See Note 4.
I Q phase match			\pm 1.5	TBA	deg	See Note 5.
I & Q channel in band ripple			\pm 0.3	\pm 1	dB	see Note 3.
I & Q channel in band ripple			\pm 0.5	\pm 1	dB	See Note 4.
I Q crosstalk			-29	-20	dB	See Note 2 and 4 for derivation of cross modulation

ELECTRICAL CHARACTERISTICS (continued)

Test conditions (unless otherwise stated)

T_{amb} = See note 7. V_{ee} = 0V, V_{cc} = 4.75 to 5.25 V, F_{if} = 479.5 MHz, IF bandwidth \pm 30 MHz, output amplitude -11dBV

These characteristics are guaranteed by either production test or design. They apply within the specified ambient temperature and supply voltage unless otherwise stated.

Characteristic	Pin	Min	Typ	Max	Units	Conditions
I & Q baseband output impedance	2,7		8	20	Ω	See note (5), and Fig. 5.
I & Q baseband output recommended level	2, 7		-11		dBV	See note(8)
I & Q baseband output clipping level	2, 7	1.5			Vp-p	See note(6)
IP3 _{2T} output referred		+3	+9		dBV	2 input carriers at -39 dBV within IF bandwidth of \pm 30MHz AGC set to give composite output of -11 dBV, IM3 tone within baseband bandwidth
IM3 _{2T} output referred				-40	dBc	2 input carriers within IF bandwidth of \pm 30MHz, AGC set to give composite output of -11 dBV, IM3 tone within baseband bandwidth
All prescaler and other spurs in I & Q baseband output.				-30	dBc	0.1 - 100MHz, referred to output amplitude of - 11 dBV.
Power supply rejection		20			dBc	Attenuation Vcc to I & Q outputs, over 0-500KHz

- Notes:
- Performance not guaranteed over full specified IF input operating range.
 - I Q crosstalk is determined from the gain and phase match by the following formula.
Crosstalk = $20 \cdot \text{Log} (\tan(\text{phase error} + \text{Atan} (1 + \text{amplitude imbalance}) - 45^\circ))$.
 - Over specified gain dynamic range, 1K Ω and 15pF load up to 30MHz baseband.
 - Over specified gain dynamic range, 1K Ω and 15pF load up to 15MHz baseband.
 - Over specified gain dynamic range, 1K Ω and 15pF load up to 30MHz baseband.
 - The device should not be operated beyond the point of output clipping since gain match may be compromised.
 - * Operating temperature range for the SL1714 is 0°C to 70°C. This applies to applications featuring a double sided copper board. For other applications not using such a board, the maximum operating temperature may be reduced. Operating temperature range for the SL1714C is 0° to 85°C.
 - Operation above the recommended IQ output level may result in outputs with harmonic performance degraded.

ABSOLUTE MAXIMUM RATINGS

All voltages are referred to Vee at 0V

Characteristics	Min	Max	Units	Conditions
Supply voltage, Vcc	-0.3	7	V	
IFFIN & IFINB input voltage		2.5	Vp-p	
IFIN & IFINB input DC offset	-0.3	Vcc+0.3	V	
IOUT & QOUT DC offset	-0.3	Vcc+0.3	V	
AGC DC offset	-0.3	Vcc+0.3	V	
VCO1 & 2 DC offset	-0.3	Vcc+0.3	V	
VCODDIS DC offset	-0.3	Vcc+0.3	V	
PSCAL & PSCALB DC offset	-0.3	Vcc+0.3		
Storage temperature	-55	150	°C	
Junction temperature		125	°C	
MP16 package thermal resistance chip to Ambient		81	°C/W	
MH16 package thermal resistance chip to Ambient		TBA	°C/W	
MP16 package thermal resistance chip to case		28	°C/W	
MH16 package thermal resistance chip to Ambient		TBA	°C/W	
Power consumption at 5.25V		656	mW	
ESD protection	3		kV	Mil std 883 latest revision method 3015 cat 1

SL1714

PACKAGE DETAILS

Dimensions are shown thus: mm (in). For further package information, please contact your local Customer Service Centre.

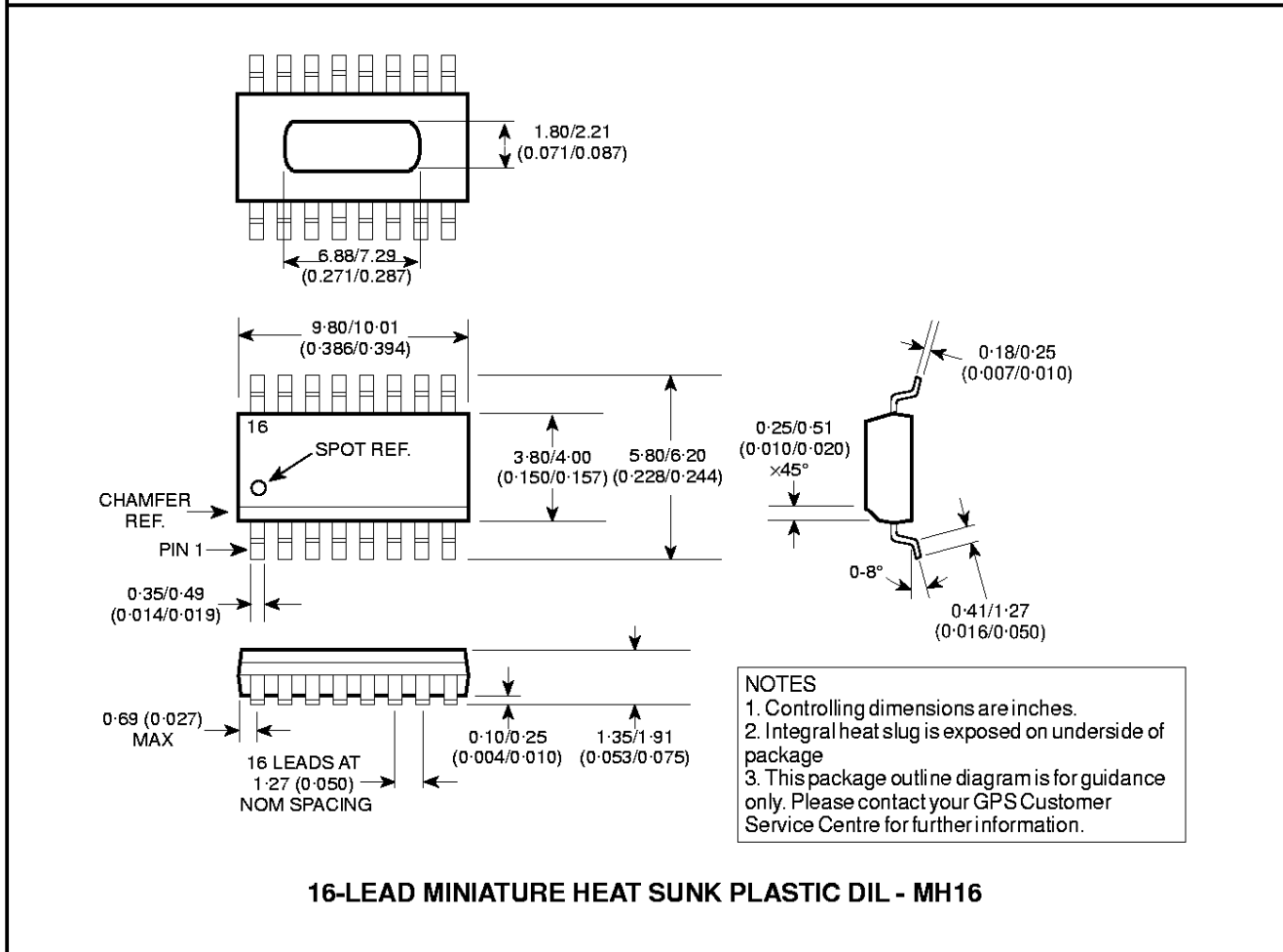
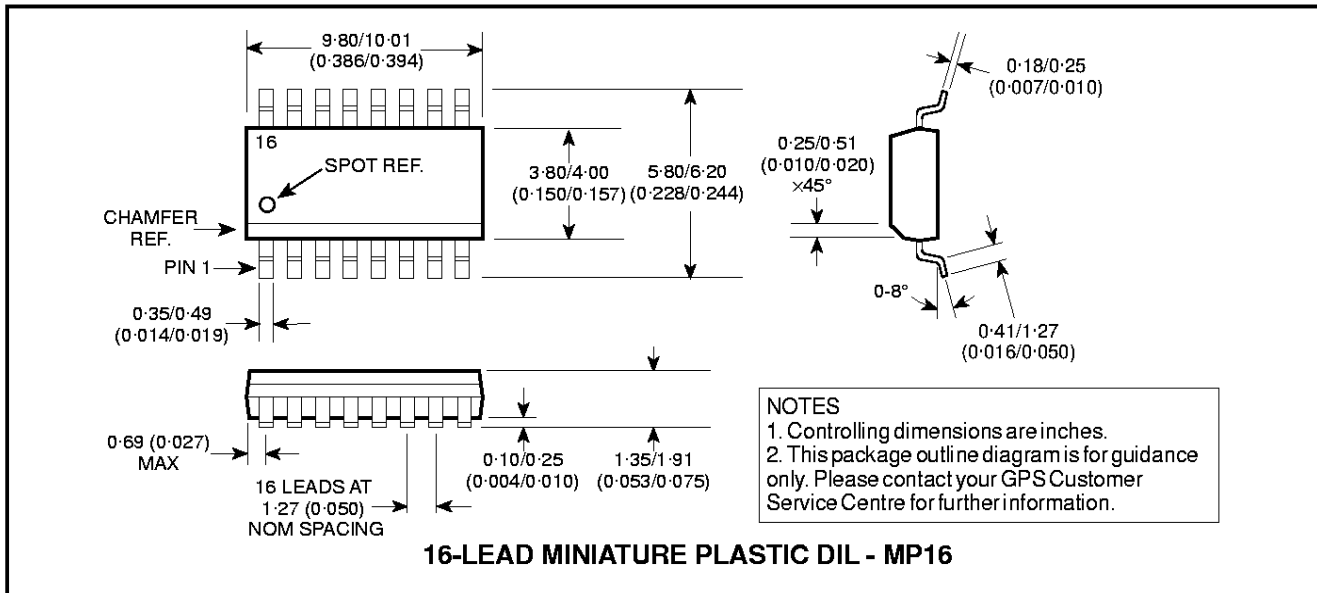



HEADQUARTERS OPERATIONS
GEC PLESSEY SEMICONDUCTORS
Cheney Manor, Swindon,
Wiltshire SN2 2QW, United Kingdom.
Tel: (01793) 518000
Fax: (01793) 518411

GEC PLESSEY SEMICONDUCTORS
1500 Green Hills Road,
Scotts Valley, California 95066-4922,
United States of America.
Tel: (408) 438 2900
Fax: (408) 438 5576/6231

Internet: <http://www.gpsemi.com>

CUSTOMER SERVICE CENTRES

- **FRANCE & BENELUX** Les Ulis Cedex Tel: (1) 69 18 90 00 Fax : (1) 64 46 06 07
- **GERMANY** Munich Tel: (089) 3609 06-0 Fax : (089) 3609 06-55
- **ITALY** Milan Tel: (02) 6607151 Fax: (02) 66040993
- **JAPAN** Tokyo Tel: (03) 5276-5501 Fax: (03) 5276-5510
- **KOREA** Seoul Tel: (2) 5668141 Fax: (2) 5697933
- **NORTH AMERICA** Scotts Valley, USA Tel (408) 438 2900 Fax: (408) 438 5576/6231.
- **SOUTH EAST ASIA** Singapore Tel: (65) 3827708 Fax: (65) 3828872
- **SWEDEN** Stockholm Tel: 46 8 702 97 70 Fax: 46 8 640 47 36
- **TAIWAN, ROC** Taipei Tel: 886 2 5461260. Fax: 886 2 7190260
- **UK, EIRE, DENMARK, FINLAND & NORWAY**
Swindon Tel: (01793) 726666. Fax : (01793) 518582

These are supported by Agents and Distributors in major countries world-wide.

© GEC Plessey Semiconductors 1997 Publication No. DS4619 Issue No. 1.7 November 1997
TECHNICAL DOCUMENTATION - NOT FOR RESALE. PRINTED IN UNITED KINGDOM.

This publication is issued to provide information only which (unless agreed by the Company in writing) may not be used, applied or reproduced for any purpose nor form part of any order or contract nor to be regarded as a representation relating to the products or services concerned. No warranty or guarantee express or implied is made regarding the capability, performance or suitability of any product or service. The Company reserves the right to alter without prior notice the specification, design or price of any product or service. Information concerning possible methods of use is provided as a guide only and does not constitute any guarantee that such methods of use will be satisfactory in a specific piece of equipment. It is the user's responsibility to fully determine the performance and suitability of any equipment using such information and to ensure that any publication or data used is up to date and has not been superseded. These products are not suitable for use in any medical products whose failure to perform may result in significant injury or death to the user. All products and materials are sold and services provided subject to the Company's conditions of sale, which are available on request.

All brand names and product names used in this publication are trademarks, registered trademarks or trade names of their respective owners.