

HCSL TYPE SHO-53

- 5×3.2 mm Miniature Package
- 2.5 V, 3.3 V Supply Voltage
- *Non Multiplied*
- Stability up to ±25 ppm
- HCSL(High speed Current Steering Logic) Output
- Tri-state Function Available

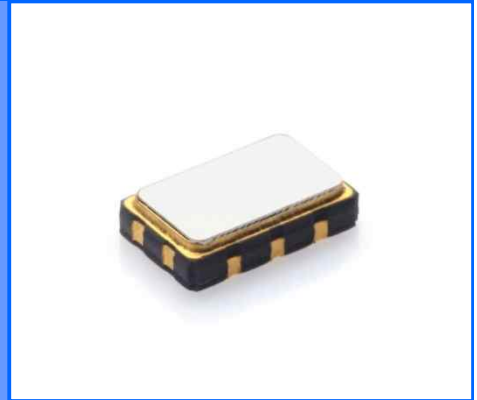

■ ELECTRICAL SPECIFICATIONS

ITEM	Value	Remarks
Output Logic Type	HCSL	HCSL XO
Frequency Range	100.000 MHz, 125.000 MHz	Standard Frequency
Supply Voltage(V _{DD})	2.5 V _{DC} ±5 %, 3.3 V _{DC} ±5 %	
Operating Temperature Range	-20 to +70 °C, -40 to +85 °C	
Storage Temperature Range	-55 to +125 °C	
Frequency Stability	±25 ppm, ±50 ppm Max.	Over operating Temperature range
Input Current	60 mA Max.	
Output Voltage Logic High(V _{OH})	0.580 V Min. 0.850 V Max.	
Output Voltage Logic Low(V _{OL})	-0.150 V Min. 0.150 V Max.	
Rise / Fall Time	0.3 ns Typ., 0.7 ns Max.	Measured over 20 % to 80 % of waveform
Duty Cycle	45 to 55 %, 40 to 60 %	Measured at 50 % of waveform
Start-up Time	10 ms Max.	
Output Load Condition(HCSL)	50 Ω	Between Output and Ground
Output Enable Function (V _{IH} and V _{IL})	70 % of V _{DD} min. to Enable Output 30 % of V _{DD} max. to Disable Output	High Impedance
RMS Phase Jitter	1 ps Max.	BW : 12 kHz to 20 MHz
Frequency Aging	±3 ppm Max.	25 °C, First year

■ MECHANICAL DIMENSIONS (mm)

■ LAND PATTERN (mm)

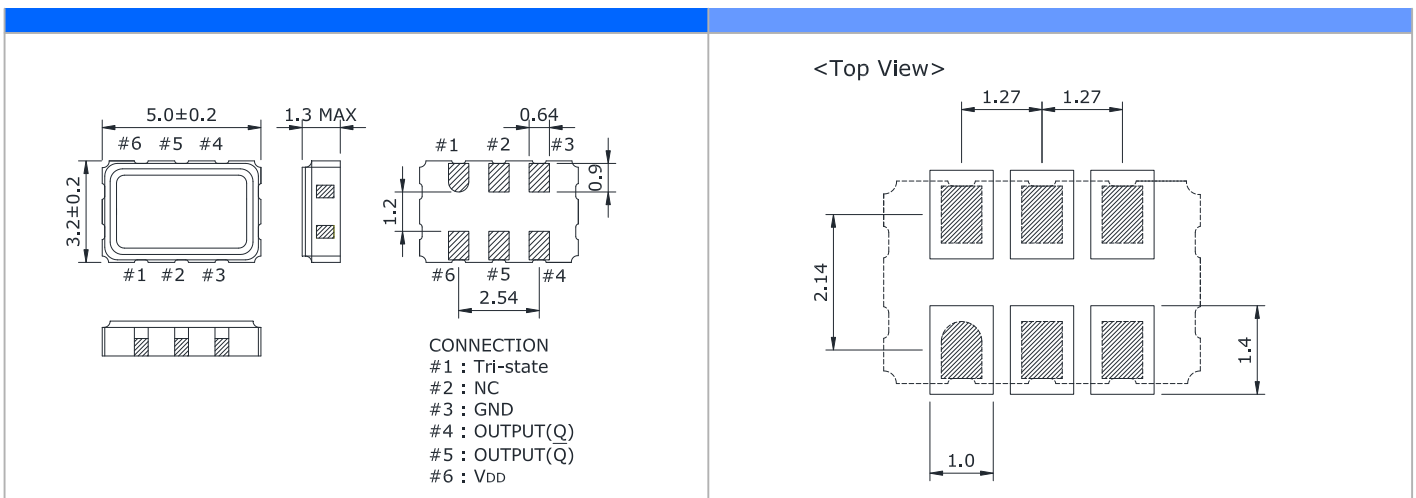

■ PART NUMBERING GUIDE

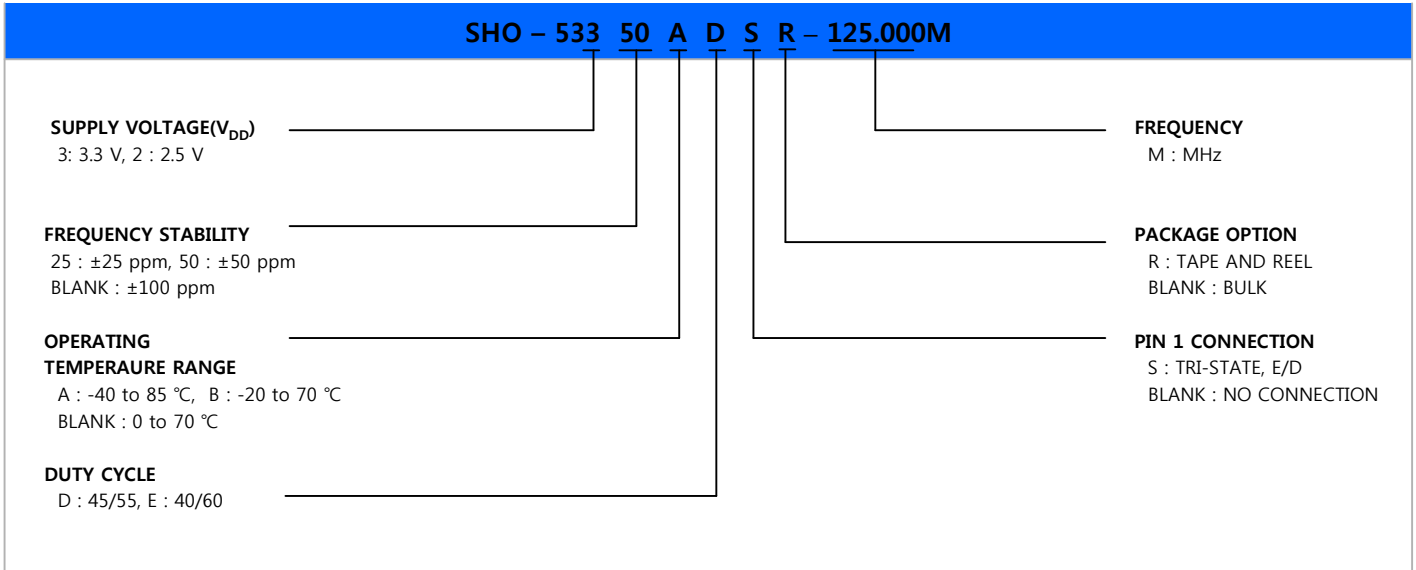

■ TEST CIRCUIT (HCSL)

■ WAVEFORM (HCSL)

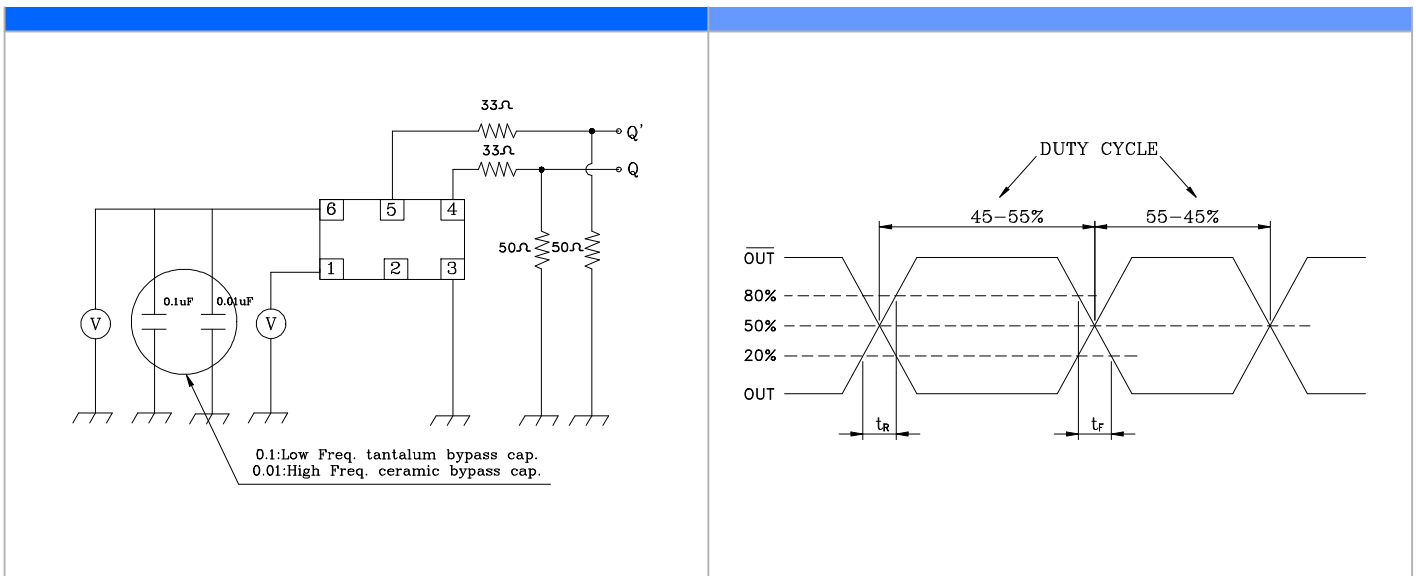

■ ENVIRONMENTAL & MECHANICAL SPECIFICATIONS

Temperature Cycling	MIL-STD-883, Method 1010, Condition B
Fine Leak Test	MIL-STD-883, Method 1014, Condition A
Gross Leak Test	MIL-STD-883, Method 1014, Condition C
Mechanical Shock	MIL-STD-883, Method 2002, Condition B
Vibration	MIL-STD-883, Method 2007, Condition A
Moisture Resistance	MIL-STD-883, Method 1004
Moisture Sensitivity	J-STD-020, MSL 1
Resistance to Soldering Heat	MIL-STD-202, Method 210, Condition K
Solderability	MIL-STD-883, Method 2003

REFLOW PROFILE

MARKING GUIDE

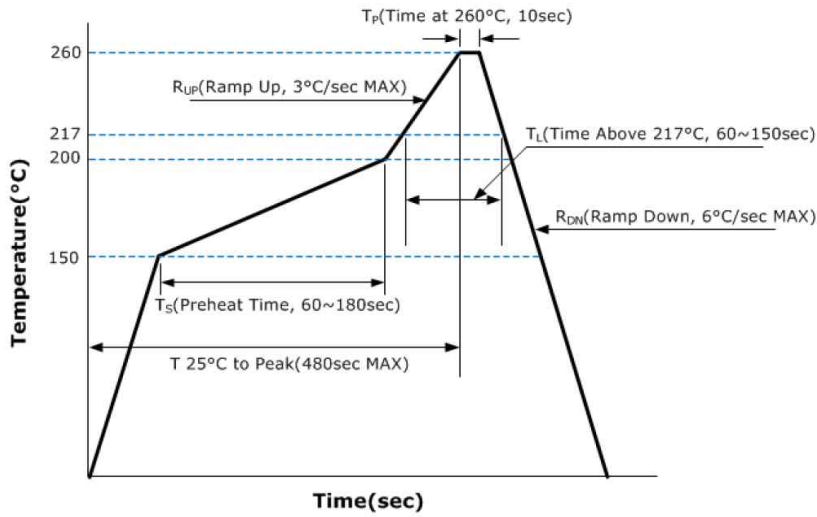

Frequency in MHz

LINE 1 : XXX.XXX

LINE 2 : ● SHO YY WW

Model Name

Year

Week

TAPE AND REEL DIMENSIONS

MAT'L : P.S
 COLOR : WHITE&BLACK
 REFERENCE R=0.2

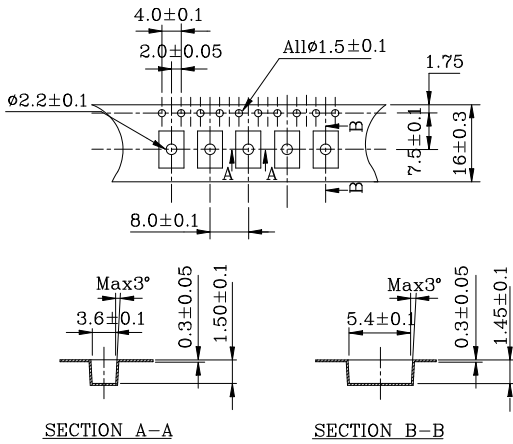

MAT'L : P.S
 COLOR : WHITE&BLACK

