

**66252**

**6 PIN LCC, HERMETICALLY SEALED,  
SINGLE CHANNEL OPTOCOUPLER  
(Electrically Similar To 6N140)**



06/07/2017

**Features:**

- High current transfer ratio: 1000% typical
- 1000 Vdc isolation test voltage
- Low input current requirement: 0.5 mA
- Low power consumption
- High radiation immunity
- Faraday shield to provide high common mode rejection

**Applications:**

- Military and space
- High reliability systems
- Voltage level shifting
- Isolated receiver input
- Communication systems
- Medical systems

**DESCRIPTION**

The **66252** single channel optocoupler consists of an LED optically coupled to a high gain photon detector. This unique device provides high CTR and low leakage currents over the full military temperature range (-55°C to +125°C). The 66252 is in a 6 pin LCC hermetically sealed package and is available in standard and screened versions or tested to customer specifications.

**ABSOLUTE MAXIMUM RATINGS**

Peak Forward Input Current (<1ms duration).....	20 mA
Average Forward Input Current (Note 1).....	10 mA
Reverse Input Voltage .....	5 V
Supply Voltage - V <sub>CC</sub> (Note 2) .....	-0.5 to 20 V
Output Current - I <sub>O</sub> .....	40 mA
Output Power Dissipation (Note 3).....	50 mW
Output Voltage - V <sub>O</sub> (Note 2) .....	-0.5 to 20 V
Storage Temperature.....	-65°C to +150°C
Operating Free-Air Temperature Range .....	-55°C to +125°C
Lead Solder Temperature (10 seconds, 1/16" below seating plane).....	260°C

Notes:

1. Derate I<sub>F</sub> at a rate of 0.33 mA/°C above 110°C.
2. Pin 3 should be the most negative voltage at the detector side. The lowest total I<sub>OH</sub> over temperature is developed by keeping V<sub>CC</sub> as low as possible, but greater than 2.0 V.
3. Collector output power plus supply power is total output power. Derate at rate of 0.5 mW/°C above 25°C.

**Package Dimensions**

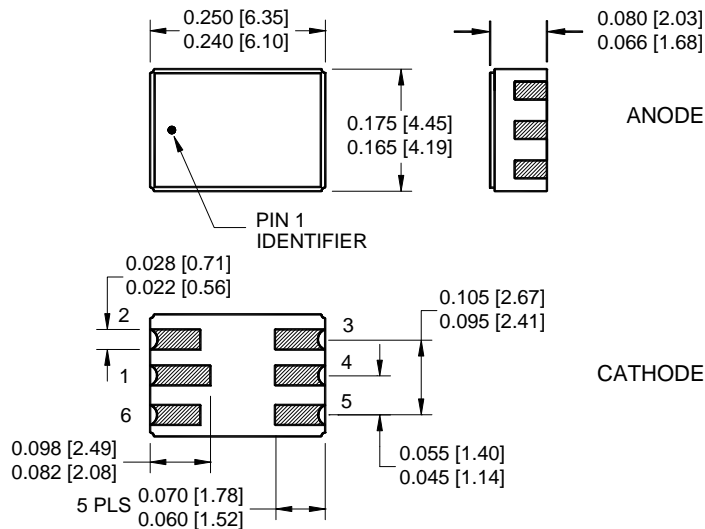

**Schematic Diagram**

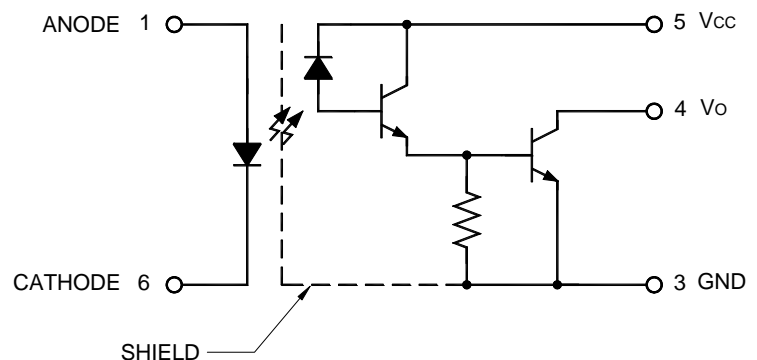

ALL DIMENSIONS ARE IN INCHES [MILLIMETERS]

Micropac Industries cannot assume any responsibility for any circuits shown or represent that they are free from patent infringement. Micropac reserves the right to make changes at any time in order to improve design and to supply the best product possible.

66252

6 PIN LCC, HERMETICALLY SEALED, SINGLE CHANNEL OPTOCOUPLER (Electrically Similar To 6N140)

06/07/2017

**ELECTRICAL CHARACTERISTICS**T<sub>a</sub> = -55°C to 125°C unless otherwise specified.

PARAMETER	SYMBOL	MIN	TYP	MAX	UNITS	TEST CONDITIONS	NOTE
Current Transfer Ratio	CTR	300	1000		%	I <sub>F</sub> = 0.5 mA, V <sub>O</sub> = 0.4 V, V <sub>CC</sub> = 4.5 V I <sub>F</sub> = 1.6 mA, V <sub>O</sub> = 0.4 V, V <sub>CC</sub> = 4.5 V I <sub>F</sub> = 5.0 mA, V <sub>O</sub> = 0.4 V, V <sub>CC</sub> = 4.5 V	1
Logic Low Output Voltage	V <sub>OL</sub>		0.1	0.4	V	I <sub>F</sub> = 0.5 mA, I <sub>OL</sub> = 1.5 mA, V <sub>CC</sub> = 4.5 V I <sub>F</sub> = 5.0 mA, I <sub>OL</sub> = 10 mA, V <sub>CC</sub> = 4.5 V	
Logic High Output Current	I <sub>OH</sub>		0.005	250	μA	I <sub>F</sub> = 2 μA, V <sub>O</sub> = V <sub>CC</sub> = 18 V	
Logic High Supply Current	I <sub>CCH</sub>		0.010	40	μA	I <sub>F</sub> = 0 mA, V <sub>CC</sub> = 18 V	
Low Level Supply Current	I <sub>CCL</sub>		0.8	4	mA	I <sub>F</sub> = 1.6 mA, V <sub>CC</sub> = 18 V	
Input Forward Voltage	V <sub>F</sub>		1.4	1.7	V	I <sub>F</sub> = 1.6 mA	
Input Reverse Breakdown Voltage	BV <sub>R</sub>	5			V	I <sub>R</sub> = 10 μA	
Input-Output Insulation Leakage Current	I <sub>I-O</sub>			0.5	μA	V <sub>I-O</sub> = 1000 Vdc, Relative Humidity = 45% t <sub>a</sub> = 25°C, t = 1 s	2
Propagation Delay Time To High Output Level	t <sub>PLH</sub>		5	60	μs	I <sub>F</sub> = 0.5 mA, V <sub>CC</sub> = 5.0 V, R <sub>L</sub> = 4.7 kΩ I <sub>F</sub> = 5 mA, V <sub>CC</sub> = 5.0 V, R <sub>L</sub> = 680 kΩ	
Propagation Delay Time To Low Output Level	t <sub>PHL</sub>		8	100	μs	I <sub>F</sub> = 0.5 mA, V <sub>CC</sub> = 5.0 V, R <sub>L</sub> = 4.7 kΩ I <sub>F</sub> = 5 mA, V <sub>CC</sub> = 5.0 V, R <sub>L</sub> = 680 kΩ	

**TYPICAL CHARACTERISTICS**T<sub>a</sub> = 25°C, V<sub>CC</sub> = 5V Each Channel

PARAMETER	SYMBOL	MIN	TYP	MAX	UNITS	TEST CONDITIONS	NOTE
Input Capacitance	C <sub>IN</sub>		60		pF	V <sub>F</sub> = 0, f = 1 MHz, t <sub>a</sub> = 25°C	
Capacitance (Input-Output)	C <sub>I-O</sub>		1.5		pF	f = 1 MHz, t <sub>a</sub> = 25°C	2
Input Diode Temperature Coefficient	$\frac{\Delta V_F}{\Delta T_A}$		-1.8		mV/°C	I <sub>F</sub> = 1.6 mA	
Resistance (Input-Output)	R <sub>I-O</sub>		10 <sup>12</sup>		Ω	V <sub>I-O</sub> = 500 V, t <sub>a</sub> = 25°C	2
Common Mode Transient immunity at High Output Level	CM <sub>H</sub>	500	1000		V/μs	V <sub>CM</sub> = 50 V P-P, V <sub>CC</sub> = 5.0 V, R <sub>L</sub> = 1.5 kΩ, I <sub>F</sub> = 0 mA t <sub>a</sub> = 25°C	3, 5
Common Mode Transient Immunity at Low Output Level	CM <sub>L</sub>	500	1000		V/μs	V <sub>CM</sub> = 50 V P-P, V <sub>CC</sub> = 5.0 V, R <sub>L</sub> = 1.5 kΩ, I <sub>F</sub> = 1.6 mA t <sub>a</sub> = 25°C	4, 5

**NOTES:**

- CURRENT TRANSFER RATIO is defined as the ratio of output collector current, I<sub>O</sub>, to the forward LED input current, I<sub>F</sub>, times 100%.
- Device considered a two-terminal device. Pins 1 and 6 are shorted together and pins 3-5 are shorted together.
- CM<sub>H</sub> is the maximum tolerable common mode transient to assure that the output will remain in a high logic state (i.e. V<sub>O</sub> > 2.0V).
- CM<sub>L</sub> is the maximum tolerable common mode transient to assure that the output will remain in a low logic state (i.e. V<sub>O</sub> < 0.8V).
- In applications where dv/dt may exceed 50,000 V/μs (such as static discharge) a series resistor, R<sub>CC</sub>, should be included to protect the detector ICs from destructively high surge currents. The recommended value is R<sub>CC</sub> =  $\frac{1 \text{ V} \cdot \text{k}\Omega}{0.6 \text{ I}_F(\text{mA})}$

**RECOMMENDED OPERATING CONDITIONS:**

PARAMETER	SYMBOL	MIN	MAX	UNITS
Input Current, Low Level	I <sub>FL</sub>	0	2	μA
Input Current, High Level	I <sub>FH</sub>	0.5	5	mA
Supply Voltage	V <sub>CC</sub>	2.0	18	V

**SELECTION GUIDE**

PART NUMBER	PART DESCRIPTION
66252-000	Screened, full mil-temp (-55° to +125°C)
66252-002	Military operating range (-55° to +125°C)
66252-003	Commercial

Micropac Industries cannot assume any responsibility for any circuits shown or represent that they are free from patent infringement. Micropac reserves the right to make changes at any time in order to improve design and to supply the best product possible.