

---

# HD74LV157A

Quad. 2-to-1 line Data Selectors / Multiplexers  
(Noninverted Outputs)

## HITACHI

ADE-205-263 (Z)

1st Edition  
March 1999

---

### Description

The HD74LV157A has four 2-input digital multiplexers with common select and strobe inputs. When the strobe input is low, a 4-bit word is selected from one of two sources and is routed to the four outputs.

The device provides true data.

Low-voltage and high-speed operation is suitable for the battery-powered products (e.g., notebook computers), and the low-power consumption extends the battery life.

### Features

- $V_{CC} = 2.0\text{ V}$  to  $5.5\text{ V}$  operation
- All inputs  $V_{IH}(\text{Max.}) = 5.5\text{ V}$  ( $@V_{CC} = 0\text{ V}$  to  $5.5\text{ V}$ )
- All outputs  $V_O(\text{Max.}) = 5.5\text{ V}$  ( $@V_{CC} = 0\text{ V}$ )
- Typical  $V_{OL}$  ground bounce  $< 0.8\text{ V}$  ( $@V_{CC} = 3.3\text{ V}$ ,  $T_a = 25^\circ\text{C}$ )
- Typical  $V_{OH}$  undershoot  $> 2.3\text{ V}$  ( $@V_{CC} = 3.3\text{ V}$ ,  $T_a = 25^\circ\text{C}$ )
- Output current  $\pm 6\text{ mA}$  ( $@V_{CC} = 3.0\text{ V}$  to  $3.6\text{ V}$ ),  $\pm 12\text{ mA}$  ( $@V_{CC} = 4.5\text{ V}$  to  $5.5\text{ V}$ )

# HD74LV157A

## Function Table

### Inputs

STB	SEL	A	B	Output
H	X	X	X	L
L	L	L	X	L
L	L	H	X	H
L	H	X	L	L
L	H	X	H	H

Note: H: High level  
L: Low level  
X: Immaterial

## Pin Arrangement

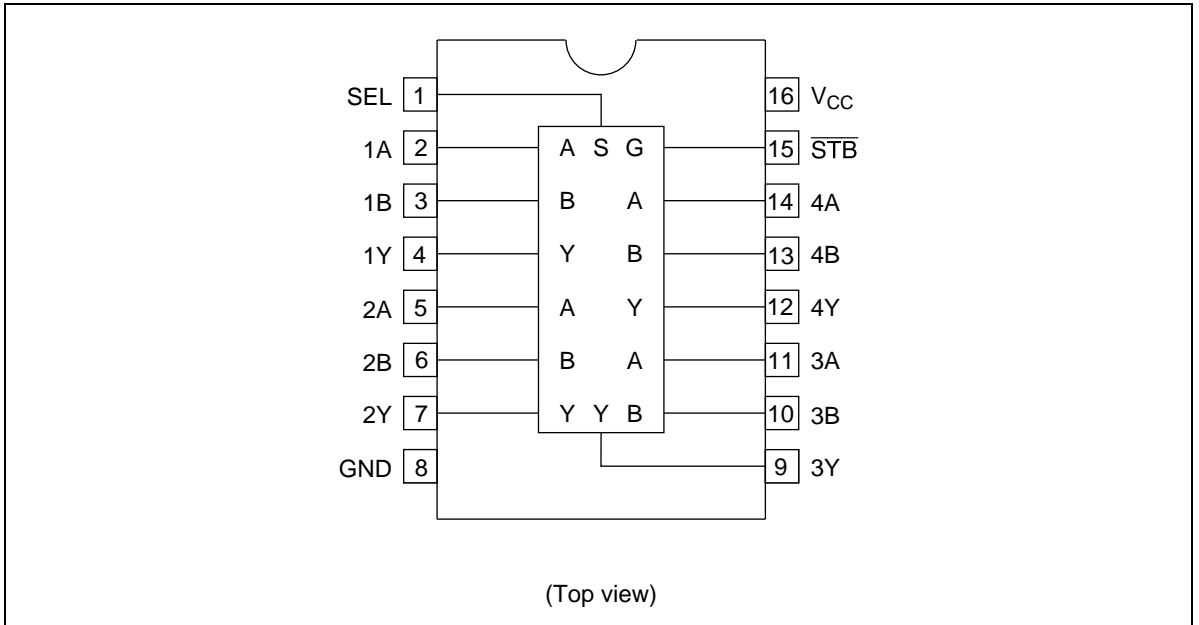

**Absolute Maximum Ratings**

Item	Symbol	Ratings	Unit	Conditions
Supply voltage range	$V_{CC}$	-0.5 to 7.0	V	
Input voltage range* <sup>1</sup>	$V_I$	-0.5 to 7.0	V	
Output voltage range* <sup>1, 2</sup>	$V_O$	-0.5 to $V_{CC} + 0.5$ -0.5 to 7.0	V	Output: H or L $V_{CC}$ : OFF
Input clamp current	$I_{IK}$	-20	mA	$V_I < 0$
Output clamp current	$I_{OK}$	$\pm 50$	mA	$V_O < 0$ or $V_O > V_{CC}$
Continuous output current	$I_O$	$\pm 25$	mA	$V_O = 0$ to $V_{CC}$
Continuous current through $V_{CC}$ or GND	$I_{CC}$ or $I_{GND}$	$\pm 50$	mA	
Maximum power dissipation at $T_a = 25^\circ\text{C}$ (in still air)* <sup>3</sup>	$P_T$	785	mW	SOP
		500		TSSOP
Storage temperature	$T_{stg}$	-65 to 150	$^\circ\text{C}$	

Notes: The absolute maximum ratings are values which must not individually be exceeded, and furthermore, no two of which may be realized at the same time.

1. The input and output voltage ratings may be exceeded if the input and output clamp-current ratings are observed.
2. This value is limited to 5.5 V maximum.
3. The maximum package power dissipation was calculated using a junction temperature of  $150^\circ\text{C}$ .

# HD74LV157A

## Recommended Operating Conditions

Item	Symbol	Min	Max	Unit	Conditions
Supply voltage range	$V_{CC}$	2.0	5.5	V	
Input voltage range	$V_I$	0	5.5	V	
Output voltage range	$V_O$	0	$V_{CC}$	V	H or L
Output current	$I_{OH}$	—	-50	$\mu A$	$V_{CC} = 2.0 V$
		—	-2	mA	$V_{CC} = 2.3 \text{ to } 2.7 V$
		—	-6		$V_{CC} = 3.0 \text{ to } 3.6 V$
		—	-12		$V_{CC} = 4.5 \text{ to } 5.5 V$
	$I_{OL}$	—	50	$\mu A$	$V_{CC} = 2.0 V$
		—	2	mA	$V_{CC} = 2.3 \text{ to } 2.7 V$
		—	6		$V_{CC} = 3.0 \text{ to } 3.6 V$
		—	12		$V_{CC} = 4.5 \text{ to } 5.5 V$
Input transition rise or fall rate	$\Delta t/\Delta v$	0	200	ns/V	$V_{CC} = 2.3 \text{ to } 2.7 V$
		0	100		$V_{CC} = 3.0 \text{ to } 3.6 V$
		0	20		$V_{CC} = 4.5 \text{ to } 5.5 V$
Operating free-air temperature	$T_a$	-40	85	$^{\circ}C$	

Note: Unused or floating inputs must be held high or low.

Logic Diagram

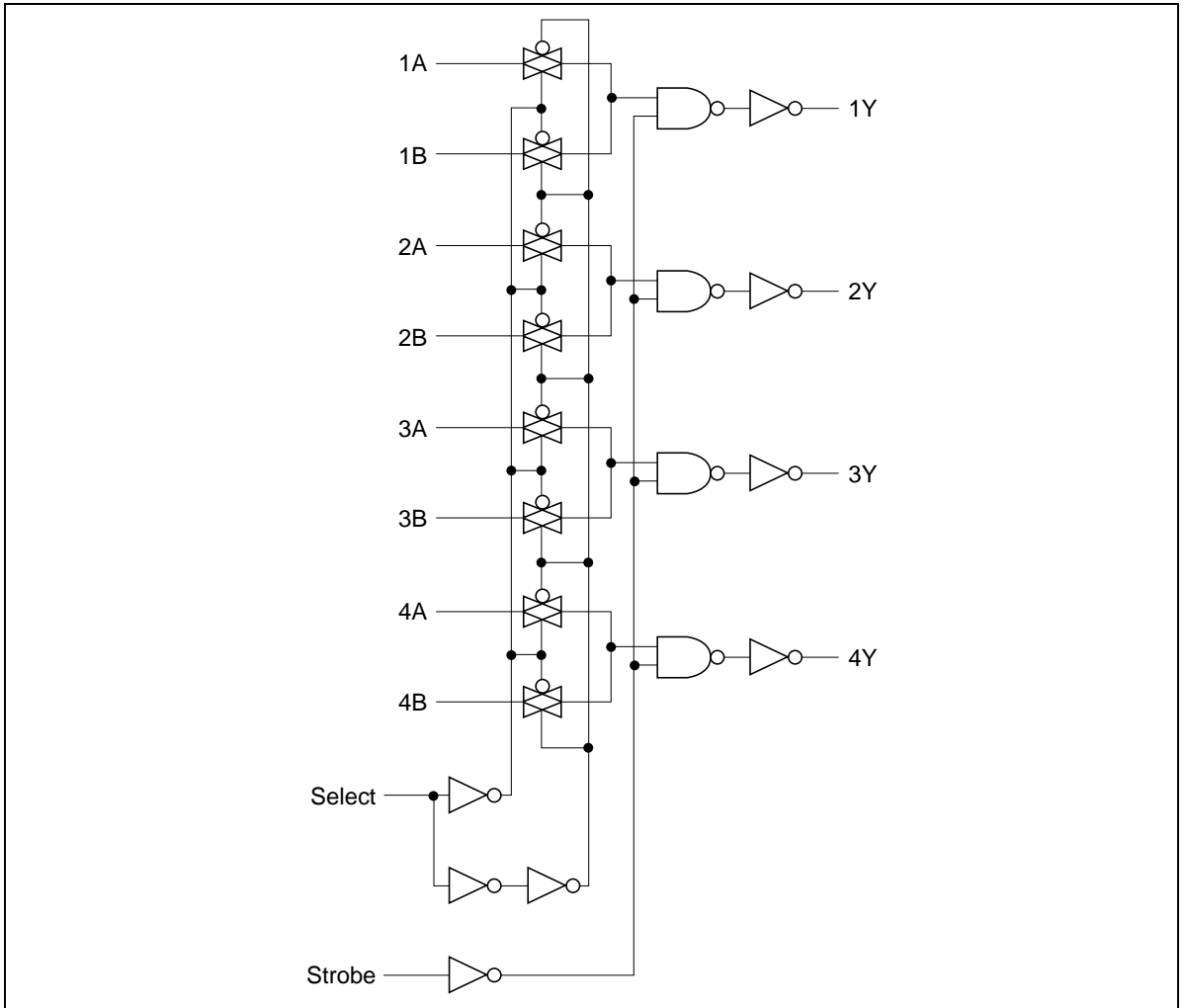

# HD74LV157A

## DC Electrical Characteristics

Ta = -40 to 85°C

Item	Symbol	V <sub>CC</sub> (V)*	Min	Typ	Max	Unit	Test Conditions
Input voltage	V <sub>IH</sub>	2.0	1.5	—	—	V	
		2.3 to 2.7	V <sub>CC</sub> × 0.7	—	—		
		3.0 to 3.6	V <sub>CC</sub> × 0.7	—	—		
		4.5 to 5.5	V <sub>CC</sub> × 0.7	—	—		
	V <sub>IL</sub>	2.0	—	—	0.5		
		2.3 to 2.7	—	—	V <sub>CC</sub> × 0.3		
		3.0 to 3.6	—	—	V <sub>CC</sub> × 0.3		
		4.5 to 5.5	—	—	V <sub>CC</sub> × 0.3		
Output voltage	V <sub>OH</sub>	Min to Max	V <sub>CC</sub> - 0.1	—	—	V	I <sub>OH</sub> = -50 μA
		2.3	2.0	—	—		I <sub>OH</sub> = -2 mA
		3.0	2.48	—	—		I <sub>OH</sub> = -6 mA
		4.5	3.8	—	—		I <sub>OH</sub> = -12 mA
	V <sub>OL</sub>	Min to Max	—	—	0.1		I <sub>OL</sub> = 50 μA
		2.3	—	—	0.4		I <sub>OL</sub> = 2 mA
		3.0	—	—	0.44		I <sub>OL</sub> = 6 mA
		4.5	—	—	0.55		I <sub>OL</sub> = 12 mA
Input current	I <sub>IN</sub>	0 to 5.5	—	—	±1	μA	V <sub>I</sub> = 5.5 V or GND
Quiescent supply current	I <sub>CC</sub>	5.5	—	—	20	μA	V <sub>I</sub> = V <sub>CC</sub> or GND, I <sub>O</sub> = 0
Output leakage current	I <sub>OFF</sub>	0	—	—	5	μA	V <sub>I</sub> or V <sub>O</sub> = 0 V to 5.5 V
Input capacitance	C <sub>IN</sub>	3.3	—	1.9	—	pF	V <sub>I</sub> = V <sub>CC</sub> or GND

Note: For conditions shown as Min or Max, use the appropriate values under recommended operating conditions.

Switching Characteristics

$V_{CC} = 2.5 \pm 0.2 \text{ V}$

Item	Symbol	Ta = 25°C			Ta = -40 to 85°C		Unit	Test Conditions	FROM (Input)	TO (Output)
		Min	Typ	Max	Min	Max				
Propagation delay time	$t_{PLH}/t_{PHL}$	—	9.8	15.9	1.0	19.5	ns	$C_L = 15 \text{ pF}$	A or B	Y
		—	13.3	18.8	1.0	22.0		$C_L = 50 \text{ pF}$		
		—	15.5	19.4	1.0	23.5		$C_L = 15 \text{ pF}$	SEL	
		—	15.7	22.3	1.0	26.0		$C_L = 50 \text{ pF}$		
		—	15.8	19.8	1.0	24.0		$C_L = 15 \text{ pF}$	STB	
		—	14.8	22.7	1.0	26.5		$C_L = 50 \text{ pF}$		

$V_{CC} = 3.3 \pm 0.3 \text{ V}$

Item	Symbol	Ta = 25°C			Ta = -40 to 85°C		Unit	Test Conditions	FROM (Input)	TO (Output)
		Min	Typ	Max	Min	Max				
Propagation delay time	$t_{PLH}/t_{PHL}$	—	6.2	9.7	1.0	11.5	ns	$C_L = 15 \text{ pF}$	A or B	Y
		—	8.7	13.2	1.0	15.0		$C_L = 50 \text{ pF}$		
		—	8.4	13.2	1.0	15.5		$C_L = 15 \text{ pF}$	SEL	
		—	10.9	16.7	1.0	19.0		$C_L = 50 \text{ pF}$		
		—	8.7	13.6	1.0	16.0		$C_L = 15 \text{ pF}$	STB	
		—	11.2	17.1	1.0	19.5		$C_L = 50 \text{ pF}$		

# HD74LV157A

## Switching Characteristics (cont)

$$V_{CC} = 5.0 \pm 0.5 \text{ V}$$

Item	Symbol	Ta = 25°C			Ta = -40 to 85°C		Unit	Test Conditions	FROM (Input)	TO (Output)
		Min	Typ	Max	Min	Max				
Propagation delay time	t <sub>PLH</sub> /t <sub>PHL</sub>	—	4.1	6.4	1.0	7.5	ns	C <sub>L</sub> = 15 pF	A or B	Y
		—	5.6	8.4	1.0	9.5		C <sub>L</sub> = 50 pF		
		—	5.3	8.1	1.0	9.5		C <sub>L</sub> = 15 pF	SEL	
		—	6.8	10.1	1.0	11.5		C <sub>L</sub> = 50 pF		
		—	5.6	8.6	1.0	10.0		C <sub>L</sub> = 15 pF	STB	
		—	7.1	10.6	1.0	12.0		C <sub>L</sub> = 50 pF		

## Operating Characteristics

$$C_L = 50 \text{ pF}$$

Item	Symbol	V <sub>CC</sub> (V)	Ta = 25°C			Unit	Test Conditions
			Min	Typ	Max		
Power dissipation capacitance	C <sub>PD</sub>	3.3	—	10.0	—	pF	f = 10 MHz
		5.0	—	12.0	—		

**Noise Characteristics**

$C_L = 50 \text{ pF}$

Item	Symbol	$V_{CC}$ (V)	$T_a = 25^\circ\text{C}$			Unit	Test Conditions
			Min	Typ	Max		
Quiet output, maximum dynamic $V_{OL}$	$V_{OL(P)}$	3.3	—	0.3	0.8	V	
Quiet output, minimum dynamic $V_{OL}$	$V_{OL(V)}$	3.3	—	-0.2	-0.8		
Quiet output, minimum dynamic $V_{OH}$	$V_{OH(V)}$	3.3	—	3.0	—		
High-level dynamic input voltage	$V_{IH(D)}$	3.3	2.31	—	—	V	
Low-level dynamic input voltage	$V_{IL(D)}$	3.3	—	—	0.99		

**Test Circuit**

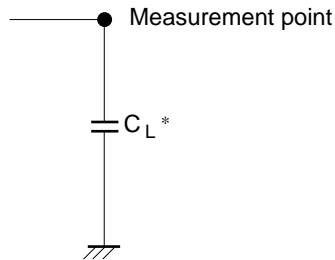

Note:  $C_L$  includes the probe and jig capacitance.

# HD74LV157A

## • Waveform

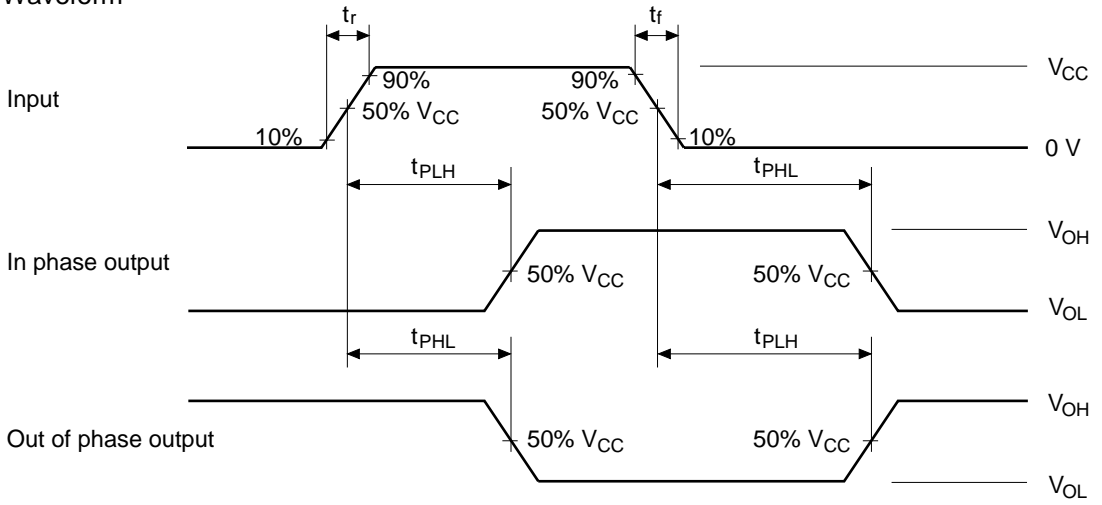

- Notes: 1. Input waveform:  $PRR \leq 1 \text{ MHz}$ ,  $Z_o = 50 \Omega$ ,  $t_r \leq 3 \text{ ns}$ ,  $t_f \leq 3 \text{ ns}$   
2. The output is measured one at a time with one transition per measurement.

Package Dimensions

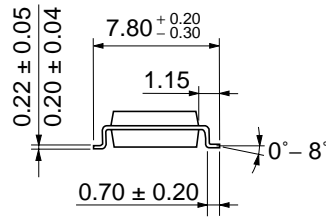
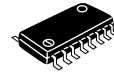
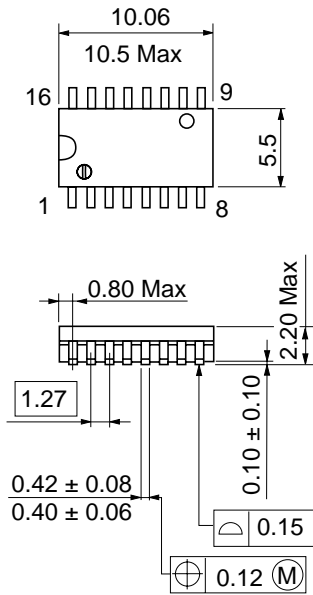

Dimension including the plating thickness  
Base material dimension

Hitachi Code	FP-16DA
JEDEC	-
EIAJ	Conforms
Weight (reference value)	0.24 g

# HD74LV157A

Unit: mm

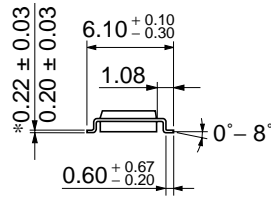
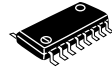
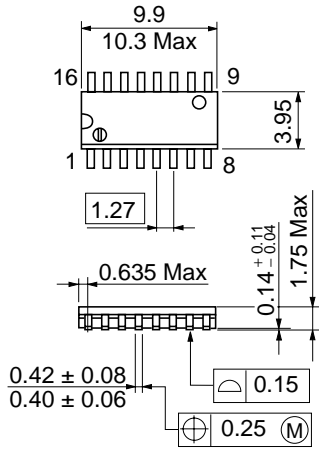

Dimension including the plating thickness  
Base material dimension

Hitachi Code	FP-16DN
JEDEC	Conforms
EIAJ	Conforms
Weight (reference value)	0.15 g

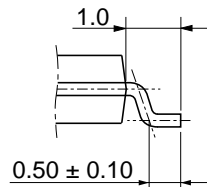
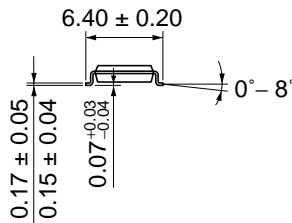
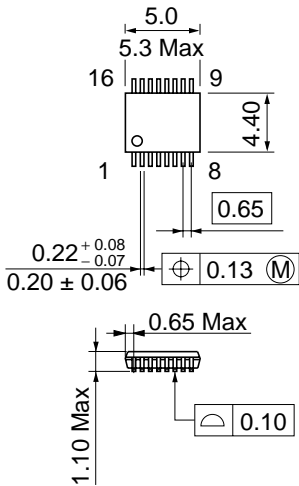

Dimension including the plating thickness  
Base material dimension

Hitachi Code	TTP-16DA
JEDEC	-
EIAJ	-
Weight (reference value)	0.05 g

**Disclaimer**

1. Hitachi neither warrants nor grants licenses of any rights of Hitachi's or any third party's patent, copyright, trademark, or other intellectual property rights for information contained in this document. Hitachi bears no responsibility for problems that may arise with third party's rights, including intellectual property rights, in connection with use of the information contained in this document.
2. Products and product specifications may be subject to change without notice. Confirm that you have received the latest product standards or specifications before final design, purchase or use.
3. Hitachi makes every attempt to ensure that its products are of high quality and reliability. However, contact Hitachi's sales office before using the product in an application that demands especially high quality and reliability or where its failure or malfunction may directly threaten human life or cause risk of bodily injury, such as in aerospace, aeronautics, nuclear power, combustion control, transportation, traffic, safety equipment or medical equipment for life support.
4. Design your application so that the product is used within the ranges guaranteed by Hitachi particularly for maximum rating, operating supply voltage range, heat radiation characteristics, installation conditions and other characteristics. Hitachi bears no responsibility for failure or damage when used beyond the guaranteed ranges. Even within the guaranteed ranges, consider normally foreseeable failure rates or failure modes in semiconductor devices and employ systemic measures such as fail-safe devices, so that the equipment incorporating the Hitachi product does not cause bodily injury, fire or other consequential damage due to operation of the Hitachi product.
5. This product is not designed to be radiation resistant.
6. No one is permitted to reproduce or duplicate, in any form, the whole or part of this document without written approval from Hitachi.
7. Contact Hitachi's sales office for any questions regarding this document or Hitachi semiconductor products.

**Sales Offices**

---



---

# HITACHI

**Hitachi, Ltd.**

Semiconductor & Integrated Circuits.  
 Nippon Bldg., 2-6-2, Ohte-machi, Chiyoda-ku, Tokyo 100-0004, Japan  
 Tel: Tokyo (03) 3270-2111 Fax: (03) 3270-5109

URL      NorthAmerica      : <http://semiconductor.hitachi.com/>  
           Europe                : <http://www.hitachi-eu.com/hel/ecg>  
           Asia                     : <http://sicapac.hitachi-asia.com>  
           Japan                    : <http://www.hitachi.co.jp/Sicd/indx.htm>

**For further information write to:**

Hitachi Semiconductor  
 (America) Inc.  
 179 East Tasman Drive,  
 San Jose, CA 95134  
 Tel: <1> (408) 433-1990  
 Fax: <1> (408) 433-0223

Hitachi Europe GmbH  
 Electronic Components Group  
 Domacher Straße 3  
 D-85622 Feldkirchen, Munich  
 Germany  
 Tel: <49> (89) 9 9180-0  
 Fax: <49> (89) 9 29 30 00

Hitachi Europe Ltd.  
 Electronic Components Group.  
 Whitebrook Park  
 Lower Cookham Road  
 Maidenhead  
 Berkshire SL6 8YA, United Kingdom  
 Tel: <44> (1628) 585000  
 Fax: <44> (1628) 585160

Hitachi Asia Ltd.  
 Hitachi Tower  
 16 Collyer Quay #20-00,  
 Singapore 049318  
 Tel: <65>-538-6533/538-8577  
 Fax: <65>-538-6933/538-3877  
 URL : <http://www.hitachi.com.sg>

Hitachi Asia Ltd.  
 (Taipei Branch Office)  
 4/F, No. 167, Tun Hwa North Road,  
 Hung-Kuo Building,  
 Taipei (105), Taiwan  
 Tel: <886>-(2)-2718-3666  
 Fax: <886>-(2)-2718-8180  
 Telex : 23222 HAS-TP  
 URL : <http://www.hitachi.com.tw>

Hitachi Asia (Hong Kong) Ltd.  
 Group III (Electronic Components)  
 7/F., North Tower,  
 World Finance Centre,  
 Harbour City, Canton Road  
 Tsim Sha Tsui, Kowloon,  
 Hong Kong  
 Tel : <852>-(2)-735-9218  
 Fax : <852>-(2)-730-0281  
 URL : <http://www.hitachi.com.hk>

Copyright © Hitachi, Ltd., 2001. All rights reserved. Printed in Japan.  
 Colophon 2.0