

Temperature profile of reflow soldering

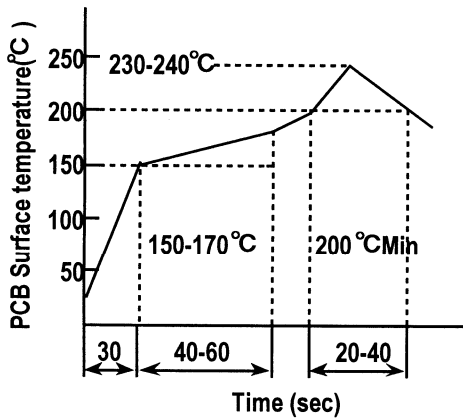

Foot Pattern

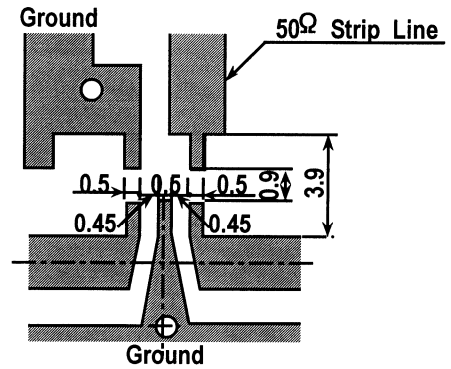

Embossed Carrier Tape Dimensions

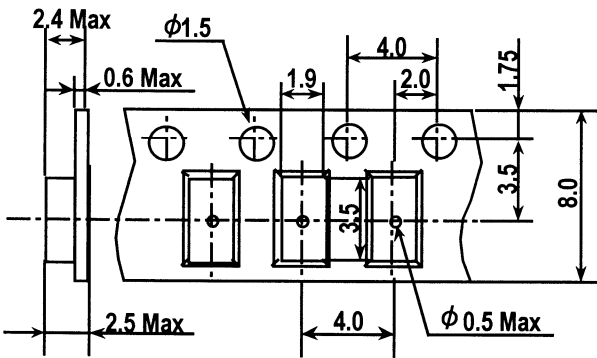

Package

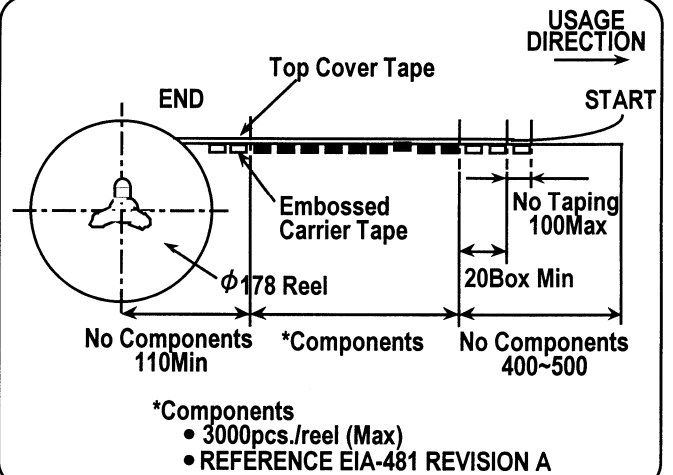

Setting Direction

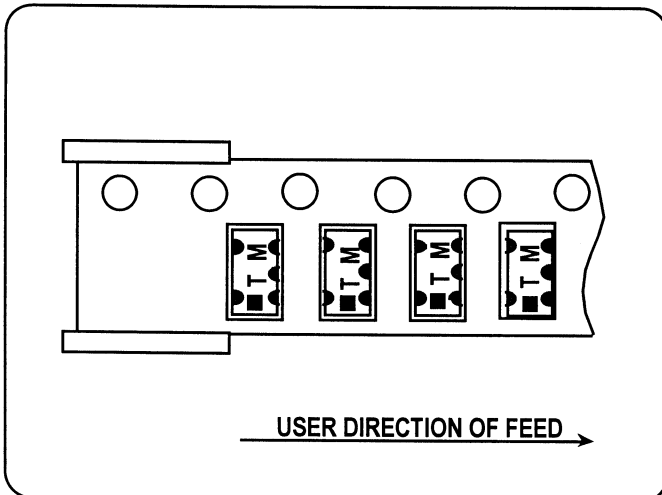

Applicable Model. No.

- *SLT-180T-1
- *SLT-180T-2
- *SLT-180T-3