

NOTES:

1. MATERIALS AND FINISHES (IN MICRO-INCHES):

- BODY = ZINC DIECAST, MATTE TIN PL. 100 MIN. THICK OVER NICKEL PL. 100 MIN. THICK OVER COPPER PL. (250 MIN./300 MAX.) THICK
- CONTACT = BRASS, GOLD PL. 5 MIN. THICK OVER PHOSPHORUS CONTENT 9%-13% ELECTROLESS NICKEL PL. 100 MIN. THICK
- INSULATOR = PTFE, COLOR: NATURAL.
- COVER = BRASS, MATTE TIN PL. 100 MIN. THICK OVER NICKEL PL. 100 MIN. THICK OVER COPPER STRIKE
- HOUSING = NYLON 46, COLOR & KEYING PER FAKRA-KEY-PLUG (REFER TO TABLE BELOW FOR KEY CODE)

2. ELECTRICAL:

- A. FREQUENCY RANGE: DC- 3 GHz
- B. VSWR: 1.200 (DC-3.0 GHz)

3. MECHANICAL:

- A. DURABILITY: 100 CYCLES MIN.
- B. TEMPERATURE RANGE: -40° C TO +85° C
- C. HOUSING RETENTION: 110N MIN. (AXIAL)

4. PACKAGING:

- A. QUANTITY: TRAY PACK
- B. MARKING: TRAY TO BE MARKED "AMPHENOL, 2FAI-SXRP-PCBB2, AND DATE CODE"

THIRD ANGLE PROJ.

REVISIONS

REV	DESCRIPTION	DATE	ECO	APPR
A	RELEASE TO MFG.	05-Aug-10	48135	JY
B	MODIFIED BODY \RD-DMI2022901K\	07-Mar-12	48978	JY

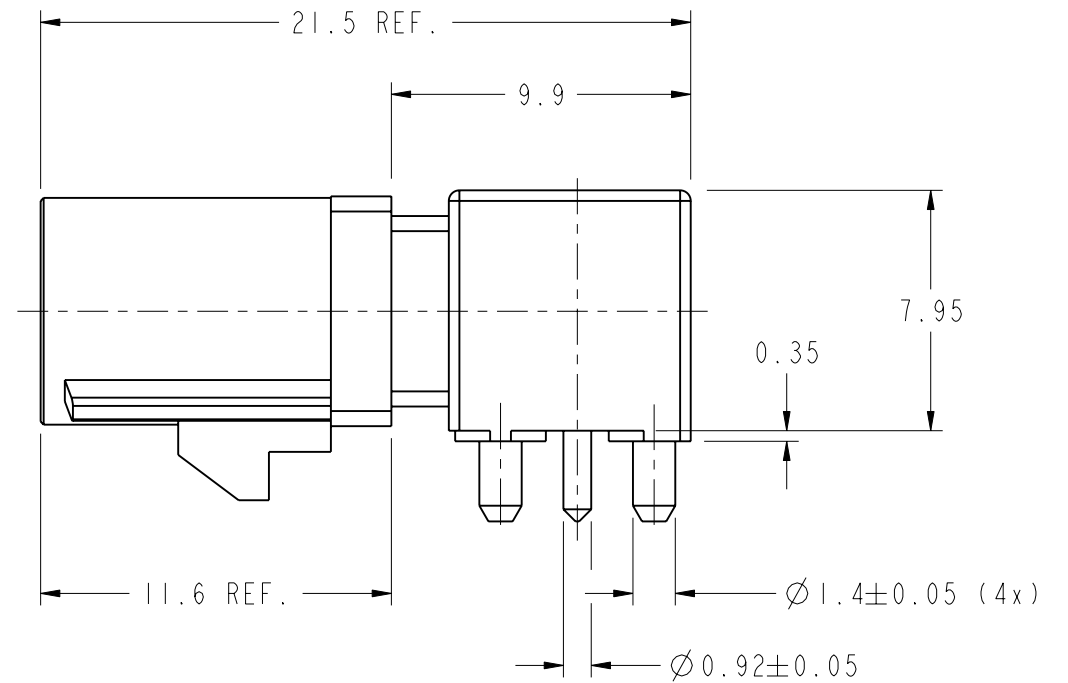
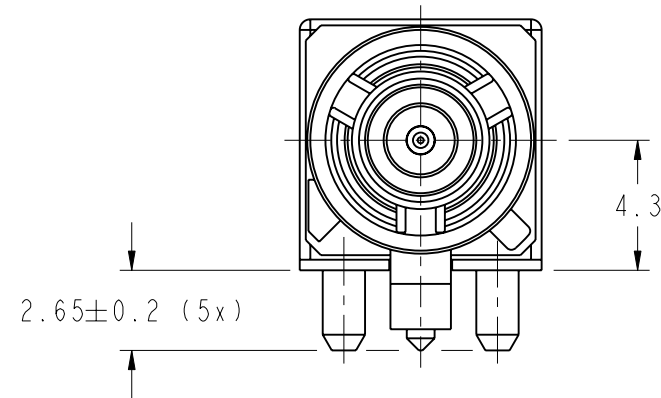

CONFIGURATION CONTROL:
NO CHANGES PERMITTED TO DRAWING WITHOUT PPAP QUALIFIED CUSTOMER APPROVAL

CODING	DRAWING NO.	COLOR	RAL NO.
A	2FAI-SARP-PCBB2	JET BLACK	9005
B	2FAI-SBRP-PCBB2	CREAM	9001
C	2FAI-SCRP-PCBB2	SIGNAL BLUE	5005
D	2FAI-SDRP-PCBB2	CLARET VIOLET	4004
E	2FAI-SERP-PCBB2	LEAF GREEN	6002
F	2FAI-SFRP-PCBB2	NUT BROWN	8011
G	2FAI-SGRP-PCBB2	BLUE GREY	7031
H	2FAI-SHRP-PCBB2	HEATHER VIOLET	4003
I	2FAI-SIRP-PCBB2	BEIGE	1001
K	2FAI-SKRP-PCBB2	CURRY	1027
L	2FAI-SLRP-PCBB2	CARMINE RED	3002
M	2FAI-SMRP-PCBB2	PASTEL ORANGE	2003
N	2FAI-SNRP-PCBB2	PASTEL GREEN	6019
Z	2FAI-SZRP-PCBB2	WATER BLUE	5021

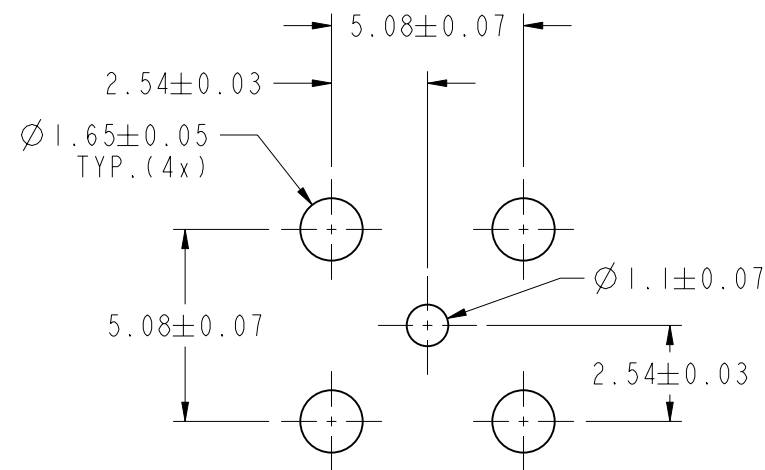

RECOMMENDED PCB LAYOUT

SCALE 5.000

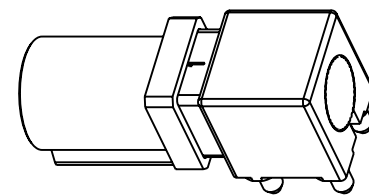

SCALE 2.000

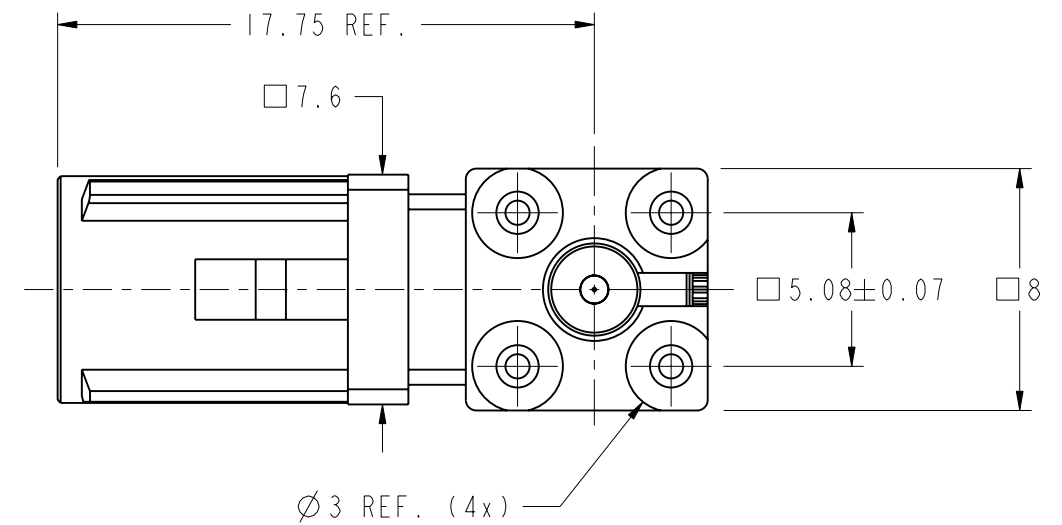
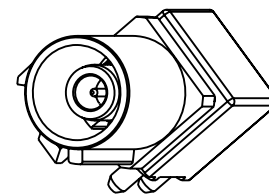

CUSTOMER OUTLINE DRAWING

ALL OTHER SHEETS ARE FOR INTERNAL USE ONLY

UNLESS OTHERWISE SPECIFIED, DIMENSIONS ARE IN METRIC AND TOLERANCES ARE:
 <0.5mm ±0.05mm 0.5 - 6mm ±0.1mm 6 - 30mm ±0.2mm 30 - 120mm ±0.3mm ANGLES ±1°

NOTICE - These drawings, specifications, or other data (1) are, and remain the property of Amphenol corp. (2) must be returned upon request; and (3) are confidential and not to be disclosed to any person other than those to whom they are given by Amphenol Corp. the finishing of these drawings, specifications, or other data by Amphenol Corp., or to any other person to anyone for any purpose is not to be regarded by implication or otherwise in any manner licensing, granting rights to permitting such holder or any other person to manufacture, use or sell any product, process or design, patented or otherwise, that may in any way be related to or disclosed by said drawings, specifications, or other data.

MATERIAL	DRAWN K.LIAO	DATE 07-Mar-12	TITLE FAKRA PLUG, R/A, PCB, SOUTH		Amphenol RF Danbury CT USA, Tainan, Taiwan, Shenzhen, China www.amphenolrf.com	
REFERENCE EAR #3958 AND	ENGINEER B.C. GLEISSNER	DATE 04-Mar-10				
CONFIGURATION LEVEL:	APPROVED S.HSIEH	DATE 08-Mar-12	SCALE: 5.0:1.0	SHEET 2 OF 2	DRAWING NO. 2FAI-SXRP-PCBB2	ITEM NO. 2FAI-SXRP-PCBB2
FINISH	CAD FILE I:\FAKRA\2FAI-SXRP-PCBB2		DWG SIZE B	REV B	PART NO. 2FAI-SXRP-PCBB2	