

ADSP-1081A

FEATURES

- 8 × 8-Bit Parallel Multiplication**
- 30MHz Multiplication Rate**
- 275mW Power Dissipation with TTL-Compatible CMOS Technology**
- Unsigned-Magnitude Data Format**
- Available in Hermetically-Sealed 40-Pin DIP or Plastic 40-Pin DIP**
- Available Specified from -55°C to +125°C Ambient**
- Pin-Compatible with ADSP-1081 and MPY08HUJ5**

APPLICATIONS

- Digital Signal Processing**
- Digital Filtering**
- Fourier Transformations**
- Correlations**
- Image Processing**

GENERAL DESCRIPTION

The ADSP-1081A is a high-speed, low-power 8 × 8-bit parallel multiplier fabricated in 1.5 micron CMOS.

The ADSP-1081A has two 8-bit input ports, an 8-bit Most Significant Product (MSP) port, and an 8-bit Least Significant Product (LSP) port. Input data is interpreted in unsigned-magnitude format. The ADSP-1081A produces a 16-bit result whose unsigned-magnitude MSP can be rounded with a control which causes a 1 to be added to the Most Significant Bit (MSB) of the LSP.

All input pins are diode-protected. The input and output registers are all D-type positive-edge-triggered flip-flops. The input registers are controlled by independent clock lines. A third clock line controls the product registers. Both of the product registers have their own three-state output controls. Three-state outputs and independently-clocked inputs allow the ADSP-1081A to be connected directly to a single 8-bit bus.

The ADSP-1081A is a pin-for-pin replacement for Analog Devices' ADSP-1081 and is also pin-for-pin compatible in a DIP package with TRW's MPY08HUJ5 and MPY08HUJ5-1. The ADSP-1081A's multiply time is less than either TRW device.

ADSP-1081A FUNCTIONAL BLOCK DIAGRAM

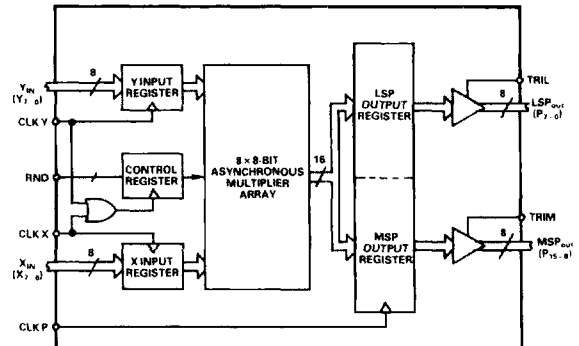

The power consumption of the ADSP-1081A is 275mW maximum, less than 15% of the power required by equivalent bipolar devices. The differential between the ADSP-1081A's junction temperature and the ambient temperature stays small because of this low power dissipation. Thus, the ADSP-1081A can be safely specified for operation at environmental temperatures over its extended temperature range (-55°C to +125°C ambient).

The ADSP-1081A is available for both commercial and military temperature ranges. Extended temperature range parts are available with high-reliability processing ("PLUS" parts). MIL-grade parts are available processed fully to MIL-STD-883, Class B. Additionally, the ADSP-1081A is available in either a 40-pin hermetically-sealed ceramic DIP or a plastic 40-pin DIP.