

TYPES SN5482, SN7482 2-BIT BINARY FULL ADDERS

DECEMBER 1972—REVISED DECEMBER 1983

For applications in:

- Digital Computer Systems
- Data-Handling Systems
- Control Systems

logic

SN5482 ... J OR W PACKAGE
SN7482 ... J OR N PACKAGE
(TOP VIEW)

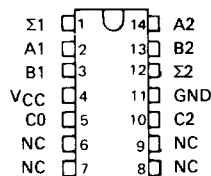

NC - No internal connection

FUNCTION TABLE

INPUTS				OUTPUTS					
				WHEN C0 = L			WHEN C0 = H		
A1	B1	A2	B2	Σ1	Σ2	C2	Σ1	Σ2	C2
L	L	L	L	L	L	L	H	L	L
H	L	L	L	H	L	L	L	H	L
L	H	L	L	H	L	L	L	H	L
H	H	L	L	L	H	L	H	H	L
L	L	H	L	L	H	L	H	H	L
H	L	H	L	H	H	L	L	L	H
L	H	H	L	H	H	L	L	L	H
H	H	H	L	L	L	H	H	L	H
L	L	L	H	L	H	L	H	H	L
H	L	L	H	H	H	L	L	L	H
L	H	L	H	H	H	L	L	L	H
H	H	L	H	L	L	H	H	L	H
L	L	H	H	L	L	H	H	L	H
H	L	H	H	H	L	H	L	H	H
L	H	H	H	H	L	H	L	H	H
H	H	H	H	L	H	H	H	H	H

H = high level, L = low level

description

These full adders perform the addition of two 2-bit binary numbers. The sum (Σ) outputs are provided for each bit and the resultant carry (C2) is obtained from the second bit. Designed for medium-to-high-speed, multiple-bit, parallel-add/serial-carry applications, these circuits utilize high-speed, high-fan-out transistor-transistor logic (TTL) and are compatible with both DTL and TTL logic families. The implementation of a single-inversion, high-speed, Darlington-connected serial-carry circuit within each bit minimizes the necessity for extensive "look-ahead" and carry-cascading circuits.

logic diagram

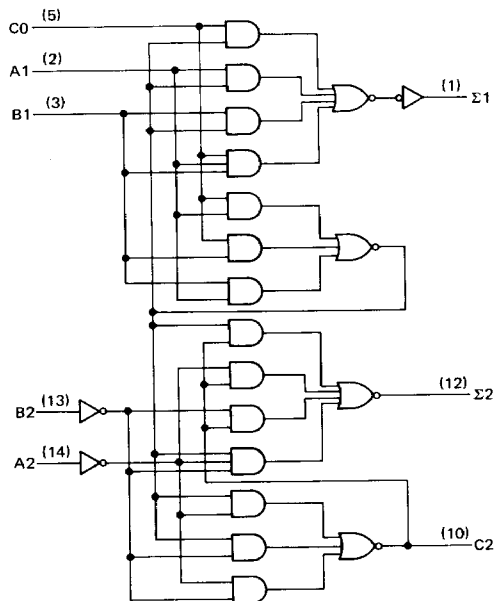

Pin numbers shown on logic notation are for J or N packages.

3
TTL DEVICES

PRODUCTION DATA

This document contains information current as of publication date. Products conform to specifications per the terms of Texas Instruments standard warranty. Production processing does not necessarily include testing of all parameters.

3-330

TEXAS
INSTRUMENTS

POST OFFICE BOX 225012 • DALLAS, TEXAS 75265

absolute maximum ratings over operating free-air temperature range (unless otherwise noted)

Supply voltage, V_{CC} (see Note 1)	7 V
Input voltage (see Note 2)	5.5 V
Operating free-air temperature range: SN5482 Circuits	-55°C to 125°C
SN7482 Circuits	0°C to 70°C
Storage temperature range	-65°C to 150°C

- NOTES: 1. Voltage values are with respect to network ground terminal.
2. Input signals must be zero or positive with respect to network ground terminal.

recommended operating conditions

	SN5482			SN7482			UNIT
	MIN	NOM	MAX	MIN	NOM	MAX	
Supply voltage, V_{CC}	4.5	5	5.5	4.75	5	5.25	V
High-level output current, I_{OH}	$\Sigma 1$ or $\Sigma 2$		-400			-400	μA
	C2		-200			-200	
Low-level output current, I_{OL}	$\Sigma 1$ or $\Sigma 2$		16			16	mA
	C2		8			8	
Operating free-air temperature, T_A	-55		125	0		70	°C

electrical characteristics over recommended operating free-air temperature range (unless otherwise noted)

PARAMETER		TEST CONDITIONS [†]		SN5482			SN7482			UNIT
				MIN	TYP [‡]	MAX	MIN	TYP [‡]	MAX	
V_{IH}	High-level input voltage			2			2			V
V_{IL}	Low-level input voltage			0.8			0.8			V
V_{OH}	High-level output voltage	$\Sigma 1$ or $\Sigma 2$	$V_{CC} = \text{MIN}, V_{IH} = 2 \text{ V}, V_{IL} = 0.4 \text{ V}$	$I_{OH} = -400 \mu A$		2.4	3.4	$I_{OH} = -200 \mu A$		V
		C2		$I_{OH} = -200 \mu A$						
V_{OL}	Low-level output voltage	$\Sigma 1$ or $\Sigma 2$	$V_{CC} = \text{MIN}, V_{IH} = 2 \text{ V}, V_{IL} = 0.4 \text{ V}$	$I_{OL} = 16 \text{ mA}$		0.2	0.4	$I_{OL} = 8 \text{ mA}$		V
		C2		$I_{OL} = 8 \text{ mA}$						
I_I	Input current at maximum input voltage	$V_{CC} = \text{MAX}, V_I = 5.5 \text{ V}$		1			1			mA
I_{IH}	High-level input current	A1, B1, or C0	$V_{CC} = \text{MAX}, V_I = 2.4 \text{ V}$	160			160			μA
		A2 or B2		40			40			
I_{IL}	Low-level input current	A1, B1, or C0	$V_{CC} = \text{MAX}, V_I = 0.4 \text{ V}$	-6.4			-6.4			mA
		A2 or B2		-1.6			-1.6			
I_{OS}	Short-circuit output current [§]	$\Sigma 1$ or $\Sigma 2$	$V_{CC} = \text{MAX}$	-20	-55	-18	-55	-55	mA	
		C2		-20	-70	-18	-70			
I_{CC}	Supply current	$V_{CC} = \text{MAX}, \text{ See Note 3}$		35	50		35	58	mA	

[†]For conditions shown as MIN or MAX, use the appropriate value specified under recommended operating conditions for the applicable type.
[‡]All typical values are at $V_{CC} = 5 \text{ V}, T_A = 25^\circ \text{C}$.
[§]Not more than one output should be shorted at a time.
 NOTE 3: I_{CC} is measured with outputs open, B1 and B2 grounded, and 4.5 V applied to A1, A2, and C0.

3
TTL DEVICES

TYPES SN5482, SN7482 2-BIT BINARY FULL ADDERS

switching characteristics, $V_{CC} = 5\text{ V}$, $T_A = 25^\circ\text{C}$ (see note 4)

PARAMETER [†]	FROM (INPUT)	TO (OUTPUT)	TEST CONDITIONS	MIN	TYP	MAX	UNIT
t_{PLH}	C0	$\Sigma 1$	$C_L = 15\text{ pF}$, $R_L = 400\ \Omega$			34	ns
t_{PHL}						40	
t_{PLH}	B2	$\Sigma 2$				40	ns
t_{PHL}						35	
t_{PLH}	C0	$\Sigma 2$				38	ns
t_{PHL}						42	
t_{PLH}	C0	C2	$C_L = 15\text{ pF}$, $R_L = 780\ \Omega$		12	19	ns
t_{PHL}					17	27	

[†] t_{PLH} = propagation delay time, low-to-high-level output

t_{PHL} = propagation delay time, high-to-low-level output

NOTE 4: See General Information Section for load circuits and voltage waveforms.

schematics of inputs and outputs

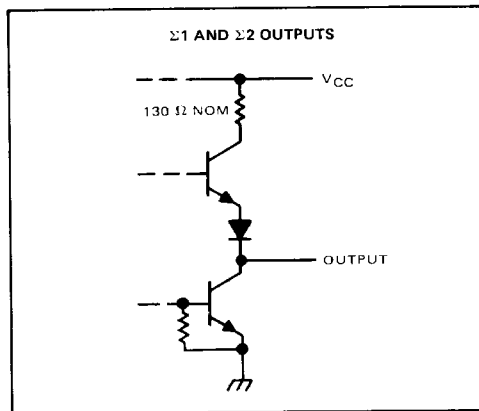
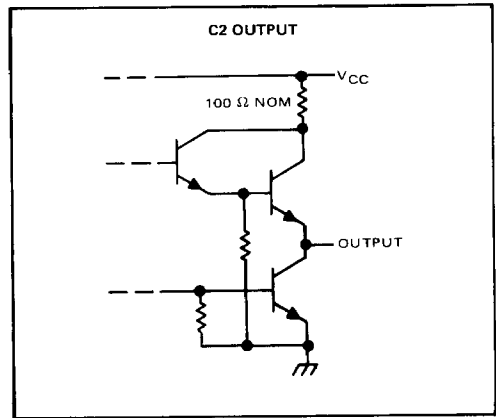
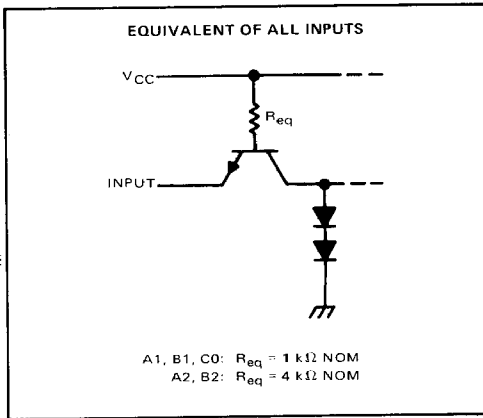

3

TTL DEVICES