

# 10bit 10-channel D/A converter

## BU2505FV

BU2505FV is a high-performance 10bit D/A converter IC that incorporates 10-channel of a R-2R system. Each channel output incorporates a Rail-to Rail output type output with buffer amplifier. This IC utilizes the TTL level input method. RESET pin can keep the output voltage in the lower reference voltage range. REVERSE pin can change the LSB/MSB of 10bit data. Small package (0.65mm pitch and 20pin) is adopted.

### ●Applications

DVD, CD-R, CD-RW, DVC, Digital camera, and other industrial equipments

### ●Features

- 1) High-performance 10bit D/A converter that incorporates 10-channel of a R-2R system.
- 2) RESET pin can keep output voltage of all channels within the lower reference voltage range.
- 3) Digital input compatible with TTL levels.
- 4) 14bit 3wire serial data + RESET signal input, and cascade connection is possible. LSB first / MSB first of 10bit data can be changed by REVERSE pin.

### ●Absolute maximum ratings (Ta=25°C)

Parameter	Symbol	Limits	Unit
Supply voltage	V <sub>CC</sub>	-0.3~+6.0	V
Upper reference voltage of D/A converter	V <sub>DD</sub>	-0.3~+6.0	V
Input voltage	V <sub>IN</sub>	-0.3~+6.0	V
Output voltage	V <sub>OUT</sub>	-0.3~+6.0	V
Power dissipation	P <sub>d</sub>	400*	mW
Operating temperature	T <sub>opr</sub>	-25~+85	°C
Storage temperature	T <sub>stg</sub>	-55~+125	°C

\* Reduced by 4mW for each increase in Ta of 1°C over 25°C.

### ●Recommended operating conditions (Ta=25°C)

Parameter	Symbol	Min.	Typ.	Max.	Unit
Supply voltage	V <sub>CC</sub>	4.5	-	5.5	V

Optical disc ICs

●Block diagram

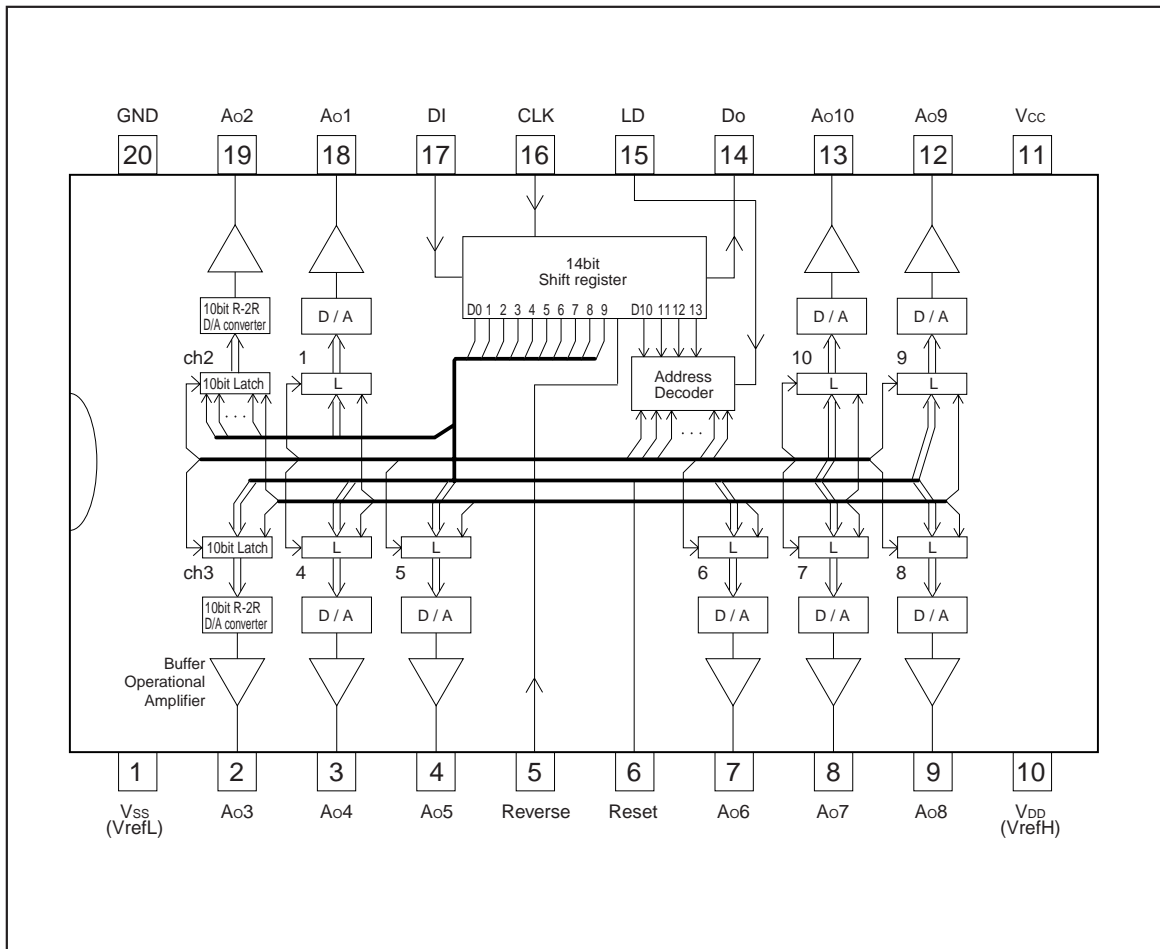

## Optical disc ICs

## ●Pin descriptions

Pin No.	Pin name	Analog / Digital	I / O	Function	Equivalent Circuit
1	V <sub>SS</sub>	Analog	–	D/A converter lower reference voltage input terminal	6
2	Ao3	Analog	O	10bit D/A converter output terminal (CH3)	4
3	Ao4	Analog	O	10bit D/A converter output terminal (CH4)	4
4	Ao5	Analog	O	10bit D/A converter output terminal (CH5)	4
5	Reverse	Digital	I	It is inverted about the data designation 10bit LSB and MSB.	2
6	Reset	Digital	I	The analog output of all channels is fixed for "L".	2
7	Ao6	Analog	O	10bit D/A converter output terminal (CH6)	4
8	Ao7	Analog	O	10bit D/A converter output terminal (CH7)	4
9	Ao8	Analog	O	10bit D/A converter output terminal (CH8)	4
10	V <sub>DD</sub>	Analog	–	D/A converter upper reference voltage input terminal	5
11	V <sub>CC</sub>	–	–	Power supply terminal	–
12	Ao9	Analog	O	10bit D/A converter output terminal (CH9)	4
13	Ao10	Analog	O	10bit D/A converter output terminal (CH10)	4
14	D <sub>0</sub>	Digital	O	Terminal to output LSB data of 14-bit shift register	3
15	LD	Digital	I	When H-level signal is input to this terminal, the value stored in 14-bit shift register is loaded in decoder and D/A converter output register.	1
16	CLK	Digital	I	Shift clock input terminal. Input signal at DI pin is input to 14-bit shift register at rise of shift clock pulse	1
17	DI	Digital	I	Serial data input terminal to input 14-bit long serial data	1
18	Ao1	Analog	O	10bit D/A converter output terminal (CH1)	4
19	Ao2	Analog	O	10bit D/A converter output terminal (CH2)	4
20	GND	–	–	GND terminal	–

## ●External dimensions (Unit : mm)

