

22-bit GTL Processor Voltage Clamp

GTL2000

FEATURES

- Direct interface with TTL level
- 6.5Ω ON-state connection between port S_n and D_n

DESCRIPTION

The GTL2000 provides twenty-two bits of high-speed voltage clamps. The low ON-state resistance of the clamp allows connections to be made with minimal propagation delay.

The device is organized as one 22-bit voltage clamp. When S or D is low the clamp is in the ON-state and a low resistance connection exists between the S and D ports. When S port and D port are high, the clamp is in the OFF-state and a very high impedance exists between the S and D ports. When the D port is high, the voltage on the S port is clamped to the applied reference voltage on the GREF port.

PIN CONFIGURATION

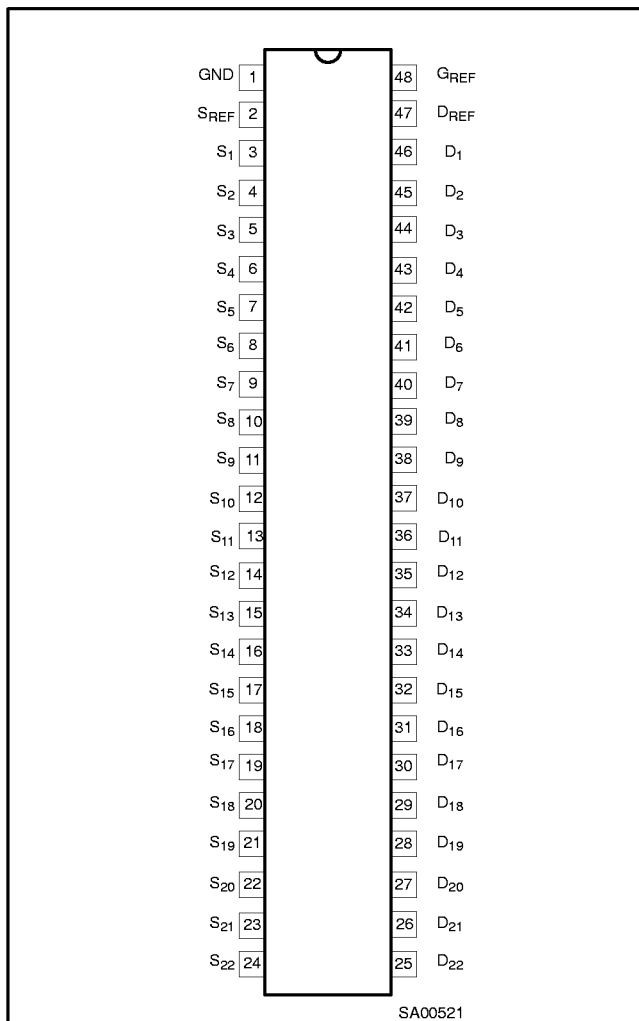

QUICK REFERENCE DATA

SYMBOL	PARAMETER	CONDITIONS	TYPICAL	UNIT
		T _{amb} = 25°C; GND = 0V		
t _{PLH}	Propagation delay S _n to D _n	V _{DD1} = 3.3V; V _{DD2} = 2.5V; V _{REF} = 1.5V; unloaded	1.5	ns
C _{OFF}	Channel capacitance (OFF-state)	V _S = 1.5V	7.5	pF

ORDERING INFORMATION

PACKAGES	TEMPERATURE RANGE	OUTSIDE NORTH AMERICA	NORTH AMERICA	DWG NUMBER
48-Pin Plastic SSOP Type II	0°C to +85°C	GTL2000 DB	GTL2000 DB	SOT370-1

22-bit GTL Processor Voltage Clamp

GTL2000

PIN DESCRIPTION

PIN NUMBER	SYMBOL	NAME AND FUNCTION
1	GND	Ground (0V)
2	S _{REF}	Source of reference transistor
3 – 24	S _n	Port S ₁ to Port S ₂₂
25 – 46	D _n	Port D ₁ to Port D ₂₂
47	D _{REF}	Drain of reference transistor
48	G _{REF}	Gate of reference transistor

FUNCTION TABLE

S _N	D _N
L	L
H	H

H = High voltage level
 L = Low voltage level
 Z = High impedance "off" state

CLAMP SCHEMATIC

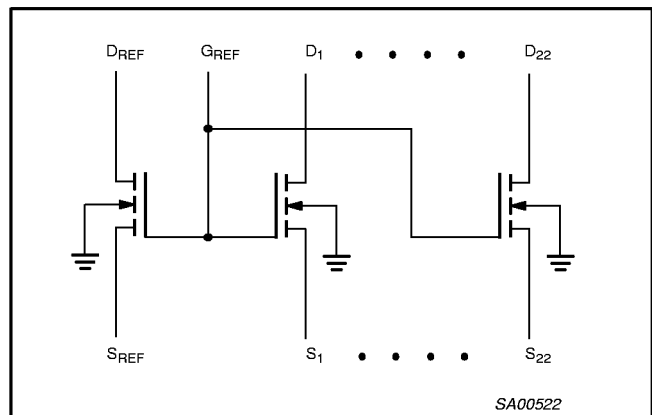

ABSOLUTE MAXIMUM RATINGS^{1, 2, 3}

SYMBOL	PARAMETER	CONDITIONS	RATING	UNIT
V _{S_REF}	DC source reference voltage		-0.5 to +7.0	V
V _{D_REF}	DC drain reference voltage		-0.5 to +7.0	V
V _{G_REF}	DC gate reference voltage		-0.5 to +7.0	V
V _{S_n}	DC voltage Port S _n		-0.5 to +7.0	V
V _{D_n}	DC voltage Port D _n		-0.5 to +7.0	V
I _{REFK}	DC reference diode current	V _I < 0	-50	mA
I _{SK}	DC diode current Port S _n	V _I < 0	-50	mA
I _{DK}	DC diode current Port D _n	V _I < 0	-50	mA
I _{MAX}	DC clamp current per channel	Channel in ON-state	±35	mA
T _{stg}	Storage temperature range		-65 to +150	°C

NOTE:

- Stresses beyond those listed may cause permanent damage to the device. These are stress ratings only and functional operation of the device at these or any other conditions beyond those indicated under "recommended operating conditions" is not implied. Exposure to absolute-maximum-rated conditions for extended periods may affect device reliability.
- The performance capability of a high-performance integrated circuit in conjunction with its thermal environment can create junction temperatures which are detrimental to reliability. The maximum junction temperature of this integrated circuit should not exceed 150°C.
- The input and output negative voltage ratings may be exceeded if the input and output clamp current ratings are observed.

22-bit GTL Processor Voltage Clamp

GTL2000

RECOMMENDED OPERATING CONDITIONS

SYMBOL	PARAMETER	CONDITIONS	LIMITS		UNIT
			Min	Max	
V _{S_REF}	DC source reference voltage		1.0	4.4	V
V _{D_REF}	DC drain reference voltage		V _{S_REF} + 0.6	5	V
V _{G_REF}	DC gate reference voltage		V _{S_REF} + 0.6	5	V
V _{Sn}	DC voltage Port S _n (OFF-state)		V _{S_REF}	5	V
V _{Sn}	DC voltage Port S _n (ON-state)		0	0.2	V
V _{Dn}	DC voltage Port D _n (OFF-state)		V _{S_REF}	5	V
V _{Dn}	DC voltage Port D _n (ON-state)		0	0.4	V
I _S	Switch input leakage current (OFF-state) for S _n and D _n I/O	V _S , V _D = 5V		15	μA
I _I	G _{REF} input leakage current	V _G = 5V		2.5	μA
T _{amb}	Operating ambient temperature range	In free air	0	+85	°C

DC CHARACTERISTICS for V_{DD1} = 3.0 to 3.6V; V_{DD2} = 2.36 to 2.64V; V_{REF} = 1.365 to 1.635V range

Over recommended operating conditions. Voltage are referenced to GND (ground = 0V). Refer to the Test Circuit diagram.

SYMBOL	PARAMETER	TEST CONDITIONS	LIMITS			UNIT
			T _{amb} = 0°C to +85°C			
			Min	Typ ¹	Max	
V _{OL}	LOW level output voltage	V _S = 0.175V; I _{CLAMP} = 15.2mA		260	350	mV

NOTE:

1. All typical values are measured at V_{DD1} = 3.3V, V_{DD2} = 2.5V, V_{REF} = 1.5V and T_{amb} = 25 C

AC CHARACTERISTICS for V_{DD1} = 3.0 to 3.6V; V_{DD2} = 2.36 to 2.64V; V_{REF} = 1.365 to 1.635V range

GND = 0V; t_r = t_f ≤ 3.0ns Refer to the Test Circuit diagram.

SYMBOL	PARAMETER	WAVEFORM	LIMITS			UNIT
			T _{amb} = 0 to +85°C			
			MIN	TYP ¹	MAX	
t _{PLH} ²	Propagation delay Sn to Dn; Dn to Sn		0.5	1.5	5.5	ns

NOTE:

1. All typical values are measured at V_{DD1} = 3.3V, V_{DD2} = 2.5V, V_{REF} = 1.5V and T_{amb} = 25 C
2. Propagation delay guaranteed by characterization
3. C_{ON,MAX} of 30pF and a C_{OFF,MAX} of 15pF is guaranteed by design

22-bit GTL Processor Voltage Clamp

GTL2000

AC WAVEFORMS

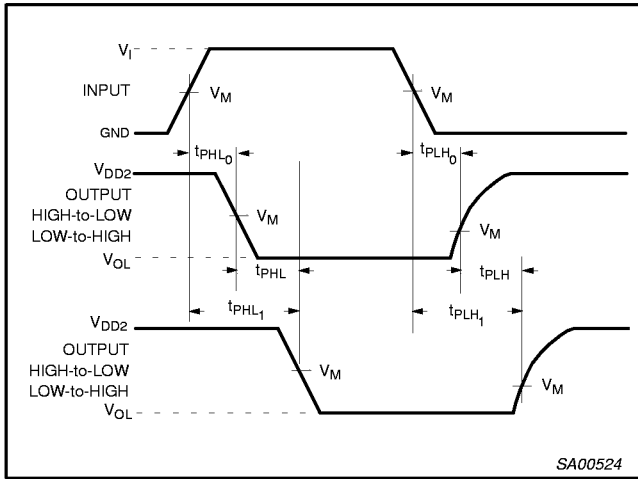

Waveform 1. The Input (S_n) to Output (D_n) Propagation Delays

TEST CIRCUIT

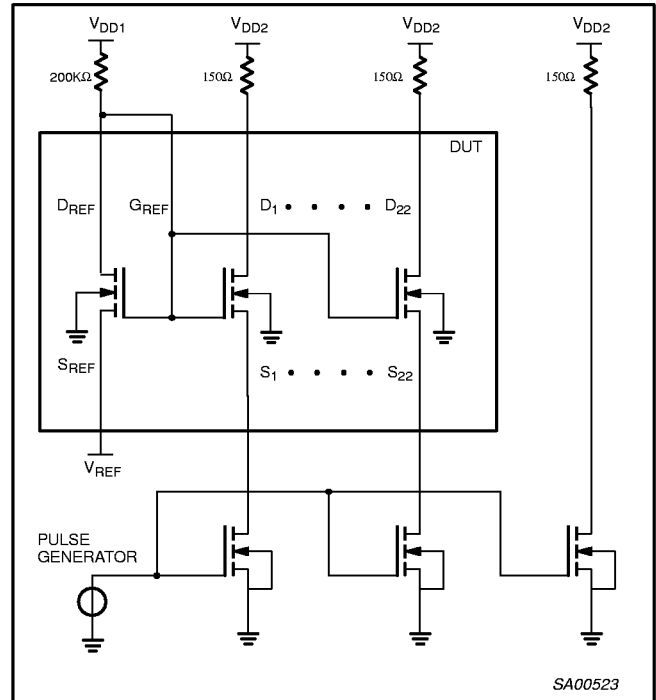

Waveform 2. Load circuit

22-bit GTL Processor Voltage Clamp

GTL2000

SSOP48: plastic shrink small outline package; 48 leads; body width 7.5 mm

SOT370-1

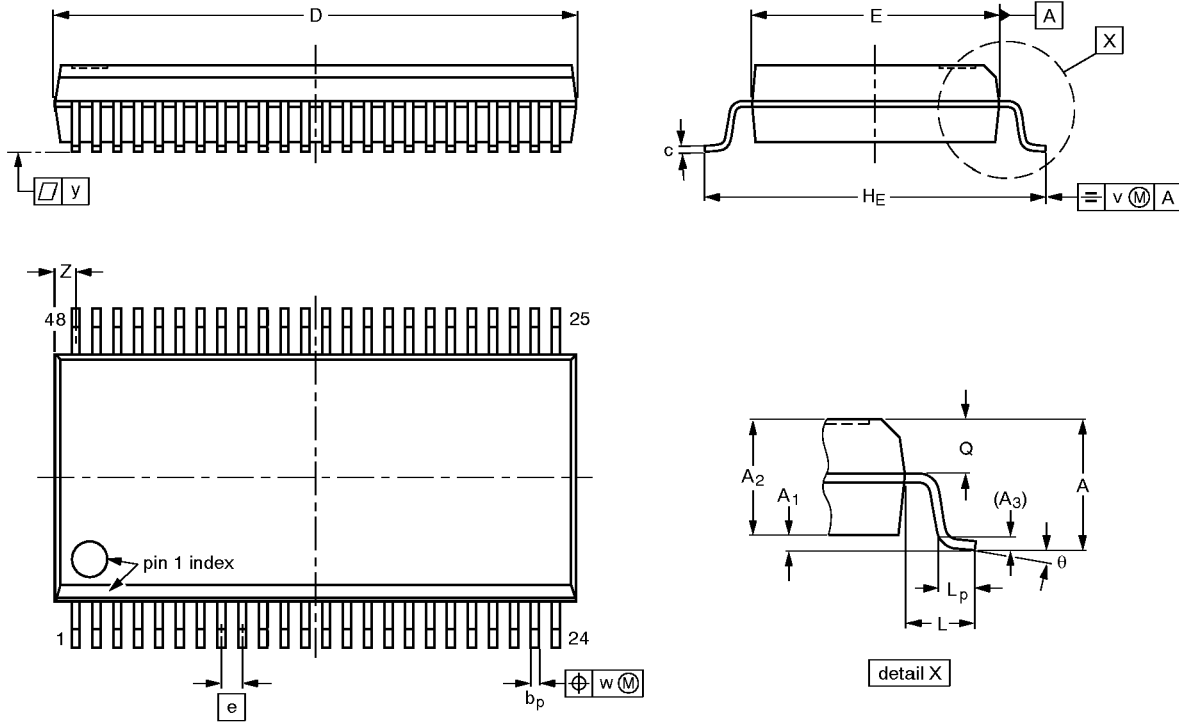

DIMENSIONS (mm are the original dimensions)

UNIT	A max.	A ₁	A ₂	A ₃	b _p	c	D ⁽¹⁾	E ⁽¹⁾	e	H _E	L	L _p	Q	v	w	y	Z ⁽¹⁾	θ
mm	2.8	0.4 0.2	2.35 2.20	0.25	0.3 0.2	0.22 0.13	16.00 15.75	7.6 7.4	0.635	10.4 10.1	1.4	1.0 0.6	1.2 1.0	0.25	0.18	0.1	0.85 0.40	8° 0°

Note

1. Plastic or metal protrusions of 0.25 mm maximum per side are not included.

OUTLINE VERSION	REFERENCES				EUROPEAN PROJECTION	ISSUE DATE
	IEC	JEDEC	EIAJ			
SOT370-1		MO-118AA				93-11-02 95-02-04

22-bit GTL Processor Voltage Clamp

GTL2000

NOTES

22-bit GTL Processor Voltage Clamp

GTL2000

Data sheet status

Data sheet status	Product status	Definition [1]
Objective specification	Development	This data sheet contains the design target or goal specifications for product development. Specification may change in any manner without notice.
Preliminary specification	Qualification	This data sheet contains preliminary data, and supplementary data will be published at a later date. Philips Semiconductors reserves the right to make changes at any time without notice in order to improve design and supply the best possible product.
Product specification	Production	This data sheet contains final specifications. Philips Semiconductors reserves the right to make changes at any time without notice in order to improve design and supply the best possible product.

[1] Please consult the most recently issued datasheet before initiating or completing a design.

Definitions

Short-form specification — The data in a short-form specification is extracted from a full data sheet with the same type number and title. For detailed information see the relevant data sheet or data handbook.

Limiting values definition — Limiting values given are in accordance with the Absolute Maximum Rating System (IEC 134). Stress above one or more of the limiting values may cause permanent damage to the device. These are stress ratings only and operation of the device at these or at any other conditions above those given in the Characteristics sections of the specification is not implied. Exposure to limiting values for extended periods may affect device reliability.

Application information — Applications that are described herein for any of these products are for illustrative purposes only. Philips Semiconductors make no representation or warranty that such applications will be suitable for the specified use without further testing or modification.

Disclaimers

Life support — These products are not designed for use in life support appliances, devices or systems where malfunction of these products can reasonably be expected to result in personal injury. Philips Semiconductors customers using or selling these products for use in such applications do so at their own risk and agree to fully indemnify Philips Semiconductors for any damages resulting from such application.

Right to make changes — Philips Semiconductors reserves the right to make changes, without notice, in the products, including circuits, standard cells, and/or software, described or contained herein in order to improve design and/or performance. Philips Semiconductors assumes no responsibility or liability for the use of any of these products, conveys no license or title under any patent, copyright, or mask work right to these products, and makes no representations or warranties that these products are free from patent, copyright, or mask work right infringement, unless otherwise specified.

Philips Semiconductors
811 East Arques Avenue
P.O. Box 3409
Sunnyvale, California 94088-3409
Telephone 800-234-7381

© Copyright Philips Electronics North America Corporation 1998
All rights reserved. Printed in U.S.A.

print code

Date of release: 10-98

Document order number:

9397-750-05521

Let's make things better.