

### FEATURES

- ❑ Octal Register with Additional 8-bit Shiftable Shadow Register
- ❑ Serial Load/Verify of Writable Control Store RAM
- ❑ Serial Stimulus/Observation of Sequential Logic
- ❑ High-Speed, Low Power CMOS Technology
- ❑ Replaces AMD Am29818
- ❑ DECC SMD No. 5962-90515
- ❑ Available 100% Screened to MIL-STD-883, Class B
- ❑ Package Styles Available:
  - 24-pin Plastic DIP
  - 24-pin Sidebraze, Hermetic DIP
  - 28-pin Ceramic LCC

### DESCRIPTION

The L29C818 is a high-speed octal register designed especially for applications using serial-scan diagnostics or writable control store. It is pin and functionally compatible with the AMD Am29818 bipolar device.

The L29C818 consists of an octal register, the P register, internally connected to an 8-bit shift register, the S register. Each has its own corresponding clock pin and the P register has a three-state output control.

An input control signal, MODE, in combination with the S register serial data input (SDI) pin controls data routing within the L29C818. When the MODE input is LOW, indicating normal operation, data present on the D7-0 pins is loaded into the P register on the rising edge of CLK P. The contents of the P register are visible on the output pins Y7-0 when the  $\overline{OE}$  control line is LOW.

Also, data present on the SDI pin is loaded into the least significant position of the S register on the rising edge of CLK S. In this mode, the S register performs a right-shift operation with the contents of each bit position replaced by the value in the next least significant location. The value in S7 is shifted out on the serial data output (SDO) pin. The SDI and SDO pins allow serial connection of multiple L29C818 devices into a diagnostic loop. When MODE is LOW, the operation of the P and S registers are completely independent and no timing relationship is enforced between CLK P and CLK S.

When MODE is HIGH, the internal multiplexers route data between the S and P registers and the Y port. The contents of the S register are loaded into the P register on the rising edge of

### L29C818 Block Diagram

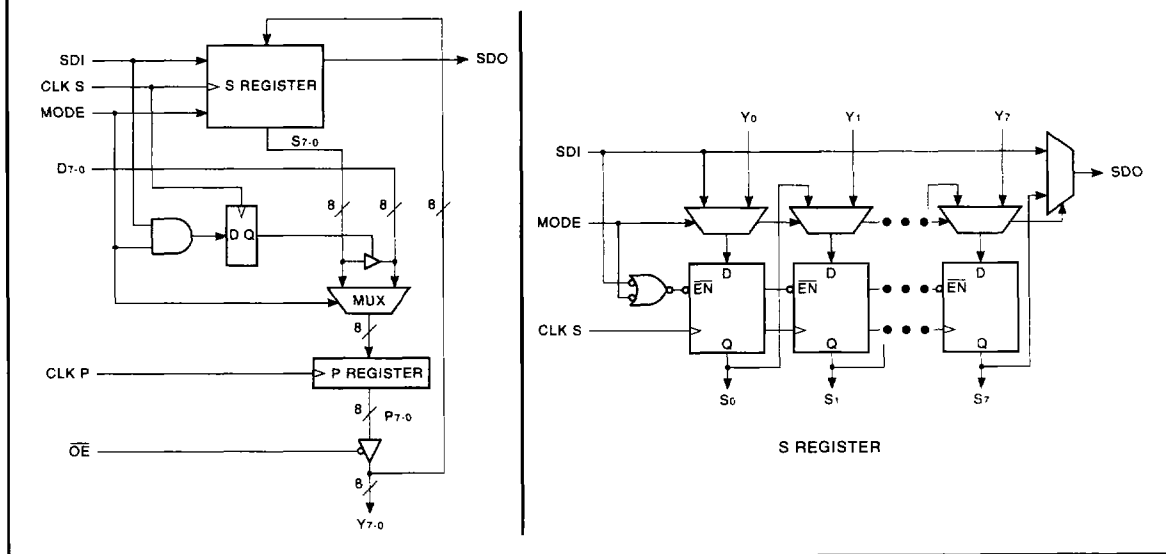

**8-bit Serial Scan Shadow Register**

CLK P. In diagnostic applications, this allows a data value input via serial scan to be loaded into the active data path of the machine.

When the MODE pin is HIGH, CLK S causes a parallel, rather than serial, load of the S register. In this mode, the S register is loaded from the Y7-0 pins at the rising edge of CLK S. This is useful in writable control store applications for read-back of the control store via the serial path.

When MODE is HIGH, the SDI pin is used as a control input to enable or disable the loading of the S register. It also affects routing of the S register contents onto the D7-0 outputs. When SDI is LOW, the S register is enabled for loading as above. When SDI is HIGH however, CLK S is prevented from reaching the S register and no load occurs. In order to allow the SDI pin to serve as an enable signal for all L29C818 devices in a serial configuration, special handling of the SDI input





is required. When MODE is HIGH, the SDI input drives the SDO output directly, bypassing the S register. This means that the SDI value will apply simultaneously to all L29C818s in a serial loop. However, to ensure proper operation of a given device, the user must ensure that the SDI setup time to CLK S is extended by the sum of the SDI to SDO delays of all previous devices in the serial path.

The D7-0 port is normally used as the input port to the D register. For writable control store applications however, this port is connected to the I/O pins of the RAM used as a control store. In order to load this RAM through the serial path, it is necessary to drive the S register contents onto the D7-0 pins. This is accomplished when MODE and SDI are HIGH and a CLK S rising edge occurs. Note from above that with SDI HIGH, no loading of the S register occurs. However, a flip-flop is set which synchronously enables the D port output buffer. The

D output remains enabled until the first rising edge of CLK S during which either SDI or MODE is LOW. Thus to load a control store RAM, data would be shifted in with MODE LOW. When an entire control store word is present in the serial S registers, the SDI and MODE pins are brought HIGH for one or more cycles, preventing further shifting of the S registers and enabling the contents onto the D port for writing into the RAM.

To verify the contents of a control store RAM, the RAM is read into the D register in the normal fashion. Then, the D contents are transferred in parallel to the S register by driving MODE HIGH with SDI LOW. The S register contents are then scanned out serially by returning MODE LOW and applying CLK S pulses.

**TABLE 1. FUNCTION TABLE**

Inputs				Outputs		Action		
MODE	SDI	CLK S	CLK P	P REG	S REG	Y7-0	D7-0	SDO
0	X		X	N/A	SHIFT	Normal	HI-Z	S7
0	X	X		LOAD D	N/A	Normal	Input	S7
1	0		X	N/A	LOAD Y	Input*	HI-Z	SDI
1	1		X	N/A	HOLD	Normal	Output	SDI
1	X	X		LOAD S	N/A	Normal	HI-Z	SDI

\*If  $\overline{OE}$  is LOW, the P register value will be loaded into the S register. If  $\overline{OE}$  is HIGH, a value may be applied externally to the Y7-0 pins.

## 8-bit Serial Scan Shadow Register

**MAXIMUM RATINGS** Above which useful life may be impaired (Notes 1, 2, 3, 8)

Storage temperature .....	-65°C to +150°C
Operating ambient temperature .....	-55°C to +125°C
VCC supply voltage with respect to ground .....	-0.5 V to +7.0 V
Input signal with respect to ground .....	-3.0 V to +7.0 V
Signal applied to high impedance output .....	-3.0 V to +7.0 V
Output current into low outputs .....	25 mA
Latchup current .....	> 400 mA

**OPERATING CONDITIONS** To meet specified electrical and switching characteristics

Mode	Temperature Range (Ambient)	Supply Voltage
Active Operation, Commercial	0°C to +70°C	4.75 V ≤ VCC ≤ 5.25 V
Active Operation, Military	-55°C to +125°C	4.50 V ≤ VCC ≤ 5.50 V

**5**
**ELECTRICAL CHARACTERISTICS** Over Operating Conditions (Note 4)

Symbol	Parameter	Test Condition	Min	Typ	Max	Unit
V <sub>OH</sub>	Output High Voltage	VCC = Min., I <sub>OH</sub> = -12.0 mA	2.4			V
V <sub>OL</sub>	Output Low Voltage	VCC = Min., I <sub>OL</sub> = 24.0 mA			0.5	V
V <sub>IH</sub>	Input High Voltage		2.0		VCC	V
V <sub>IL</sub>	Input Low Voltage	(Note 3)	0.0		0.8	V
I <sub>IX</sub>	Input Current	Ground ≤ V <sub>IN</sub> ≤ VCC (Note 12)			±20	μA
I <sub>OZ</sub>	Output Leakage Current	Ground ≤ V <sub>OUT</sub> ≤ VCC (Note 12)			±20	μA
I <sub>CC1</sub>	VCC Current, Dynamic	(Notes 5, 6)		10	15	mA
I <sub>CC2</sub>	VCC Current, Quiescent	(Note 7)			1.0	mA

**SWITCHING CHARACTERISTICS — NORMAL REGISTER OPERATION**
**COMMERCIAL OPERATING RANGE (0°C to +70°C) Notes 9, 10 (ns)**

Symbol	Parameter	L29C818-			
		25		15	
		Min	Max	Min	Max
tPWP	CLK P Pulse Width	15		10	
tPDY	CLK P to Y7-0		13		9
tSDP	D7-0 to CLK P Setup Time	8		6	
tHDP	CLK P to D7-0 Hold Time	2		2	
tSMP	MODE to CLK P Setup Time	15		15	
tHMP	CLK P to MODE Hold Time	2		2	
tENA	Three-State Output Enable Delay (Note 11)		25		25
tDIS	Three-State Output Disable Delay (Note 11)		15		15

**MILITARY OPERATING RANGE (-55°C to +125°C) Notes 9, 10 (ns)**

Symbol	Parameter	L29C818-			
		30		24	
		Min	Max	Min	Max
tPWP	CLK P Pulse Width	15		15	
tPDY	CLK P to Y7-0		18		12
tSDP	D7-0 to CLK P Setup Time	10		8	
tHDP	CLK P to D7-0 Hold Time	2		2	
tSMP	MODE to CLK P Setup Time	15		15	
tHMP	CLK P to MODE Hold Time	2		2	
tENA	Three-State Output Enable Delay (Note 11)		30		30
tDIS	Three-State Output Disable Delay (Note 11)		20		20

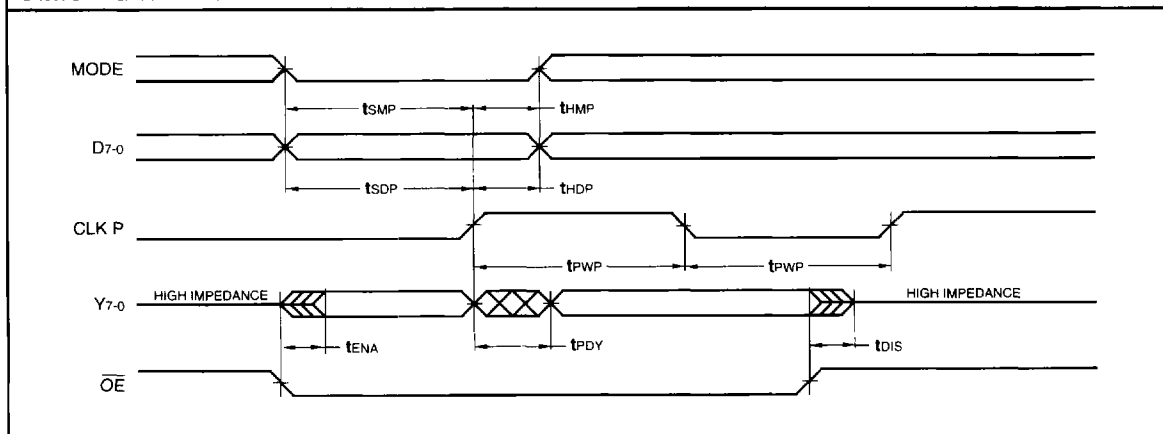
**SWITCHING WAVEFORMS — NORMAL REGISTER OPERATION**

**SWITCHING CHARACTERISTICS — SERIAL SHIFT OPERATION**

**COMMERCIAL OPERATING RANGE (0°C to +70°C) Notes 9, 10 (ns)**

Symbol	Parameter	L29C818-			
		25		15	
		Min	Max	Min	Max
t <sub>PWS</sub>	CLK S Pulse Width	25		15	
t <sub>DSSO</sub>	CLK S to SDO		25		25
t <sub>SSIS</sub>	SDI to CLK S Setup Time	10		10	
t <sub>HSSI</sub>	CLK S to SDI Hold Time	0		0	
t <sub>SMS</sub>	MODE to CLK S Setup Time	12		12	
t <sub>HSM</sub>	CLK S to MODE Hold Time	2		2	
t <sub>DMSO</sub>	MODE to SDO	16		16	
t <sub>DSISO</sub>	SDI to SDO	16		15	

**MILITARY OPERATING RANGE (-55°C to +125°C) Notes 9, 10 (ns)**

Symbol	Parameter	L29C818-			
		30		24	
		Min	Max	Min	Max
t <sub>PWS</sub>	CLK S Pulse Width	25		25	
t <sub>DSSO</sub>	CLK S to SDO		30		30
t <sub>SSIS</sub>	SDI to CLK S Setup Time	12		12	
t <sub>HSSI</sub>	CLK S to SDI Hold Time	0		0	
t <sub>SMS</sub>	MODE to CLK S Setup Time	12		12	
t <sub>HSM</sub>	CLK S to MODE Hold Time	5		5	
t <sub>DMSO</sub>	MODE to SDO	18		18	
t <sub>DSISO</sub>	SDI to SDO	18		18	

**5**

**SWITCHING WAVEFORMS — SERIAL SHIFT OPERATION**

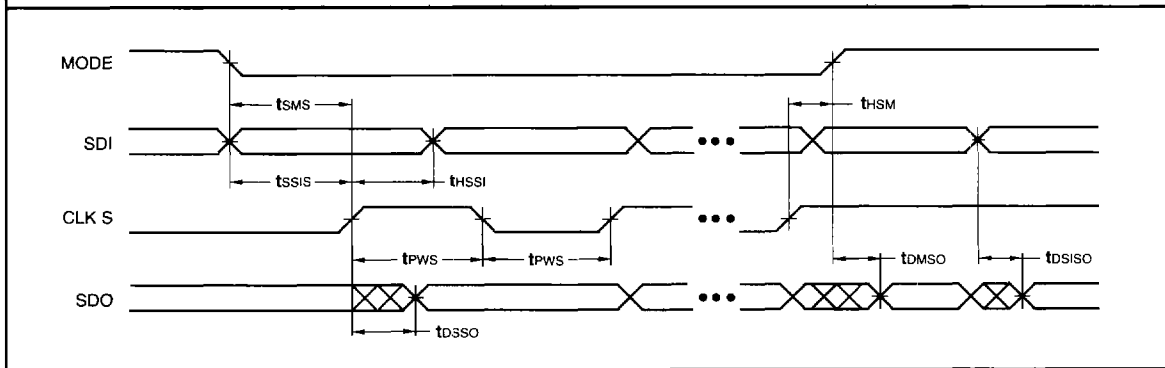

### SWITCHING CHARACTERISTICS — PIPELINE LOAD FROM SHADOW

**COMMERCIAL OPERATING RANGE (0°C to +70°C) Notes 9, 10 (ns)**

Symbol		Parameter		L29C818—			
				25		15	
				Min	Max	Min	Max
tSMP	MODE to CLK P	15		15			
tHPM	CLK P to MODE Hold Time	2		2			
tSSP	CLK S to CLK P	10		10			

**MILITARY OPERATING RANGE (-55°C to +125°C) Notes 9, 10 (ns)**

Symbol		Parameter		L29C818—			
				30		24	
				Min	Max	Min	Max
tSMP	MODE to CLK P	15		15			
tHPM	CLK P to MODE Hold Time	2		2			
tSSP	CLK S to CLK P	15		15			

### SWITCHING WAVEFORMS — PIPELINE LOAD FROM SHADOW

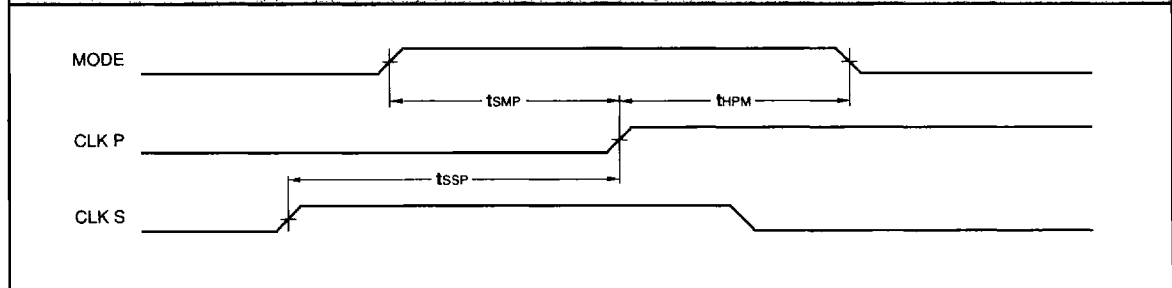

### SWITCHING CHARACTERISTICS — SHADOW LOAD FROM Y PORT

#### COMMERCIAL OPERATING RANGE (0°C to +70°C) Notes 9, 10 (ns)

Symbol		Parameter		L29C818-			
				25		15	
				Min	Max	Min	Max
t <sub>SY</sub>	Y7-0 to CLK S Setup Time	5		5			
t <sub>HSY</sub>	CLK S to Y7-0 Hold Time	5		5			
t <sub>SMS</sub>	MODE to CLK S Setup Time	12		12			
t <sub>HSM</sub>	CLK S to MODE Hold Time	2		2			
t <sub>SSIS</sub>	SDI to CLK S Setup Time	10		10			
t <sub>HSSI</sub>	CLK S to SDI Hold Time	0		0			

#### MILITARY OPERATING RANGE (-55°C to +125°C) Notes 9, 10 (ns)

Symbol		Parameter		L29C818-			
				30		24	
				Min	Max	Min	Max
t <sub>SY</sub>	Y7-0 to CLK S Setup Time	5		5			
t <sub>HSY</sub>	CLK S to Y7-0 Hold Time	5		5			
t <sub>SMS</sub>	MODE to CLK S Setup Time	12		12			
t <sub>HSM</sub>	CLK S to MODE Hold Time	5		5			
t <sub>SSIS</sub>	SDI to CLK S Setup Time	12		12			
t <sub>HSSI</sub>	CLK S to SDI Hold Time	0		0			

5

### SWITCHING WAVEFORMS — SHADOW LOAD FROM Y PORT

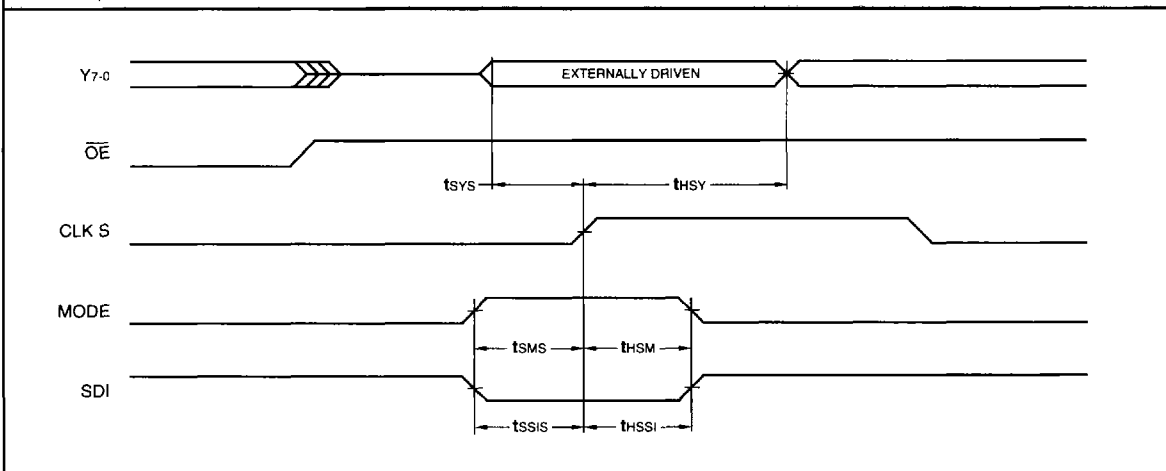

**SWITCHING CHARACTERISTICS — SHADOW READ VIA D PORT**
**COMMERCIAL OPERATING RANGE (0°C to +70°C) Notes 9, 10 (ns)**

Symbol		Parameter		L29C818-			
				25		15	
				Min	Max	Min	Max
tSMS	MODE to CLK S Setup Time	12		12			
tHSM	CLK S to MODE Hold Time	2		2			
tSSIS	SDI to CLK S Setup Time	10		10			
tHSSI	CLK S to SDI Hold Time	0		0			
tENAD	CLK S to D7-0 Enable Delay (Note 11)	85		80			
tDISD	CLK S to D7-0 Disable Delay (Note 11)	30		25			

**MILITARY OPERATING RANGE (-55°C to +125°C) Notes 9, 10 (ns)**

Symbol		Parameter		L29C818-			
				30		24	
				Min	Max	Min	Max
tSMS	MODE to CLK S Setup Time	12		12			
tHSM	CLK S to MODE Hold Time	5		5			
tSSIS	SDI to CLK S Setup Time	12		12			
tHSSI	CLK S to SDI Hold Time	0		0			
tENAD	CLK S to D7-0 Enable Delay (Note 11)	90		90			
tDISD	CLK S to D7-0 Disable Delay (Note 11)	35		35			

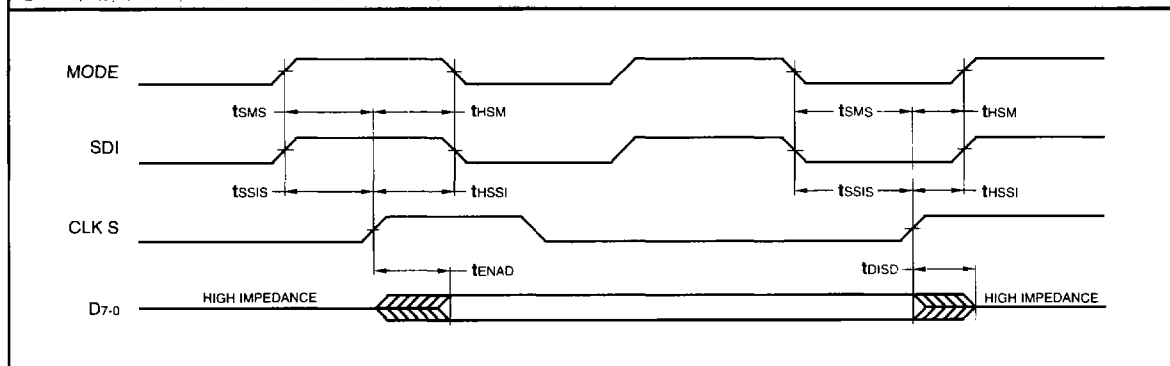
**SWITCHING WAVEFORMS — SHADOW READ VIA D PORT**

**NOTES**

1. Maximum Ratings indicate stress specifications only. Functional operation of these products at values beyond those indicated in the Operating Conditions table is not implied. Exposure to maximum rating conditions for extended periods may affect reliability.

2. The products described by this specification include internal circuitry designed to protect the chip from damaging substrate injection currents and accumulations of static charge. Nevertheless, conventional precautions should be observed during storage, handling, and use of these circuits in order to avoid exposure to excessive electrical stress values.

3. This device provides hard clamping of transient undershoot and overshoot. Input levels below ground or above VCC will be clamped beginning at  $-0.6\text{ V}$  and  $V_{CC} + 0.6\text{ V}$ . The device can withstand indefinite operation with inputs in the range of  $-0.5\text{ V}$  to  $+7.0\text{ V}$ . Device operation will not be adversely affected, however, input current levels will be well in excess of 100 mA.

4. Actual test conditions may vary from those designated but operation is guaranteed as specified.

5. Supply current for a given application can be accurately approximated by:

$$\frac{NCV^2F}{4}$$

where

- N = total number of device outputs
- C = capacitive load per output
- V = supply voltage
- F = clock frequency

6. Tested with all outputs changing every cycle and no load, at a 5 MHz clock rate.

7. Tested with all inputs within 0.1 V of VCC or Ground, no load.

8. These parameters are guaranteed but not 100% tested.

9. AC specifications are tested with input transition times less than 3 ns, output reference levels of 1.5 V (except tDIS test), and input levels of nominally 0 to 3.0 V. Output loading may be a resistive divider which provides for specified IOH and IOL at an output voltage of VOH min and VOL max respectively. Alternatively, a diode bridge with upper and lower current sources of IOH and IOL respectively, and a balancing voltage of 1.5 V may be used. Parasitic capacitance is 30 pF minimum, and may be distributed.

This device has high-speed outputs capable of large instantaneous current pulses and fast turn-on/turn-off times. As a result, care must be exercised in the testing of this device. The following measures are recommended:

a. A 0.1  $\mu\text{F}$  ceramic capacitor should be installed between VCC and Ground leads as close to the Device Under Test (DUT) as possible. Similar capacitors should be installed between device VCC and the tester common, and device ground and tester common.

b. Ground and VCC supply planes must be brought directly to the DUT socket or contactor fingers.

c. Input voltages should be adjusted to compensate for inductive ground and VCC noise to maintain required DUT input levels relative to the DUT ground pin.

10. Each parameter is shown as a minimum or maximum value. Input requirements are specified from the point of view of the external system driving the chip. Setup time, for example, is specified as a minimum since the external system must supply at least that much time to meet the worst-case requirements of all parts. Responses from the internal circuitry are specified from the point of view of the device. Output delay, for example, is specified as a maximum since worst-case operation of any device always provides data within that time.

11. For the tENA test, the transition is measured to the 1.5 V crossing point with datasheet loads. For the tDIS test, the transition is measured to the  $\pm 200\text{ mV}$  level from the measured steady-state output voltage with  $\pm 10\text{ mA}$  loads. The balancing voltage, VTH, is set at 3.5 V for Z-to-0 and 0-to-Z tests, and set at 0 V for Z-to-1 and 1-to-Z tests.

12. These parameters are only tested at the high temperature extreme, which is the worst case for leakage current.

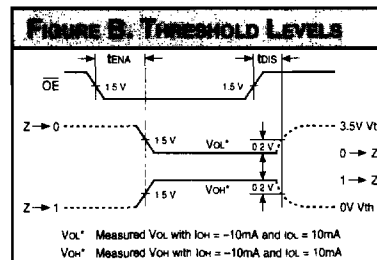
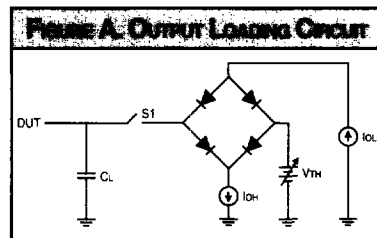

### 8-bit Serial Scan Shadow Register

#### ORDERING INFORMATION

24-pin — 0.3" wide

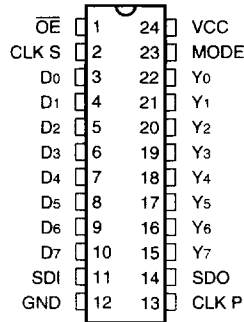

28-pin

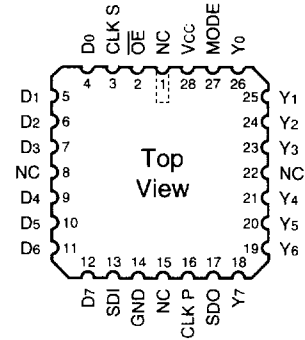

Speed	Plastic DIP (P2)	Sidebrazed Hermetic DIP (D2)	Ceramic Leadless Chip Carrier (K1)
<b>0°C to +70°C — COMMERCIAL SCREENING</b>			
25 ns 15 ns	L29C818PC25 L29C818PC15		
<b>-55°C to +125°C — COMMERCIAL SCREENING</b>			
30 ns 24 ns			
<b>-55°C to +125°C — MIL-STD-883 COMPLIANT</b>			
30 ns 24 ns		L29C818DMB30 L29C818DMB24	L29C818KMB30 L29C818KMB24