

ZMM55-C2V4 SERIES

SURFACE MOUNT ZENER DIODES

VOLTAGE 2.4 to 100 Volts

POWER 500 mWatts

MINI-MELF/LL-34

Unit : inch (mm)

FEATURES

- Planar Die construction
- 500mW Power Dissipation
- Ideally Suited for Automated Assembly Processes
- Lead free in comply with EU RoHS 2002/95/EC directives

MECHANICAL DATA

- Case: Molded Glass MINI-MELF
- Terminals: Solderable per MIL-STD-750, Method 2026
- Polarity: See Diagram Below
- Approx. Weight: 0.03 grams
- Mounting Position: Any
- Packing information

T/R - 2.5K per 7" plastic Reel

T/R - 10K per 13" plastic Reel

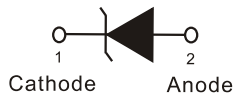
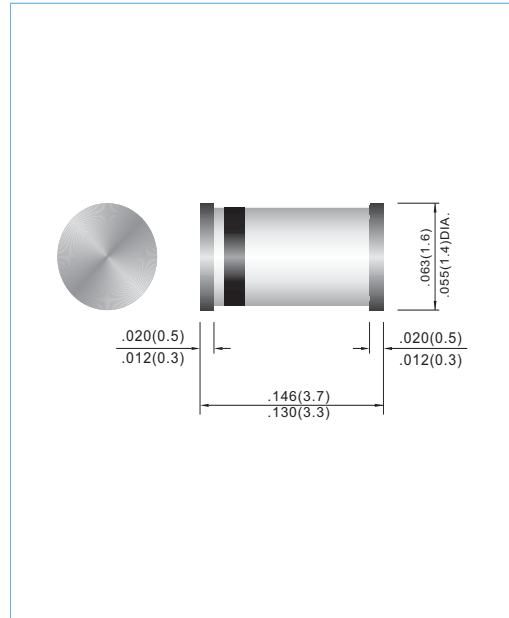

MAXIMUM RATINGS AND ELECTRICAL CHARACTERISTICS

Parameter	Symbol	Value	Units
Power Dissipation at $T_{amb} = 25\text{ }^{\circ}\text{C}$	P_{TOT}	500	mW
Junction Temperature	T_J	175	$^{\circ}\text{C}$
Storage Temperature Range	T_S	-65 to +175	$^{\circ}\text{C}$

Valid provided that leads at a distance of 8mm from case are kept at ambient temperature.

Parameter	Symbol	Min.	Typ.	Max.	Units
Thermal Resistance Junction to Ambient Air	$R_{\theta JA}$	--	--	0.3	K/mW
Forward Voltage at $I_F = 200\text{mA}$	V_F	--	--	1.5	V

Valid provided that leads at a distance of 8mm from case are kept at ambient temperature.

ZMM55-C2V4 SERIES

Part Number	Nominal Zener Voltage			Max. Zener Impedance				Max Reverse Leakage Current		Marking code
	Vz @ IzT			ZzT @ IzT		Zzk @ Izk		IR @ VR		
	Nom. V	Min. V	Max. V	Ω	mA	Ω	mA	uA	V	
ZMM55-C2V4	2.4	2.28	2.56	85	5	600	1	50	1	C2V4
ZMM55-C2V7	2.7	2.5	2.9	85	5	600	1	10	1	C2V7
ZMM55-C3V0	3	2.8	3.2	85	5	600	1	4	1	C3V0
ZMM55-C3V3	3.3	3.1	3.5	85	5	600	1	2	1	C3V3
ZMM55-C3V6	3.6	3.4	3.8	85	5	600	1	2	1	C3V6
ZMM55-C3V9	3.9	3.7	4.1	85	5	600	1	2	1	C3V9
ZMM55-C4V3	4.3	4	4.6	75	5	600	1	1	1	C4V3
ZMM55-C4V7	4.7	4.4	5	60	5	600	1	0.5	1	C4V7
ZMM55-C5V1	5.1	4.8	5.4	35	5	550	1	0.1	1	C5V1
ZMM55-C5V6	5.6	5.2	6	25	5	450	1	0.1	1	C5V6
ZMM55-C6V2	6.2	5.8	6.6	10	5	200	1	0.1	2	C6V2
ZMM55-C6V8	6.8	6.4	7.2	8	5	150	1	0.1	3	C6V8
ZMM55-C7V5	7.5	7	7.9	7	5	50	1	0.1	5	C7V5
ZMM55-C8V2	8.2	7.7	8.7	7	5	50	1	0.1	6	C8V2
ZMM55-C9V1	9.1	8.5	9.6	10	5	50	1	0.1	7	C9V1
ZMM55-C10	10	9.4	10.6	15	5	70	1	0.1	7.5	C10V
ZMM55-C11	11	10.4	11.6	20	5	70	1	0.1	8.5	C11V
ZMM55-C12	12	11.4	12.7	20	5	90	1	0.1	9	C12V
ZMM55-C13	13	12.4	14.1	26	5	110	1	0.1	10	C13V
ZMM55-C15	15	13.8	15.6	30	5	110	1	0.1	11	C15V
ZMM55-C16	16	15.3	17.1	40	5	170	1	0.1	12	C16V
ZMM55-C18	18	16.8	19.1	50	5	170	1	0.1	14	C18V
ZMM55-C20	20	18.8	21.2	55	5	220	1	0.1	15	C20V
ZMM55-C22	22	20.8	23.3	55	5	220	1	0.1	17	C22V
ZMM55-C24	24	22.8	25.6	80	5	220	1	0.1	18	C24V
ZMM55-C27	27	25.1	28.9	80	5	220	1	0.1	20	C27V
ZMM55-C30	30	28	32	80	5	220	1	0.1	22	C30V
ZMM55-C33	33	31	35	80	5	220	1	0.1	24	C33V
ZMM55-C36	36	34	38	80	5	220	1	0.1	27	C36V
ZMM55-C39	39	37	41	90	2.5	500	1	0.1	30	C39V
ZMM55-C43	43	40	46	90	2.5	600	1	0.1	33	C43V
ZMM55-C47	47	44	50	110	2.5	700	1	0.1	36	C47V
ZMM55-C51	51	48	54	125	2.5	700	0.5	0.1	39	C51V
ZMM55-C56	56	52	60	135	2.5	1000	0.5	0.1	43	C56V
ZMM55-C62	62	58	66	150	2.5	1000	0.5	0.1	47	C62V
ZMM55-C68	68	64	72	200	2.5	1000	0.5	0.1	51	C68V
ZMM55-C75	75	70	79	250	2.5	1500	0.5	0.1	56	C75V
ZMM55-C82	82	77	87	300	2.5	2000	0.5	0.1	62	C82V
ZMM55-C91	91	85	96	450	1	5000	0.1	0.1	68	C91V
ZMM55-C100	100	94	106	450	1	5000	0.1	0.1	75	C100

Notes.

STANDARD VOLTAGE TOLERANCE IS $\pm 5\%$ AND :

SUFFIX "A" FOR $\pm 1\%$

SUFFIX "B" FOR $\pm 2\%$

SUFFIX "C" FOR $\pm 5\%$

SUFFIX "D" FOR $\pm 20\%$

ZMM55-C2V4 SERIES

RATING AND CHARACTERISTIC CURVES

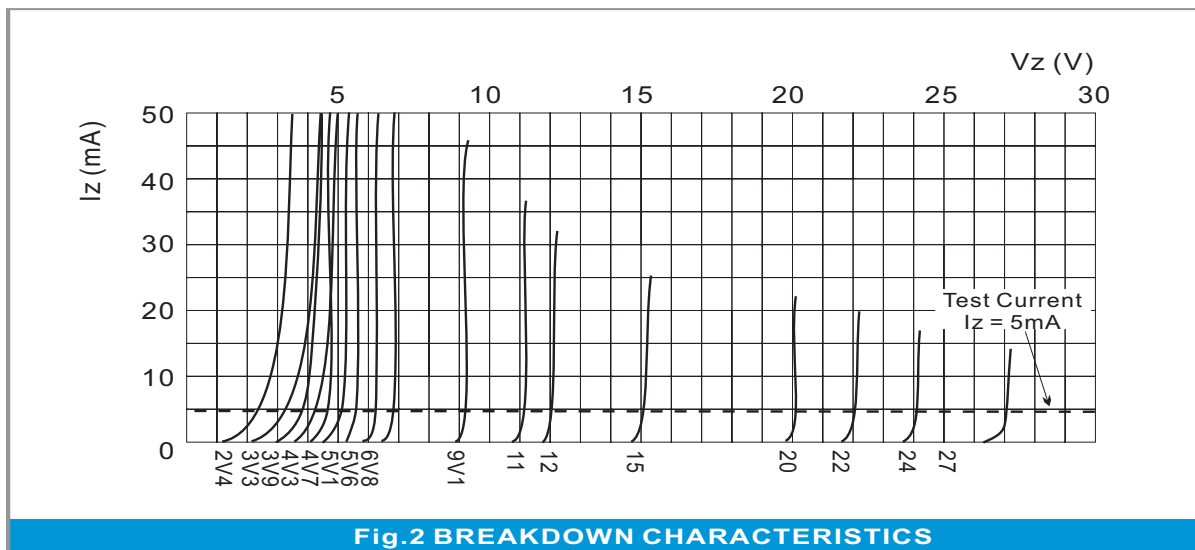
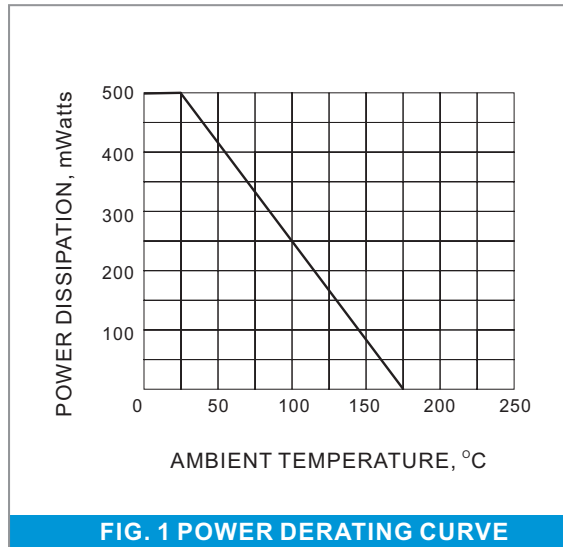

ZMM55-C2V4 SERIES

MOUNTING PAD LAYOUT

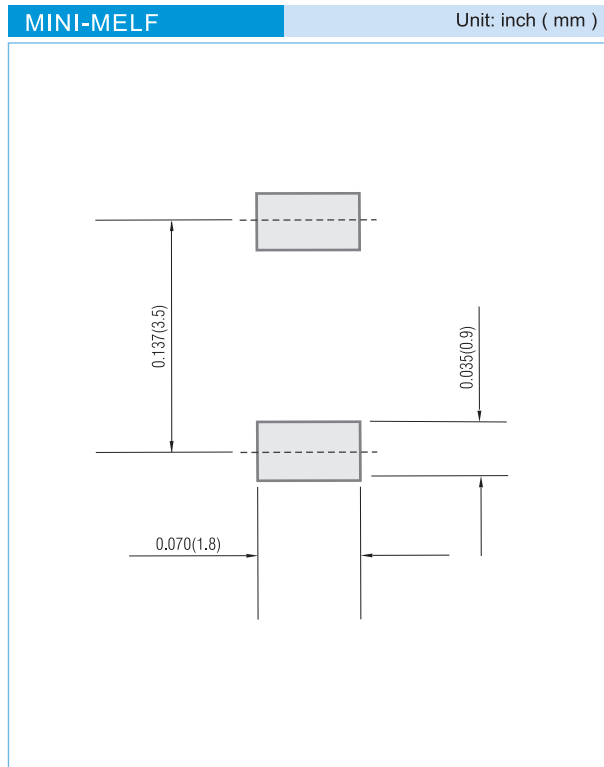

ORDER INFORMATION

- Packing information
 - T/R - 10K per 13" plastic Reel
 - T/R - 2.5K per 7" plastic Reel

ZMM55-C2V4 SERIES

Part No_packing code_Version

ZMM55-C2V4_R1_10001

ZMM55-C2V4_R2_10001

For example :

RB500V-40_R2_00001



Packing Code XX				Version Code XXXXX		
Packing type	1 st Code	Packing size code	2 nd Code	HF or RoHS	1 st Code	2 nd ~5 th Code
Tape and Ammunition Box (T/B)	A	N/A	0	HF	0	serial number
Tape and Reel (T/R)	R	7"	1	RoHS	1	serial number
Bulk Packing (B/P)	B	13"	2			
Tube Packing (T/P)	T	26mm	X			
Tape and Reel (Right Oriented) (TRR)	S	52mm	Y			
Tape and Reel (Left Oriented) (TRL)	L	PANASERT T/B CATHODE UP (PBCU)	U			
FORMING	F	PANASERT T/B CATHODE DOWN (PBCD)	D			

ZMM55-C2V4 SERIES

Disclaimer

- Reproducing and modifying information of the document is prohibited without permission from Panjit International Inc..
- Panjit International Inc. reserves the rights to make changes of the content herein the document anytime without notification. Please refer to our website for the latest document.
- Panjit International Inc. disclaims any and all liability arising out of the application or use of any product including damages incidentally and consequentially occurred.
- Panjit International Inc. does not assume any and all implied warranties, including warranties of fitness for particular purpose, non-infringement and merchantability.
- Applications shown on the herein document are examples of standard use and operation. Customers are responsible in comprehending the suitable use in particular applications. Panjit International Inc. makes no representation or warranty that such applications will be suitable for the specified use without further testing or modification.
- The products shown herein are not designed and authorized for equipments requiring high level of reliability or relating to human life and for any applications concerning life-saving or life-sustaining, such as medical instruments, transportation equipment, aerospace machinery et cetera. Customers using or selling these products for use in such applications do so at their own risk and agree to fully indemnify Panjit International Inc. for any damages resulting from such improper use or sale.