

Fast Infrared Transceiver Module Family (FIR, 4 Mbit/s) for 2.6 V to 5.5 V Operation



Description

The TFDH6131 and TFDH6541 transceivers are package modification inside the 6000E – family of low-power infrared transceiver modules compliant to the IrDA physical layer standard for fast infrared data communication, supporting IrDA speeds up to 4 Mbit/s (FIR), HP-SIR, Sharp ASK and carrier based remote control modes up to 2 MHz. Integrated within the transceiver modules are a photo PIN diode, an infrared emitter (IRED), and a low-power CMOS control IC to provide a total front-end solution in a single package.

Vishay Telefunken's through hole package FIR transceivers are available in two package options. One

is based on the standard package with the leads single in line (SIL), the other based on the BabyFace package, leads dual in line. The transceivers are capable of directly interfacing with a wide variety of I/O devices which perform the modulation/ demodulation function, including National Semiconductor's PC87338, PC87108 and PC87109, SMC's FDC37C669, FDC37N769 and CAM35C44, and Hitachi's SH3. At a minimum, a current-limiting resistor in series with the infrared emitter and a V_{CC} bypass capacitor are the only external components required implementing a complete solution.

Features

- Compliant to the latest IrDA physical layer standard, (FIR 4 Mbit/s, full range), HP-SIR[®], Sharp ASK[®] and TV Remote Control
- For 3.0 V and 5.0 V Applications
- Operates from 2.6 V to 5.5 V within specification, operational down to 2.4 V
- Low Power Consumption (3 mA Supply Current)
- Power Shutdown Mode (1 μ A Shutdown Current)
- Two Surface Mount Package Options
 - Side View (13.0 \times 5.95 \times 4.3 mm)
 - Side View (9.7 \times 4.7 \times 4.0 mm)
- Push-Pull-Receiver Output, grounded in shutdown mode for device identification
- High Efficiency Emitter
- Directly Interfaces with Various Super I/O and Controller Devices
- Built-In EMI Protection – No External Shielding Necessary
- Few External Components Required
- Split power supply, transmitter and receiver can be operated from two power supplies with relaxed requirements saving costs, covered by US Patent 08995536

Applications

- Notebook Computers, Desktop PCs, Palmtop Computers (Win CE, Palm PC), PDAs
- Printers, Fax Machines, Photocopiers, Screen Projectors
- Internet TV Boxes, Video Conferencing Systems
- External Infrared Adapters (Dongles)
- Medical and Industrial Data Collection

Package Options

TFDH6131
Side View
Through Hole DIL

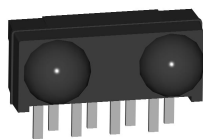

TFDH6541
Side View
Through Hole SIL

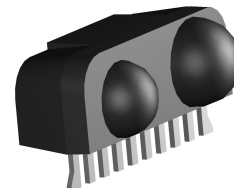

Ordering Information

Part Number	Qty / Reel or Tube	Description
TFDH6131	55/ tube	Side View, 40 tubes per box
TFDH6541	40/ tube	Side View, 40 tubes per box

Functional Block Diagram

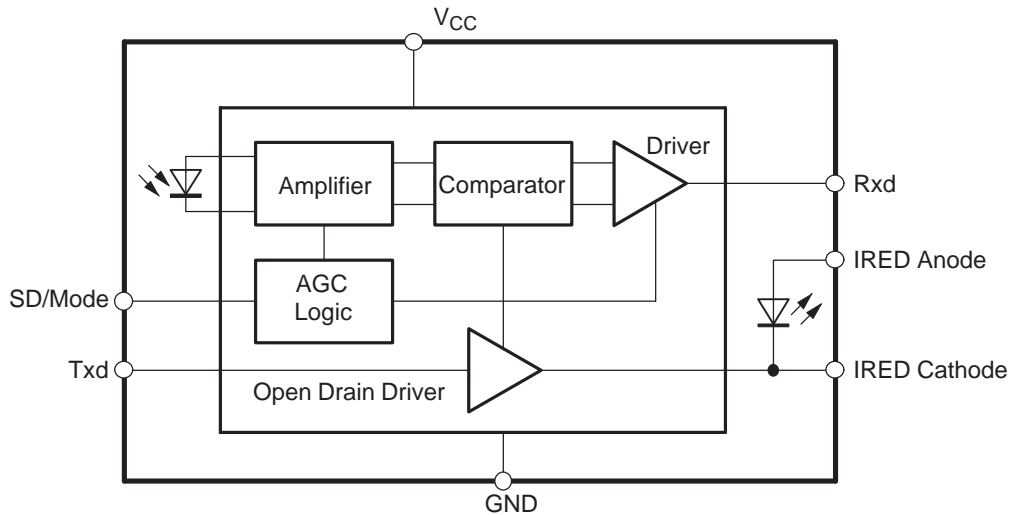
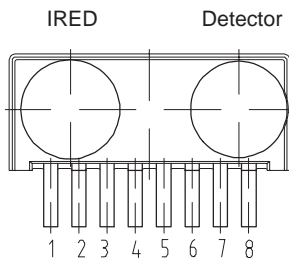

Figure 1. Functional Block Diagram

Pin Description

Pin Number	Function	Description	I/O	Active
1	IRED Anode	IRED anode, to be externally connected to V_{CC} through a current control resistor. This pin is allowed to be supplied from an uncontrolled power supply separated from the controlled V_{CC} supply		
2	IRED Cathode	IRED cathode, internally connected to driver transistor		
3	Txd	Transmit Data Input	I	HIGH
4	Rxd	Pin is switched to ground when device is in shutdown mode	O	LOW
5	SD/Mode	Shutdown/ Mode	I	HIGH
6	V_{CC}	Supply Voltage		
7	Mode	HIGH: High speed mode; LOW: Low speed mode, SIR only (see chapter "Mode Switching")	I	
8	GND	Ground		

"H" Option BabyFace Side View



"H" Option Side View

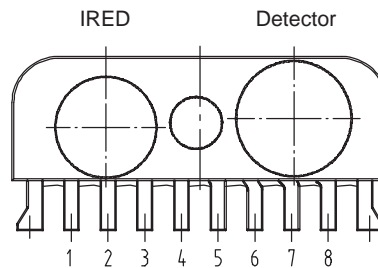

Figure 2. Pinnings



Absolute Maximum Ratings

Reference point Pin: GND unless otherwise noted.

Typical values are for DESIGN AID ONLY, not guaranteed nor subject to production testing.

Parameters	Test Conditions	Symbol	Min.	Typ.	Max.	Unit
Supply Voltage Range, Transceiver	$0\text{ V} < V_{CC2} < 6\text{ V}$	V_{CC1}	-0.5		6	V
Supply Voltage Range, Transmitter	$0\text{ V} < V_{CC1} < 6\text{ V}$	V_{CC2}	-0.5		6	V
Input Currents	For all Pins, Except IRED Anode Pin				10	mA
Output Sinking Current					25	mA
Power Dissipation	See Derating Curve	P_D			350	mW
Junction Temperature		T_J			125	°C
Ambient Temperature Range (Operating)		T_{amb}	-25		+85	°C
Storage Temperature Range		T_{stg}	-25		+85	°C
Soldering Temperature	$t < 0.65$				360	°C
Average Output Current		$I_{IRED} (DC)$			130	mA
Repetitive Pulsed Output Current	$< 90\text{ }\mu\text{s}$, $t_{on} < 20\%$	$I_{IRED} (RP)$			600	mA
IRED Anode Voltage		$V_{IRED A}$	-0.5		6	V
Transmitter Data Input Voltage		V_{Txd}	-0.5		$V_{CC1} + 0.5$	V
Receiver Data Output Voltage		V_{Rxd}	-0.5		$V_{CC1} + 0.5$	V
Virtual Source Size	Method: (1-1/e) encircled energy	d	2.5	2.8		mm
Maximum Intensity for Class 1 Operation of IEC825-1 or EN60825-1 (worst case IrDA FIR pulse pattern)	EN60825, 1997, unidirectional operation, worst case test mode				320	mW/sr

Electrical Characteristics

$T_{amb} = 25^{\circ}\text{C}$, $V_{CC} = 2.6\text{V}$ to 5.5V unless otherwise noted.

Typical values are for DESIGN AID ONLY, not guaranteed nor subject to production testing.

Parameters	Test Conditions / Pins	Symbol	Min.	Typ.	Max.	Unit
Transceiver						
Supply Voltage		V_{CC}	2.6		5.5	V
Dynamic Supply Current	Receive mode only. In transmit mode, add additional 85 mA (typ) for IRED current					
	SD = Low, $E_e = 0\text{ klx}$	I_{CC}		3	4.5	mA
	SD = Low, $E_e = 1\text{ klx}^*)$	I_{CC}		3	4.5	mA
Standby Supply Current	SD = High, Mode = Floating, $T = 25^{\circ}\text{C}$, $E_e = 0\text{ klx}$ $T = 25^{\circ}\text{C}$, $E_e = 1\text{ klx}^*)$	I_{SD}			1 1.5	μA μA
	SD = High, $T = 85^{\circ}\text{C}$, Mode = Floating, Not Ambient Light Sensitive	I_{SD}			5	μA
Operating Temperature Range		T_A	-25		+85	$^{\circ}\text{C}$
Output Voltage Low	$R_{load} = 2.2\text{ k}\Omega$, $C_{load} = 15\text{ pF}$	V_{OL}		0.5	0.8	V
Output Voltage High	$R_{load} = 2.2\text{ k}\Omega$, $C_{load} = 15\text{ pF}$	V_{OH}	$V_{CC}-0.5$			V
Input Voltage Low (Txd, SD/ Mode, Mode)		V_{IL}	0		0.8	V
Input Voltage High (Txd, SD/ Mode, Mode)	CMOS level **)	V_{IH}	$0.9 \times V_{CC}$			V
	TTL level, $V_{CC} \geq 4.5\text{ V}$	V_{IH}	2.4			V
Input Leakage Current (Txd, SD/ Mode)		I_L	-10		+10	μA
Input Leakage Current, Mode		I_L	-80		+80	μA
Input Capacitance		C_I			5	pF

*) Standard Illuminant A

**) The typical threshold level is between $0.5 \times V_{CC}/2$ ($V_{CC} = 3\text{ V}$) and $0.4 \times V_{CC}$ ($V_{CC} = 5.5\text{ V}$).
It is recommended to use the specified min/ max values to avoid increased operating current.



Optoelectronic Characteristics

$T_{amb} = 25^{\circ}\text{C}$, $V_{CC} = 2.6\text{ V}$ to 5.5 V unless otherwise noted.

Typical values are for DESIGN AID ONLY, not guaranteed nor subject to production testing.

Parameters	Test Conditions	Symbol	Min.	Typ.	Max.	Unit
Receiver						
Minimum Detection Threshold Irradiance, SIR Mode	TFDH6541 9.6 kbit/s to 115.2 kbit/s $\lambda = 850\text{ nm}$ to 900 nm	E_e		20	35	mW/m^2
	TFDH6131 9.6 kbit/s to 115.2 kbit/s $\lambda = 850\text{ nm}$ to 900 nm	E_e		25	40	mW/m^2
Minimum Detection Threshold Irradiance, MIR Mode	TFDH6541 1.152 Mbit/s $\lambda = 850\text{ nm}$ to 900 nm	E_e		50		mW/m^2
	TFDH6131 1.152 Mbit/s $\lambda = 850\text{ nm}$ to 900 nm	E_e		65		mW/m^2
Minimum Detection Threshold Irradiance, FIR Mode	TFDH6541 4.0 Mbit/s $\lambda = 850\text{ nm}$ to 900 nm	E_e		65	100	mW/m^2
	TFDH6131 4.0 Mbit/s $\lambda = 850\text{ nm}$ to 900 nm	E_e		85	100	mW/m^2
Maximum Detection Threshold Irradiance	$\lambda = 850\text{ nm}$ to 900 nm	E_e	5	10		kW/m^2
Logic LOW Receiver Input Irradiance		E_e	4			mW/m^2
Rise Time of Output Signal—,,,klll	10% to 90%, @2.2 k Ω , 15 pF	t_r (Rxd)	10		40	ns
Fall Time of Output Signal	90% to 10%, @2.2 k Ω , 15 pF	t_f (Rxd)	10		40	ns
Rxd Pulse Width of Output Signal, 50% SIR Mode	Input pulse length 20 μs , 9.6 kbit/s	t_{PW}	1.2	10	20	μs
	Input pulse length 1.41 μs , 115.2 kbit/s	t_{PW}	1.2		1/2 bit length	μs
Rxd Pulse Width of Output Signal, 50% MIR Mode	Input pulse length 217 ns, 1.152 Mbit/s	t_{PW}	110		260	ns
Rxd Pulse Width of Output Signal, 50% FIR Mode	Input pulse length 125 ns, 4.0 Mbit/s	t_{PW}	100		160	ns
	Input pulse length 250 ns, 4.0 Mbit/s	t_{PW}	200		290	ns
Stochastic Jitter, Leading Edge, FIR Mode	Input Irradiance = 100 mW/m^2 , 4.0 Mbit/s			± 10		ns
Latency		t_L		120	300	μs

Note: All timing data measured with 4 Mbit/s are measured using the IrDA[®] FIR transmission header. The data given here are valid 5 μs after starting the preamble.

Optoelectronic Characteristics, continued

$T_{amb} = 25^{\circ}\text{C}$, $V_{CC} = 2.6\text{ V}$ to 5.5 V unless otherwise noted.

Typical values are for DESIGN AID ONLY, not guaranteed nor subject to production testing.

Parameters	Test Conditions	Symbol	Min.	Typ.	Max.	Unit
Transmitter						
IRED Operating Current	$R1^{*}) = 7.2\ \Omega$, $V_{CC} = 5.0\text{ V}$	I_D		0.4	0.55	A
Output Radiant Intensity (see Figure 3)	$V_{CC} = 5.0\text{ V}$, $\alpha = 0^{\circ}$, 15° Txd = High, SD = Low, $R1 = 7.2\ \Omega$	I_e	120	170	350	mW/sr
Output Radiant Intensity	$V_{CC} = 5.0\text{ V}$, $\alpha = 0^{\circ}$, 15° Txd = Low, SD = High, (Receiver is inactive as long as SD = High) $R1 = 7.2\ \Omega$	I_e			0.04	mW/sr
Output Radiant Intensity, Angle of Half Intensity		α		± 24		$^{\circ}\text{C}$
Peak – Emission Wavelength		λ_p	880		900	nm
Optical Output Pulse Duration	Input pulse width 217 ns, 1.152 Mbit/s	t_{opt}	207	217	227	ns
	Input pulse width 125 ns, 4 Mbit/s	t_{opt}	117	125	133	ns
	Input pulse width 250 ns, 4 Mbit/s	t_{opt}	242	250	258	ns
	Input pulse width $t < 80\ \mu\text{s}$ Input pulse width $t \geq 80\ \mu\text{s}$	t_{opt}		t	80	μs
Optical Rise Time, Fall Time		t_{ropt} , t_{fopt}	10		40	ns
Optical Overshoot					10	%

*) $R1$: control series resistor for current limitation

Recommended Circuit Diagram

The only required component for designing an IrDA 1.3 solution using Vishay Telefunken transceivers is a current limiting resistor, R1, to the IRED. However, depending on the entire system design and board layout, additional components may be required (see figure KEIN MERKER).

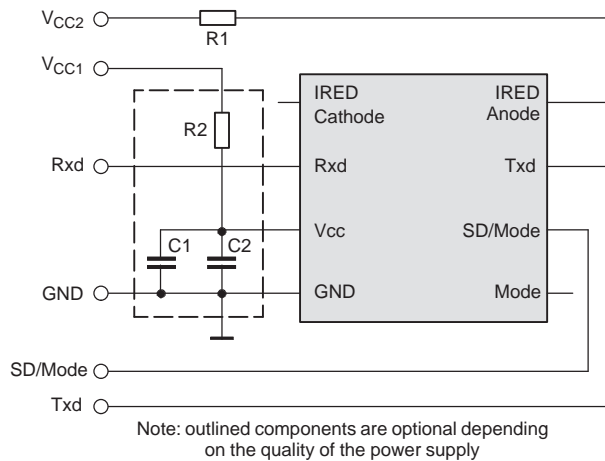

Figure 3. Recommended Application Circuit

Vishay Telefunken transceivers integrate a sensitive receiver and a built-in power driver. The combination of both needs a careful circuit board layout. The use of thin, long, resistive and inductive wiring should be avoided. The inputs (Txd, SD/ Mode) and the output Rxd should be directly (DC) coupled to the I/O circuit.

R1 is used for controlling the current through the IR emitter. For increasing the output power of the IRED, the value of the resistor should be reduced. Similarly, to reduce the output power of the IRED, the value of the resistor should be increased. For typical values of R1 see figure KEIN MERKER. For IrDA compliant operation, a current control resistor of 7.2 Ω is recommended. For compensating losses of the cosmetic window, reducing that value to 5.6 Ω is acceptable. The upper drive current limitation is dependent on the duty cycle and is given by the absolute maximum ratings on the data sheet.

R2, C1 and C2 are optional and dependent on the quality of the supply voltage V_{CC} and injected noise. An unstable power supply with dropping voltage during transmission may reduce sensitivity (and transmission range) of the transceiver.

The placement of these parts is critical. It is strongly recommended to position C2 as near as possible to the transceiver power supply pins. An electrolytic capacitor should be used for C1 while a ceramic capacitor is used for C2.

Table 1. Recommended Application Circuit Components

Component	Recommended Value	Vishay Part Number
C1	4.7 μF, Tantalum	293D 475X9 016B 2T
C2	0.1 μF, Ceramic	VJ 1206 Y 104 J XXMT
R1	5 V supply voltage: 7.2 Ω , 0.25 W (recommend using two 3.6 Ω , 0.125 W resistors in series) 3.3 V supply voltage: 3.6 Ω , 0.25 W (recommend using two 1.8 Ω , 0.125 W resistors in series)	CRCW-1206-3R60-F-RT1 CRCW-1206-1R80-F-RT1
R2	47 Ω , 0.125 W	CRCW-1206-47R0-F-RT1

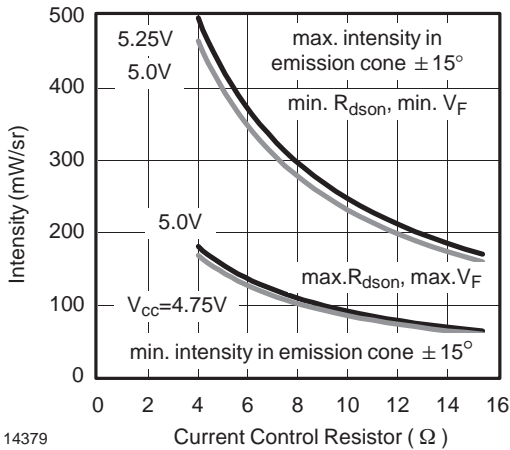

Figure 4. Intensity I_e vs. Current Control Resistor R1, 5 V Applications

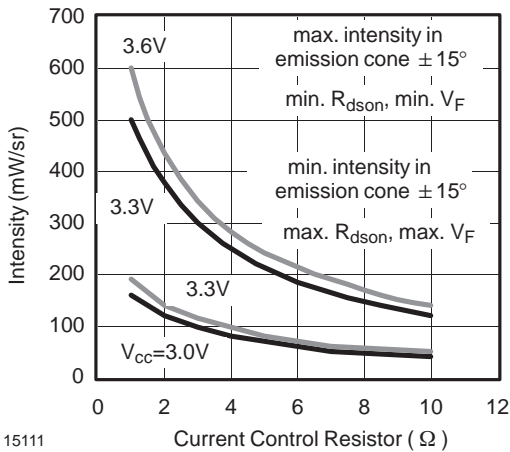

Figure 5. Intensity I_e vs. Current Control Resistor R1, 3 V Applications

In addition, when connecting the described circuit to the power supply, low impedance wiring should be used.

I/O and Software

In the description, already different I/Os are mentioned. Different combinations are tested and the function verified with the special drivers available from the I/O suppliers. In special cases refer to the I/O manual, the Vishay application notes, or contact directly Vishay Sales, Marketing or Application.

Control: Differences to TFDx6000 Series

For applications using I/Os from NSC, Winbond and TI no software upgrade is necessary. In combination with the latest SMSC controllers for Microsoft Windows 98[®] a software upgrade is necessary, drivers are available from SMSC and Vishay Semiconductor GmbH. This software is intended to work with Windows 95[®], too. Alternatively the HP/ Sharp settings can be selected. The Microsoft Operating Systems NT 5.0[®] Beta 2 and Windows 2000[®] provide Miniport device drivers.

Mode Switching

The TFDH6131 and TFDH6541 do not power on with a default mode, therefore the data transfer rate has to be set by a programming sequence using the Txd and SD/ Mode inputs as described below or selected by setting the Mode Pin. The Mode Pin can be used to statically set the mode (Mode Pin: LOW: SIR, HIGH: 0.576 Mbit/s to 4.0 Mbit/s). When using the Mode Pin, the standby current may increase to about 50 to 60 μ A when high or low. If not used or in standby mode, the mode input should float to minimize standby current. The low frequency mode covers speeds up to 115.2 kbit/s. Signals with higher data rates should be detected in the high frequency mode. Lower frequency data can also be received in the high frequency mode but with reduced sensitivity. To switch the transceivers from low frequency mode to the high frequency mode and vice versa, the programming sequences described below are required.

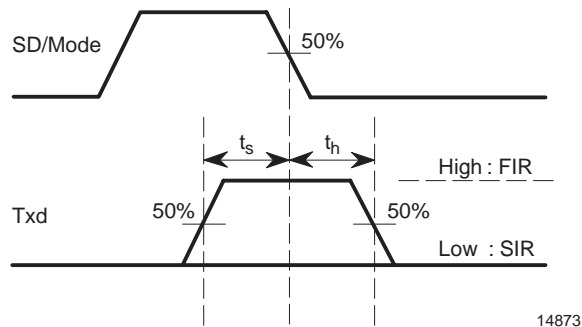

Figure 6. Mode Switching Timing Diagram

Setting to the High Bandwidth Mode (0.576 Mbit/s to 4.0 Mbit/s)

1. Set SD/MODE input to logic "HIGH".
2. Set Txd input to logic "HIGH". Wait $t_s \geq 200$ ns.
3. Set SD/MODE to logic "LOW" (this negative edge latches state of Txd, which determines speed setting).
4. After waiting $t_h \geq 200$ ns Txd can be set to logic "LOW". The hold time of Txd is limited by the maximum allowed pulse length.

Txd is now enabled as normal Txd input for the high bandwidth mode.

Setting to the Lower Bandwidth Mode (2.4 kbit/s to 115.2 kbit/s)

1. Set SD/MODE input to logic "HIGH".
2. Set Txd input to logic "LOW". Wait $t_s \geq 200$ ns.
3. Set SD/MODE to logic "LOW" (this negative edge latches state of Txd, which determines speed setting).
4. Txd must be held for $t_h \geq 200$ ns.

Txd is now enabled as normal Txd input for the lower bandwidth mode.

Current Derating Diagram

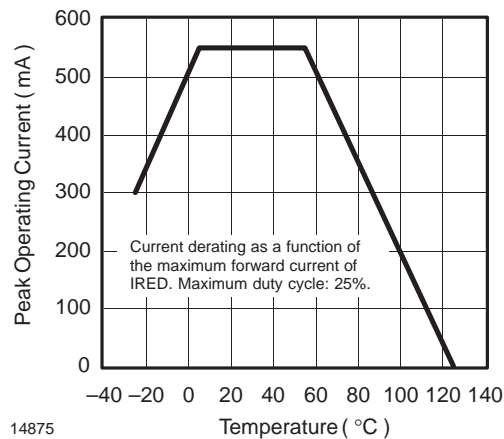
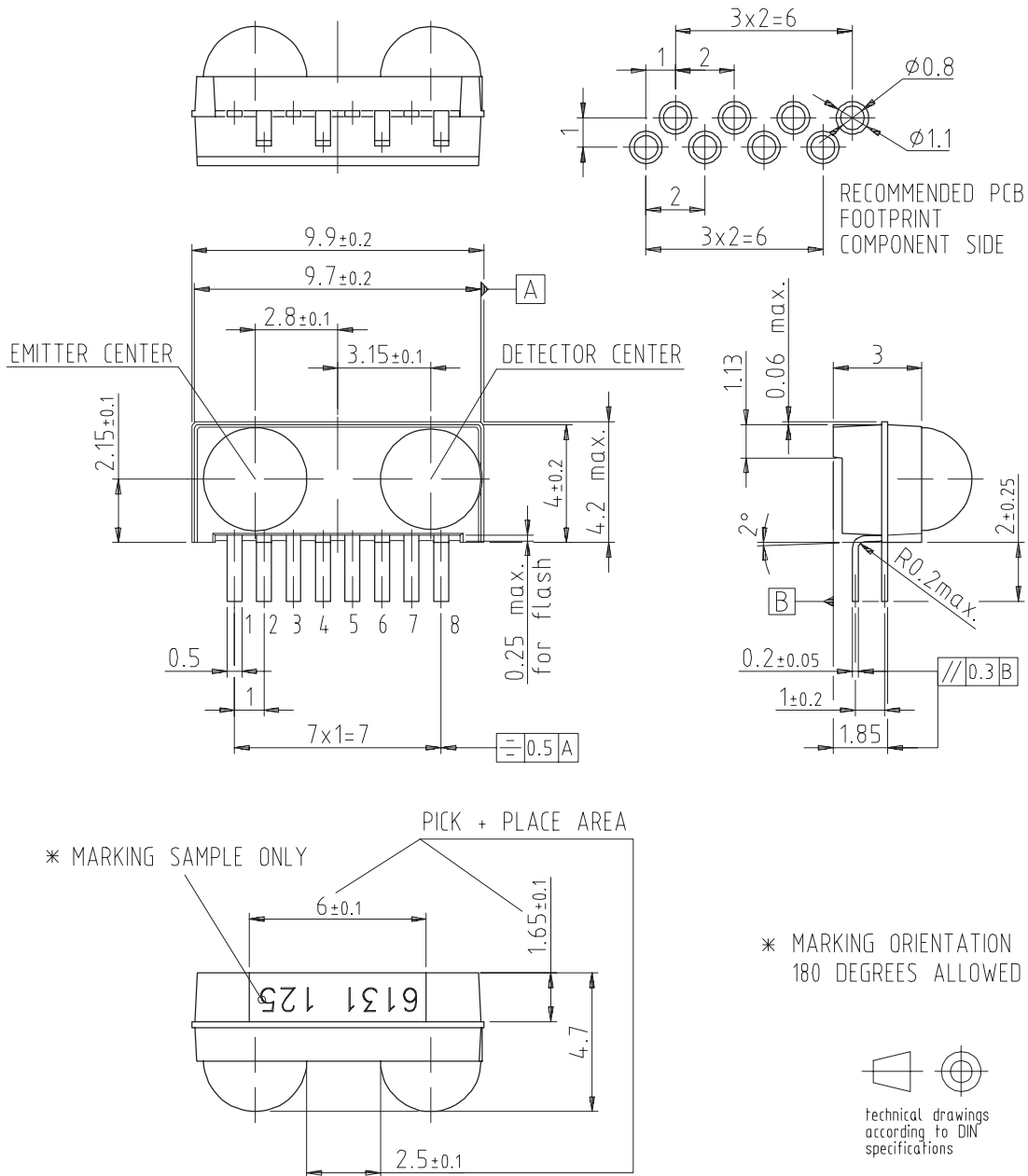
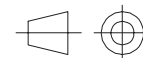

Figure 7. Current Derating Diagram

TFDH6131 – Side View Package (Mechanical Dimensions)



* MARKING ORIENTATION
180 DEGREES ALLOWED



technical drawings
according to DIN
specifications

Drawing-No.: 6.550-5218.01-4
Issue: 1; 14.12.99

Drawing refers to following types: TFDH .131
TFDH .132

15185

TFDH6541 – Side View Package (Mechanical Dimensions)

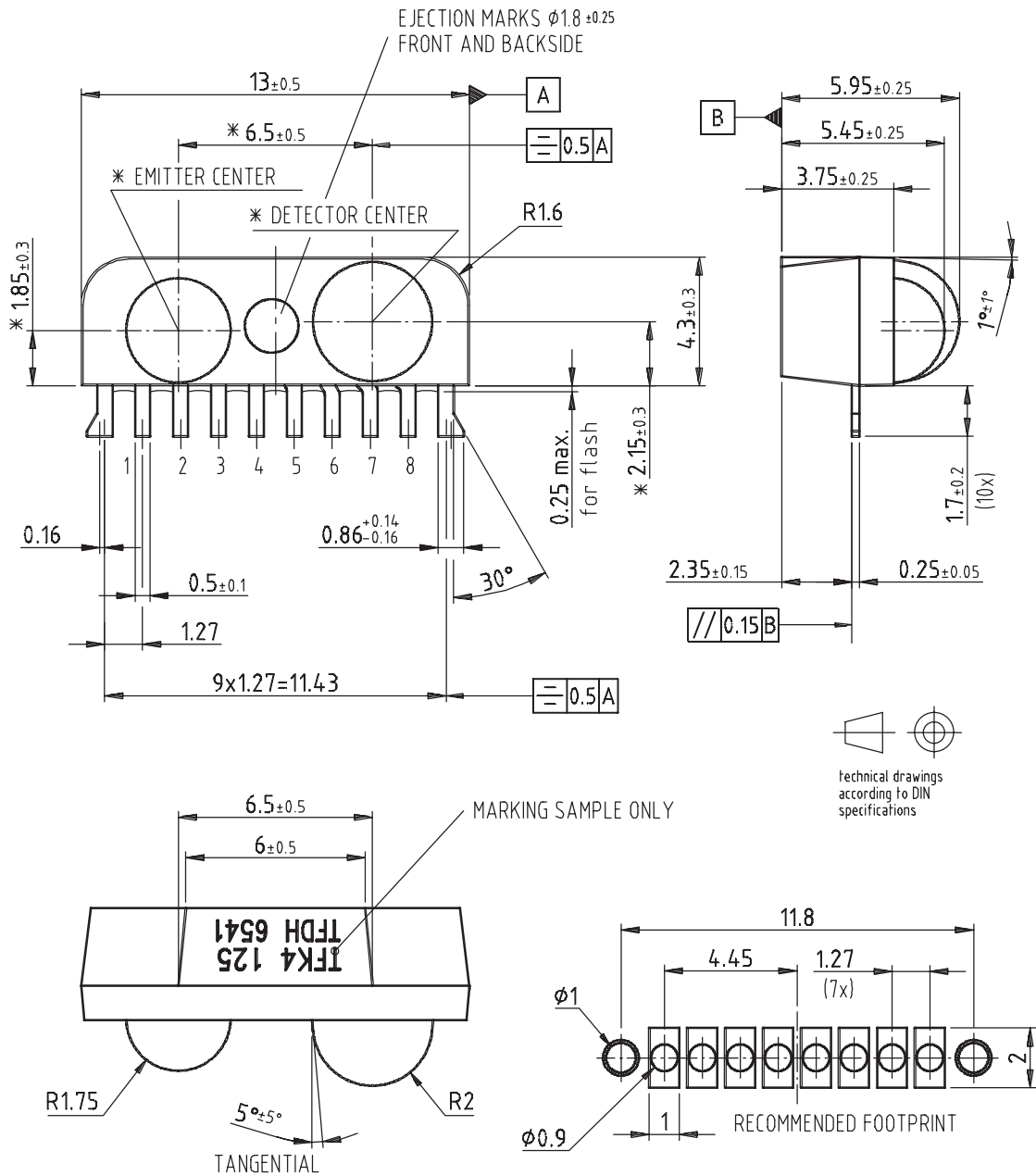

Drawing-No.: 6.550-5217.01-4
Issue: 2; 12.05.00

Drawing refers to following types: TFDH 654.

15184



Revision History:

A1.0, 13/10/2000: Customer release

A1.1, 29/01/2001: Minimum detection threshold irradiance added.
Recommended pad layout changed
Solder profile deleted
Soldering temperature increased



Ozone Depleting Substances Policy Statement

It is the policy of **Vishay Semiconductor GmbH** to

1. Meet all present and future national and international statutory requirements.
2. Regularly and continuously improve the performance of our products, processes, distribution and operating systems with respect to their impact on the health and safety of our employees and the public, as well as their impact on the environment.

It is particular concern to control or eliminate releases of those substances into the atmosphere which are known as ozone depleting substances (ODSs).

The Montreal Protocol (1987) and its London Amendments (1990) intend to severely restrict the use of ODSs and forbid their use within the next ten years. Various national and international initiatives are pressing for an earlier ban on these substances.

Vishay Semiconductor GmbH has been able to use its policy of continuous improvements to eliminate the use of ODSs listed in the following documents.

1. Annex A, B and list of transitional substances of the Montreal Protocol and the London Amendments respectively
2. Class I and II ozone depleting substances in the Clean Air Act Amendments of 1990 by the Environmental Protection Agency (EPA) in the USA
3. Council Decision 88/540/EEC and 91/690/EEC Annex A, B and C (transitional substances) respectively.

Vishay Semiconductor GmbH can certify that our semiconductors are not manufactured with ozone depleting substances and do not contain such substances.

We reserve the right to make changes to improve technical design and may do so without further notice.

Parameters can vary in different applications. All operating parameters must be validated for each customer application by the customer. Should the buyer use Vishay Telefunken products for any unintended or unauthorized application, the buyer shall indemnify Vishay Telefunken against all claims, costs, damages, and expenses, arising out of, directly or indirectly, any claim of personal damage, injury or death associated with such unintended or unauthorized use.

Vishay Semiconductor GmbH, P.O.B. 3535, D-74025 Heilbronn, Germany
Telephone: 49 (0)7131 67 2831, Fax number: 49 (0)7131 67 2423