



CY7C132/CY7C136 CY7C142/CY7C146

2K x 8 Dual-Port Static RAM

Features

- 0.8-micron CMOS for optimum speed/power
- Automatic power-down
- TTL compatible
- Capable of withstanding greater than 2001V electrostatic discharge
- Fully asynchronous operation
- Master CY7C132/CY7C136 easily expands data bus width to 16 or more bits using slave CY7C142/CY7C146
- **BUSY** output flag on CY7C132/CY7C136; **BUSY** input on CY7C142/CY7C146
- **INT** flag for port-to-port communication (52-pin LCC/PLCC/PQFP versions)

Functional Description

The CY7C132/CY7C136/CY7C142 and CY7C146 are high-speed CMOS 2K by 8 dual-port static RAMs. Two ports are provided to permit independent access to any location in memory. The CY7C132/CY7C136 can be utilized as either a stand-alone 8-bit dual-port static RAM or as a MASTER dual-port RAM in conjunction with the CY7C142/CY7C146 SLAVE dual-port device in systems requiring 16-bit or greater word widths. It is the solution to applications requiring shared or buffered data such as cache memory for DSP, bit-slice, or multiprocessor designs.

Each port has independent control pins; chip enable (\overline{CE}), write enable ($\overline{R/W}$), and

output enable (\overline{OE}). **BUSY** flags are provided on each port. In addition, an interrupt flag (**INT**) is provided on each port of the 52-pin LCC and PLCC versions. **BUSY** signals that the port is trying to access the same location currently being accessed by the other port. On the LCC/PLCC versions, **INT** is an interrupt flag indicating that data has been placed in a unique location (7FF for the left port and 7FE for the right port).

An automatic power-down feature is controlled independently on each port by the chip enable (\overline{CE}) pins.

The CY7C132/CY7C142 are available in both 48-pin DIP and 48-pin LCC. The CY7C136/CY7C146 are available in 52-pin LCC, PLCC, and PQFP.

Logic Block Diagram

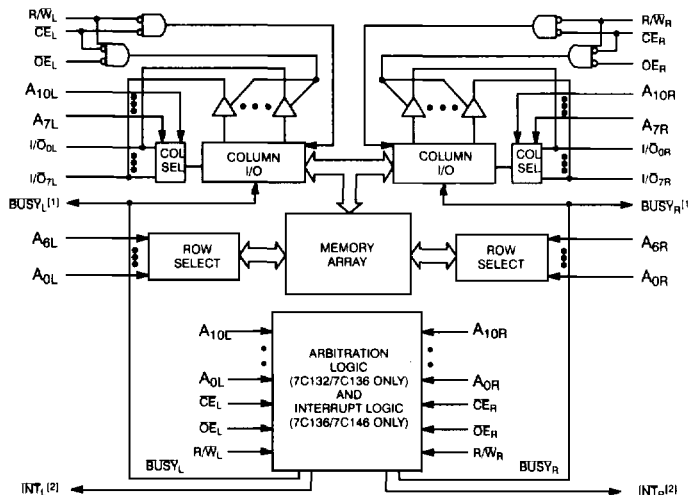

Pin Configuration

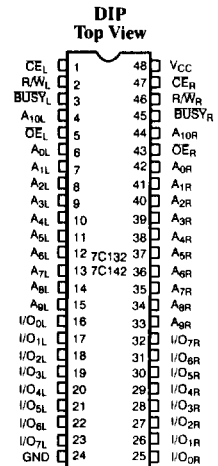

C132-1

C132-2

Notes:

1. CY7C132/CY7C136 (Master): **BUSY** is open drain output and requires pull-up resistor. CY7C142/CY7C146 (Slave): **BUSY** is input.
2. Open drain outputs; pull-up resistor required.



Electrical Characteristics Over the Operating Range^[5]

Parameter	Description	Test Conditions	7C132-25, 30 ^[3] 7C136-25, 30 7C142-25, 30 7C146-25, 30		7C132-35 7C136-35 7C142-35 7C146-35		7C132-45, 55 7C136-45, 55 7C142-45, 55 7C146-45, 55		Unit
			Min.	Max.	Min.	Max.	Min.	Max.	
V _{OH}	Output HIGH Voltage	V _{CC} = Min., I _{OH} = -4.0 mA	2.4		2.4		2.4		V
V _{OL}	Output LOW Voltage	I _{OL} = 4.0 mA		0.4		0.4		0.4	V
		I _{OL} = 16.0 mA ^[6]		0.5		0.5		0.5	
V _{IH}	Input HIGH Voltage		2.2		2.2		2.2		V
V _{IL}	Input LOW Voltage			0.8		0.8		0.8	V
I _{Ix}	Input Load Current	GND ≤ V _I ≤ V _{CC}	-5	+5	-5	+5	-5	+5	μA
I _{OZ}	Output Leakage Current	GND ≤ V _O ≤ V _{CC} , Output Disabled	-5	+5	-5	+5	-5	+5	μA
I _{OS}	Output Short Circuit Current ^[7]	V _{CC} = Max., V _{OUT} = GND		-350		-350		-350	mA
I _{CC}	V _{CC} Operating Supply Current	CE = V _{IL} , Outputs Open, f = f _{MAX} ^[8]	Com'l	170		120		90	mA
			Mil			170		120	
I _{SH1}	Standby Current Both Ports, TTL Inputs	CE _L and CE _R ≥ V _{IH} , f = f _{MAX} ^[8]	Com'l	65		45		35	mA
			Mil			65		45	
I _{SB2}	Standby Current One Port, TTL Inputs	CE _L or CE _R ≥ V _{IH} , Active Port Outputs Open, f = f _{MAX} ^[8]	Com'l	115		90		75	mA
			Mil			115		90	
I _{SB3}	Standby Current Both Ports, CMOS Inputs	Both Ports CE _L and CE _R ≥ V _{CC} - 0.2V, V _{IN} ≥ V _{CC} - 0.2V or V _{IN} ≤ 0.2V, f = 0	Com'l	15		15		15	mA
			Mil			15		15	
I _{SB4}	Standby Current One Port, CMOS Inputs	One Port CE _L or CE _R ≥ V _{CC} - 0.2V, V _{IN} ≥ V _{CC} - 0.2V or V _{IN} ≤ 0.2V, Active Port Outputs Open, f = f _{MAX} ^[8]	Com'l	105		85		70	mA
			Mil			105		85	

Capacitance^[9]

Parameter	Description	Test Conditions	Max.	Unit
C _{IN}	Input Capacitance	T _A = 25°C, f = 1 MHz, V _{CC} = 5.0V	15	pF
C _{OUT}	Output Capacitance		10	pF

Notes:

- See the last page of this specification for Group A subgroup testing information.
- BUSY and INT pins only.
- Duration of the short circuit should not exceed 30 seconds.
- At f = f_{MAX}, address and data inputs are cycling at the maximum frequency of read cycle of 1/t_{rc} and using AC Test Waveforms input levels of GND to 3V.
- Tested initially and after any design or process changes that may affect these parameters.
- Test conditions assume signal transition times of 5 ns or less, timing reference levels of 1.5V, input pulse levels of 0 to 3.0V and output loading of the specified I_{OL}/I_{OHL}, and 30-pF load capacitance.
- AC test conditions use V_{OHL} = 1.6V and V_{OL} = 1.4V.
- At any given temperature and voltage condition for any given device, t_{HZCE} is less than t_{LZCE} and t_{HZOE} is less than t_{LZOE}.
- t_{LZCE}, t_{LZWE}, t_{HZOE}, t_{LZOE}, t_{HZCE}, and t_{HZWE} are tested with C_L = 5pF as in part (b) of AC Test Loads. Transition is measured ±500 mV from steady-state voltage.
- The internal write time of the memory is defined by the overlap of CE LOW and R/W LOW. Both signals must be LOW to initiate a write and either signal can terminate a write by going HIGH. The data input setup and hold timing should be referenced to the rising edge of the signal that terminates the write.

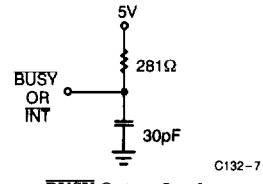
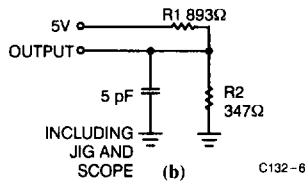
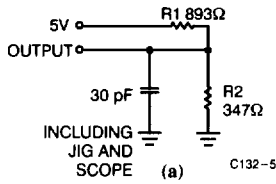
AC Test Loads and Waveforms

**BUSY Output Load
(CY7C132/CY7C136 ONLY)**

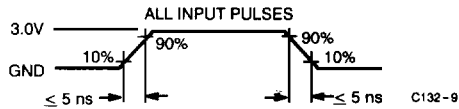
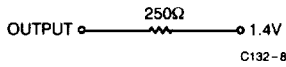
Equivalent to: THEVENIN EQUIVALENT

Switching Characteristics Over the Operating Range^[5, 10]

Parameter	Description	7C132-25 ^[3]		7C132-30		7C132-35		7C132-45		7C132-55		Unit
		Min.	Max.	Min.	Max.	Min.	Max.	Min.	Max.	Min.	Max.	
READ CYCLE												
t _{RC}	Read Cycle Time	25		30		35		45		55		ns
t _{AA}	Address to Data Valid ^[11]		25		30		35		45		55	ns
t _{OHA}	Data Hold from Address Change	0		0		0		0		0		ns
t _{ACE}	CE LOW to Data Valid ^[11]		25		30		35		45		55	ns
t _{DOE}	OE LOW to Data Valid ^[11]		15		20		20		25		25	ns
t _{LZOE}	OE LOW to Low Z ^[12]	3		3		3		3		3		ns
t _{HZOE}	OE HIGH to High Z ^[12, 13]		15		15		20		20		25	ns
t _{LZCE}	CE LOW to Low Z ^[12]	5		5		5		5		5		ns
t _{HZCE}	CE HIGH to High Z ^[12, 13]		15		15		20		20		25	ns
t _{PU}	CE LOW to Power-Up	0		0		0		0		0		ns
t _{PD}	CE HIGH to Power-Down		25		25		35		35		35	ns
WRITE CYCLE^[14]												
t _{WC}	Write Cycle Time	25		30		35		45		55		ns
t _{SCE}	CE LOW to Write End	20		25		30		35		40		ns
t _{AW}	Address Set-Up to Write End	20		25		30		35		40		ns
t _{HA}	Address Hold from Write End	2		2		2		2		2		ns
t _{SA}	Address Set-Up to Write Start	0		0		0		0		0		ns
t _{PWE}	R/W Pulse Width	15		25		25		30		30		ns
t _{SD}	Data Set-Up to Write End	15		15		15		20		20		ns
t _{HD}	Data Hold from Write End	0		0		0		0		0		ns
t _{HZWE}	R/W LOW to High Z		15		15		20		20		25	ns
t _{LZWE}	R/W HIGH to Low Z	0		0		0		0		0		ns

Switching Characteristics Over the Operating Range^[5, 10] (continued)

Parameter	Description	7C132-25 ^[3]		7C132-30		7C132-35		7C132-45		7C132-55		Unit
		7C136-25		7C136-30		7C136-35		7C136-45		7C136-55		
		Min.	Max.	Min.	Max.	Min.	Max.	Min.	Max.	Min.	Max.	
BUSY/INTERRUPT TIMING												
t _{BLA}	BUSY LOW from Address Match		20		20		20		25		30	ns
t _{BHA}	BUSY HIGH from Address Mismatch ^[15]		20		20		20		25		30	ns
t _{BLC}	BUSY LOW from \overline{CE} LOW		20		20		20		25		30	ns
t _{BHC}	BUSY HIGH from \overline{CE} HIGH ^[15]		20		20		20		25		30	ns
t _{PS}	Port Set Up for Priority	5		5		5		5		5		ns
t _{WB} ^[16]	R/W LOW after BUSY LOW	0		0		0		0		0		ns
t _{WH}	R/W HIGH after BUSY HIGH	20		30		30		35		35		ns
t _{BDD}	BUSY HIGH to Valid Data		25		30		35		45		45	ns
t _{DDD}	Write Data Valid to Read Data Valid		Note 17		Note 17		Note 17		Note 17		Note 17	ns
t _{WDD}	Write Pulse to Data Delay		Note 17		Note 17		Note 17		Note 17		Note 17	ns
INTERRUPT TIMING^[18]												
t _{WINS}	R/W to INTERRUPT Set Time		25		25		25		35		45	ns
t _{EINS}	\overline{CE} to INTERRUPT Set Time		25		25		25		35		45	ns
t _{INS}	Address to INTERRUPT Set Time		25		25		25		35		45	ns
t _{OINR}	\overline{OE} to INTERRUPT Reset Time ^[15]		25		25		25		35		45	ns
t _{EINR}	\overline{CE} to INTERRUPT Reset Time ^[15]		25		25		25		35		45	ns
t _{INR}	Address to INTERRUPT Reset Time ^[15]		25		25		25		35		45	ns

Notes:

15. These parameters are measured from the input signal changing, until the output pin goes to a high-impedance state.
16. CY7C142/CY7C146 only.
17. A write operation on Port A, where Port A has priority, leaves the data on Port B's outputs undisturbed until one access time after one of the following:
 - A. BUSY on Port B goes HIGH.
 - B. Port B's address toggled.
 - C. \overline{CE} for Port B is toggled.
 - D. R/W for Port B is toggled during valid read.
18. 52-pin LCC/PLCC versions only.
19. R/W is HIGH for read cycle.
20. Device is continuously selected, $\overline{CE} = V_{IL}$ and $\overline{OE} = V_{IL}$.
21. Address valid prior to or coincident with \overline{CE} transition LOW.
22. If \overline{OE} is LOW during a R/W controlled write cycle, the write pulse width must be the larger of t_{PWE} or t_{HZWE} + t_{SD} to allow the data I/O pins to enter high impedance and for data to be placed on the bus for the required t_{SD}.
23. If the \overline{CE} LOW transition occurs simultaneously with or after the R/W LOW transition, the outputs remain in a high-impedance state.

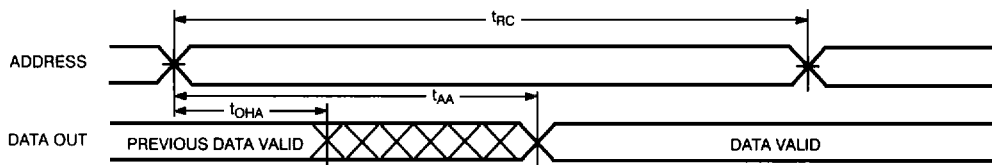
Switching Waveforms
Read Cycle No. 1 (Either Port – Address Access)^[19, 20]

C132-10

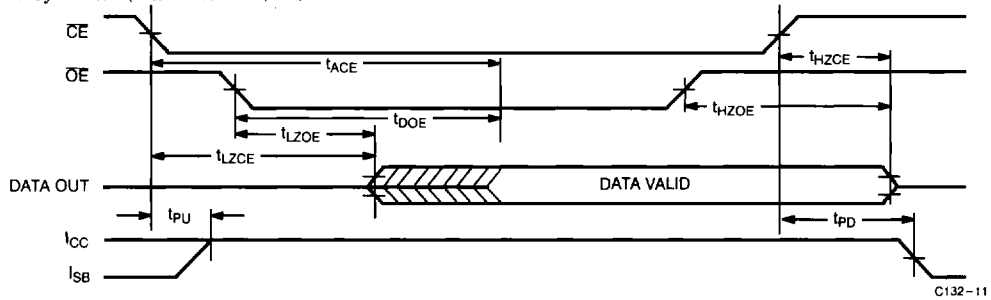
Switching Waveforms (continued)
Read Cycle No. 2 (Either Port – $\overline{CE}/\overline{OE}$) [19, 21]

C132-11

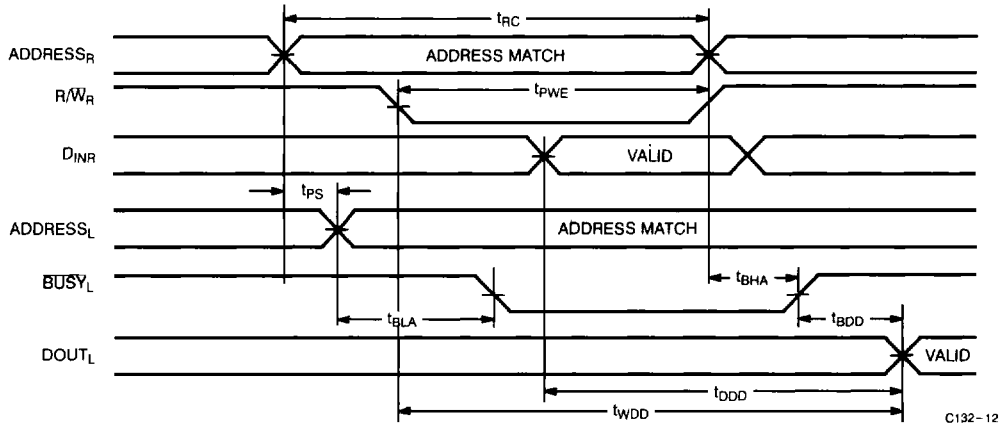
Read Cycle No. 3 (Read with \overline{BUSY} Master: CY7C132 and CY7C136)

C132-12

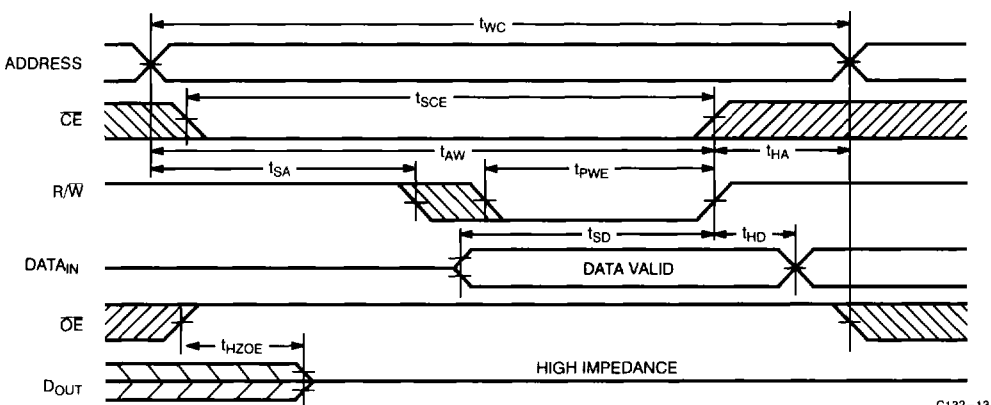
Write Cycle No. 1 (\overline{OE} Three-States Data I/Os – Either Port) [14, 22]

C132-13

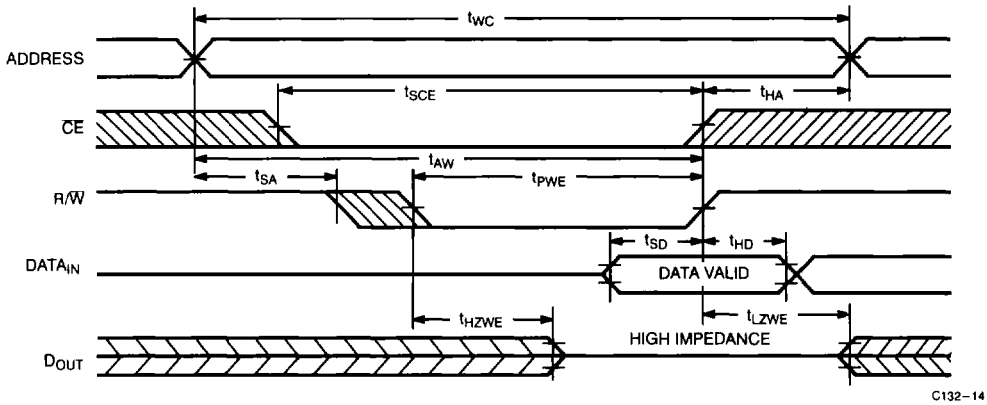
Switching Waveforms (continued)
Write Cycle No. 2 (R/W Three-States Data I/Os - Either Port)^[14, 23]

C132-14

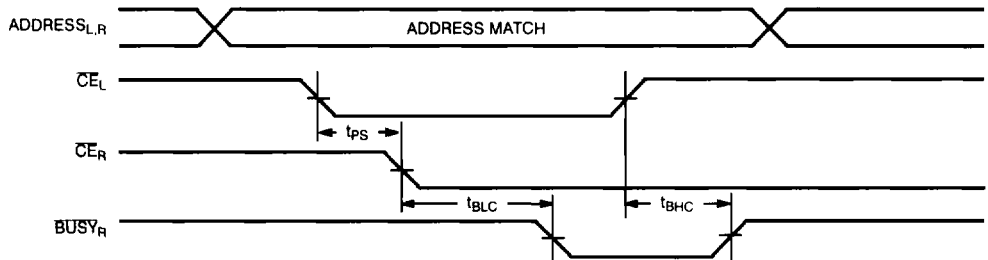
Busy Timing Diagram No. 1 (CE Arbitration)
 \overline{CE}_L Valid First:

C132-15

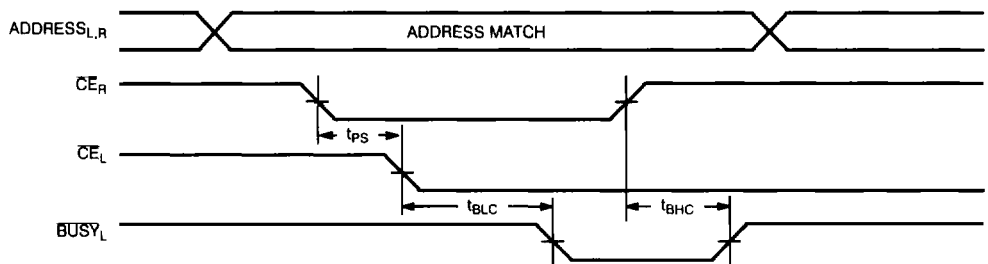
 \overline{CE}_R Valid First:

C132-16

Switching Waveforms (continued)
Busy Timing Diagram No. 2 (Address Arbitration)

Left Address Valid First:

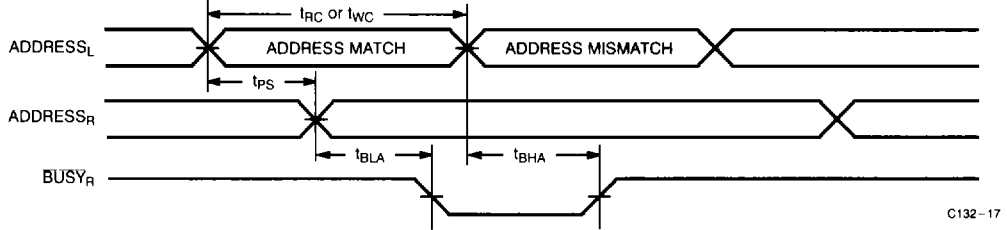

Right Address Valid First:

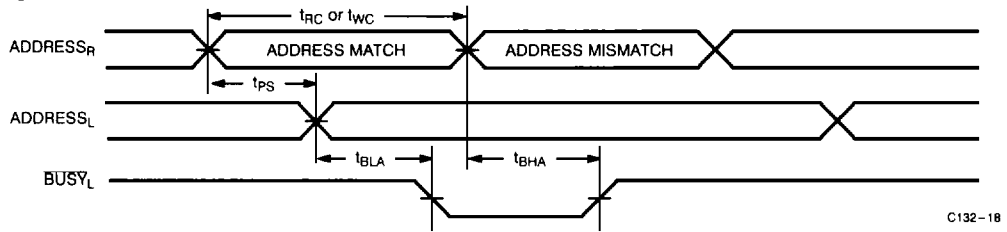
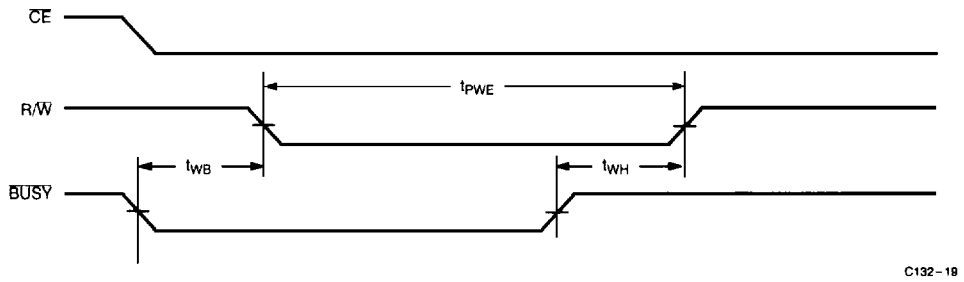
Busy Timing Diagram No. 3 (Write with $\overline{\text{BUSY}}$, Slave: CY7C142/CY7C146)

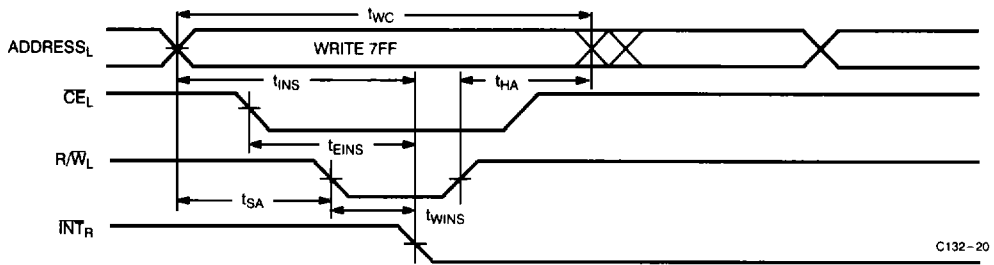
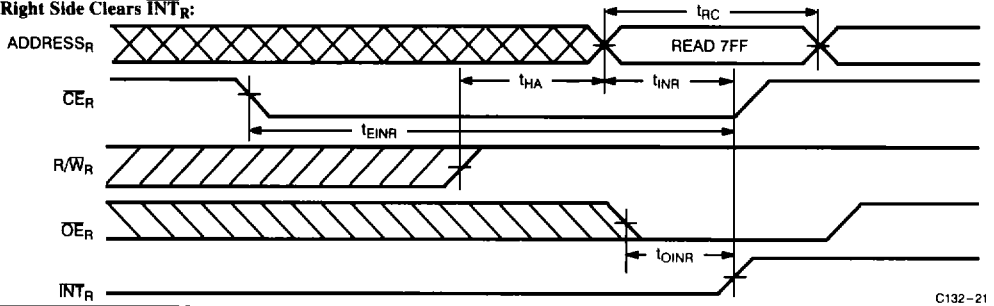
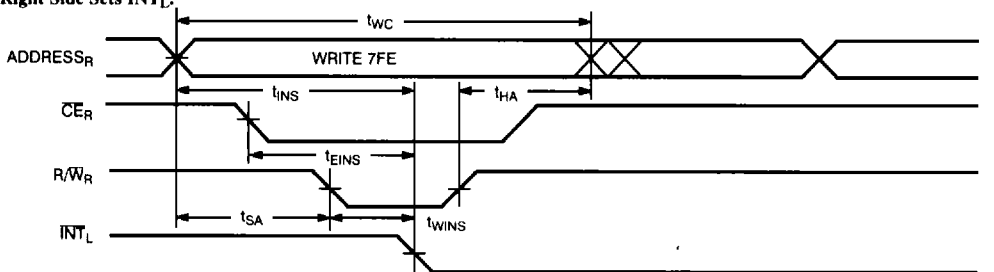
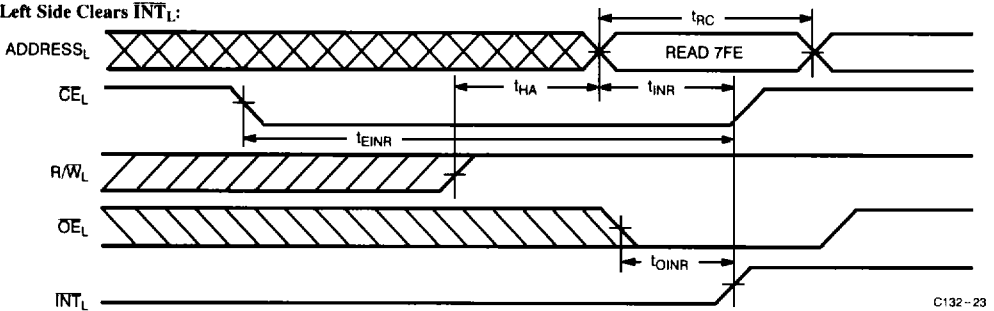
Interrupt Timing Diagrams⁽¹⁸⁾
Left Side Sets INT_R :

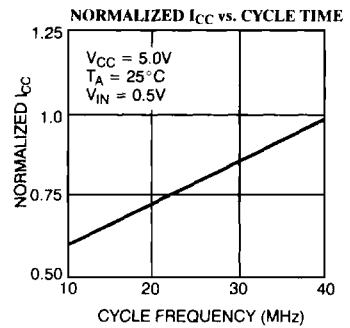
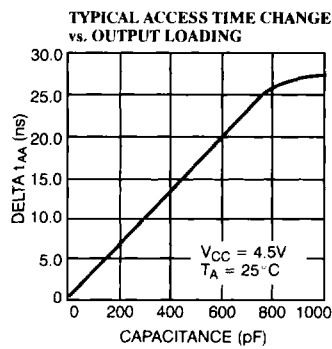
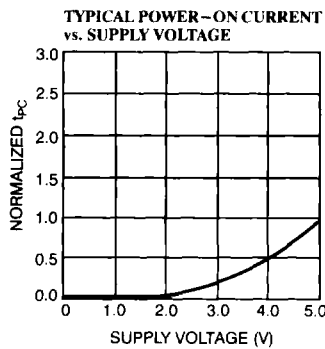
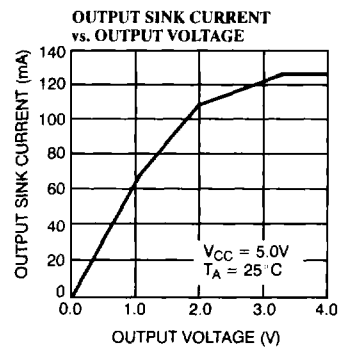
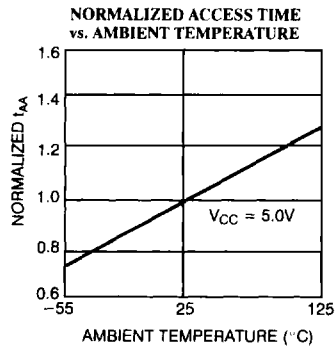
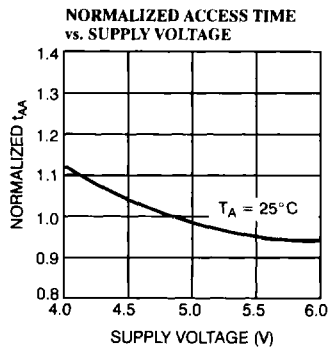
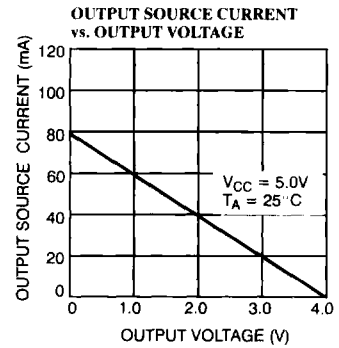
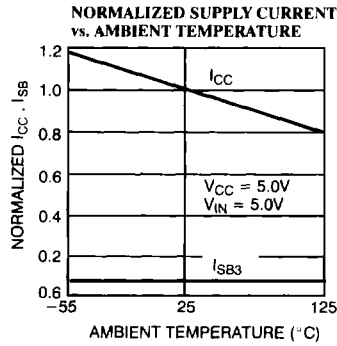
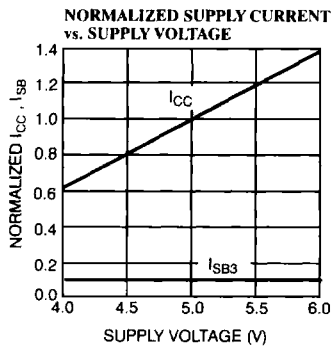
Right Side Clears INT_R :

Right Side Sets INT_L :

Left Side Clears INT_L :

Typical DC and AC Characteristics



Ordering Information

Speed (ns)	Ordering Code	Package Name	Package Type	Operating Range
30	CY7C132-30PC	P25	48-Lead (600-Mil) Molded DIP	Commercial
	CY7C132-30PI	P25	48-Lead (600-Mil) Molded DIP	Industrial
35	CY7C132-35PC	P25	48-Lead (600-Mil) Molded DIP	Commercial
	CY7C132-35PI	P25	48-Lead (600-Mil) Molded DIP	Industrial
	CY7C132-35DMB	D26	48-Lead (600-Mil) Sidebrazed DIP	Military
45	CY7C132-45PC	P25	48-Lead (600-Mil) Molded DIP	Commercial
	CY7C132-45PI	P25	48-Lead (600-Mil) Molded DIP	Industrial
	CY7C132-45DMB	D26	48-Lead (600-Mil) Sidebrazed DIP	Military
55	CY7C132-55PC	P25	48-Lead (600-Mil) Molded DIP	Commercial
	CY7C132-55PI	P25	48-Lead (600-Mil) Molded DIP	Industrial
	CY7C132-55DMB	D26	48-Lead (600-Mil) Sidebrazed DIP	Military

Speed (ns)	Ordering Code	Package Name	Package Type	Operating Range
25	CY7C136-25JC	J69	52-Lead Plastic Leaded Chip Carrier	Commercial
	CY7C136-25NC	N52	52-Pin Plastic Quad Flatpack	
30	CY7C136-30JC	J69	52-Lead Plastic Leaded Chip Carrier	Commercial
	CY7C136-30NC	N52	52-Pin Plastic Quad Flatpack	Industrial
	CY7C136-30JI	J69	52-Lead Plastic Leaded Chip Carrier	
35	CY7C136-35JC	J69	52-Lead Plastic Leaded Chip Carrier	Commercial
	CY7C136-35NC	N52	52-Pin Plastic Quad Flatpack	Industrial
	CY7C136-35JI	J69	52-Lead Plastic Leaded Chip Carrier	
	CY7C136-35LMB	L69	52-Square Leadless Chip Carrier	Military
45	CY7C136-45JC	J69	52-Lead Plastic Leaded Chip Carrier	Commercial
	CY7C136-45NC	N52	52-Pin Plastic Quad Flatpack	Industrial
	CY7C136-45JI	J69	52-Lead Plastic Leaded Chip Carrier	
	CY7C136-45LMB	L69	52-Square Leadless Chip Carrier	Military
55	CY7C136-55JC	J69	52-Lead Plastic Leaded Chip Carrier	Commercial
	CY7C136-55NC	N52	52-Pin Plastic Quad Flatpack	Industrial
	CY7C136-55JI	J69	52-Lead Plastic Leaded Chip Carrier	
	CY7C136-55LMB	L69	52-Square Leadless Chip Carrier	Military



Ordering Information

Speed (ns)	Ordering Code	Package Name	Package Type	Operating Range
30	CY7C142-30PC	P25	48-Lead (600-Mil) Molded DIP	Commercial
	CY7C142-30PI	P25	48-Lead (600-Mil) Molded DIP	Industrial
35	CY7C142-35PC	P25	48-Lead (600-Mil) Molded DIP	Commercial
	CY7C142-35PI	P25	48-Lead (600-Mil) Molded DIP	Industrial
	CY7C142-35DMB	D26	48-Lead (600-Mil) Sidebrazed DIP	Military
45	CY7C142-45PC	P25	48-Lead (600-Mil) Molded DIP	Commercial
	CY7C142-45PI	P25	48-Lead (600-Mil) Molded DIP	Industrial
	CY7C142-45DMB	D26	48-Lead (600-Mil) Sidebrazed DIP	Military
55	CY7C142-55PC	P25	48-Lead (600-Mil) Molded DIP	Commercial
	CY7C142-55PI	P25	48-Lead (600-Mil) Molded DIP	Industrial
	CY7C142-55DMB	D26	48-Lead (600-Mil) Sidebrazed DIP	Military

Speed (ns)	Ordering Code	Package Name	Package Type	Operating Range
25	CY7C146-25JC	J69	52-Lead Plastic Leaded Chip Carrier	Commercial
	CY7C146-25NC	N52	52-Pin Plastic Quad Flatpack	
30	CY7C146-30JC	J69	52-Lead Plastic Leaded Chip Carrier	Commercial
	CY7C146-30NC	N52	52-Pin Plastic Quad Flatpack	
	CY7C146-30JI	J69	52-Lead Plastic Leaded Chip Carrier	Industrial
35	CY7C146-35JC	J69	52-Lead Plastic Leaded Chip Carrier	Commercial
	CY7C146-35NC	N52	52-Pin Plastic Quad Flatpack	
	CY7C146-35JI	J69	52-Lead Plastic Leaded Chip Carrier	Industrial
	CY7C146-35LMB	L69	52-Square Leadless Chip Carrier	Military
45	CY7C146-45JC	J69	52-Lead Plastic Leaded Chip Carrier	Commercial
	CY7C146-45NC	N52	52-Pin Plastic Quad Flatpack	
	CY7C146-45JI	J69	52-Lead Plastic Leaded Chip Carrier	Industrial
	CY7C146-45LMB	L69	52-Square Leadless Chip Carrier	Military
55	CY7C146-55JC	J69	52-Lead Plastic Leaded Chip Carrier	Commercial
	CY7C146-55NC	N52	52-Pin Plastic Quad Flatpack	
	CY7C146-55JI	J69	52-Lead Plastic Leaded Chip Carrier	Industrial
	CY7C146-55LMB	L69	52-Square Leadless Chip Carrier	Military

6



MILITARY SPECIFICATIONS

Group A Subgroup Testing

DC Characteristics

Parameter	Subgroups
V _{OH}	1, 2, 3
V _{OL}	1, 2, 3
V _{IH}	1, 2, 3
V _{IL Max.}	1, 2, 3
I _{Ix}	1, 2, 3
I _{OZ}	1, 2, 3
I _{CC}	1, 2, 3
I _{SB1}	1, 2, 3
I _{SB2}	1, 2, 3
I _{SB3}	1, 2, 3
I _{SB4}	1, 2, 3

Switching Characteristics

Parameter	Subgroups
READ CYCLE	
t _{RC}	7, 8, 9, 10, 11
t _{AA}	7, 8, 9, 10, 11
t _{ACE}	7, 8, 9, 10, 11
t _{DOE}	7, 8, 9, 10, 11
WRITE CYCLE	
t _{WC}	7, 8, 9, 10, 11
t _{SCE}	7, 8, 9, 10, 11
t _{AW}	7, 8, 9, 10, 11
t _{HA}	7, 8, 9, 10, 11
t _{SA}	7, 8, 9, 10, 11
t _{PWE}	7, 8, 9, 10, 11
t _{SD}	7, 8, 9, 10, 11
t _{HD}	7, 8, 9, 10, 11

Parameter	Subgroups
BUSY/INTERRUPT TIMING	
t _{BLA}	7, 8, 9, 10, 11
t _{BHA}	7, 8, 9, 10, 11
t _{BLC}	7, 8, 9, 10, 11
t _{BHC}	7, 8, 9, 10, 11
t _{PS}	7, 8, 9, 10, 11
t _{WINS}	7, 8, 9, 10, 11
t _{EINS}	7, 8, 9, 10, 11
t _{INS}	7, 8, 9, 10, 11
t _{OINR}	7, 8, 9, 10, 11
t _{EINR}	7, 8, 9, 10, 11
t _{INR}	7, 8, 9, 10, 11
BUSY TIMING	
t _{WB} ^[24]	7, 8, 9, 10, 11
t _{WH}	7, 8, 9, 10, 11
t _{BDD}	7, 8, 9, 10, 11

Note:

24. CY7C142/CY7C146 only.

Document #: 38-00061-J