



WRC4 Series Discrete I/O expands WRC's complete line of discrete I/O modules. These modules provide an indication LED and replaceable fuse. They also meet an industry de facto standard pin-out.

The WRC4 package offers the following advantages:

- Status LED is more easily visible
- Fuse can be tested and replaced without removing the modules
- Fuse is a popular CE-rated fuse
- Popular Euro-style fuse has multiple sources
- Matches the industry de facto standard footprint
- Low height convenient for mounting
- Compact footprint continues to save space
- Compatible with WRC's line of SmartMux and data acquisition cards
- UL and CE marks standard
- 5, 15 and 24 volt logic available
- Proven reliable circuitry

Nine mounting boards are available with spare fuse, power-on LED and fuse test circuit.

WRC4 input modules

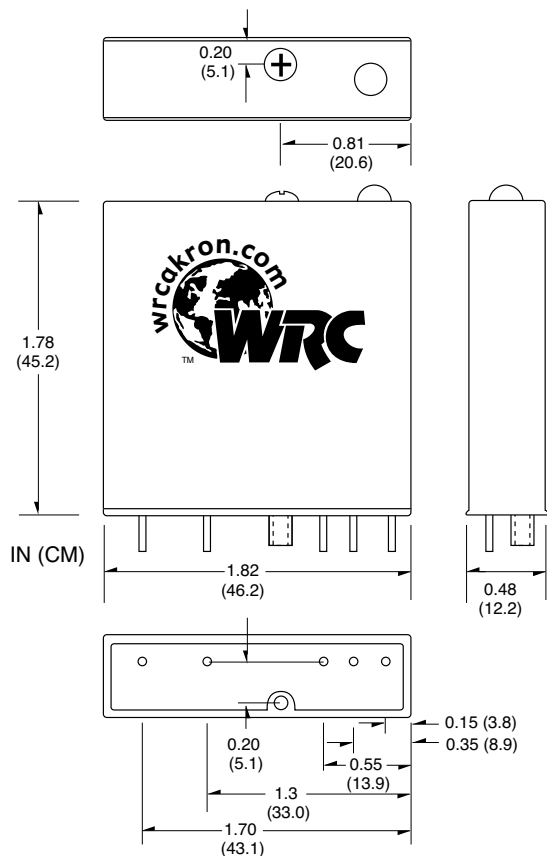

WRC4 output modules

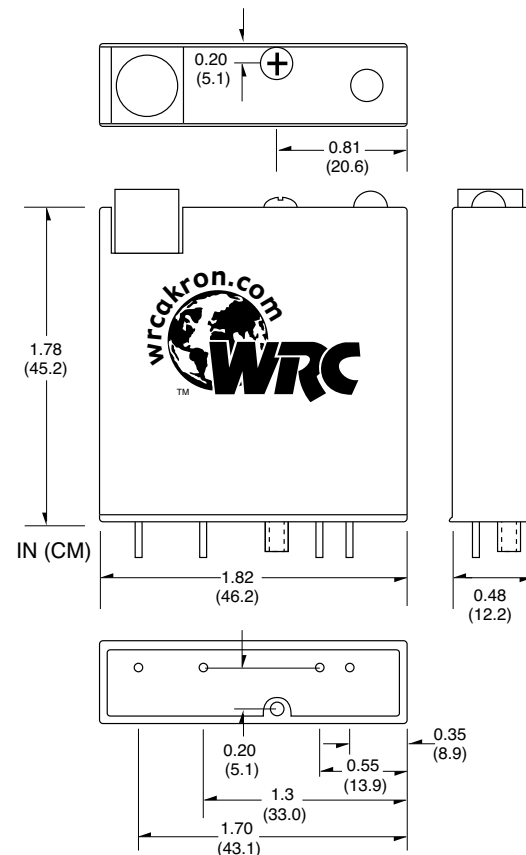

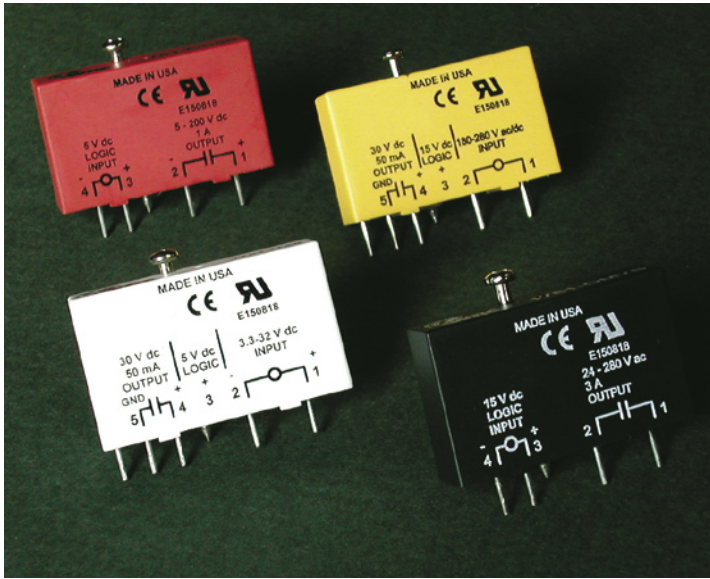

1781-Series of Slim input and output modules and solid-state relays provide compatibility with a variety of manufacturers' miniature modules. Slim modules have a hold-down screw, and can be used in mounting boards where vibration and shock are not of concern.

All modules are UL recognized and CE compliant.

The 1781-Slim package offers the following advantages:

- Matches the industry de facto standard pin-out footprint
- Smaller footprint allow 30% space savings over Classic
- Lower height convenient for mounting
- Includes hold-down screw
- Compatible with WRC's line of SmartMux and data acquisition cards
- UL and CE marks standard
- 5, 15 and 24 volt logic available
- Proven reliable circuitry

18 mounting boards are available (most with spare fuse, power-on LED and fuse test circuit.)

Slim input modules

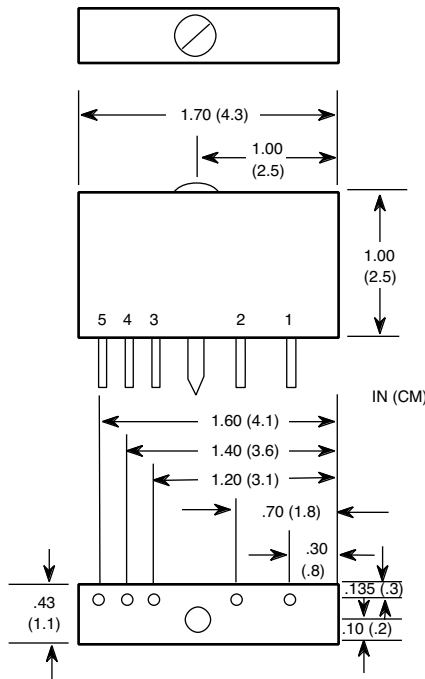

Slim output modules

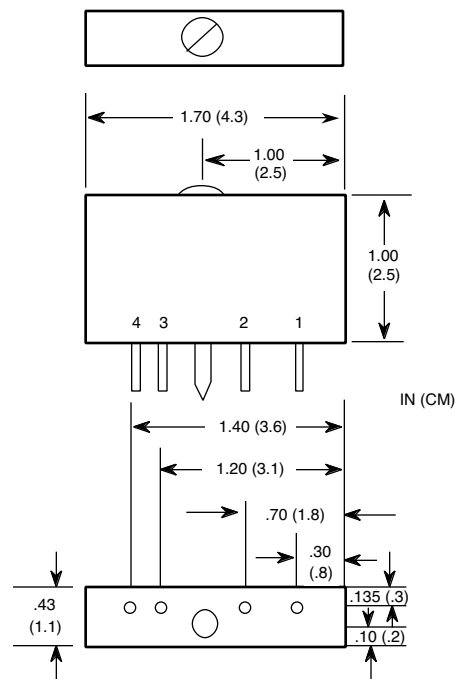



The Classic design has the same footprints as the de facto industry standard 0.6" style I/O modules. They have a hold-down screw, and can be used in mounting boards where shock and vibration are present.

All modules are UL recognized and CE compliant.

The Classic package offers the following advantages:

- Includes hold-down screw
- Compatible with WRC's line of SmartMux and data acquisition cards
- UL and CE marks standard
- 5, 15 and 24 volt logic available
- Proven reliable circuitry

Several mounting boards are available with spare fuse, power-on LED and fuse test circuit.

Standard input modules

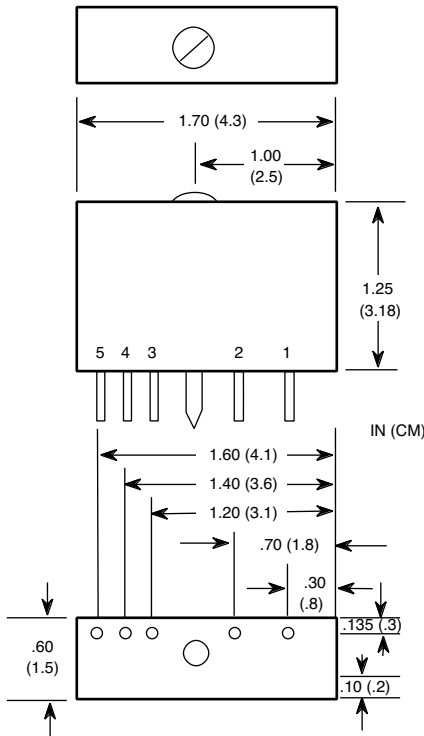

Standard output modules

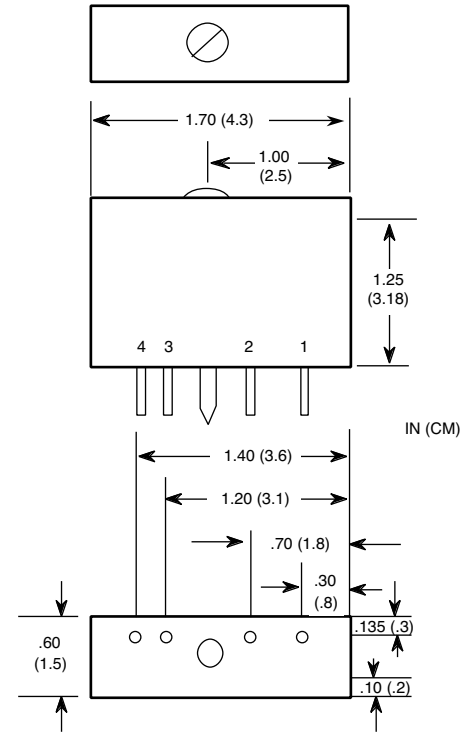

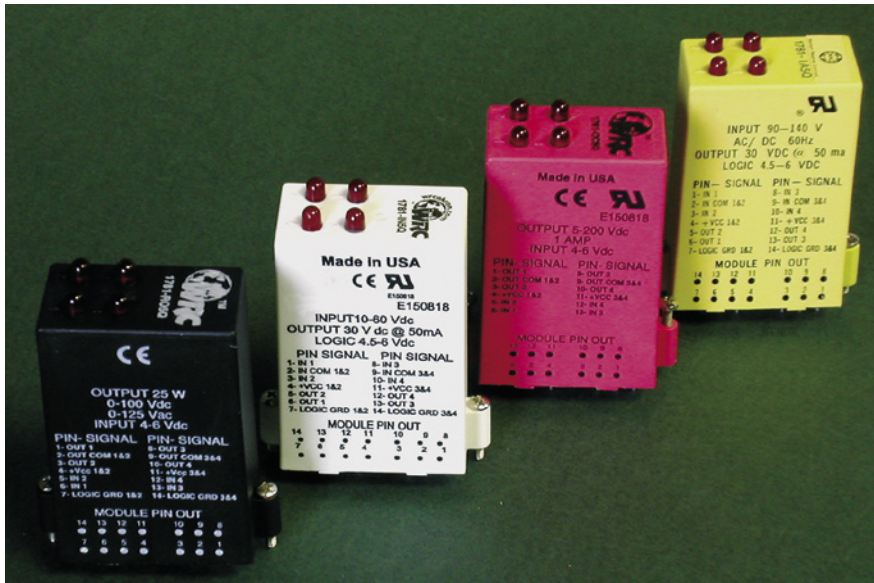

1781-Series Quad Modules are available in all of the field voltages as the 1781-Series of Slim Modules or the WRC4-Series of modules. They provide four I/O circuits in one package with an integral LED for each circuit.

The 1781-Series of Quad I/O Modules are compatible with the de facto industry standard footprints, however, attention should be given to applications where dc inputs and outputs are involved to confirm the proper polarity. Different vendors have implemented these functions in different ways. WRC offers several different versions allowing the user to meet the polarity needs for your application. Refer to the application notes section of the catalog which discuss sourcing and sinking applications.

UL recognized and CE compliant are standard.

Quad input modules

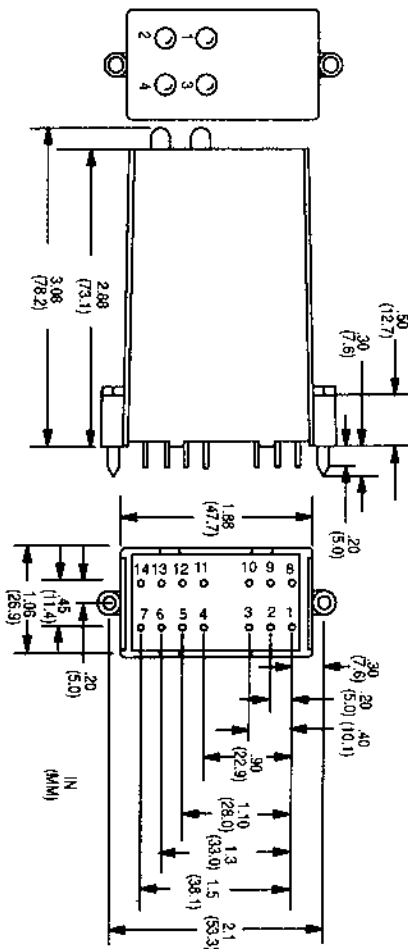

Quad output modules

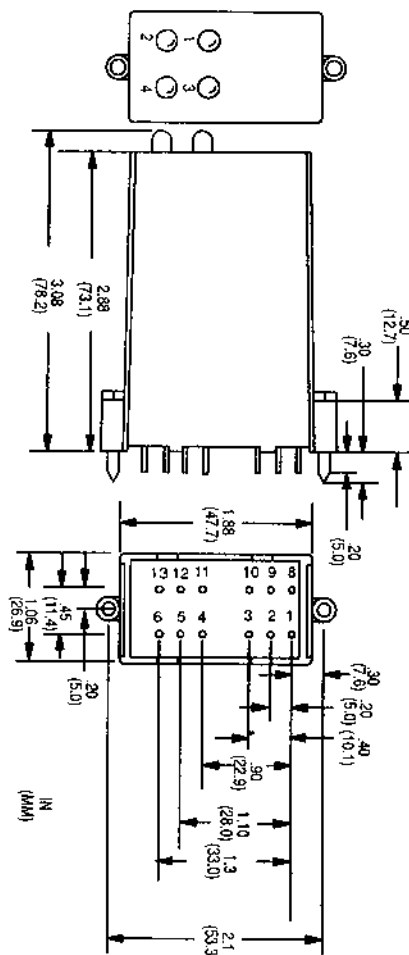



PRODUCT	STYLE	PRODUCT	STYLE	PRODUCT	STYLE	PRODUCT	STYLE	TYPE	FIELD VOLTAGE	LOGIC VOLTAGE	NOTES
1781-IA5S	Slim	WRC4-IA5S	Integral	1781-IA5M	Mini	IAC5	Classic 0.6"	Input	90-140 V ac/dc	5 V	1, 3
1781-IAYS	Slim	WRC4-IAYS	Integral	1781-IAYM	Mini	IAC15	Classic 0.6"	Input	90-140 V ac/dc	15 V	1, 3
1781-IAXS	Slim	WRC4-IAXS	Integral	1781-IAXM	Mini	IAC24	Classic 0.6"	Input	90-140 V ac/dc	24 V	1, 3
1781-IB5S	Slim	WRC4-IB5S	Integral	1781-IB5M	Mini	IDC5D	Classic 0.6"	Input	3.3-32 V dc	5 V	1, 3
1781-IBYS	Slim	WRC4-IBYS	Integral	1781-IBYM	Mini	IDC15D	Classic 0.6"	Input	3.3-32 V dc	15 V	1, 3
1781-IBXS	Slim	WRC4-IBXS	Integral	1781-IBXM	Mini	IDC24D	Classic 0.6"	Input	3.3-32 V dc	24 V	1, 3
1781-IT5S	Slim	WRC4-IT5S	Integral	1781-IT5M	Mini	IDC5K	Classic 0.6"	Input	3.3-32 V dc	5 V	3, 4
1781-ITYS	Slim	WRC4-ITYS	Integral	1781-ITYM	Mini			Input	3.3-32 V dc	15 V	3, 4
1781-ITXS	Slim	WRC4-ITXS	Integral	1781-ITXM	Mini			Input	3.3-32 V dc	24 V	3, 4
1781-IM5S	Slim	WRC4-IM5S	Integral	1781-IM5M	Mini	IAC5A	Classic 0.6"	Input	180-280 V ac/dc	5 V	1, 3
1781-IMYS	Slim	WRC4-IMYS	Integral	1781-IMYM	Mini	IAC15A	Classic 0.6"	Input	180-280 V ac/dc	15 V	1, 3
1781-IMXS	Slim	WRC4-IMXS	Integral	1781-IMXM	Mini	IAC24A	Classic 0.6"	Input	180-280 V ac/dc	24 V	1, 3
1781-IN5S	Slim	WRC4-IN5S	Integral	1781-IN5M	Mini	IDC5	Classic 0.6"	Input	10-60 V ac/dc	5 V	1, 3
1781-INYS	Slim	WRC4-INYS	Integral	1781-INYM	Mini	IDC15	Classic 0.6"	Input	10-60 V ac/dc	15 V	1, 3
1781-INXS	Slim	WRC4-INXS	Integral	1781-INXM	Mini	IDC24	Classic 0.6"	Input	10-60 V ac/dc	24 V	1, 3
1781-OA5S	Slim	WRC4-OA5S	Integral	1781-OA5M	Mini	OAC5	Classic 0.6"	Zero Cross Output	12-140 V ac	5 V	1, 3
1781-OAYS	Slim	WRC4-OAYS	Integral	1781-OAYM	Mini	OAC15	Classic 0.6"	Zero Cross Output	12-140 V ac	15 V	1, 3
1781-OAXS	Slim	WRC4-OAXS	Integral	1781-OAXM	Mini	OAC24	Classic 0.6"	Zero Cross Output	12-140 V ac	24 V	1, 3
1781-OB5S	Slim	WRC4-OB5S	Integral	1781-OB5M	Mini	ODC5	Classic 0.6"	Output	3-60 V dc	5 V	1, 3
1781-OBYS	Slim	WRC4-OBYS	Integral	1781-OBYM	Mini	ODC15	Classic 0.6"	Output	3-60 V dc	15 V	1, 3
1781-OBXS	Slim	WRC4-OBXS	Integral	1781-OBXM	Mini	ODC24	Classic 0.6"	Output	3-60 V dc	24 V	1, 3
1781-OC5S	Slim	WRC4-OC5S	Integral	1781-OC5M	Mini	ODC5A	Classic 0.6"	Output	5-200 V dc	5 V	1, 3
1781-OCYS	Slim	WRC4-OCYS	Integral	1781-OCYM	Mini	ODC15A	Classic 0.6"	Output	5-200 V dc	15 V	1, 3
1781-OCXS	Slim	WRC4-OCXS	Integral	1781-OCXM	Mini	ODC24A	Classic 0.6"	Output	5-200 V dc	24 V	1, 3
1781-OF5S	Slim	WRC4-OF5S	Integral					MOSFET Output	0-50 V dc	5 V	1, 3
1781-OFYS	Slim	WRC4-OFYS	Integral					MOSFET Output	0-50 V dc	15 V	1, 3
1781-OFXS	Slim	WRC4-OFXS	Integral					MOSFET Output	0-50 V dc	24 V	1, 3
1781-OG5S	Slim	WRC4-OG5S	Integral					MOSFET Output	0-100 V dc	5 V	1, 3
1781-OGYS	Slim	WRC4-OGYS	Integral					MOSFET Output	0-100 V dc	15 V	1, 3
1781-OGXS	Slim	WRC4-OGXS	Integral					MOSFET Output	0-100 V dc	24 V	1, 3
1781-OL5S	Slim	WRC4-OL5S	Integral					Zero Cross Output	24-280 V ac	5 V	1, 3
1781-OM5S	Slim	WRC4-OM5S	Integral	1781-OM5M	Mini	OAC5A	Classic 0.6"	Zero Cross Output	24-280 V ac	5 V	1, 3
1781-OMYS	Slim	WRC4-OMYS	Integral	1781-OMYM	Mini	OAC15A	Classic 0.6"	Zero Cross Output	24-280 V ac	15 V	1, 3
1781-OMXS	Slim	WRC4-OMXS	Integral	1781-OMXM	Mini	OAC24A	Classic 0.6"	Zero Cross Output	24-280 V ac	24 V	1, 3
1781-OM5SC	Slim	WRC4-OM5SC	Integral			OAC5A5	Classic 0.6"	N.C. Zero Cross Output	24-280 V ac	5 V	1, 3
1781-OMYSC	Slim	WRC4-OMYSC	Integral					N.C. Zero Cross Output	24-280 V ac	15 V	1, 3
1781-OMXSC	Slim	WRC4-OMXSC	Integral					N.C. Zero Cross Output	24-280 V ac	24 V	1, 3
1781-OM5SR	Slim	WRC4-OM5SR	Integral			OAC5A11	Classic 0.6"	Instant On Output	24-280 V ac	5 V	1, 3
1781-OMYSR	Slim	WRC4-OMYSR	Integral			OAC15A11	Classic 0.6"	Instant On Output	24-280 V ac	15 V	1, 3
1781-OMXSR	Slim	WRC4-OMXSR	Integral			OAC24A11	Classic 0.6"	Instant On Output	24-280 V ac	24 V	1, 3
1781-OP5S	Slim	WRC4-OP5S	Integral					Zero Cross Output	24-480 V ac	5 V	1, 3
1781-OPYS	Slim	WRC4-OPYS	Integral					Zero Cross Output	24-480 V ac	15 V	1, 3
1781-OPXS	Slim	WRC4-OPXS	Integral					Zero Cross Output	24-480 V ac	24 V	1, 3
1781-RO5S	Slim	WRC4-RO5S	Integral			ODC5R	Classic 0.6"	N.O. Relay	Relay	5 V	2, 3, 4
1781-ROYS	Slim	WRC4-ROYS	Integral			ODC15R	Classic 0.6"	N.O. Relay	Relay	15 V	2, 3, 4
1781-ROXS	Slim	WRC4-ROXS	Integral			ODC24R	Classic 0.6"	N.O. Relay	Relay	24 V	2, 3, 4
1781-RC5S	Slim	WRC4-RC5S	Integral			ODC5R5		N.C. Relay	Relay	5 V	2, 3, 4
1781-RCYS	Slim	WRC4-RCYS	Integral			ODC15R5		N.C. Relay	Relay	15 V	2, 3, 4
1781-RCXS	Slim	WRC4-RCXS	Integral			ODC24R5		N.C. Relay	Relay	24 V	2, 3, 4
1781-SW5S	Slim	WRC4-SW5S	Integral					Switch Input/output	n/a	5 V	3
1781-SWYS	Slim	WRC4-SWYS	Integral					Switch Input/output	n/a	15 V	3
1781-SWXS	Slim	WRC4-SWXS	Integral					Switch Input/output	n/a	24 V	3
1781-WO5S	Slim	WRC4-WO5S	Integral					N.O. Watchdog Timer	N.O. Relay	5 V	2
1781-WC5S	Slim	WRC4-WC5S	Integral					N.C. Watchdog Timer	N.C. Relay	5 V	2
1781-IA5Q	Quad							Input	90-140 V ac/dc	5 V	1, 3
1781-IB5Q	Quad							Input	3.3-32 V dc	5 V	1, 3
1781-IM5Q	Quad							Input	180-280 V ac/dc	5 V	1, 3
1781-IN5Q	Quad							Input	10-60 V ac/dc	5 V	1, 3
1781-IT5Q	Quad							Input	3.3-32 V dc	5 V	3, 4
1781-OA5Q	Quad							Output	12-140 V ac	5 V	1, 3
1781-OB5Q	Quad							Output	3-60 V dc	5 V	1, 3
1781-OC5Q	Quad							Output	5-200 V dc	5 V	1, 3
1781-OM5Q	Quad							Output	24-280 V ac	5 V	1, 3
1781-RO5Q	Quad							N.O. Relay	Relay	5 V	2, 3, 4
1781-RC5Q	Quad							N.C. Relay	Relay	5 V	2, 3, 4

Connect this side to page 7

Notes: 1. UL recognized – File E150818 2. 500V isolation not optically isolated 3. CE compliant 4. CVL



Connect this side to page 6

Potter Brumfield	OPTO-22	Grayhill	Crouzet/Gordos	Continental	Analog Devices	1781 or WRC4 Module	Power Side Watts		Signal Side Module		Watts per Module	
	(G4) note 5	(G5) note 5	(C4) note 5				Nom.	Max.	Nom.	Max.	Nom.	Max.
IAC-5	IAC5	70-IAC5	IAC5(N)	I/O3-IAC-05-000	IA140A	IA5S	1	1.4	0.1	0.1	1.2	1.6
	IAC15	70-IAC15		I/O3-IAC-15-000		IAYS	1	1.4	0.15	0.25	1.3	1.8
IAC-24	IAC24	70-IAC24	IAC24	I/O3-IAC-24-000		IAXS	1	1.4	0.2	0.4	1.4	2
IDC-5	IDC5D(B)	70-IDC5	IDC5(N)	I/O3-IDCD-05-000		IB5S	0.6	1.1	0.1	0.1	0.8	1.3
		70-IDC15				IBYS	0.6	1.05	0.15	0.25	0.9	1.45
IDC-24		70-IDC24	IDC24			IBXS	0.6	1	0.2	0.4	1	1.6
IDC-5F	IDC5K	70-IDC5B	IDC5F			IT5S	0.6	1.1	0.1	0.1	0.8	1.3
						ITXS	0.6	1	0.2	0.4	1	1.6
IDC-24F			IDC24F			ITYS	0.6	1	0.2	0.4	1	1.6
IAC-5A	IAC5A	70-IAC5A	IAC5A	I/O3-IAC-05-A00	IA280A	IM5S	1.5	2.3	0.1	0.1	1.7	2.5
	IAC15A	70-IAC15A		I/O3-IAC-15-A00		IMYS	1.5	2.3	0.15	0.25	1.8	2.7
IAC-24A	IAC24A	70-IAC24A	IAC5A	I/O3-IAC-24-A00		IMXS	1.5	2.3	0.2	0.4	1.9	2.9
IAC-5E	IDC5(G)	70-IDC5NP	IDC5(N)	I/O3-IDC-05-A00	ID016/1	IN5S	0.3	1.8	0.1	0.1	0.5	2
	IDC15	70-IDC15NP		I/O3-IDC-15-A00		INYS	0.3	1.8	0.15	0.25	0.6	2.2
IAC-24E	IDC24	70-IDC24NP	IDC24(N)	I/O3-IDC-24-A00		INXS	0.3	1.8	0.2	0.4	0.7	2.4
OAC-5	OAC5	70-OAC5	OAC5	I/O3-OAC-05-A00	OA140A	OA5S	2.4	4.8	0.1	0.2	2.6	5.1
	OAC15	70-OAC15		I/O3-OAC-15-A00		OAYS	2.4	4.8	0.15	0.3	2.7	5.25
OAC-24	OAC24	70-OAC24	OAC24	I/O3-OAC-24-A00		OAXS	2.4	4.8	0.2	0.4	2.8	5.4
ODC-5	ODC5	70-ODC5	ODC5(F)	I/O3-ODC-05-A00	OD060	OB5S	2.3	4.5	0.1	0.2	2.5	4.8
	ODC15	70-ODC15		I/O3-ODC-15-A00		OBYS	2.3	4.5	0.2	0.35	2.65	5
ODC-24	ODC24	70-ODC24	ODC24(F)	I/O3-ODC-24-A00		OBXS	2.3	4.5	0.3	0.5	2.8	5.2
ODC-5A	ODC5A	70-OAC5A	ODC5A			OCSS	0.8	1.6	0.1	0.2	1	1.9
	ODC15A					OCYS	0.8	1.6	0.2	0.35	1.15	2.1
ODC-24A	ODC24A					OCXS	0.8	1.6	0.3	0.5	1.3	2.3
			ODC24A			OF5S	0.8	1.3	0.1	0.1	0.9	1.4
		70-ODC5B	ODC5MA(MC/ML)			OFYS	0.8	1.3	0.15	0.25	1.0	1.6
		70-ODC15B				OFXS	0.8	1.3	0.2	0.4	1.0	1.7
		70-ODC24B	ODC24MA(MC/ML)			OG5S	1.3	2.5	0.1	0.1	1.4	2.6
						OGYS	1.3	2.5	0.15	0.25	1.5	2.8
						OGXS	1.3	2.5	0.2	0.4	1.5	2.9
OAC-5A	OAC5A	70-OAC5A	OAC5A	I/O3-OAC-05-A00	OA280A	OL5S	2.4	4.8	0.1	0.2	2.6	5.1
OAC-5A	OAC5A	70-OAC5A	OAC5A	I/O3-OAC-05-A00	OA280A	OM5S	2.4	4.8	0.1	0.2	2.6	5.1
	OAC15A	70-OAC15A		I/O3-OAC-15-A00		OMYS	2.4	4.8	0.15	0.3	2.7	5.25
OAC-24A	OAC24A	70-OAC24A	OAC24A	I/O3-OAC-24-A00		OMXS	2.4	4.8	0.2	0.4	2.8	5.4
	OAC5A5					OM5SC	2.4	4.8	0.1	0.2	2.6	5.1
						OMYS	2.4	4.8	0.15	0.3	2.7	5.25
						OMXSC	2.4	4.8	0.2	0.4	2.8	5.4
OAC5R	OAC5A11	70-OAC5A-1	OAC5(A)R			OM5SR	2.4	4.8	0.1	0.2	2.6	5.1
		70-OAC24A-1				OMYSR	2.4	4.8	0.15	0.3	2.7	5.25
			OAC5AH			OMXSR	2.4	4.8	0.2	0.4	2.8	5.4
OAC5AH						OP5S	2.4	4.8	0.1	0.2	2.5	5.0
						OPYS	2.4	4.8	0.15	0.3	2.6	5.1
						OPXS	2.4	4.8	0.2	0.4	2.6	5.2
	ODC5R	70-ODC5R	ORR5			RO5S	0.02	0.1	0.2	0.3	0.2	0.4
						ROYS	0.02	0.1	0.35	0.45	0.35	0.55
			ORR24			ROXS	0.02	0.1	0.5	0.6	0.5	0.7
	ODC5R5					RC5S	0.02	0.1	0.2	0.3	0.2	0.4
						RCYS	0.02	0.1	0.35	0.45	0.35	0.55
						RCXS	0.02	0.1	0.5	0.6	0.5	0.7
						SW5S	0.02	0.1	0.2	0.3	0.2	0.4
						SWYS	0.02	0.1	0.35	0.45	0.35	0.55
						SWXS	0.02	0.1	0.5	0.6	0.5	0.7
						WO5S	0.02	0.1	0.2	0.3	0.2	0.4
						WC5S	0.02	0.1	0.2	0.3	0.2	0.4
	IAC5Q		IAC5Q		IA120Q	IA5Q	-	-	-	-	4.2	6
			IDC5Q			IB5Q	-	-	-	-	2.4	4.5
	IAC5AQ		IAC5AQ		IA240Q	IM5Q	-	-	-	-	6	9.4
	IDC5Q		IAC5EQ		ID32Q	IN5Q	-	-	-	-	1.2	7.6
	IDC5Q/IDC5BQ		IDC5Q/IDC5BQ		ID16FQ	IT5Q	-	-	-	-	2.4	4.5
	OAC5Q		OAC5Q			OA5Q	-	-	-	-	9.8	12.4
	ODC5Q		ODC5Q		OD60Q	OB5Q	-	-	-	-	9.2	11.7
	ODC5AQ		ODC5AQ			OC5Q	-	-	-	-	3.4	6.8
	OAC5Q		OAC5AQ		OA240	OM5Q	-	-	-	-	9.8	12.4
			ORR5Q			RO5Q	-	-	-	-	2	2.8
						RC5Q	-	-	-	-	2	2.8

5. C4, G4 and G5 prefixes cross to WRC4

- To specify the WRC4 package, use the prefix “WRC4” (eg. WRC4-IA5S.)
- To specify the slim package, use the “S” suffix with the 1781 prefix (eg. 1781-IA5S.)
- To specify the mini package, use the “M” suffix with the 1781 prefix (eg. 1781-IA5M.)
- To specify the standard package, use the “Classic” part number (eg. IAC5.)
- All cases are yellow, with the exception of white IN cases.

INPUT: WRC4 & 1781	IA5S	IAYS	IAXS	IM5S	IMYS	IMXS	IN5S IA5SE	INYS	INXS	Units
INPUT: CLASSIC	IAC5	IAC15	IAC24	IAC5A	IAC15A	IAC24A	IDC5	IDC15	IDC24	
Nominal Input Voltage	120	120	120	240	240	240	24	24	24	Vrms/Vdc
Minimum Input Voltage	90	90	90	180	180	180	10	10	10	Vrms/Vdc
Maximum Input Voltage	140	140	140	280	280	280	60	60	60	Vrms/Vdc
Maximum Input Current	10	10	10	8	8	8	30	30	30	mA rms
Drop Out Current	2.5	2.5	2.5	1.5	1.5	1.5	1.0	1.0	1.0	mA rms
Allowable Off-state Current	3.0	3.0	3.0	2.0	2.0	2.0	1.0	1.0	1.0	mA rms
Allowable Off-state Voltage	50	50	50	120	120	120	2.0	2.0	2.0	Vrms/Vdc
OUTPUT										
Nominal Logic Voltage	5	15	24	5	15	24	5	15	25	V dc
Minimum Logic Voltage - WRC4	3	10	18	3	10	18	3	10	18	V dc
Minimum Logic Voltage - 1781*	1.5	8.5	16.5	1.5	8.5	16.5	1.5	8.5	16.5	V dc
Maximum Logic Voltage - WRC4	7	20	32	7	20	32	7	20	32	V dc
Maximum Logic Voltage - 1781*	6	19	30.5	6	19	30.5	6	19	30.5	V dc
Typical Logic Supply Current	10	10	10	10	10	10	10	10	10	mA dc
Max. Logic Supply Current**	18.5	16	14	18.5	16	14	18.5	16	14	mA dc
Max. Logic Sup. Leak. Current**	10	10	10	10	10	10	10	10	10	uA dc
Maximum Output Voltage	30	30	30	30	30	30	30	30	30	V dc
Maximum Output Current	50	50	50	50	50	50	50	50	50	mA dc
Max. Output Leakage Current**	10	10	10	10	10	10	10	10	10	uA dc
Max. Output Voltage Drop	200	200	200	200	200	200	200	200	200	mV dc
Maximum Turn-on Time (Vac)	20	20	20	20	20	20	20	20	20	msec
Maximum Turn-off Time (Vac)	30	30	30	30	30	30	30	30	30	msec
Maximum Turn-on Time (Vdc)	1	1	1	1	1	1	1	1	1	msec
Maximum Turn-off Time (Vdc)	1	1	1	1	1	1	1	1	1	msec

* @ nominal voltage with LED on mounting board

** @ maximum logic voltage

General specifications

Operating temperature range	-30 to +80°C
Storage temperature range	-40 to +100°C
Isolation	4,000 V rms
Capacitance input to output	8 pF
Line frequency range	0 to 63 Hz

Application notes

- Do not install or remove modules in live (electrically hot) circuits. High voltage may be present.
- Input connections are non-polarized.

1781 and Classic

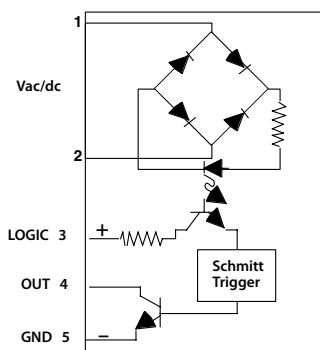

WRC4

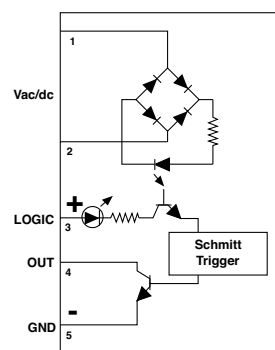

Single-point AC Output

- To specify the WRC4 package, use the prefix “WRC4” (eg. WRC4-OA5S.)
- To specify the slim package, use the “S” suffix with the 1781 prefix (eg. 1781-OA5S.)
- To specify the mini package, use the “M” suffix with the 1781 prefix (eg. 1781-OA5M.)
- To specify the standard package, use the “Classic” part number (eg. OAC5A)

INPUT: WRC4 and 1781	OA5S	OAYS	OAXS	OL5S	OM5S	OM5MS	OMYS	OMXS	OM5SC	OMYSC	OMXSC	OM5SR	OMYSR	OMXSR	OP5S	OPYS	OPXS	Units
INPUT: CLASSIC	OAC5	OAC15	OAC24		OAC5A		OAC15A	OAC24A	OAC5A5			OAC5A11	OAC15A11	OAC24A11				
Nominal input voltage	5	15	24	5	5	5	15	24	5	15	24	5	15	24	5	15	24	V dc
Min input volt. @ pin 3 -WRC4	4	10	18	4	4	4	10	18	4	10	18	4	10	18	4	10	18	V dc
Min input volt. @ pin 3 -1781	2.5	8.5	16.5	2.5	2.5	3	8.5	16.5	2.5	8.5	16.5	2.5	8.5	16.5	2.5	8.5	16.5	V dc
Max input volt. @ pin 3 -WRC4	7.5	20	30.5	7.5	7.5	7.5	20	30.5	7.5	20	30.5	7.5	20	30.5	7.5	20	30.5	V dc
Max input volt. @ pin 3 -1781	7.5	20	30.5	7.5	7.5	32	20	30.5	7.5	20	30.5	7.5	20	30.5	7.5	20	30.5	V dc
Must turn off voltage -WRC4	2.0	2.0	2.0	2.0	2.0	2.0	2.0	2.0	2.0	2.0	2.0	2.0	2.0	2.0	2.0	2.0	2.0	V dc
Must turn off voltage -1781	2.0	2.0	2.0	2.0	2.0	2.0	2.0	2.0	2.0	2.0	2.0	2.0	2.0	2.0	2.0	2.0	2.0	V dc
Typical input current	10	10	10	10	10	10	10	10	10	10	10	10	10	10	10	10	10	mA dc
Maximum input current	27	20	13.5	27	27	27	20	13.5	27	20	13.5	27	20	13.5	27	20	13.5	mA dc
Nominal input resistance	240	900	2.2K	240	240	240	900	2.2K	240	900	2.2K	240	900	2.2K	240	900	2.2K	ohm
OUTPUT																		
Nominal line voltage	120	120	120	240	240	240	240	240	240	240	240	240	240	240	480	480	480	V rms
Maximum line voltage	140	140	140	280	280	480	280	280	280	280	280	280	280	280	480	480	480	V rms
Minimum line voltage	12	12	12	24	24	24	24	24	24	24	24	24	24	24	24	24	24	V rms
Max peak off-state voltage	400	400	400	600	600	600	600	600	600	600	600	600	600	600	800	800	800	V peak
Max. off-state leakage cur.	2.5	2.5	2.5	2.5	4.5	2.5	4.5	4.5	4.5	4.5	4.5	4.5	4.5	4.5	4.5	4.5	4.5	mA rms
Static off-state (dv/dt)	200	200	200	200	200	200	200	200	200	200	200	—	—	—	200	200	200	V/us
Maximum on-state current*	3	3	3	3	3	3	3	3	3	3	3	3	3	3	5**	5**	5**	A rms
Minimum on-state current	50	50	50	50	50	50	50	50	50	50	50	50	50	50	50	50	50	mA rms
Maximum 1 cycle surge	100	100	100	100	100	100	100	100	100	100	100	100	100	100	100	100	100	A peak
Peak on-state voltage	1.6	1.6	1.6	1.6	1.6	1.6	1.6	1.6	1.6	1.6	1.6	1.6	1.6	1.6	1.6	1.6	1.6	V peak
Fuse rating (WRC4 only)	4A	4A	4A	4A	4A	—	4A	4A	4A	4A	4A	4A	4A	4A	5A	5A	5A	fast-acting
Response time	0.5	0.5	0.5	0.5	0.5	0.5	0.5	0.5	0.5	0.5	0.5	50 μsec max			0.5	0.5	0.5	cycle

* Derate 33mA/deg. above 25C

** 60% duty cycle

General specifications

Operating temperature range	-30 to +80°C
Storage temperature range	-40 to +100°C
Isolation	4,000 V rms
Capacitance input to output	8 pF
Line frequency range	47 to 63 Hz

Application notes

- Do not install or remove modules in live (electrically hot) circuits. High voltage may be present.
- Output connections are non-polarized.
- All units, except OM__R, and OAC--A11 are zero-cross outputs. These modules turn on irrespective of zero crossing.
- All units, except OM__C and OAC__A5 are normally open. These modules are normally closed. The OM5MS covers the 5V, 15V and 24V logic levels.

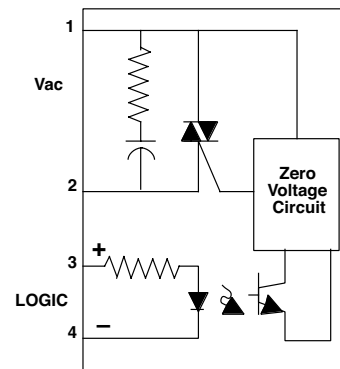

1781 and Classic

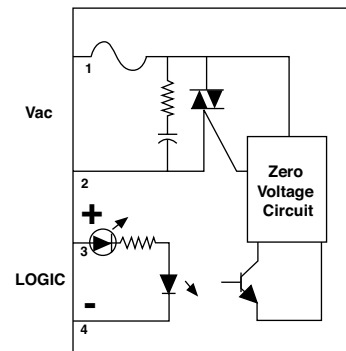

WRC4

Single-point DC Input

- To specify the WRC4 package, use the prefix “WRC4” (eg. WRC4-IA5S.)
- To specify the slim package, use the “S” suffix with the 1781 prefix (eg. 1781-IA5S.)
- To specify the mini package, use the “M” suffix with the 1781 prefix (eg. 1781-IA5M.)
- To specify the standard package, use the “Classic” part number (eg. IDC5D.)

INPUT: WRC4 and 1781 INPUT: CLASSIC	IB5S IDC5D	IBYS IDC15D	IBXS IDC24D	IT5S IDC5K	ITYS	ITXS	Units
Nominal Input Voltage	24	24	24	24	24	24	V dc
Minimum Input Voltage	3.3	3.3	3.3	3.3	3.3	3.3	V dc
Maximum Input Voltage	32	32	32	32	32	32	V dc
Nominal Input Resistance	1K	1K	1K	1K	1K	1K	ohm
Maximum Input Current	32	32	32	32	32	32	mA dc
Drop Out Current	1.0	1.0	1.0	1.0	1.0	1.0	mA dc
Allowable Off-state Current	1.0	1.0	1.0	1.0	1.0	1.0	mA dc
Allowable Off-state Voltage	2.0	2.0	2.0	2.0	2.0	2.0	V dc
OUTPUT							
Nominal Logic Voltage	5	15	24	5	15	24	V dc
Min Logic Voltage - WRC4	3	10	18	3	10	18	V dc
Min Logic Voltage - 1781	1.5	8.5	16.5	1.5	8.5	16.5	V dc
Max Logic Voltage - WRC4	7	20	32	7	20	32	V dc
Max Logic Voltage - 1781	6	19	30.5	6	19	30.5	V dc
Typical Logic Supply Current	10	10	10	10	10	10	mA dc
Max Logic Supply Current	18.5	16	14	18.5	16	14	mA dc
Max Logic Supply Leakage Cur.	10	10	10	10	10	10	μA dc
Maximum Output Voltage	30	30	30	30	30	30	V dc
Maximum Output Current	50	50	50	50	50	50	mA dc
Max Output Leakage Current	10	10	10	10	10	10	μA dc
Max Output Voltage Drop	200	200	200	200	200	200	mV dc
Maximum Turn-on Time	300	300	300	30	30	30	μsec
Maximum Turn-off Time	600	600	600	60	60	60	μsec

General specifications

Operating temperature range	-30 to +80°C
Storage temperature range	-40 to +100°C
Isolation	4,000 V rms
Capacitance input to output	8 pF

- * Derate 33mA/deg. above 25°C
- ** Derate 20mA/deg. above 60°C
- † Derate 50mA/deg. above 60°C

Application notes

- Do not install or remove modules in live (electrically hot) circuits. High voltage may be present.
- Input connections are polarized according to diagram.

1781 and Classic

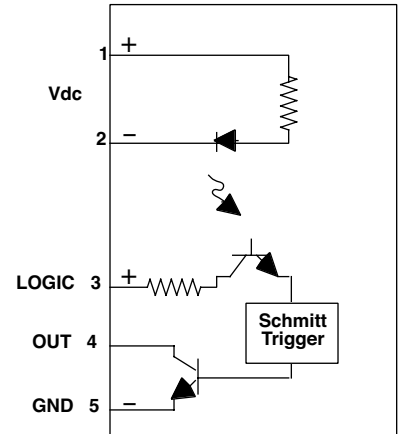

WRC4

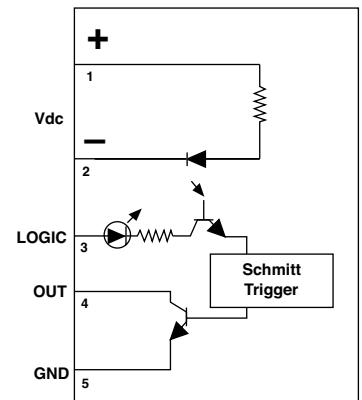

Single-point DC Output

- To specify the WRC4 package, use the prefix "WRC4" (eg. WRC4-OB5S.)
- To specify the slim package, use the "S" suffix with the 1781 prefix (eg. 1781-OB5S.)
- To specify the mini package, use the "M" suffix with the 1781 prefix (eg. 1781-OB5M.)
- To specify the standard package, use the "Classic" part number (eg. ODC5A.)

INPUT: WRC4 and 1781 INPUT: CLASSIC	OB5S ODC5	OBYS ODC15	OBXS ODC24	OC5S ODC5A	OCYS ODC15A	OCXS ODC24A	OB5S11	OBYS11	OBXS11	Units
Nominal input voltage	5	15	24	5	15	24	5	15	24	V dc
Min input volt. @ pin 3 - WRC4	4	10	18	4	10	18	4	10	18	V dc
Min input volt. @ pin 3 - 1781	2.5	8.5	16.5	2.5	8.5	16.5	2.5	8.5	16.5	V dc
Max input volt. @ pin 3 - WRC4	7.5	20	30.5	7.5	20	30.5	7.5	20	30.5	V dc
Max input volt. @ pin 3 - 1781	7.5	20	30.5	7.5	20	30.5	7.5	20	30.5	V dc
Must turn off voltage for 1781	1.0	1.0	1.0	2.0	2.0	2.0	1.0	1.0	1.0	V dc
Must turn off voltage for WRC4	2.0	2.0	2.0	2.0	2.0	2.0	2.0	2.0	2.0	V dc
Typical input current	10	10	11	10	10	11	10	10	11	mA dc
Maximum input current	27	20	15	27	20	15	27	20	15	mA dc
Nominal input resistance	240	900	2.2K	240	900	2.2K	240	900	2.2K	ohm

OUTPUT										
Nominal line voltage	24	24	24	100	100	100	24	24	24	V dc
Maximum line voltage	60	60	60	200	200	200	60	60	60	V dc
Minimum line voltage	3	3	3	5	5	5	3	3	3	V dc
Max peak off-state voltage	60	60	60	200	200	200	60	60	60	V
Max. off-state leakage cur.	1.0	1.0	1.0	2.0	2.0	2.0	0.1	0.1	0.1	mA dc
Maximum on-state current	3*	3*	3*	1**	1**	1**	3*	3*	3*	A dc
Minimum on-state current	10	10	10	10	10	10	10	10	10	mA dc
Maximum 1 second surge	5	5	5	5	5	5	5	5	5	A peak
Peak on-state volt. @ 25°C	1.5	1.5	1.5	1.5	1.5	1.5	1.5	1.5	1.5	V peak
Maximum turn-on time	50	50	50	50	50	50	50	50	50	μ sec
Nominal turn-on time	10	10	10	10	10	10	10	10	10	μ sec
Maximum Turn-off Time ‡	100	100	100	100	100	100	100	100	100	μ sec
Derating per ° above 60°C	33*	33*	33*	20**	20**	20**	33*	33*	33*	mA
Fuse rating (WRC4 only)	4	4	4	1	1	1	4	4	4	fast-acting

General specifications

Operating temperature range -30 to +80°C
 Storage temperature range -40 to +100°C
 Capacitance input to output 8 pF
 Isolation voltage 4000 Vrms

Application notes

- Do not install or remove modules in live (electrically hot) circuits. High voltage may be present.
- Output connections are polarized
- An externally located commutating diode must be installed across inductive loads.
- OF__ and OG__ modules are Mosfet-switched devices.

1781 and Classic

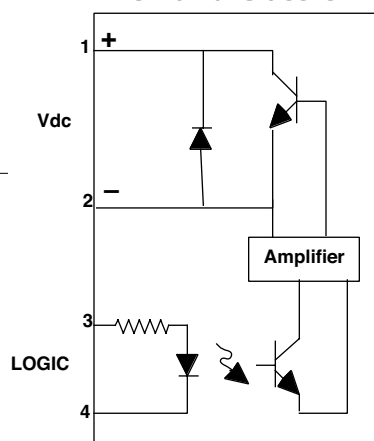

WRC4

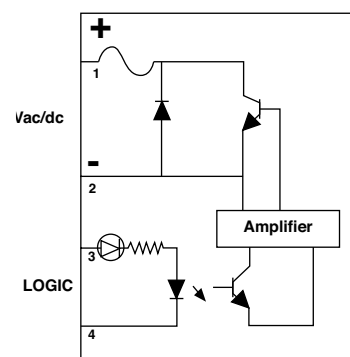

* Derate 33mA/deg. above 25°C
 ** Derate 20mA/deg above 60°C
 † Derate 50mA/deg. above 60°C
 ‡ with appropriate communicating diode

Relay Output & Watchdog

- To specify the WRC4 package, use the prefix “WRC4” (eg. WRC4-IA5S.)
- To specify the slim package, use the “S” suffix with the 1781 prefix (eg. 1781-RO5S/RC5S.)
- To specify the mini package, use the “M” suffix with the 1781 prefix (eg. 1781-RO5M/RC5M.)
- To specify the standard package, use the “Classic” part number (eg. OAC5R or OAC5R5.)

Classic & 1781-RO_S/RC_S

INPUT: WRC4 and 1781 CLASSIC	WO5S/WC5S ^{1 & 2}	RO5S/RC5S ² OAC5R(5)	ROYS/RCYS ² OAC15R(5)	ROXS/RCXS ² OAC24R(5)	Units
Nominal input voltage	5	5	15	24	V dc
Min. input volt. @ pin 3 - WRC4	4.5	4.5	10.5	19.5	V dc
Min. input volt. @ pin 3 - 1781	3.0	3.0	9	18.0	V dc
Max. input volt. @ pin 3 - WRC4	5.5	5.5	20	30.5	V dc
Max. input volt. @ pin 3 - 1781	5.5	5.5	20	30.5	V dc
Must turn off voltage	—	1.0	2.0	3.0	V dc
Typical input current	0 (4A transient)	1.3	3	2.2	mA dc
Maximum input current	0 (5A transient)	2.2	4	2.5	mA dc
Nominal input resistance	2.2K (series 0.1 uF)	2K	4.7K	10K	ohm
Typical V+ supply current	50	50	24	15	mA dc

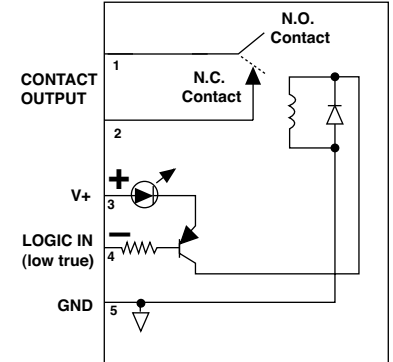

OUTPUT					
Nominal line voltage	5	5	5	5	V dc/ V rms
Maximum line voltage	100/125	100/125	100/125	100/125	V dc/ V rms
Minimum line voltage	0	0	0	0	V dc/ V rms
Max peak off-state voltage	100/125	100/125	100/125	100/125	V dc/ V rms
Max. off-state leakage cur.	0	0	0	0	mA dc
Maximum on-state current	1A, 30 Wdc, 62.5 VA	1A, 30 Wdc, 62.5 VA	1A, 30 Wdc, 62.5 VA	1A, 30 Wdc, 62.5 VA	Resistive Load
Minimum on-state current	0	0	0	0	mA
Maximum 1 second surge	2.5	2.5	2.5	2.5	A peak
Peak on-state voltage	0.25	0.25	0.25	0.25	V dc
Maximum turn-on time	2	2	2	2	ms
Maximum turn-off time	1	1	1	1	ms
Fuse rating (WRC4 only)	4A	4A	4A	4A	fast-acting

WRC4-RO_S/RC_S

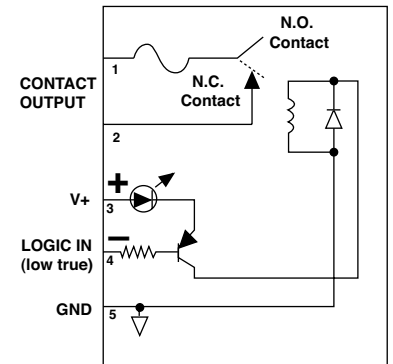

1781-WO5S/WC5S

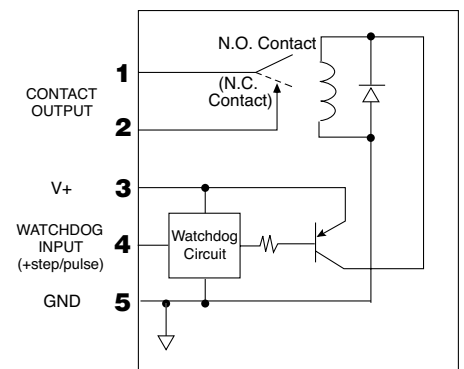

¹ Timer Values: xxx = value in millisecs. xxs = value in seconds
 40, 80, 125, 250, 500 ms 4, 8, 16, 32 sec.

Examples: 1781-WO5S-500 has N.O. contacts & 500 ms watchdog
 1781-WC5S-4S has N.C. contacts & 4 sec. watchdog

² 1781-RO5S/ROXS & 1781-WO5S contacts normally open (N/O)
 1781-RC5S/RCXS & 1781-WC5S contacts normally closed (N/C)

General specifications

Operating Temperature Range	-30 to +80°C
Isolation Voltage	1000 V rms
Capacitance Input to Output	8 pF

Application notes

- Relay & watchdog modules are rated for resistive loads only.

INPUT	IA5Q	IM5Q	IN5Q	Units
Nominal Input Voltage	120	240	24/48	Vrms/Vdc
Minimum Input Voltage	90	180	10	Vrms/Vdc
Maximum Input Voltage	140	280	60	Vrms/Vdc
Maximum Input Current*	10	8	30	mA rms
Drop Out Current	2.5	1.5	1.0	mA rms
Allowable Off-state Current	3.0	2.0	1.0	mA rms
Allowable Off-state Voltage	50	120	2	Vrms/Vdc

OUTPUT	IA5Q	IM5Q	IN5Q	Units
Nominal Logic Supply Voltage	5.0	5.0	5.0	V dc
Minimum Logic Voltage	4.5	4.5	4.5	V dc
Maximum Logic Voltage	6.0	6.0	6.0	V dc
Typical Logic Supply Current*	10	10	10	mA dc
Max. Logic Supply Current**	14.5	14.5	14.5	mA dc
Max. Logic Sup. Leak. Current**	20	20	20	μ A dc
Maximum Output Voltage	30	30	30	V dc
Maximum Output Current	50	50	50	mA dc
Max. Output Leakage Current**	20	20	20	μ A dc
Max. Output Voltage Drop†	200	200	200	mV dc
Maximum Turn-on Time (ac)	20	20	20	msec
Maximum Turn-off Time (ac)	30	30	30	msec
Maximum Turn-on Time (dc)	1	1	1	msec
Maximum Turn-off Time (dc)	1	1	1	msec

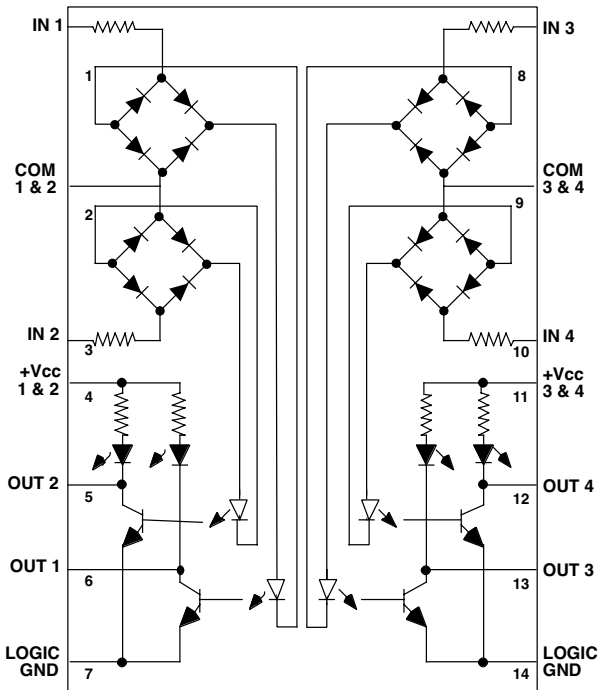

• Infrared Coupler LED
 • Red Indicator LED
 • Equivalent Circuit Only
 • Negative True Logic

* @ nominal voltage
 ** @ maximum logic voltage
 † @ maximum output current

General specifications

Operating temperature range -30 to +80°C
 Storage temperature range -40 to +100°C
 Isolation 4,000 V rms
 Capacitance input to output 8 pF
 Line frequency range 47 to 63 Hz

* @nominal input voltage (ac)

Application notes

- Do not install or remove modules in live (electrically hot) circuits. High voltage may be present.
- Input connections are non-polarized.
- The controlled voltage on the output pins (OUT 1,2,3, and 4) cannot exceed 3 V dc higher than +Vcc. This is a limitation of the reverse breakdown voltage of the status indicator LED's.
- An externally located diode (forward biased) can be installed in series with +Vcc 1 & 2 (pin 4) or +Vcc 3 & 4 (pin 11) of the module to extend the output control voltage to a maximum of 30 V dc. An externally located diode (forward biased) can be installed in series with the + terminal of a quad backplane to extend the output control voltage to a maximum of 30 V dc.

INPUT	OA5Q	OM5Q	Units
Nominal Input Voltage	5	5	Vdc
Minimum Input Voltage	4.0	4.0	Vdc
Maximum Input Voltage	6.0	6.0	Vdc
Drop Out Voltage	1.0	1.0	V dc
Maximum Input Current	15	15	mA dc
Typical Input Current	10	10	mA dc
Nominal Input Resistance	240	240	Ω

OUTPUT	OA5Q	OM5Q	Units
Nominal Line Voltage	120	240	V rms
Maximum Line Voltage	140	280	V rms
Minimum Line Voltage	12	24	V rms
Maximum Off-state Leakage	2.5	4.5	mA rms
Static Off-state (dv/dt)	200	200	V/ μ sec
Maximum On-state Current*	3.0	3.0	A rms
Minimum On-state Current	50	50	mA rms
Maximum 1-cycle Surge	100	100	A peak
Peak On-state Voltage	1.6	1.6	V peak
Response Time	0.5	0.5	cycle

* Derate 40 mA/°C above 20°C. When operating in I/O racks that share a common fuse between two channels, maximum on-state current must not exceed a total of 3.75 A rms @ 20° ambient for both channels.

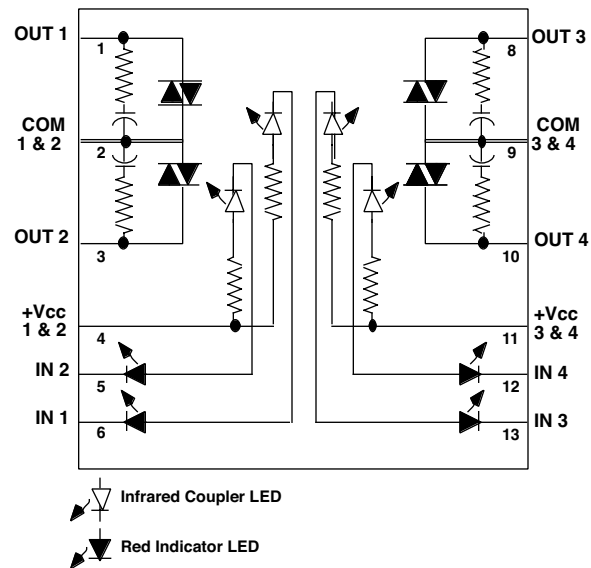

General specifications

Operating temperature range -30 to +80°C
 Storage temperature range -40 to +100°C
 Isolation 4,000 V rms
 Capacitance input to output 8 pF
 Line frequency range 47 to 63 Hz

Application notes

- Do not install or remove modules in live (electrically hot) circuits. High voltage may be present.
- Output connections are non-polarized.

Quad DC Input

INPUT	IB5Q	IT5Q	Units
Nominal Input Voltage	24	24	Vdc
Maximum Input Voltage	32	32	Vdc
Minimum Input Voltage	3.3	3.3	Vdc
Input Resistance	1	1	KΩ
Drop Out Current	1.0	1.0	mA dc
Maximum Input Current*	32	32	mA dc
Allowable Off-state Input	1.0	1.0	mA dc
Allowable Off-state Voltage	2.0	2.0	V dc
Maximum Turn-on Time	300	30	μ sec
Maximum Turn-off Time	600	600	μ sec

* @ maximum input voltage

OUTPUT	IB5Q	IT5Q	Units
Nominal Logic Supply Voltage	5	5	V dc
Minimum Logic Voltage	4.5	4.5	V dc
Maximum Logic Voltage	6.0	6.0	V dc
Typical Logic Supply Current*	10	10	mA dc
Maximum Logic Supply Current**	14.5	14.5	mA dc
Max. Logic Supply Leakage Current**	20	20	μA dc
Maximum Output Voltage	30	30	V dc
Maximum Output Current	50	50	mA dc
Maximum Output Leakage Current**	20	20	μA dc
Maximum Output Voltage Drop†	200	200	mV dc

* @ nominal voltage

** @ maximum logic voltage

† @ maximum output current

General specifications

Operating temperature range -30 to +80°C
 Storage temperature range -40 to +100°C
 Isolation 4,000 V rms
 Capacitance input to output 8 pF

* @nominal input voltage

Application notes

- Do not install or remove modules in live (electrically hot) circuits. High voltage may be present.
- Input connections are polarized.
- The controlled voltage on the output pins (out 1,2,3, and 4) cannot exceed 3 V dc higher than +Vcc. This is a limitation of the reverse breakdown voltage of the status indicator LED's.
- An externally located diode (forward biased) can be installed in series with the +Vcc 1 & 2 pin (pin 4) or +Vcc 3 & 4 (pin 11) of the module to extend the output control voltage to a maximum of 30 V dc. An externally located diode (forward biased) can be installed in series with the + terminal of a quad backplane to extend the output control voltage to a maximum of 30 V dc.

1781-IB5Q

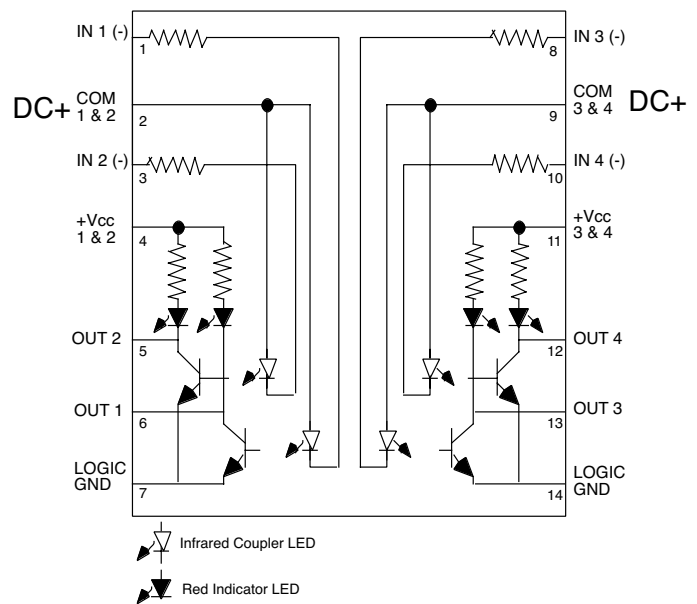

1781-IT5Q

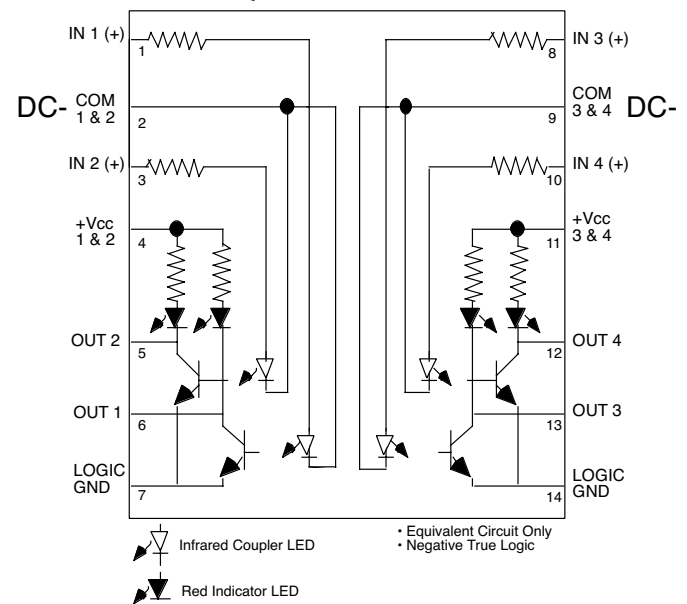

INPUT	OB5Q	OC5Q	Units	RO5Q/RC5Q ¹
Nominal Input Voltage	5	5	V dc	5 V dc
Minimum Input Voltage	4.0	4.0	V dc	4.0 V dc
Maximum Input Voltage	6.0	6.0	V dc	6.0 V dc
Drop Out Voltage	1.0	1.0	V dc	1.0 V dc
Maximum Input Current	15	15	mA dc	27 mA dc
Typical Input Current	10	10	mA dc	10 mA dc
Nominal Input Resistance	240	240	Ω	240 Ω
Typical V+ Current	—	—	—	48 mA dc/channel on
Isolation	4000	4000	V rms	1000 V rms

General specifications

Operating temperature range -30 to +80°C
 Storage temperature range -40 to +100°C
 Capacitance input to output 8 pF
 Isolation voltage 4000 Vrms

Application notes

- Do not install or remove modules in live (electrically hot) circuits. High voltage may be present.
- Solid-state output connections are polarized.
- An externally located communicating diode must be installed across inductive loads.
- Relay modules for resistive loads only.
- Relay output connections are not polarized.

OUTPUT	OB5Q	OC5Q	Units	RO5Q/RC5Q ¹
Maximum Line Voltage	60	200	V dc	110 V dc/125 V ac
Minimum Line Voltage	3.0	5.0	V dc	—
Maximum Off-state Voltage	60	200	V dc	110 V dc/125 V dc
Maximum Off-state Leakage	1.0	2.0	mA dc	—
Maximum On-state Current	3.0*	1.0**	A dc	1A, 30 W dc 62.5 V A (resistive load)
Minimum On-state Current	10	10	mA dc	—
Maximum 1-second Surge	5	5	A dc	2.5 A (resistive load)
Peak On-state Voltage @ 25°C	1.5	1.5	V dc	0.25 V dc
Maximum Turn-on Time	50	50	μ sec	2 msec (20 cpm)
Maximum Turn-off Time	100	100	μ sec	1 msec (20 cpm)

* Derate 40 mA/°C above 20°C. When operating in I/O racks that share a common fuse between two channels, maximum on-state current must not exceed a total of 3.75 A rms @ 20° ambient for both channels.

** Derate 20 mA/°C above 60°C. When operating in I/O racks that share a common fuse between two channels, maximum on-state current must not exceed a total of 3.75 A rms @ 20° ambient for both channels.

1781-OB5Q, 1781-OC5Q

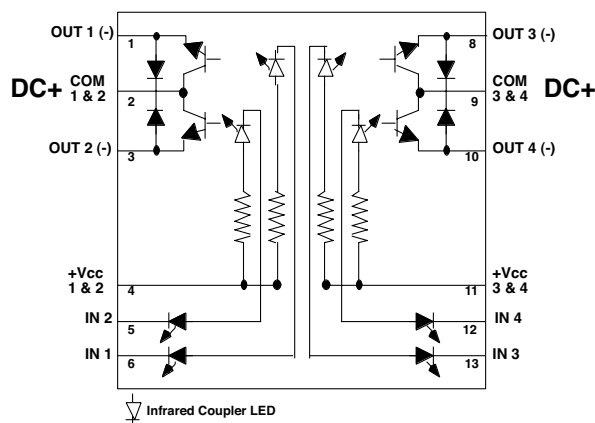

1781-RO5Q, 1781-RC5Q

