



**DS7810/DS8810 Quad 2-Input TTL-MOS Interface Gate**  
**DS7811/DS8811 Quad 2-Input TTL-MOS Interface Gate**  
**DS7812/DS8812 Hex TTL-MOS Inverter**

**General Description**

These Series 54/74 compatible gates are high output voltage versions of the DM5401/DM7401 (SN5401/SN7401), DM5403/DM7403 (SN5403/SN7403), and DM5405/DM7405 (SN5405/SN7405). Their open-collector outputs may be "pulled-up" to +14 volts in the logical "1" state thus providing guaranteed interface between TTL and MOS logic levels.

In addition the devices may be used in applications where it is desirable to drive low current relays or lamps that require up to 14 volts.

**Schematic and Connection Diagrams**

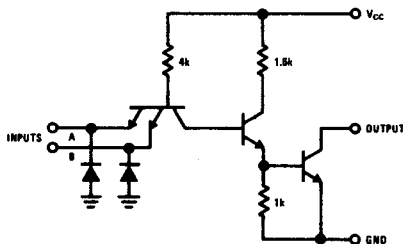

DS7810/DS8810, DS7811/DS8811

Dual-In-Line Package

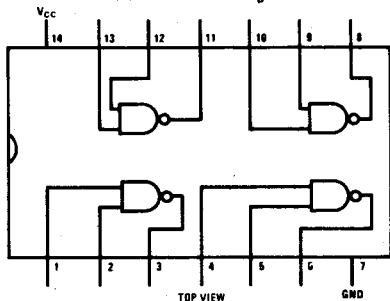

Order Number DS7810J, DS8810J,  
or DS8810N  
See NS Package J14A or N14A

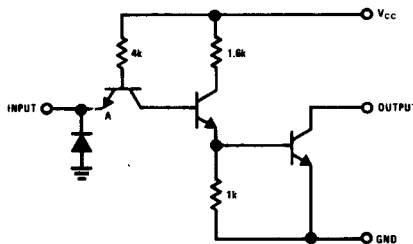

DS7812/DS8812

Dual-In-Line Package

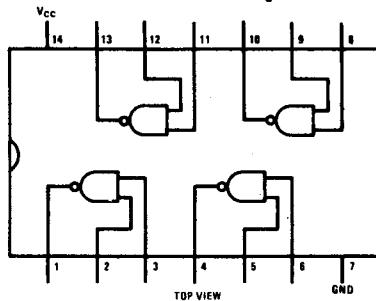

Order Number DS7811J, DS8811J,  
DS7811W or DS8811N  
See NS Package J14A, N14A or W14A

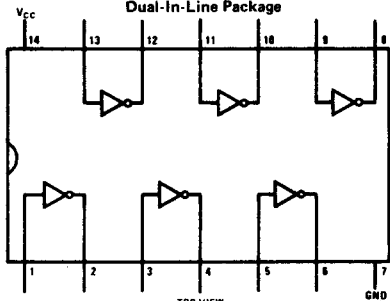

Order Number DS7812J, DS8812J,  
DS7812W or DS8812N  
See NS Package J14A, N14A or W14A

## Absolute Maximum Ratings (Note 1)

V <sub>CC</sub>	7V
Input Voltage	5.5V
Output Voltage	14V
Storage Temperature Range	-65°C to +150°C
Maximum Power Dissipation* at 25°C	
Cavity Package	1254 mW
Molded Package	1106 mW
Lead Temperature (Soldering, 10 seconds)	300°C

\*Derate cavity package 8.36 mW/°C above 25°C; derate molded package 8.85 mW/°C above 25°C.

## Operating Conditions

	MIN	MAX	UNITS
Supply Voltage (V <sub>CC</sub> )			
DS78XX	4.5	5.5	V
DS88XX	4.75	5.25	V
Temperature (T <sub>A</sub> )			
DS78XX	-55	+125	°C
DS88XX	0	+70	°C

## Electrical Characteristics (Notes 2 and 3)

PARAMETER	CONDITIONS	MIN	TYP	MAX	UNITS
V <sub>CLAMP</sub>	Input Diode Clamp Voltage V <sub>CC</sub> = 5.0V, T <sub>A</sub> = 25°C, I <sub>IN</sub> = -12 mA			-1.5	V
V <sub>IH</sub>	Logical "1" Input Voltage V <sub>CC</sub> = Min	2.0			V
V <sub>IL</sub>	Logical "0" Input Voltage V <sub>CC</sub> = Min			0.8	V
I <sub>OH</sub>	Logical "1" Output Current V <sub>CC</sub> = Min, V <sub>IN</sub> = 0.8V V <sub>OUT</sub> = 10V, V <sub>IN</sub> = 0.0V			250 40	μA μA
I <sub>OL</sub>	Logical "0" Output Current V <sub>CC</sub> = Min, V <sub>IN</sub> = 2.0V, V <sub>OUT</sub> = 0.4V	16			mA
V <sub>OH</sub>	Logical "1" Output Breakdown Voltage V <sub>CC</sub> = Min, V <sub>IN</sub> = 0V, I <sub>OUT</sub> = 1 mA	14			V
V <sub>OL</sub>	Logical "0" Output Voltage V <sub>CC</sub> = Min, V <sub>IN</sub> = 2.0V, I <sub>OUT</sub> = 16 mA			0.4	V
I <sub>IH</sub>	Logical "1" Input Current V <sub>CC</sub> = Max, V <sub>IN</sub> = 2.4V V <sub>IN</sub> = 5.5V			40 1	μA mA
I <sub>IL</sub>	Logical "0" Input Current V <sub>CC</sub> = Max, V <sub>IN</sub> = 0.4V			-1.6	mA
I <sub>CC(MAX)</sub>	Logical "0" Supply Current (Each Gate) V <sub>CC</sub> = Max, V <sub>IN</sub> = 5.0V		3.0	5.1	mA
I <sub>CC(MIN)</sub>	Logical "1" Supply Current (Each Gate) V <sub>CC</sub> = Max, V <sub>IN</sub> = 0V		1.0	1.8	mA

## Switching Characteristics T<sub>A</sub> = 25°C, V<sub>CC</sub> = 5V

PARAMETER	CONDITIONS	MIN	TYP	MAX	UNITS
t <sub>pd0</sub>	Propagation Delay Time to a Logical "0"	4	12	18	ns
t <sub>pd1</sub>	Propagation Delay Time to a Logical "1"	18	29	45	ns

C<sub>OUT</sub> = 15 pF, R<sub>L</sub> = 1k

**Note 1:** "Absolute Maximum Ratings" are those values beyond which the safety of the device cannot be guaranteed. Except for "Operating Temperature Range" they are not meant to imply that the devices should be operated at these limits. The table of "Electrical Characteristics" provides conditions for actual device operation.

**Note 2:** Unless otherwise specified min/max limits apply across the -55°C to +125°C temperature range for the DS7810, DS7811, and DS7812 and across the 0°C to +70°C range for the DS8810, DS8811, and DS8812.

**Note 3:** All currents into device pins shown as positive, out of device pins as negative, out of device pins shown as positive, out of device pins as negative, all voltages referenced to ground unless otherwise noted. All values shown as max or min on absolute value basis.

## Typical Applications

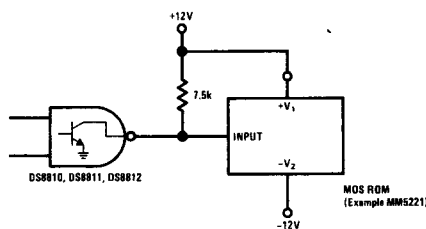
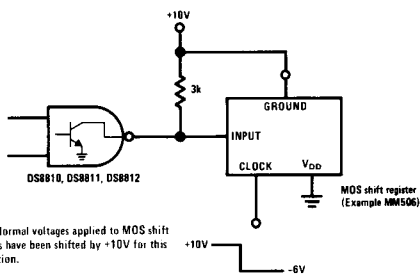

### AC Test Circuit and Switching Time Waveforms

