

**Three Phase Inverter Module in MTP Package
 1200V NPT IGBT & Hexfred™ Diodes**

Features

- Gen. 5 NPT 1200V IGBT Technology
- HEXFRED™ Diode with UltraSoft Reverse Recovery
- Very Low Conduction and Switching Losses
- Optional SMT Thermistor (NTC)
- Aluminum Oxide DBC
- Very Low Stray Inductance Design for High Speed Operation
- Short Circuit 10μS
- Square RBSOA

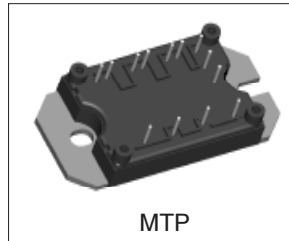

$V_{CES} = 1200V$
$I_C = 15A, T_C=100^{\circ}C$
$t_{sc} > 10\mu s, T_J=150^{\circ}C$
$V_{CE(on)} \text{ typ.} = 2.51V$

Benefits

- Optimized for Inverter Motor Drive Applications
- Operating Frequencies up to 20 kHz
- Low EMI, requires Less Snubbing
- Direct Mounting to Heatsink
- PCB Solderable Terminals
- Very Low Junction-to-Case Thermal Resistance

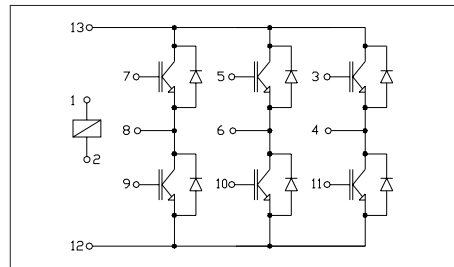

Absolute Maximum Ratings

Parameters		Max	Units
V_{CES}	Collector-to-Emitter Voltage	1200	V
I_C	Continuous Collector Current	@ $T_C = 25^{\circ}C$	30
		@ $T_C = 100^{\circ}C$	17
I_{CM}	Pulsed Collector Current	60	
I_{LM}	Peak Switching Current	60	
I_F	Diode Continuous Forward Current	@ $T_C = 100^{\circ}C$	15
I_{FM}	Peak Diode Forward Current	30	
V_{GE}	Gate-to-Emitter Voltage	± 20	V
V_{ISOL}	RMS Isolation Voltage, Any Terminal to Case, $t = 1 \text{ min}$	2500	
P_D	Maximum Power Dissipation (including diode and IGBT)	@ $T_C = 25^{\circ}C$	187
		@ $T_C = 100^{\circ}C$	75

Electrical Characteristics @ T_J = 25°C (unless otherwise specified)

Parameters	Min	Typ	Max	Units	Test Conditions
V _{(BR)CES} Collector-to-Emitter Breakdown Voltage	1200	-	-	V	V _{GE} = 0, I _C = 250μA
ΔV _{(BR)CES} /ΔT _J Temperature coeff of V _{(BR)CES}	-	1.11	-	V/°C	V _{GE} = 0, I _C = 1mA
V _{CE(on)} Collector-to-Emitter Voltage	-	2.51	2.70	V	V _{GE} = 15V, I _C = 15A
	-	3.36	3.66		V _{GE} = 15V, I _C = 30A
	-	2.94	3.16		V _{GE} = 15V, I _C = 15A, T _J = 125°C
	-	4.12	4.46		V _{GE} = 15V, I _C = 30A, T _J = 125°C
V _{GE(th)} Gate Threshold Voltage	4	-	6		I _C = 250μA
ΔV _{GE(th)} /ΔT _J Temperature Coeff. of Threshold Voltage	-	- 10	-	mV/°C	V _{CE} = V _{GE} , I _C = 1mA
g _{fe} Forward Transconductance	-	12	-	S	V _{CE} = 25V, I _C = 15A
I _{CES} Collector-to-Emitter Leaking Current	-	-	250	μA	V _{GE} = 0, V _{CE} = 1200V
	-	-	1000		V _{GE} = 0, V _{CE} = 1200V, T _J = 125°C
V _{FM} Diode Forward Voltage Drop	-	2.13	2.58	V	I _F = 15A, V _{GE} = 0
	-	2.70	3.33		I _F = 30A, V _{GE} = 0
	-	2.27	2.75		I _F = 15A, V _{GE} = 0, T _J = 125°C
	-	3.06	3.76		I _F = 30A, V _{GE} = 0, T _J = 125°C
I _{GES} Gate-to-Emitter Leakage Current	-	-	± 250	nA	V _{GE} = ± 20V

Switching Characteristics @ T_J = 25°C (unless otherwise specified)

Parameters	Min	Typ	Max	Units	Test Conditions
Q _g Total Gate Charge (turn-on)	-	98	146	nC	I _C = 15A
Q _{ge} Gate-Emitter Charge (turn-on)	-	12	17		V _{CC} = 600V
Q _{gc} Gate-Collector Charge (turn-on)	-	46	69		V _{GE} = 15V
E _{on} Turn-On Switching Loss	-	990	1485	μJ	I _C = 15A, V _{CC} = 600V, V _{GE} = 15V
E _{off} Turn-Off Switching Loss	-	827	1241		R _g = 10Ω, L = 500μH, T _J = 25°C
E _{ts} Total Switching Loss	-	1817	2726		Energy losses include tail & diode reverse recovery
E _{on} Turn-On Switching Loss	-	1352	2028	μJ	I _C = 15A, V _{CC} = 600V, V _{GE} = 15V
E _{off} Turn-Off Switching Loss	-	1138	1707		R _g = 10Ω, L = 500μH, T _J = 125°C
E _{ts} Total Switching Loss	-	2490	3735		Energy losses include tail & diode reverse recovery
t _{d(on)} Turn-On Delay Time	-	95	143	ns	I _C = 15A, V _{CC} = 600V, V _{GE} = 15V
t _r Rise Time	-	18	27		L = 500μH, L _S = 100nH
t _{d(off)} Turn-off delay Time	-	134	200		R _g = 10Ω, T _J = 125°C
t _f Fall time	-	227	341		
RBSOA Reverse BIAS Safe Operating Area	FULL SQUARE				
SCSOA Schort Circuit Safe Operating Area	10	-	-	μs	V _{CC} = 600V, V _{GE} = +15V to 0 T _J = 150°C, V _P = 1200V, R _G = 10Ω
C _{ies} Input Capacitance	-	1302	1953	pF	V _{GE} = 0
C _{oes} Output Capacitance	-	717	1076		V _{CC} = 30V
C _{res} Reverse Transfer Capacitance	-	38	57		f = 1.0 MHz
E _{rec} Diode Reverse Recovery Energy	-	819	-	μJ	I _C = 15A, V _{CC} = 600V, V _{GE} = 15V
t _{rr} Diode Reverse Recovery Time	-	96	-	ns	L = 500μH, L _S = 100nH
I _{rr} Diode Peak Reverse Current	-	35	-	A	R _g = 10Ω, T _J = 125°C

Thermistor Specifications (T code only)

Parameters	Min	Typ	Max	Units	Test Conditions
R ₀ ⁽¹⁾ Resistance		30		kΩ	T ₀ = 25°C
β ⁽¹⁾⁽²⁾ Sensitivity index of the thermistor material		4000		K	T ₀ = 25°C T ₁ = 85°C

⁽¹⁾ T₀, T₁ are thermistor's temperatures

$$\frac{R_0}{R_1} = \exp \left[\beta \left(\frac{1}{T_0} - \frac{1}{T_1} \right) \right]$$

Thermal- Mechanical Specifications

Parameters	Min	Typ	Max	Units	
T _J Operating Junction Temperature Range	- 40		150	°C	
T _{STG} Storage Temperature Range	- 40		125		
R _{thJC} Junction-to-Case	IGBT		1.1	°C/W	
	Diode		1.7		
	Module	-	0.50		-
R _{thCS} Case-to-Sink (Heatsink Compound Thermal Conductivity = 1 W/mK)	Module	-	0.1		-
T Mounting Torque	-	-	4		Nm
Weight	-	65	-	g	

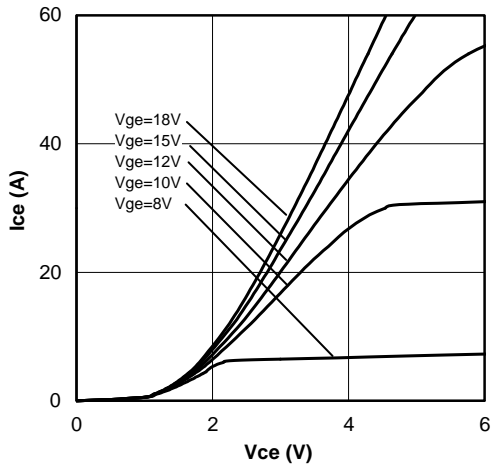

Fig 1. Typical Output Characteristics
 $T_J = 25^\circ\text{C}$

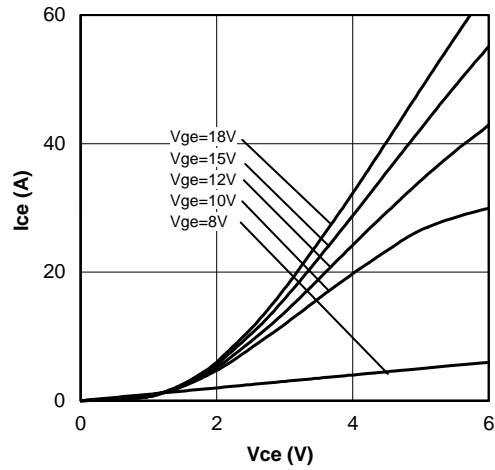

Fig 2. Typical Output Characteristics
 $T_J = 125^\circ\text{C}$

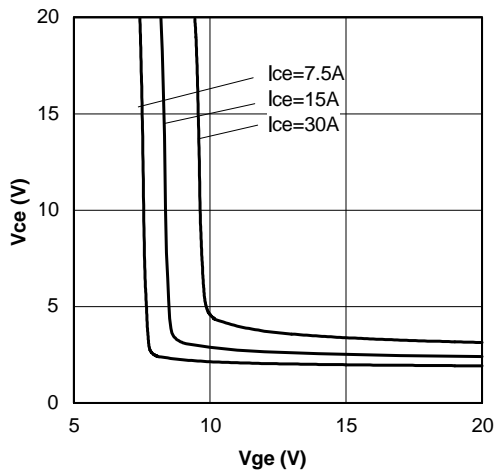

Fig 3. Typical V_{CE} vs. V_{GE}
 $T_J = 25^\circ\text{C}$

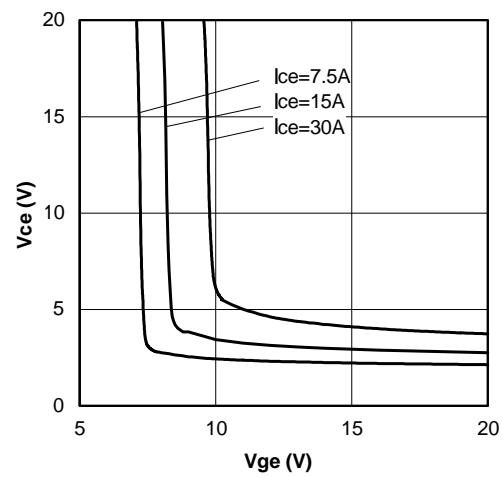

Fig 4. Typical V_{CE} vs. V_{GE}
 $T_J = 125^\circ\text{C}$

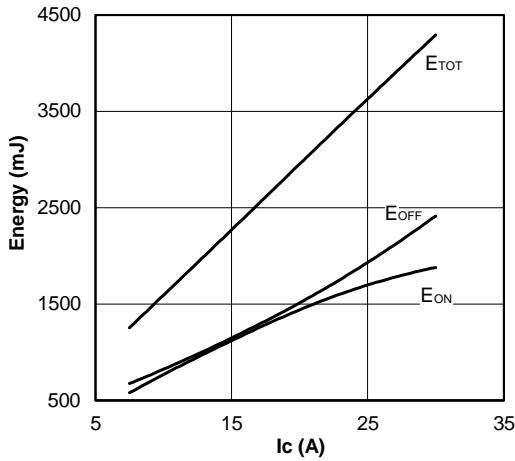

Fig 5. Typ. Energy Loss vs. I_C
 $T_J=125^\circ\text{C}$; $L=500\mu\text{H}$; $V_{CE}=600\text{V}$
 $R_G=10\Omega$; $V_{GE}=15\text{V}$

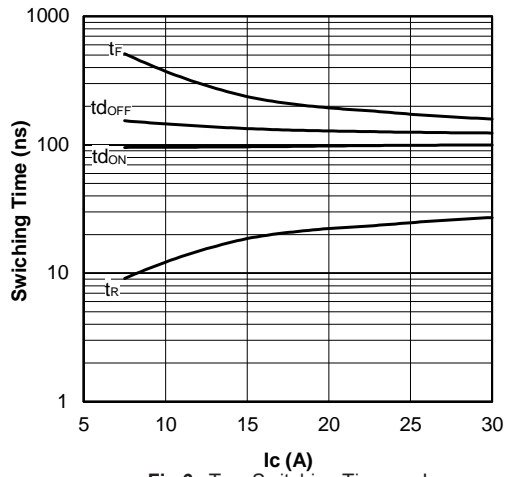

Fig 6. Typ. Switching Time vs. I_C
 $T_J=125^\circ\text{C}$; $L=500\mu\text{H}$; $V_{CE}=600\text{V}$
 $R_G=10\Omega$; $V_{GE}=15\text{V}$

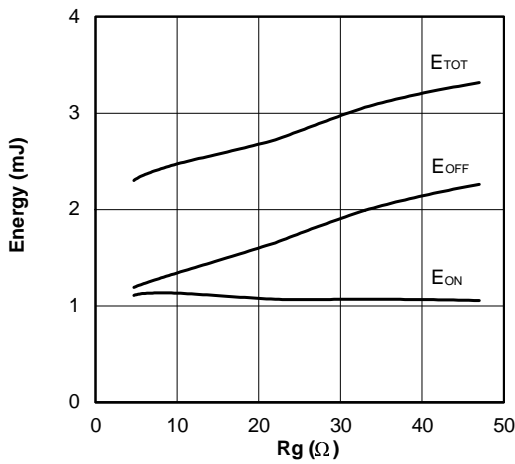

Fig 7. Typ. Energy Loss vs. R_G
 $T_J=125^\circ\text{C}$; $L=500\mu\text{H}$; $V_{CE}=600\text{V}$
 $I_C=15\text{A}$; $V_{GE}=15\text{V}$

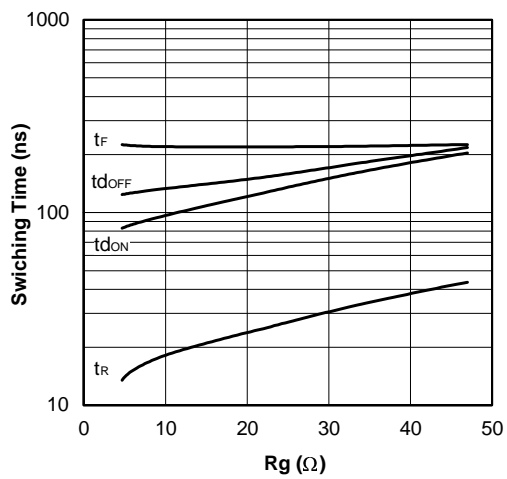

Fig 8. Typ. Switching Time vs. R_G
 $T_J=125^\circ\text{C}$; $L=500\mu\text{H}$; $V_{CE}=600\text{V}$
 $I_C=15\text{A}$; $V_{GE}=15\text{V}$

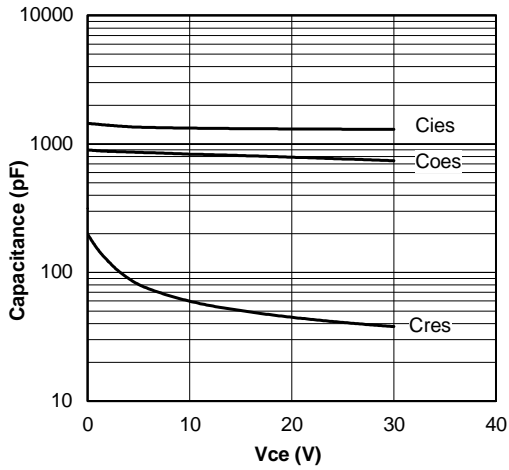

Fig 9. Typ. Capacitance vs. V_{CE}
 $V_{GE} = 0$; $f = 1\text{MHz}$

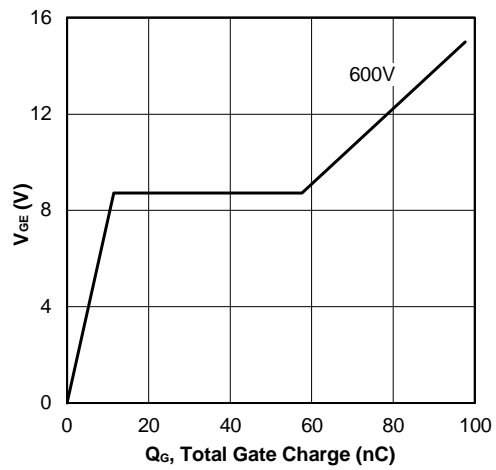

Fig 10. Typ. Gate Charge vs. V_{GE}
 $I_{CE} = 15\text{A}$

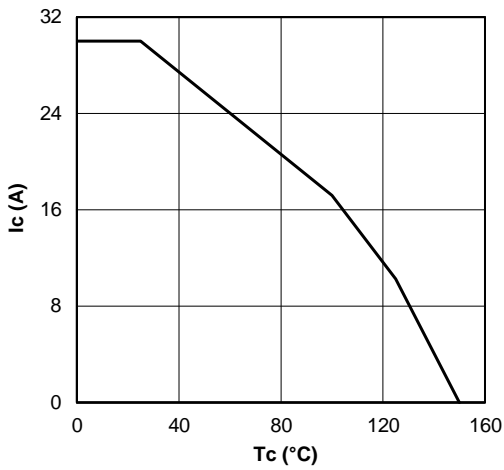

Fig 11. Maximum DC Collector Current vs.
 Case Temperature

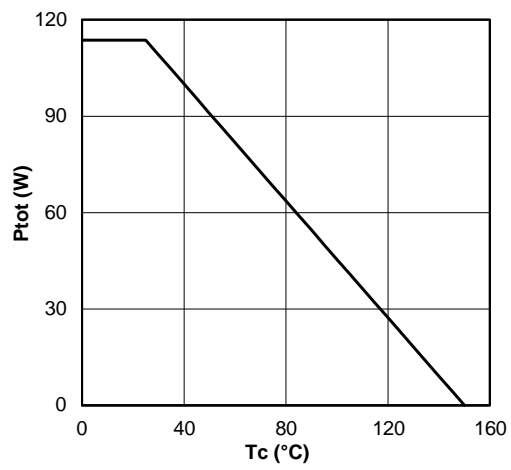

Fig 12. Power Dissipation vs.
 Case Temperature (IGBT ONLY)

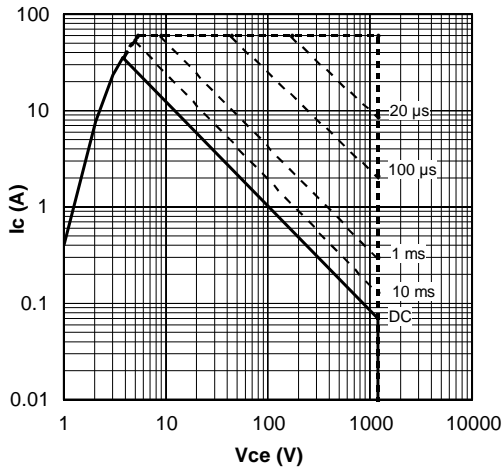

Fig. 13 - Forward SOA
 $T_C = 25^\circ\text{C}; T_J \leq 150^\circ\text{C}$

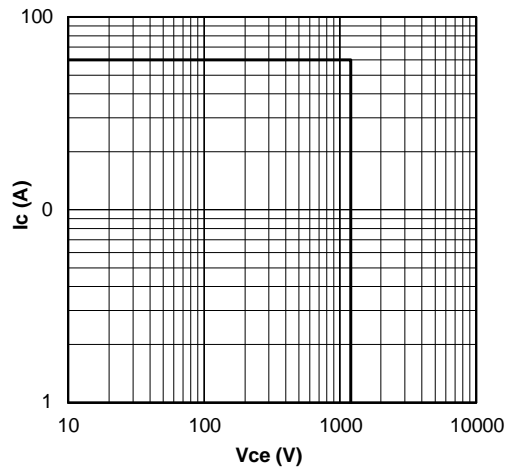

Fig. 14 - Reverse Bias SOA
 $T_J = 150^\circ\text{C}; V_{GE} = 15\text{V}$

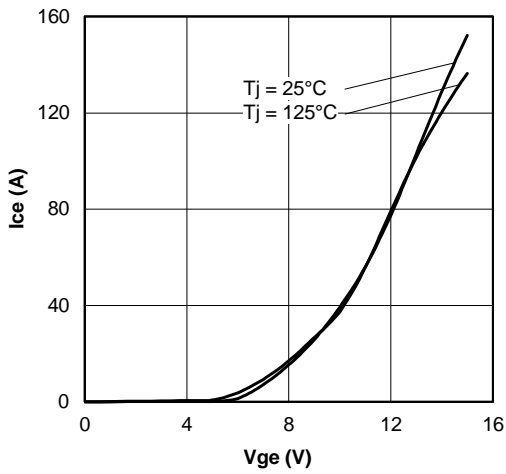

Fig. 15 - Typ. Transfer Characteristics
 $V_{CE} = 50\text{V}; t_p = 10\mu\text{s}$

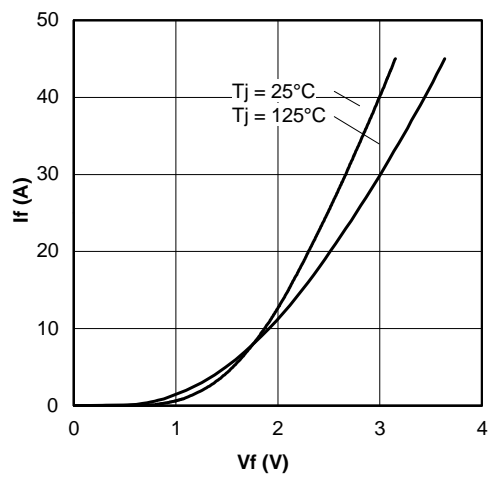

Fig. 16 - Typ. Diode Forward Characteristics
 $t_p = 80\mu\text{s}$

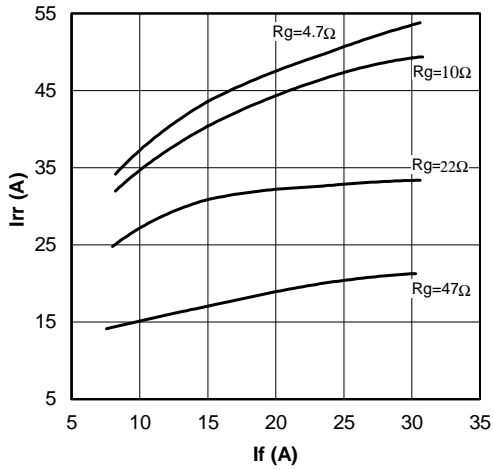

Fig. 17 - Typical Diode I_{RR} vs. I_F
 $T_J = 125^\circ\text{C}$

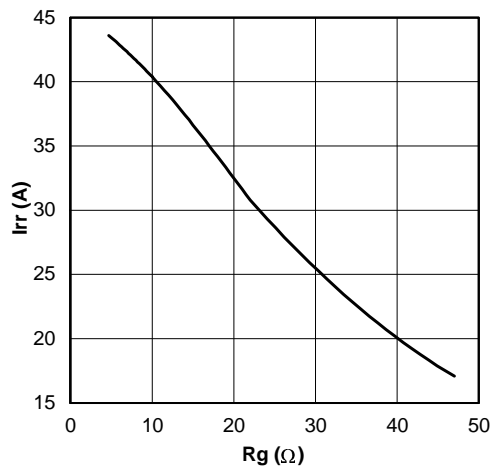

Fig. 18 - Typical Diode I_{RR} vs. R_G
 $T_J = 125^\circ\text{C}$; $I_F = 10\text{A}$

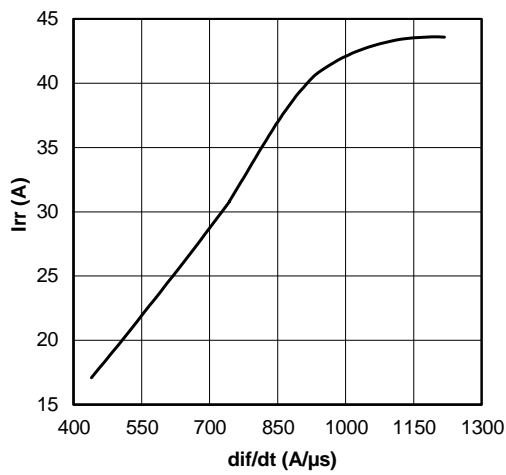

Fig. 19- Typical Diode I_{RR} vs. di_F/dt ; $V_{CC} = 600\text{V}$;
 $V_{GE} = 15\text{V}$; $I_{CE} = 10\text{A}$; $T_J = 125^\circ\text{C}$

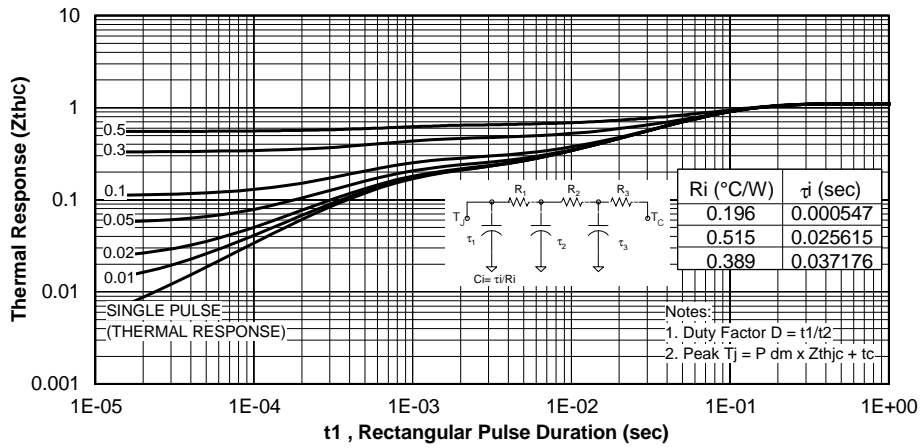

Fig 20. Maximum Transient Thermal Impedance, Junction-to-Case (IGBT)

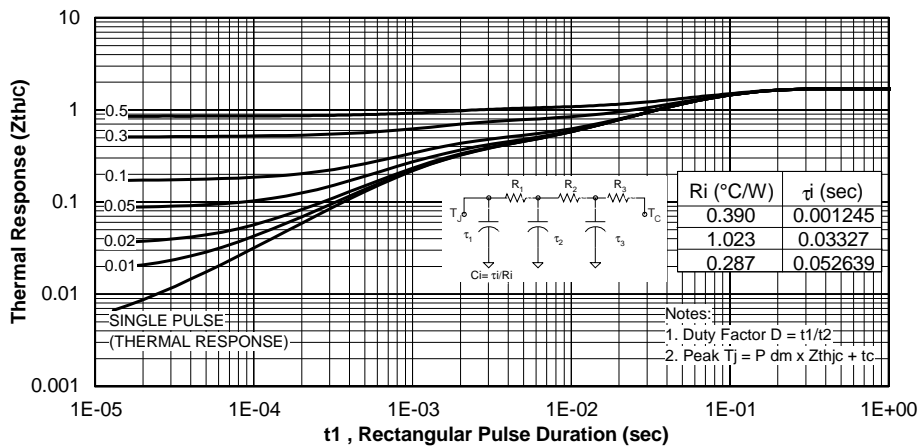
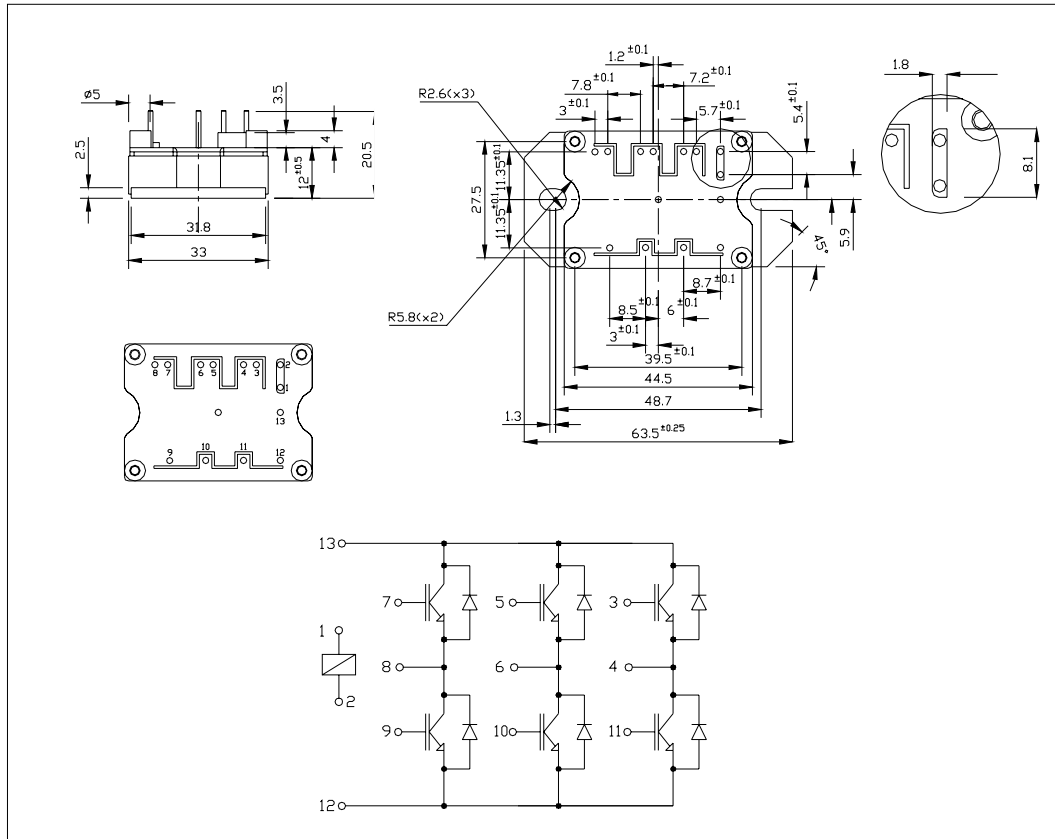

Fig 21. Maximum Transient Thermal Impedance, Junction-to-Case (DIODE)

Outline Table



Ordering Information Table

Device Code	
GB	15
XP	120
K	-
①	②
③	④
⑤	⑥

1	-	IGBT Module
2	-	Nominal Current rating (15 = 15A)
3	-	Circuit Configuration (XP = Three Phase Inverter)
4	-	Voltage code (120 = 1200V)
5	-	Speed/ Type (K = Ultra Fast IGBT-Inverter Motor Drive Application)
6	-	Special Option

Empty = no special option
 T = Thermistor

Data and specifications subject to change without notice.
This product has been designed and qualified for Industrial Level.
Qualification Standards can be found on IR's Web site.

International
IOR Rectifier

IR WORLD HEADQUARTERS: 233 Kansas St., El Segundo, California 90245, USA Tel: (310) 252-7105
TAC Fax: (310) 252-7309
03/02



Disclaimer

All product specifications and data are subject to change without notice.

Vishay Intertechnology, Inc., its affiliates, agents, and employees, and all persons acting on its or their behalf (collectively, "Vishay"), disclaim any and all liability for any errors, inaccuracies or incompleteness contained herein or in any other disclosure relating to any product.

Vishay disclaims any and all liability arising out of the use or application of any product described herein or of any information provided herein to the maximum extent permitted by law. The product specifications do not expand or otherwise modify Vishay's terms and conditions of purchase, including but not limited to the warranty expressed therein, which apply to these products.

No license, express or implied, by estoppel or otherwise, to any intellectual property rights is granted by this document or by any conduct of Vishay.

The products shown herein are not designed for use in medical, life-saving, or life-sustaining applications unless otherwise expressly indicated. Customers using or selling Vishay products not expressly indicated for use in such applications do so entirely at their own risk and agree to fully indemnify Vishay for any damages arising or resulting from such use or sale. Please contact authorized Vishay personnel to obtain written terms and conditions regarding products designed for such applications.

Product names and markings noted herein may be trademarks of their respective owners.