

DO NOT SCALE FROM THIS PRINT

DESIGNED & DIMENSIONED IN INCHES[MILLIMETERS]

PRF06-P-C-EP-270A-RS

SERIES
-06: NTPE

GENDER
-P: PLUG

TYPE
-C: CABLE

FINISH
-EP: 50µ" EXTRA HEAVY GOLD CENTER CONTACT, PASSIVATED OUTER CONTACT

TERMINATION
-S: SOLDER CLAMP

ORIENTATION
-R: RIGHT ANGLE

CABLE TYPE
-270A: DF218 DYNAWAVE

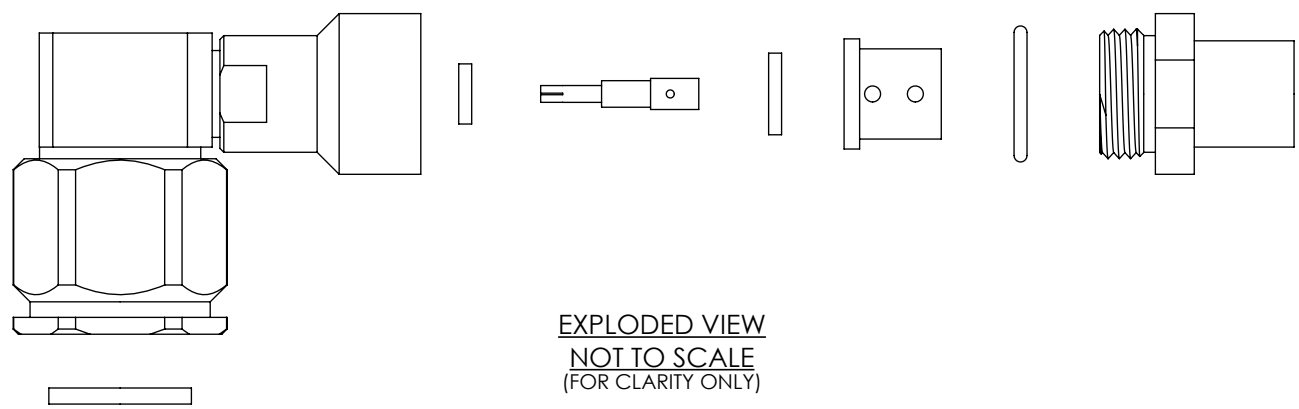
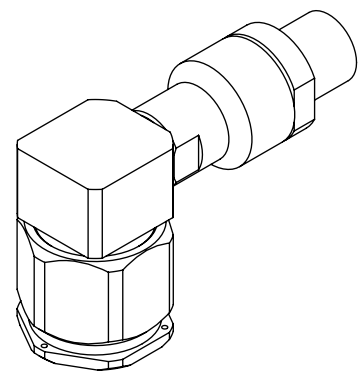
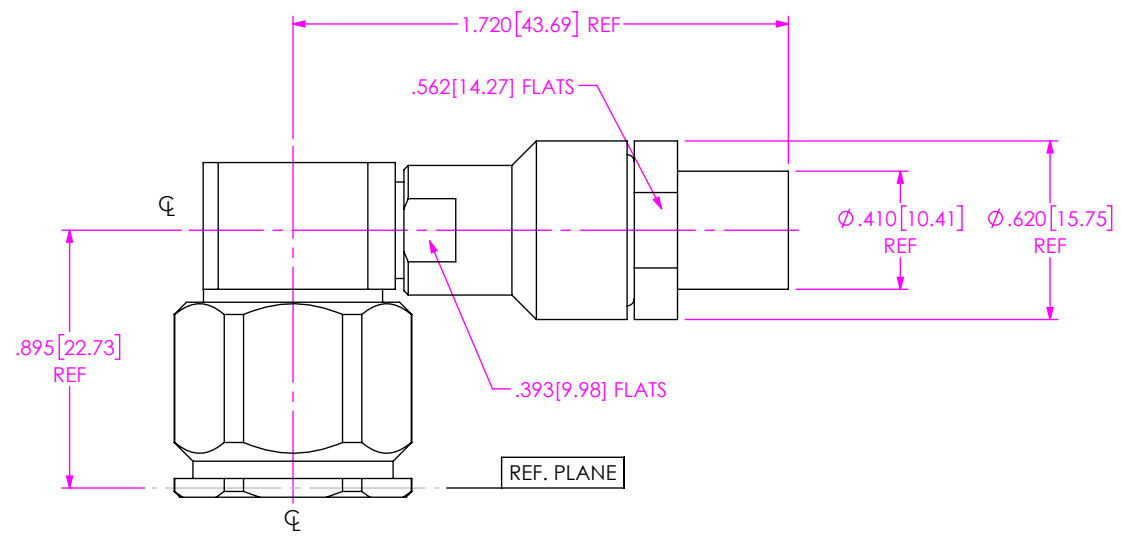

EXPLODED VIEW
NOT TO SCALE
(FOR CLARITY ONLY)

NOTES:
1. MATERIAL:
BODIES, COUPLING & CLAMP NUTS: STAINLESS STEEL.
CONTACT & LOCK RING: BERYLLIUM COPPER.
SOLDER FERRULE: BRASS.
GASKET & O-RING: SILICONE RUBBER.
INSULATORS: TEFLON.
DIELECTRIC BEADS: ULTEM 1000.

2. FINISH:
BODIES, COUPLING & CLAMP NUTS: PASSIVATED.
CONTACT & SOLDER FERRULE: GOLD OVER NICKEL PLATE,
50 µIN MIN GOLD OVER 50 µIN MIN NICKEL.

3. PCI P/N: 3533.

UNLESS OTHERWISE SPECIFIED, DIMENSIONS ARE IN INCHES.
TOLERANCES ARE:
DECIMALS ANGLES
.XX: ±.01 [0.3] 1°
.XXX: ±.005 [0.13]
.XXXX: ±.0005 [0.013]

PROPRIETARY NOTE
THIS DOCUMENT CONTAINS CONFIDENTIAL AND PROPRIETARY INFORMATION AND ALL DESIGN, MANUFACTURING, REPRODUCTION, USE, PATENT RIGHTS AND SALES RIGHTS ARE EXPRESSLY RESERVED BY SAMTEC, INC. THIS DOCUMENT SHALL NOT BE DISCLOSED, IN WHOLE OR PART, TO ANY UNAUTHORIZED PERSON OR ENTITY NOR REPRODUCED, TRANSFERRED OR INCORPORATED IN ANY OTHER PROJECT IN ANY MANNER WITHOUT THE EXPRESS WRITTEN CONSENT OF SAMTEC, INC.



520 PARK EAST BLVD, NEW ALBANY, IN 47150
PHONE: 812-944-6733 FAX: 812-948-5047
e-Mail info@SAMTEC.com code 55322

DO NOT SCALE DRAWING SHEET SCALE: 1.5:1

DESCRIPTION: NTPE RA PLUG, SOLDER CLAMP FOR DF218 DYNAWAVE CABLE

DWG. NO. PRF06-P-C-EP-270A-RS

BY: SAMUEL C 08/20/2020 SHEET 1 OF 3

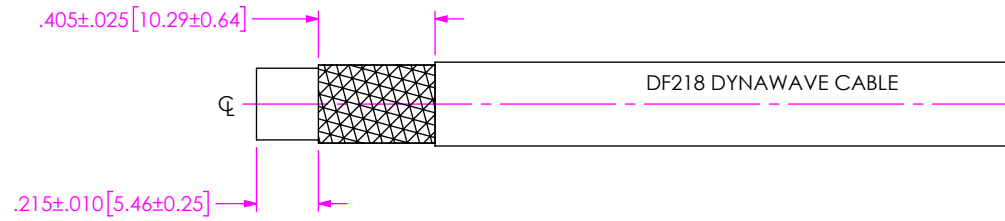

1. TRIM CABLE AS SHOWN.

IN-PROCESS 1

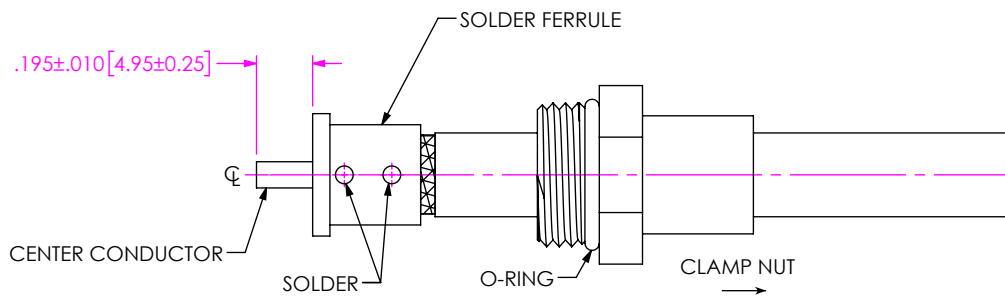

2A. INSERT CABLE INTO SOLDER FERRULE UNTIL BRAIDS SEAT IN FERRULE. THEN SOLDER BOTH CABLE BRAIDS TO FERRULE WHERE SHOWN.

2C. TRIM CABLE DIELECTRIC FLUSH WITH FACE OF FERRULE.

IN-PROCESS 2

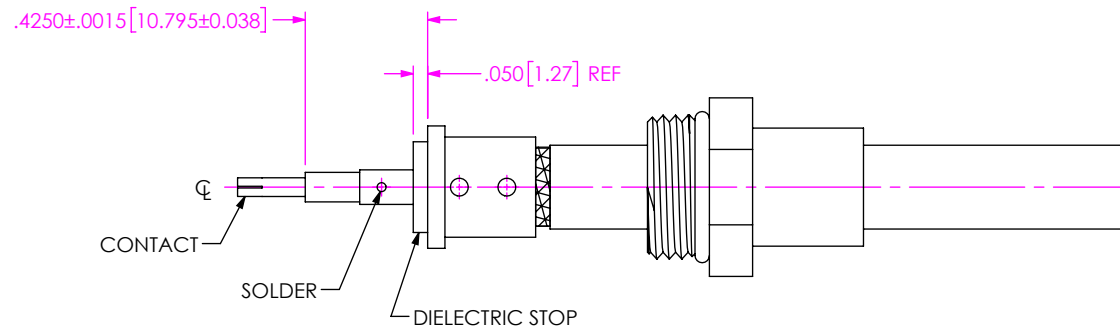

3A. SLIDE DIELECTRIC STOP (∅.315[8.00] OD) ONTO CABLE CENTER CONDUCTOR AGAINST FACE OF SOLDER FERRULE.

3B. SOLDER CONTACT FLUSH TO DIELECTRIC STOP TO DIMENSION SHOWN.

IN-PROCESS 3

<p>PROPRIETARY NOTE</p> <p>THIS DOCUMENT CONTAINS CONFIDENTIAL AND PROPRIETARY INFORMATION AND ALL DESIGN, MANUFACTURING, REPRODUCTION, USE, PATENT RIGHTS AND SALES RIGHTS ARE EXPRESSLY RESERVED BY SAMTEC, INC. THIS DOCUMENT SHALL NOT BE DISCLOSED, IN WHOLE OR PART, TO ANY UNAUTHORIZED PERSON OR ENTITY NOR REPRODUCED, TRANSFERRED OR INCORPORATED IN ANY OTHER PROJECT IN ANY MANNER WITHOUT THE EXPRESS WRITTEN CONSENT OF SAMTEC, INC.</p>	 <p>520 PARK EAST BLVD, NEW ALBANY, IN 47150 PHONE: 812-944-6733 FAX: 812-948-5047 e-Mail info@SAMTEC.com code 55322</p>
<p>DO NOT SCALE DRAWING</p> <p>SHEET SCALE: 1.5:1</p>	<p>DESCRIPTION: NTPC RA PLUG, SOLDER CLAMP FOR DF218 DYNAWAVE CABLE</p> <p>DWG. NO. PRF06-P-C-EP-270A-RS</p> <p>BY: SAMUEL C 08/20/2020 SHEET 2 OF 3</p>

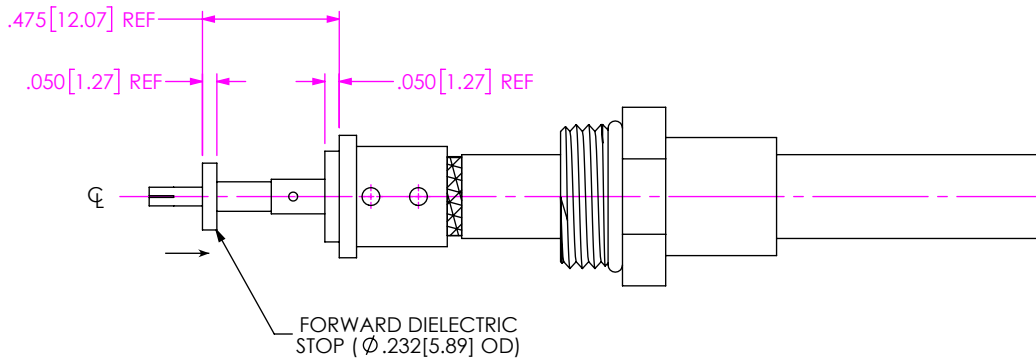

4. SLIDE FORWARD DIELECTRIC STOP ONTO CONTACT. AGAINST SHOULDER AS SHOWN.

IN-PROCESS 4

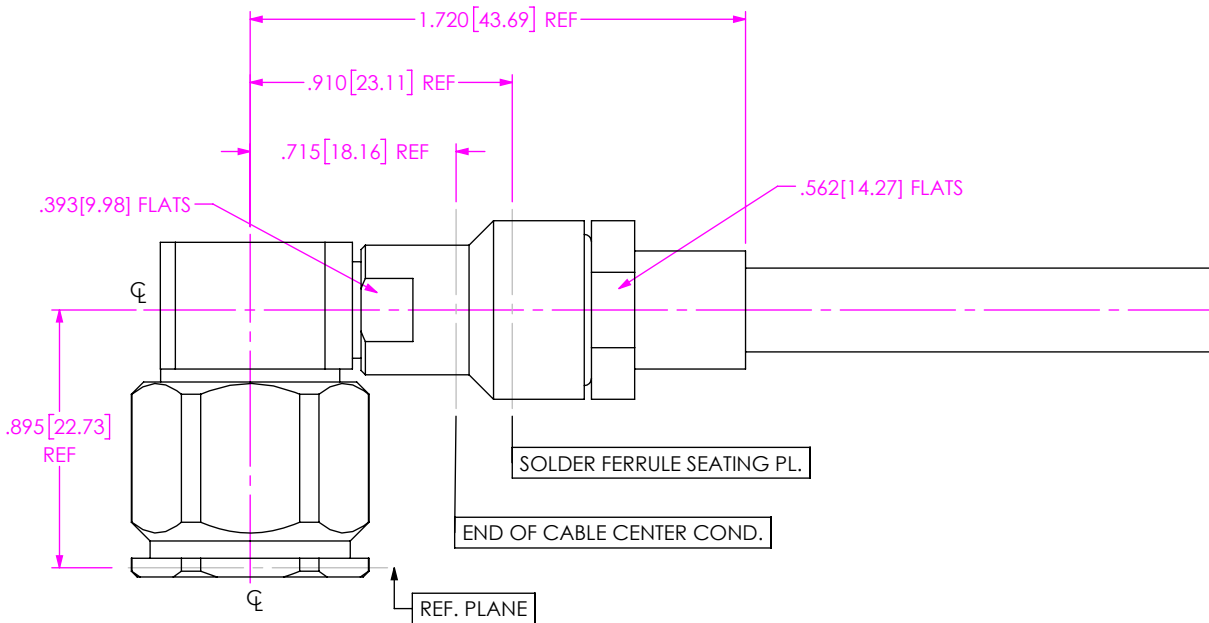

5. INSERT CABLE/CONTACT SUB-ASSEMBLY INTO CONNECTOR UNTIL SEATED AND TIGHTEN CLAMP NUT TO 35-45 IN-LBS.

IN-PROCESS 5

PROPRIETARY NOTE
 THIS DOCUMENT CONTAINS CONFIDENTIAL AND PROPRIETARY INFORMATION AND ALL DESIGN, MANUFACTURING, REPRODUCTION, USE, PATENT RIGHTS AND SALES RIGHTS ARE EXPRESSLY RESERVED BY SAMTEC, INC. THIS DOCUMENT SHALL NOT BE DISCLOSED, IN WHOLE OR PART, TO ANY UNAUTHORIZED PERSON OR ENTITY NOR REPRODUCED, TRANSFERRED OR INCORPORATED IN ANY OTHER PROJECT IN ANY MANNER WITHOUT THE EXPRESS WRITTEN CONSENT OF SAMTEC, INC.



520 PARK EAST BLVD, NEW ALBANY, IN 47150
 PHONE: 812-944-6733 FAX: 812-948-5047
 e-Mail info@SAMTEC.com code 55322

DO NOT SCALE DRAWING

SHEET SCALE: 1.5:1

DESCRIPTION: NTPE RA PLUG, SOLDER CLAMP FOR DF218 DYNAWAVE CABLE

DWG. NO. PRF06-P-C-EP-270A-RS

BY: SAMUEL C 08/20/2020 SHEET 3 OF 3