

National Semiconductor is now part of  
Texas Instruments.

Search <http://www.ti.com/> for the latest technical  
information and details on our current products and services.

# LM5102

## High Voltage Half-Bridge Gate Driver with Programmable Delay

### General Description

The LM5102 High Voltage Gate Driver is designed to drive both the high side and the low side N-Channel MOSFETs in a synchronous buck or a half bridge configuration. The floating high-side driver is capable of working with supply voltages up to 100V. The outputs are independently controlled. The rising edge of each output can be independently delayed with a programming resistor. An integrated high voltage diode is provided to charge the high side gate drive bootstrap capacitor. A robust level shifter operates at high speed while consuming low power and providing clean level transitions from control logic to the high side gate driver. Under-voltage lockout is provided on both the low side and the high side power rails. This device is available in the standard MSOP-10 pin and the LLP-10 pin packages.

### Features

- Drives both a high side and low side N-channel MOSFET
- Independently programmable high and low side rising edge delay

- Bootstrap supply voltage range up to 118V DC
- Fast turn-off propagation delay (25 ns typical)
- Drives 1000 pF loads with 15 ns rise and fall times
- Supply rail under-voltage lockout
- Low power consumption
- Timer can be terminated midway through sequence

### Typical Applications

- Current Fed push-pull power converters
- Half and Full Bridge power converters
- Synchronous Buck converters
- Two switch forward power converters
- Forward with Active Clamp converters

### Package

- MSOP-10
- LLP-10 (4 mm x 4 mm)

### Simplified Block Diagram

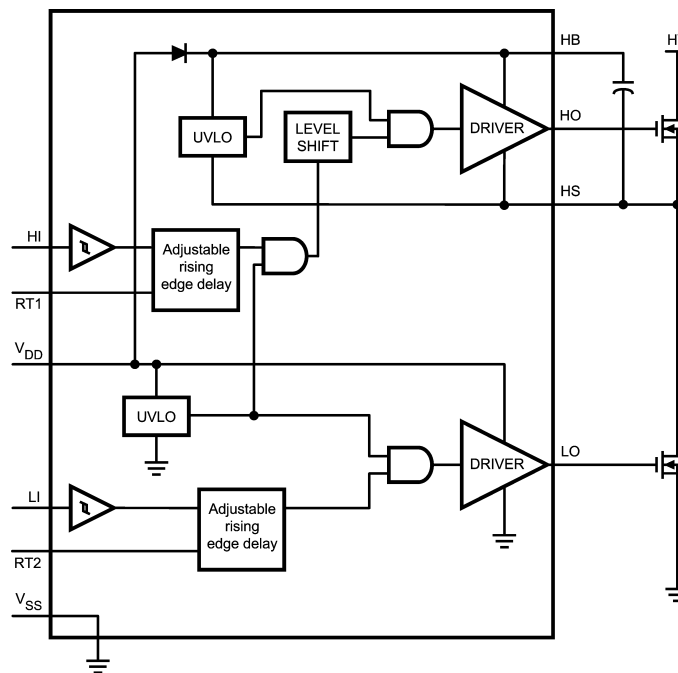

FIGURE 1.

LM5102 High Voltage Half-Bridge Gate Driver with Programmable Delay

## Connection Diagram

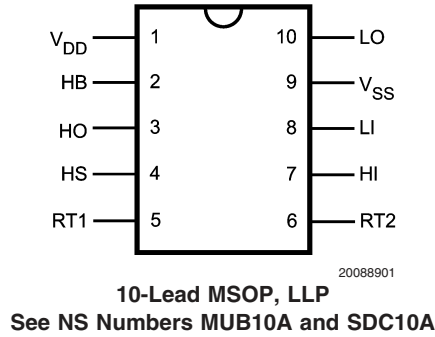

FIGURE 2.

## Ordering Information

Ordering Number	Package Type	NSC Package Drawing	Supplied As
LM5102MM	MSOP-10	MUB10A	1000 shipped as Tape & Reel
LM5102MMX	MSOP-10	MUB10A	3500 shipped as Tape & Reel
LM5102SD	LLP-10	SDC10A	1000 shipped as Tape & Reel
LM5102SDX	LLP-10	SDC10A	4500 shipped as Tape & Reel

## Pin Descriptions

Pin		Name	Description	Application Information
MSOP-10	LLP-10			
1	1	V <sub>DD</sub>	Positive gate drive supply	Locally decouple to V <sub>SS</sub> using low ESR/ESL capacitor, located as close to IC as possible.
2	2	HB	High side gate driver bootstrap rail	Connect the positive terminal of bootstrap capacitor to the HB pin and connect negative terminal of bootstrap capacitor to HS. The Bootstrap capacitor should be placed as close to IC as possible.
3	3	HO	High side gate driver output	Connect to gate of high side MOSFET with short low inductance path.
4	4	HS	High side MOSFET source connection	Connect bootstrap capacitor negative terminal and source of high side MOSFET.
5	5	RT1	High side output edge delay programming	Resistor from RT1 to ground programs the leading edge delay of the high side gate driver. The resistor should be placed close to the IC to minimize noise coupling from adjacent traces.
6	6	RT2	Low side output edge delay programming	Resistor from RT2 to ground programs the leading edge delay of the low side gate driver. The resistor should be placed close to the IC to minimize noise coupling from adjacent traces.
7	7	HI	High side driver control input	TTL compatible thresholds. Unused inputs should be tied to ground and not left open.
8	8	LI	Low side driver control input	TTL compatible thresholds. Unused inputs should be tied to ground and not left open.
9	9	V <sub>SS</sub>	Ground return	All signals are referenced to this ground.
10	10	LO	Low side gate driver output	Connect to the gate of the low side MOSFET with a short low inductance path.

Note: For LLP-10 package, it is recommended that the exposed pad on the bottom of the LM5100 / LM5101 be soldered to ground plane on the PC board, and the ground plane should extend out from beneath the IC to help dissipate the heat.

**Absolute Maximum Ratings** (Note 1)

If Military/Aerospace specified devices are required, please contact the National Semiconductor Sales Office/Distributors for availability and specifications.

$V_{DD}$ to $V_{SS}$	-0.3V to +18V
$V_{HB}$ to $V_{HS}$	-0.3V to +18V
LI or HI Inputs to $V_{SS}$	-0.3V to $V_{DD} + 0.3V$
LO Output	-0.3V to $V_{DD} + 0.3V$
HO Output	$V_{HS} - 0.3V$ to $V_{HB} + 0.3V$
$V_{HS}$ to $V_{SS}$	-1V to +100V
$V_{HB}$ to $V_{SS}$	118V
RT1 & RT2 to $V_{SS}$	-0.3V to 5V
Junction Temperature	+150°C

Storage Temperature Range	-55°C to +150°C
ESD Rating HBM (Note 2)	2 kV

**Recommended Operating Conditions**

$V_{DD}$	+9V to +14V
HS	-1V to 100V
HB	$V_{HS} + 8V$ to $V_{HS} + 14V$
HS Slew Rate	<50V/ns
Junction Temperature	-40°C to +125°C

**Electrical Characteristics** Specifications in standard typeface are for  $T_J = +25^\circ\text{C}$ , and those in **boldface type** apply over the full **operating junction temperature range**. Unless otherwise specified,  $V_{DD} = V_{HB} = 12V$ ,  $V_{SS} = V_{HS} = 0V$ ,  $RT1 = RT2 = 100k\Omega$ . No Load on LO or HO.

Symbol	Parameter	Conditions	Min	Typ	Max	Units
<b>SUPPLY CURRENTS</b>						
$I_{DD}$	$V_{DD}$ Quiescent Current	LI = HI = 0V		0.4	<b>0.6</b>	mA
$I_{DDO}$	$V_{DD}$ Operating Current	f = 500 kHz		1.5	<b>3</b>	mA
$I_{HB}$	Total HB Quiescent Current	LI = HI = 0V		0.06	<b>0.2</b>	mA
$I_{HBO}$	Total HB Operating Current	f = 500 kHz		1.3	<b>3</b>	mA
$I_{HBS}$	HB to $V_{SS}$ Current, Quiescent	$V_{HS} = V_{HB} = 100V$		0.05	<b>10</b>	$\mu\text{A}$
$I_{HBSO}$	HB to $V_{SS}$ Current, Operating	f = 500 kHz		0.08		mA
<b>INPUT PINS</b>						
$V_{IL}$	Low Level Input Voltage Threshold		<b>0.8</b>	1.8		V
$V_{IH}$	High Level Input Voltage Threshold			1.8	<b>2.2</b>	V
$R_I$	Input Pulldown Resistance		<b>100</b>	200	<b>500</b>	k $\Omega$
<b>TIME DELAY CONTROLS</b>						
$V_{RT}$	Nominal Voltage at RT1, RT2		<b>2.7</b>	3	<b>3.3</b>	V
$I_{RT}$	RT Pin Current Limit	RT1 = RT2 = 0V	<b>0.75</b>	1.5	<b>2.25</b>	mA
$V_{th}$	Timer Termination Threshold			1.8		V
$T_{DL1}, T_{DH1}$	Rising edge turn-on delay, RT = 10 k $\Omega$		<b>75</b>	105	<b>150</b>	ns
$T_{DL2}, T_{DH2}$	Rising edge turn-on delay, RT = 100 k $\Omega$		<b>530</b>	630	<b>750</b>	ns
<b>UNDER VOLTAGE PROTECTION</b>						
$V_{DDR}$	$V_{DD}$ Rising Threshold		<b>6.0</b>	6.9	<b>7.4</b>	V
$V_{DDH}$	$V_{DD}$ Threshold Hysteresis			0.5		V
$V_{HBR}$	HB Rising Threshold		<b>5.7</b>	6.6	<b>7.1</b>	V
$V_{HBH}$	HB Threshold Hysteresis			0.4		V
<b>BOOT STRAP DIODE</b>						
$V_{DL}$	Low-Current Forward Voltage	$I_{VDD-HB} = 100 \mu\text{A}$		0.60	<b>0.9</b>	V
$V_{DH}$	High-Current Forward Voltage	$I_{VDD-HB} = 100 \text{mA}$		0.85	<b>1.1</b>	V
$R_D$	Dynamic Resistance	$I_{VDD-HB} = 100 \text{mA}$		0.8	<b>1.5</b>	$\Omega$
<b>LO GATE DRIVER</b>						
$V_{OLL}$	Low-Level Output Voltage	$I_{LO} = 100 \text{mA}$		0.25	<b>0.4</b>	V
$V_{OHL}$	High-Level Output Voltage	$I_{LO} = -100 \text{mA}$ , $V_{OHL} = V_{DD} - V_{LO}$		0.35	<b>0.55</b>	V
$I_{OHL}$	Peak Pullup Current	$V_{LO} = 0V$		1.6		A
$I_{OLL}$	Peak Pulldown Current	$V_{LO} = 12V$		1.8		A
<b>HO GATE DRIVER</b>						
$V_{OLH}$	Low-Level Output Voltage	$I_{HO} = 100 \text{mA}$		0.25	<b>0.4</b>	V

**Electrical Characteristics** Specifications in standard typeface are for  $T_J = +25^\circ\text{C}$ , and those in **boldface type** apply over the full **operating junction temperature range**. Unless otherwise specified,  $V_{DD} = V_{HB} = 12\text{V}$ ,  $V_{SS} = V_{HS} = 0\text{V}$ ,  $RT1 = RT2 = 100\text{k}\Omega$ . No Load on LO or HO. (Continued)

Symbol	Parameter	Conditions	Min	Typ	Max	Units
$V_{OHH}$	High-Level Output Voltage	$I_{HO} = -100\text{ mA}$ , $V_{OHH} = V_{HB} - V_{HO}$		0.35	<b>0.55</b>	V
$I_{OHH}$	Peak Pullup Current	$V_{HO} = 0\text{V}$		1.6		A
$I_{OLH}$	Peak Pulldown Current	$V_{HO} = 12\text{V}$		1.8		A
<b>THERMAL RESISTANCE</b>						
$\theta_{JA}$	Junction to Ambient	MSOP		200		$^\circ\text{C/W}$
		LLP-10 (Note 3)		40		

**Switching Characteristics** Specifications in standard typeface are for  $T_J = +25^\circ\text{C}$ , and those in **boldface type** apply over the full **operating junction temperature range**. Unless otherwise specified,  $V_{DD} = V_{HB} = 12\text{V}$ ,  $V_{SS} = V_{HS} = 0\text{V}$ , No Load on LO or HO.

Symbol	Parameter	Conditions	Min	Typ	Max	Units
$t_{LPHL}$	Lower Turn-Off Propagation Delay LM5102 (LI Falling to LO Falling)			27	<b>56</b>	ns
$t_{HPHL}$	Upper Turn-Off Propagation Delay LM5102 (HI Falling to HO Falling)			27	<b>56</b>	ns
$t_{RC}, t_{FC}$	Either Output Rise/Fall Time	$C_L = 1000\text{ pF}$		15		ns
$t_R, t_F$	Either Output Rise/Fall Time (3V to 9V)	$C_L = 0.1\text{ }\mu\text{F}$		0.6		$\mu\text{s}$
$t_{BS}$	Bootstrap Diode Turn-Off Time	$I_F = 20\text{ mA}$ , $I_R = 200\text{ mA}$		50		ns

**Note 1:** Absolute Maximum Ratings indicate limits beyond which damage to the component may occur. Operating Ratings are conditions under which operation of the device is guaranteed. Operating Ratings do not imply guaranteed performance limits. For guaranteed performance limits and associated test conditions, see the Electrical Characteristics tables.

**Note 2:** The human body model is a 100 pF capacitor discharged through a 1.5k $\Omega$  resistor into each pin. 2 kV for all pins except Pin 2, Pin 3 and Pin 4 which are rated at 500V.

**Note 3:** 4 layer board with Cu finished thickness 1.5/1/1/1.5 oz. Maximum die size used. 5x body length of Cu trace on PCB top. 50 x 50mm ground and power planes embedded in PCB. See Application Note AN-1187.

**Note 4:** Min and Max limits are 100% production tested at 25 $^\circ\text{C}$ . Limits over the operating temperature range are guaranteed through correlation using Statistical Quality Control (SQC) methods. Limits are used to calculate National's Average Outgoing Quality Level (AOQL).

**Note 5:** The  $\theta_{JA}$  is not a given constant for the package and depends on the printed circuit board design and the operating environment.

# Typical Performance Characteristics

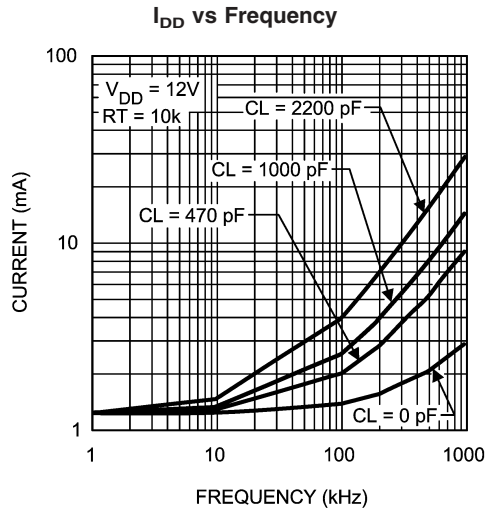

20088910

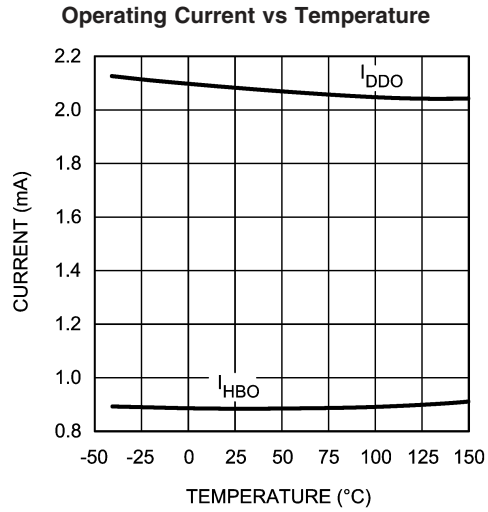

20088911

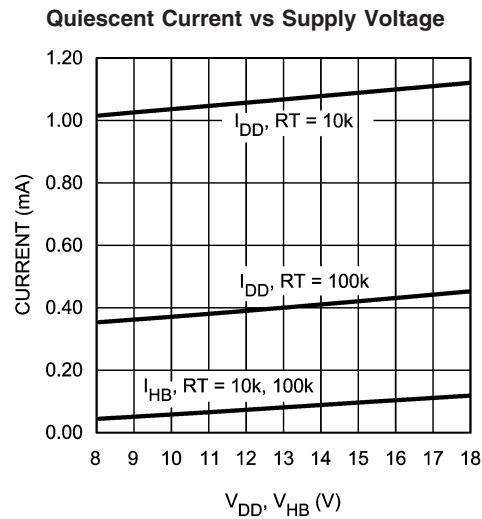

20088912

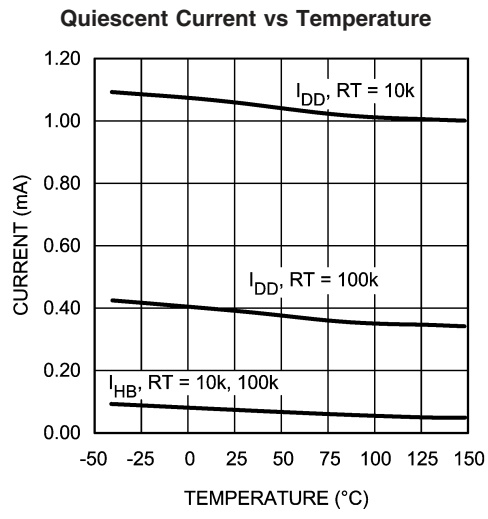

20088913

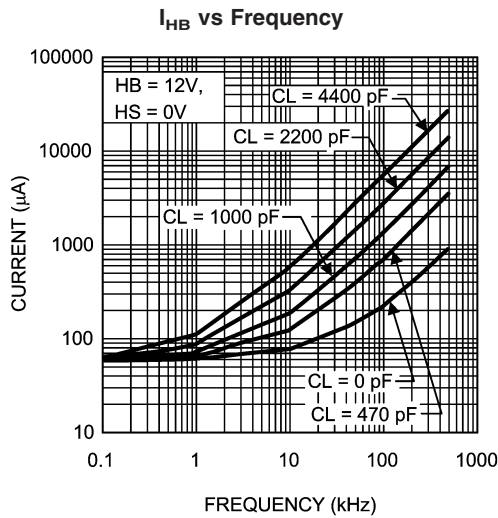

20088916

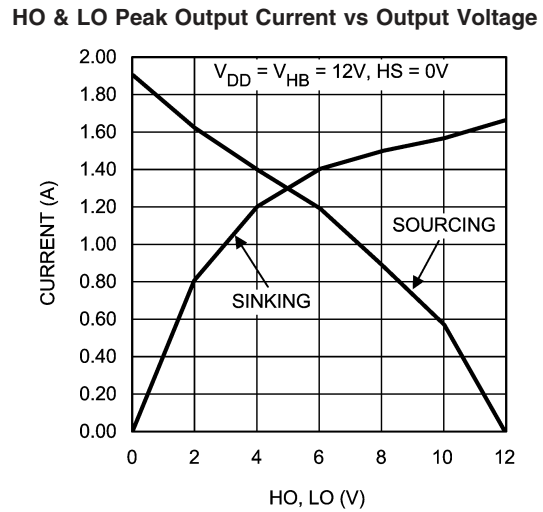

20088917

Typical Performance Characteristics (Continued)

Diode Forward Voltage

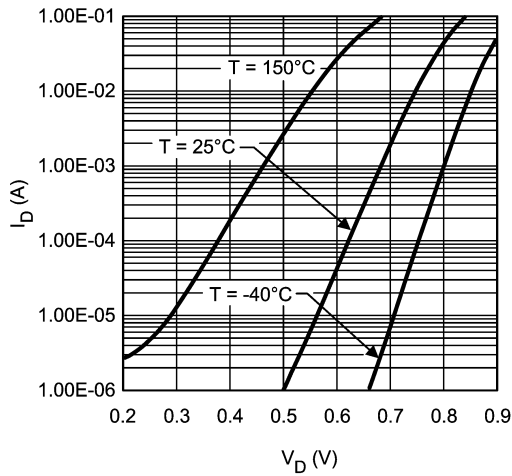

20088915

Undervoltage Threshold Hysteresis vs Temperature

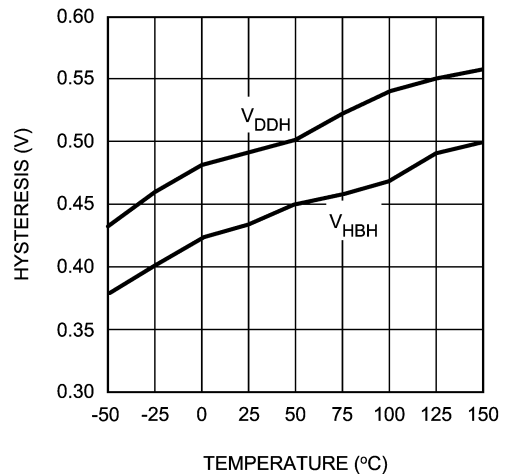

20088918

Undervoltage Rising Threshold vs Temperature

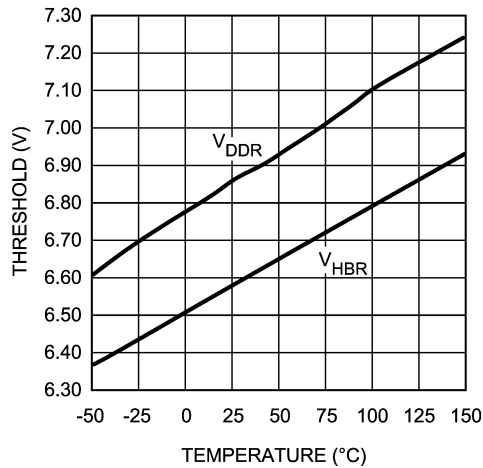

20088919

LO & HO Gate Drive—High Level Output Voltage vs Temperature

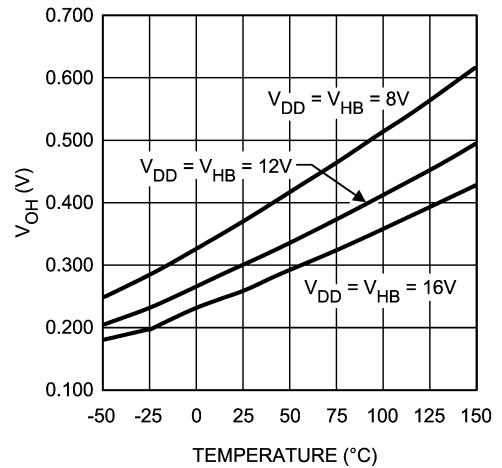

20088920

LO & HO Gate Drive—Low Level Output Voltage vs Temperature

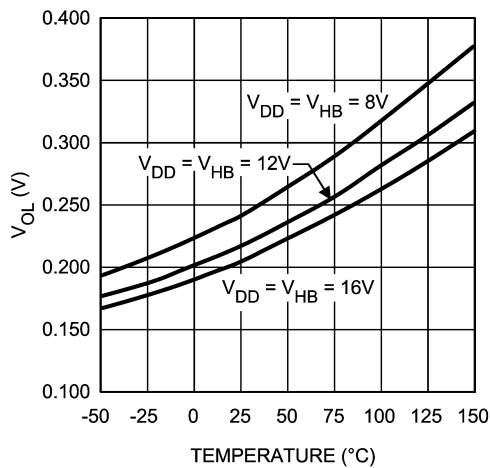

20088921

Turn Off Propagation Delay vs Temperature

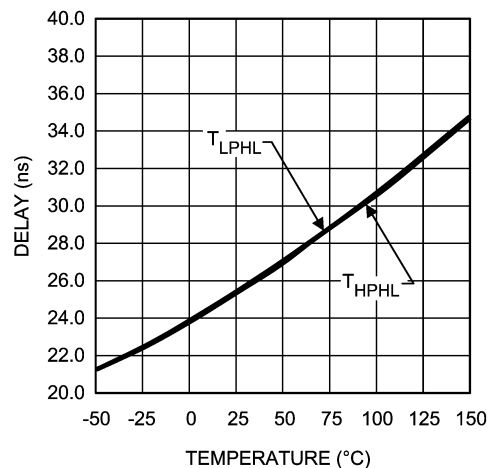

20088922

# Typical Performance Characteristics (Continued)

Turn On Delay vs RT Resistor Value

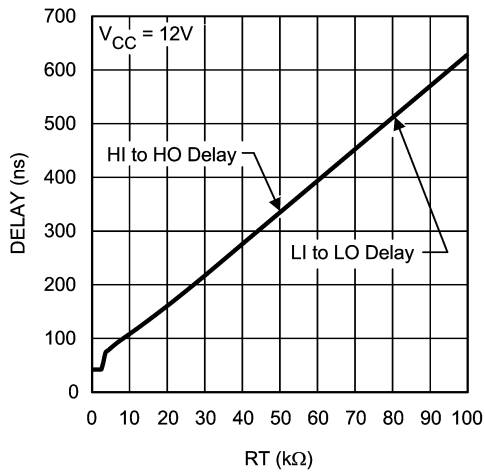

20088914

Turn On Delay vs Temperature (RT = 10k)

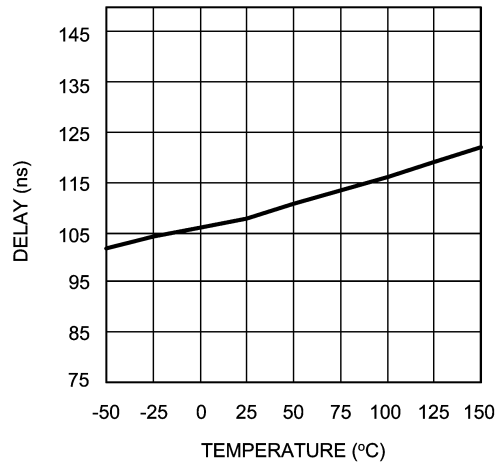

20088926

Turn On Delay vs Temperature (RT = 100k)

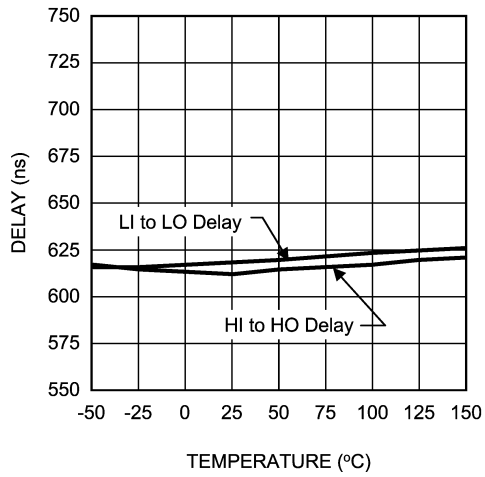

20088927



## LM5102 Waveforms

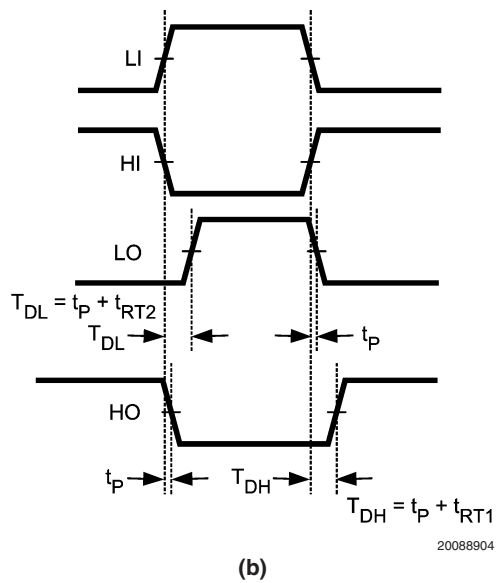
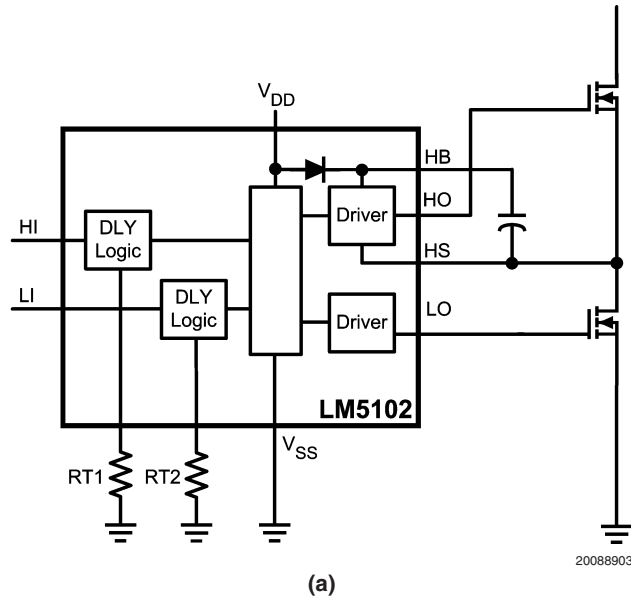

FIGURE 3. Application Timing Waveforms

## Operational Notes

The LM5102 offers a unique flexibility with independently programmable delay of the rising edge for both high and low side driver outputs independently. The delays are set with resistors at the RT1 and RT2 pins, and can be adjusted from 100 ns to 600 ns. This feature reduces component count, board space and cost compared to discrete solutions for adjusting driver dead time. The wide delay programming range provides the flexibility to optimize drive signal timing for a wide range of MOSFETs and applications.

The RT pins are biased at 3V and current limited to 1 mA maximum programming current. The time delay generator will accommodate resistor values from 5k to 100k with turn-on delay times that are proportional to the RT resis-

tance. In addition, each RT pin is monitored by a comparator that will bypass the turn-on delay if the RT pin is pulled below the timer elimination threshold (1.8V typical). Grounding the RT pins programs the LM5102 to drive both outputs with minimum turn-on delay.

## STARTUP AND UVLO

Both top and bottom drivers include under-voltage lockout (UVLO) protection circuitry which monitors the supply voltage ( $V_{DD}$ ) and bootstrap capacitor voltage ( $V_{HB} - V_{HS}$ ) independently. The UVLO circuit inhibits each driver until sufficient supply voltage is available to turn-on the external MOSFETs, and the built-in hysteresis prevents chattering during supply voltage transitions. When the supply voltage is applied to  $V_{DD}$  pin of LM5102, the top and bottom gates are

## Operational Notes (Continued)

held low until  $V_{DD}$  exceeds UVLO threshold, typically about 6.9V. Any UVLO condition on the bootstrap capacitor will disable only the high side output (HO).

### LAYOUT CONSIDERATIONS

The optimum performance of high and low side gate drivers cannot be achieved without taking due considerations during circuit board layout. Following points are emphasized.

1. A low ESR/ESL capacitor must be connected close to the IC, and between  $V_{DD}$  and  $V_{SS}$  pins and between HB and HS pins to support high peak currents being drawn from  $V_{DD}$  during turn-on of the external MOSFET.
2. To prevent large voltage transients at the drain of the top MOSFET, a low ESR electrolytic capacitor must be connected between MOSFET drain and ground ( $V_{SS}$ ).
3. In order to avoid large negative transients on the switch node (HS) pin, the parasitic inductances in the source of top MOSFET and in the drain of the bottom MOSFET (synchronous rectifier) must be minimized.
4. Grounding considerations:
  - a) The first priority in designing grounding connections is to confine the high peak currents from charging and discharging the MOSFET gate in a minimal physical area. This will decrease the loop inductance and minimize noise issues on the gate terminal of the MOSFET. The MOSFETs should be placed as close as possible to the gate driver.
  - b) The second high current path includes the bootstrap capacitor, the bootstrap diode, the local ground referenced bypass capacitor and low side MOSFET body diode. The bootstrap capacitor is recharged on the cycle-by-cycle basis through the bootstrap diode from the ground referenced  $V_{DD}$  bypass capacitor. The recharging occurs in a short time interval and involves high peak current. Minimizing this loop length and area on the circuit board is important to ensure reliable operation.
5. The resistors on the RT1 and RT2 timer pins must be placed very close to the IC and separated from high current paths to avoid noise coupling to the time delay generator which could disrupt timer operation.

### POWER DISSIPATION CONSIDERATIONS

The total IC power dissipation is the sum of the gate driver losses and the bootstrap diode losses. The gate driver losses are related to the switching frequency ( $f$ ), output load capacitance on LO and HO ( $C_L$ ), and supply voltage ( $V_{DD}$ ) and can be roughly calculated as:

$$P_{DGATES} = 2 \cdot f \cdot C_L \cdot V_{DD}^2$$

There are some additional losses in the gate drivers due to the internal CMOS stages used to buffer the LO and HO outputs. The following plot shows the measured gate driver power dissipation versus frequency and load capacitance. At higher frequencies and load capacitance values, the power dissipation is dominated by the power losses driving the output loads and agrees well with the above equation. This plot can be used to approximate the power losses due to the gate drivers.

**Gate Driver Power Dissipation (LO + HO)**  
 $V_{CC} = 12V$ , Neglecting Diode Losses

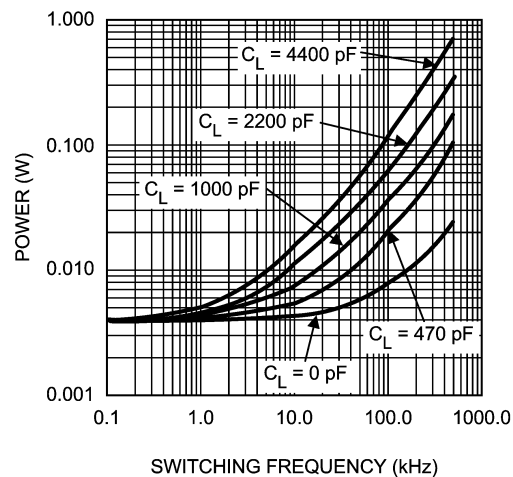

20088905

The bootstrap diode power loss is the sum of the forward bias power loss that occurs while charging the bootstrap capacitor and the reverse bias power loss that occurs during reverse recovery. Since each of these events happens once per cycle, the diode power loss is proportional to frequency. Larger capacitive loads require more current to recharge the bootstrap capacitor resulting in more losses. Higher input voltages ( $V_{IN}$ ) to the half bridge result in higher reverse recovery losses. The following plot was generated based on calculations and lab measurements of the diode recovery time and current under several operating conditions. This can be useful for approximating the diode power dissipation.

## Operational Notes (Continued)

### Diode Power Dissipation $V_{IN} = 80V$

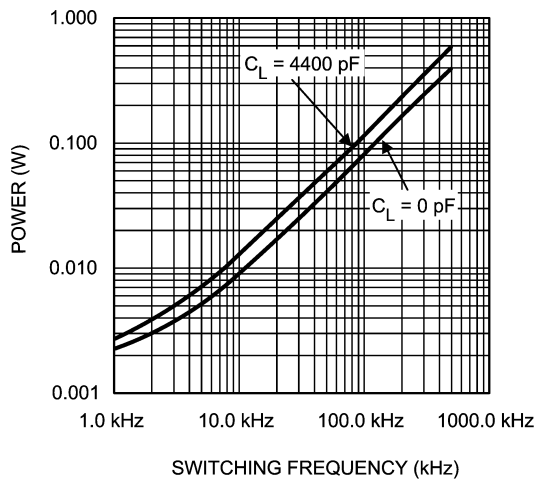

20088906

### Diode Power Dissipation $V_{IN} = 40V$

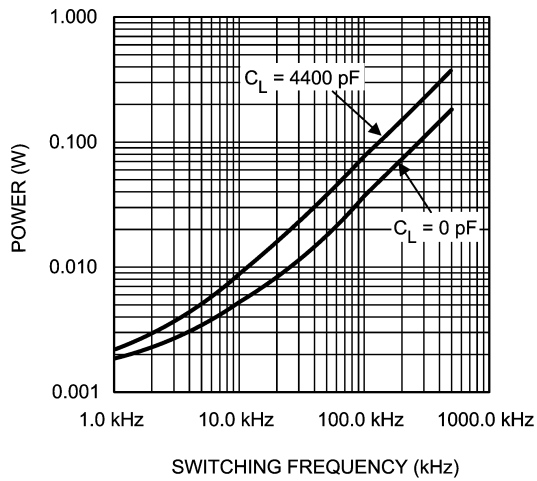

20088907

The total IC power dissipation can be estimated from the above plots by summing the gate drive losses with the bootstrap diode losses for the intended application. Because the diode losses can be significant, an external diode placed in parallel with the internal bootstrap diode (refer to *Figure 4*) and can be helpful in removing power from the IC. For this to be effective, the external diode must be placed close to the IC to minimize series inductance and have a significantly lower forward voltage drop than the internal diode.

**Operational Notes** (Continued)

**LM5102 Driving MOSFETs Connected in Half-Bridge Configuration**

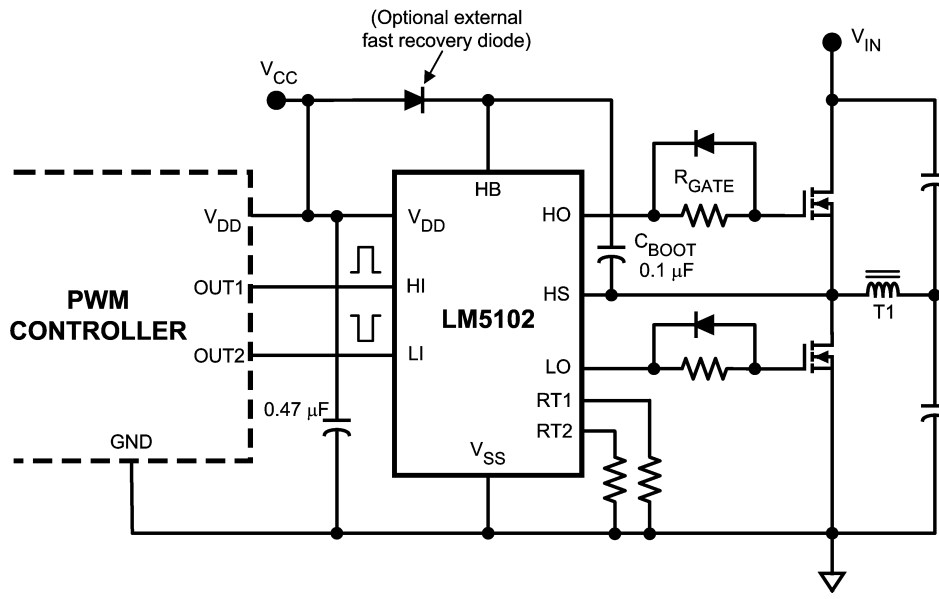

20088908

FIGURE 4.

**Physical Dimensions** inches (millimeters) unless otherwise noted

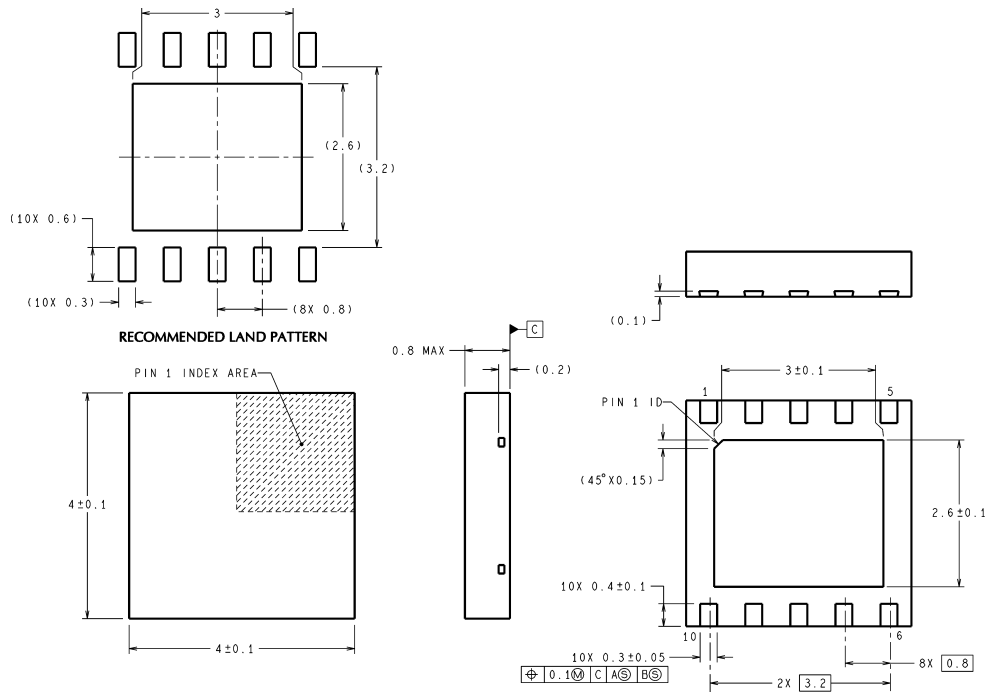

DIMENSIONS ARE IN MILLIMETERS

SDC10A (Rev A)

Notes: Unless otherwise specified

1. Standard lead finish to be 200 microinches/5.00 micrometers minimum tin/lead (solder) on copper.
2. Pin 1 identification to have half of full circle option.
3. No JEDEC registration as of Feb. 2000.

**LLP-10 Outline Drawing  
NS Package Number SDC10A**

**Physical Dimensions** inches (millimeters) unless otherwise noted (Continued)

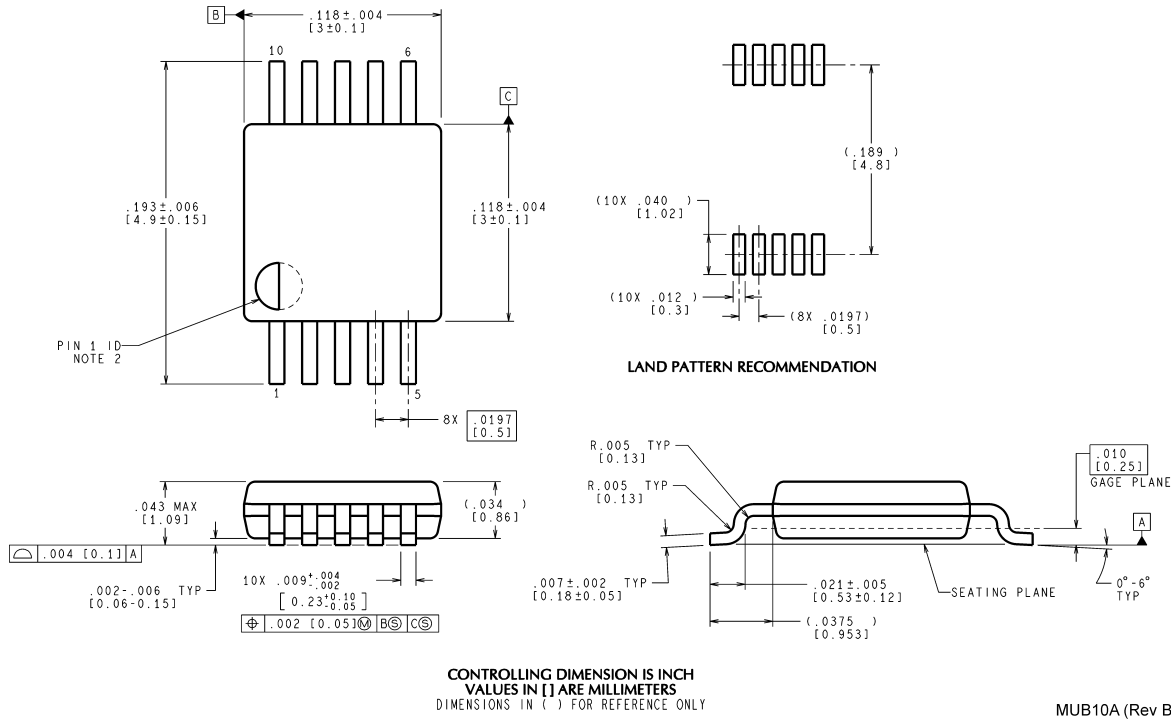

Notes: Unless otherwise specified

1. For solder thickness and composition, see "Solder Information" in the packaging section of the National Semiconductor web page ([www.national.com](http://www.national.com)).
2. Maximum allowable metal burr on lead tips at the package edges is 76 microns.
3. No JEDEC registration as of May 2003.

**MSOP-10 Outline Drawing  
NS Package Number MUB10A**

**LIFE SUPPORT POLICY**

NATIONAL'S PRODUCTS ARE NOT AUTHORIZED FOR USE AS CRITICAL COMPONENTS IN LIFE SUPPORT DEVICES OR SYSTEMS WITHOUT THE EXPRESS WRITTEN APPROVAL OF THE PRESIDENT AND GENERAL COUNSEL OF NATIONAL SEMICONDUCTOR CORPORATION. As used herein:

1. Life support devices or systems are devices or systems which, (a) are intended for surgical implant into the body, or (b) support or sustain life, and whose failure to perform when properly used in accordance with instructions for use provided in the labeling, can be reasonably expected to result in a significant injury to the user.
2. A critical component is any component of a life support device or system whose failure to perform can be reasonably expected to cause the failure of the life support device or system, or to affect its safety or effectiveness.

**BANNED SUBSTANCE COMPLIANCE**

National Semiconductor certifies that the products and packing materials meet the provisions of the Customer Products Stewardship Specification (CSP-9-111C2) and the Banned Substances and Materials of Interest Specification (CSP-9-111S2) and contain no "Banned Substances" as defined in CSP-9-111S2.



**National Semiconductor**  
Americas Customer Support Center  
Email: [new.feedback@nsc.com](mailto:new.feedback@nsc.com)  
Tel: 1-800-272-9959

**National Semiconductor**  
Europe Customer Support Center  
Fax: +49 (0) 180-530 85 86  
Email: [europa.support@nsc.com](mailto:europa.support@nsc.com)  
Deutsch Tel: +49 (0) 69 9508 6208  
English Tel: +44 (0) 870 24 0 2171  
Français Tel: +33 (0) 1 41 91 8790

**National Semiconductor**  
Asia Pacific Customer Support Center  
Email: [ap.support@nsc.com](mailto:ap.support@nsc.com)

**National Semiconductor**  
Japan Customer Support Center  
Fax: 81-3-5639-7507  
Email: [jpn.feedback@nsc.com](mailto:jpn.feedback@nsc.com)  
Tel: 81-3-5639-7560

[www.national.com](http://www.national.com)