

**12 & 14 BIT
 MULTIPLYING DACs**

FEATURES

- Accuracy/resolution to 14-bits
- 2 and 4-quadrant multiplication
- -55°C to $+125^{\circ}\text{C}$ operation
- Ladders and feedback resistors trimmed to $\pm 5\%$ absolute
- Low power
- Single power supply

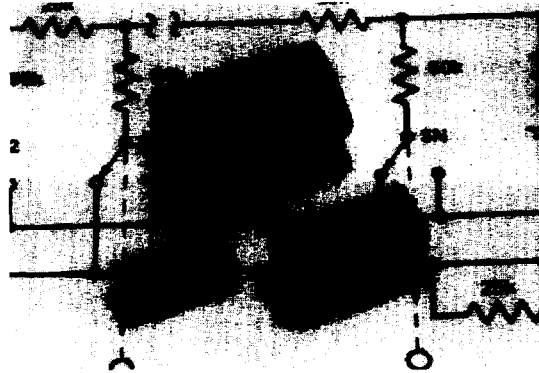

DESCRIPTION

The DAC331 Series includes 12 and 14-bit multiplying digital-to-analog (DAC) converters. Linearity error of $\pm 1/2$ LSB maximum is standard for all models. All models are capable of both 2-quadrant (unipolar) and 4-quadrant (bipolar) multiplication and 2-quadrant division. Models are available in commercial/industrial grade ("C" versions) for 0 to $+70^{\circ}\text{C}$ operation. "B" versions are processed to the requirements of MIL-STD-883 Rev. C, Level B and are specified for use over a wide, -55°C to $+125^{\circ}\text{C}$, temperature range.

Ultra-stable R/2R thin-film resistor ladder networks are trimmed to 25K/50K Ω absolute. Each DAC331

includes a 25K Ω feedback resistor (for use with external op amp) that closely tracks the R/2R ladder. Linearity tempco is a low ± 2 ppm/ $^{\circ}\text{C}$ FSR. Gain tempcos are for 12-and 14-bit models.

Each DAC331 Series converter operates from a single, +5V power supply. Power consumed is less than 30 mW. All models are TTL/DTL and CMOS compatible.

Uses for DAC331 Series converters include digital attenuation of AC and DC voltages, digital gain control, and stroke generators for CRT graphics displays. DAC331's low power is well suited to battery powered equipment applications.

7

FUNCTIONAL DIAGRAM

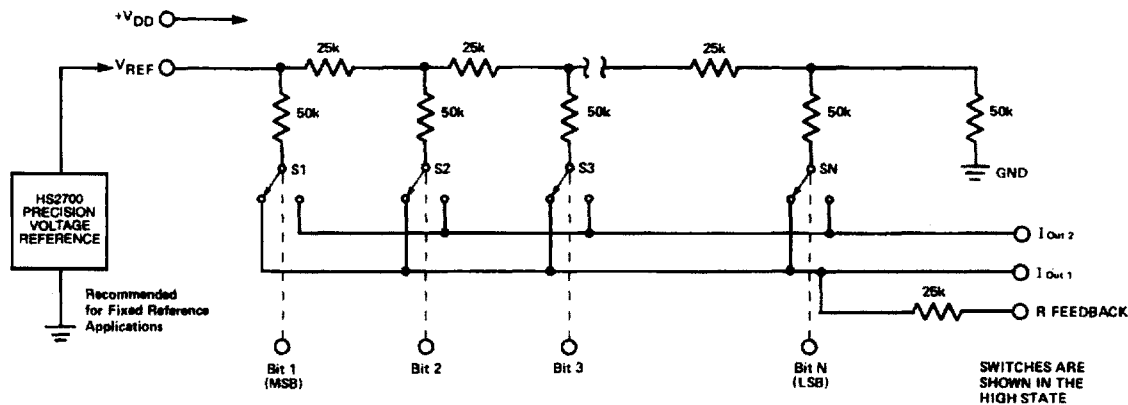

SPECIFICATIONS

(Typical @ +25°C unless otherwise noted; Using V_{DD} nominal power supply, V_{REF} = +10V)

SERIES	DAC331
TYPE	Multiplying, Current Output
DIGITAL INPUT	
Resolution:	
-12 models	12 Bits
-14 models	14 Bits
2-Quad, Unipolar Coding	Binary
4-Quad, Bipolar Coding	Offset Binary
Logic Compatibility	DTL, TTL, 5V CMOS
Logic Thresholds ¹	V _{IH} =3.0V (min), V _{IL} =1.0V (max)
Input Leakage Current	±1μA (max) @ 0V < V _{IN} < V _{DD}
REFERENCE INPUT	
Voltage Range	±25V (max)
Input Impedance	25KΩ ± 1% (nom) ²
ANALOG OUTPUT	
Gain Accuracy ³	40μA/V ± 0.1% F.S.R., typ; ±1.0% F.S.R., max
Offset ⁴	50μV (max)
Small Signal 3 dB Bandwidth	600 kHz (min)
Output Capacitance	
C _{out1}	100pF (max) all inputs high
C _{out2}	65pF (max) all inputs high
C _{out1}	65pF (max) all inputs low
C _{out2}	100pF (max) all inputs low
STATIC PERFORMANCE	
Integral Linearity (all models)	±½ LSB (max)
Differential Linearity (all models)	±½ LSB, typ; ±1 LSB, max
DYNAMIC PERFORMANCE	
Major Code Transition Settling to ± 0.05%	
12 and 14 Bit models	3.0μS (max)
Reference Feedthrough Error (V _{REF} = 20V _{pp} @ 10 kHz)	10mV _{pp}
STABILITY⁴ (Over Specified Temp. Range)	
Scale Factor ⁵	
12 and 14 Bit models	±3ppm/°C F.S.R. (max)
Linearity (all models)	±3ppm/°C F.S.R. (max)
Differential Linearity (all models)	±2ppm/°C F.S.R. (max)
POWER SUPPLY (V_{DD})⁶	
Voltage Range @ Current	+5V (nom); +4.75V to +10V @ < 1mA
Rejection Ratio Total Dissipation (inputs at GND)	0.005%/ % (max) 30mW (max)
TEMPERATURE RANGE	
Specified:	
-C Versions	0°C to +70°C
-B Versions	-55°C to +125°C
Operating (all models)	-55°C to +125°C
Storage (all models)	-65°C to +150°C
MECHANICAL	
Case Style	metal

CAUTION: ESD (Electro-Static Discharge) sensitive device. Permanent damage may occur when unconnected devices are subjected to high energy electrostatic fields. Unless otherwise noted, the voltage at any digital input should never exceed the supply voltage by more than 0.5 volts or go below -0.5 volts. Power supply should come up before, or at the same time, as the digital input supply.

18- & 24-Pin Case Envelope Dimensions

12-Bit models

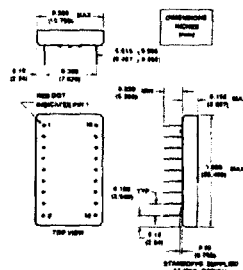

PIN	FUNCTION	PIN	FUNCTION
1	OUT 1	18	R FEEDBACK
2	OUT 2	17	VREF
3	GND	16	-VDD
4	Bit 1 (MSB)	15	Bit 12 (LSB)
5	Bit 2	14	Bit 11
6	Bit 4	13	Bit 10
7	Bit 5	12	Bit 9
8	Bit 6	11	Bit 8
9	Bit 7	10	Bit 7

14-Bit models

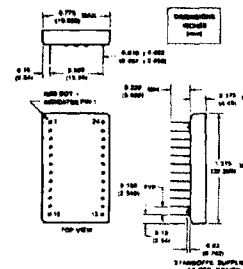

PIN	FUNCTION	PIN	FUNCTION
1	R FEEDBACK	24	VREF
2	OUT 2	23	-VDD
3	OUT 1	22	BIT 9
4	N.C.	21	BIT 8
5	BIT 1 (MSB)	20	BIT 7
6	BIT 2	19	BIT 6
7	BIT 3	18	BIT 5
8	BIT 4	17	BIT 4
9	N.C.	16	BIT 3
10	N.C.	15	BIT 2
11	N.C.	14	BIT 1
12	GROUND	13	BIT 14 (LSB)

Note: N.C. means no connection.

NOTES:

- The switching threshold is typically V_{DD}/2.
- 10K Ω input impedance available. Consult factory.
- Using internal feedback resistor.
- Using the internal R_{feedback} with nulled external amplifier in a constant 25°C ambient. (Offset doubles every 10°C).
- The DAC331 Series is designed to be used only in those applications where the current output is virtual ground; i.e., the summing junction of an op amp in the inverting mode. The internal feedback resistor (R_{Feedback}) must be used to achieve temperature tracking.
- The power supply voltage must not exceed +10V.
- In case of discrepancy between package shown in photograph and package outline dimension, the mechanical outline is correct.

ORDERING INFORMATION

MODEL NUMBER	DESCRIPTION
DAC331C-12-1	Comm, 12-Bit, +5V Operation
DAC331B-12-1	Mil, 12-Bit, +5V Operation
DAC331C-14-1	Comm, 14-Bit, +5V Operation
DAC331B-14-1	Mil, 14-Bit, +5V Operation

