

High Speed CMOS Presettable Synchronous 4-Bit Binary Counters

Product Features:

- PI74FCT191/2191T is pin compatible with bipolar FAST™ Series at a higher speed and lower power consumption
- 25Ω series resistor on all outputs (FCT2XXX only)
- TTL input and output levels
- Low ground bounce outputs (25Ω series only)
- Extremely low static power
- Hysteresis on all inputs
- Industrial operating temperature range: -40°C to +85°C
- Packages available:
 - 16-pin 150 mil wide plastic QSOP (Q16)
 - 16-pin 300 mil wide plastic SOIC (S16)

Product Description:

Pericom Semiconductor's PI74FCT series of logic circuits are produced in the Company's advanced 0.6 micron CMOS technology, achieving industry leading speed grades. All PI74FCT2XXX devices have a built-in 25 ohm series resistor on all outputs to reduce noise due to reflections, thus eliminating the need for an external terminating resistor.

The PI74FCT191T is a high speed CMOS 4-bit binary up/down counter. It has a single clock with clock enable and up/down control inputs and ripple carry output. The 191 has asynchronous preload inputs which override the count inputs. All inputs have clamp diodes for undershoot noise suppression. All outputs have ground bounce suppression.

Logic Block Diagram

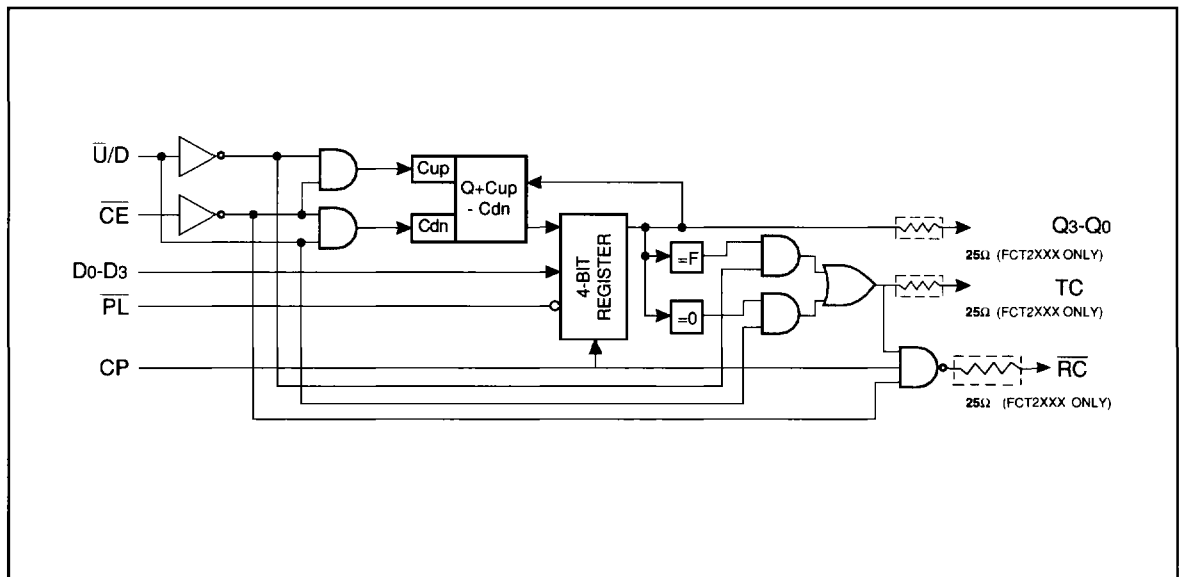



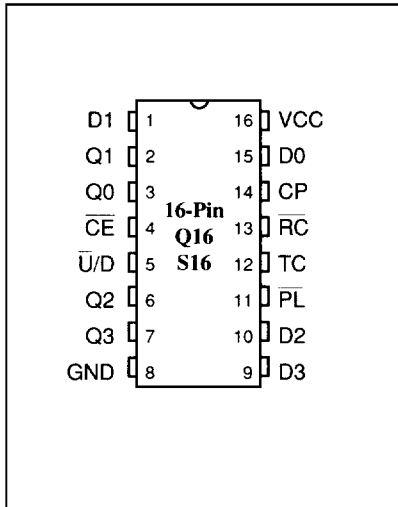

Product Pin Configurations
(All Pins Top View)



Product Pin Description

Pin Name	I/O	Description
D3-D0	I	Data Inputs
Q3-Q0	O	Data Outputs
\overline{PL}	I	Preload
$\overline{U/D}$	I	Up/Down Select
\overline{CE}	I	Count Enable
CP	I	Count Clock
TC	O	Terminal Count
\overline{RC}	O	Ripple Clock

Truth Table⁽¹⁾

Inputs				Outputs				Function
PL	$\overline{U/D}$	CP	\overline{CE}	DI	Q3-Q0	TC	\overline{RC}	
L	X	X	X	D3-D0	D3-D0	X	X	Load Data
H	L	↑	L	X	Q+1	L	H	Count Up
H	H	↑	L	X	Q-1	L	H	Count Down
H	X	X	H	X	Q	X	X	Count Inhibit
H	L	H	L	X	F	H	H	Count Up = 1111
H	L		L	X	F	H		Count Up = 1111
H	L	X	X	X	0-E	L	H	Count Up ≠ 1111
H	H	H	L	X	0	H	H	Count Down = 0000
H	H		L	X	0	H		Count Down = 0000
H	H	X	X	X	1-F	L	H	Count Down ≠ 0000

Notes:

- 1. H= High Voltage Level
- L= Low Voltage Level
- X= Don't Care
- Z= High Impedance



Maximum Ratings

(Above which the useful life may be impaired. For user guidelines, not tested.)

Storage Temperature	-65°C to +150°C
Ambient Temperature with Power Applied	-40°C to +85°C
Supply Voltage to Ground Potential (Inputs & Vcc Only)	-0.5V to +7.0V
Supply Voltage to Ground Potential (Outputs & D/O Only)	-0.5V to +7.0V
DC Input Voltage	-0.5V to +7.0V
DC Output Current	120 mA
Power Dissipation	0.5W

Note:

Stresses greater than those listed under MAXIMUM RATINGS may cause permanent damage to the device. This is a stress rating only and functional operation of the device at these or any other conditions above those indicated in the operational sections of this specification is not implied. Exposure to absolute maximum rating conditions for extended periods may affect reliability.

DC Electrical Characteristics (Over the Operating Range, TA = -40°C to +85°C, VCC = 5.0V ± 5%)

Parameters	Description	Test Conditions ⁽¹⁾		Min.	Typ ⁽²⁾	Max.	Units
VOH	Output HIGH Voltage	VCC = Min., VIN = VIH or VIL	IOH = -15.0 mA	2.4	3.0		V
VOL	Output LOW Current	VCC = Min., VIN = VIH or VIL	IOL = 48 mA		0.3	0.50	V
VOL	Output LOW Current	VCC = Min., VIN = VIH or VIL	IOL = 12 mA (25Ω Series)		0.3	0.50	V
VIH	Input HIGH Voltage	Guaranteed Logic HIGH Level		2.0			V
VIL	Input LOW Voltage	Guaranteed Logic LOW Level				0.8	V
IiH	Input HIGH Current	VCC = Max.	VIN = VCC			1	μA
IiL	Input LOW Current	VCC = Max.	VIN = GND			-1	μA
VIK	Clamp Diode Voltage	VCC = Min., IIN = -18 mA			-0.7	-1.2	V
Ioff	Power Down Disable	VCC = GND, VOUT = 4.5V		—	—	100	μA
Ios	Short Circuit Current	VCC = Max. ⁽³⁾ , VOUT = GND		-60	-120		mA
VH	Input Hysteresis				200		mV

Capacitance (TA = 25°C, f = 1 MHz)

Parameters ⁽⁴⁾	Description	Test Conditions	Typ	Max.	Units
CIN	Input Capacitance	VIN = 0V	6	10	pF
COU	Output Capacitance	VOUT = 0V	8	12	pF

Notes:

1. For Max. or Min. conditions, use appropriate value specified under Electrical Characteristics for the applicable device type.
2. Typical values are at VCC = 5.0V, +25°C ambient and maximum loading.
3. Not more than one output should be shorted at one time. Duration of the test should not exceed one second.
4. This parameter is determined by device characterization but is not production tested.

Power Supply Characteristics

Parameters	Description	Test Conditions ⁽¹⁾ Min.		Typ ⁽²⁾	Max.	Units	
I _{CC}	Quiescent Power Supply Current	V _{CC} = Max. Freq = 0	V _{IN} ≥ V _{CC} - 0.2V V _{IN} ≤ 0.2V		0.1	500	μA
ΔI _{CC}	Supply Current per Input @ TTL HIGH	V _{CC} = Max. Freq = 0	V _{IN} = 3.4V ⁽³⁾		0.5	2.0	mA
I _{CCD}	Supply Current per Input per MHz ⁽⁴⁾	V _{CC} = Max., Outputs Open and Enabled One Bit Toggling 50% Duty Cycle, other input at GND or V _{CC}	V _{IN} = V _{CC} V _{IN} = GND		0.15	0.25	mA/ MHz
I _C	Total Power Supply Current ⁽⁶⁾	V _{CC} = Max., Outputs Open Preset Mode $\overline{PL} = \overline{CE} = \overline{U/D} = CP = GND$ One Bit Toggling at f _i = 5MHz 50% Duty Cycle	V _{IN} = V _{CC} V _{IN} = GND	—	0.8	2.3	mA
			V _{IN} = 3.4V V _{IN} = GND	—	1.0	3.3	
		V _{CC} = Max., Outputs Open Preset Mode $\overline{PL} = \overline{CE} = \overline{U/D} = CP = GND$ Four Bits Toggling at f _i = 5MHz 50% Duty Cycle	V _{IN} = V _{CC} V _{IN} = GND	—	3.0	6.0 ⁽⁵⁾	
			V _{IN} = 3.4V V _{IN} = GND	—	4.0	10.0 ⁽⁵⁾	

Notes:

- For Max. or Min. conditions, use appropriate value specified under Electrical Characteristics for the applicable device.
- Typical values are at V_{CC} = 5.0V, +25°C ambient.
- Per TTL driven input (V_{IN} = 3.4V); all other inputs at V_{CC} or GND.
- This parameter is not directly testable, but is derived for use in Total Power Supply Calculations.
- Values for these conditions are examples of the I_{CC} formula. These limits are guaranteed but not tested.

$$6. I_C = I_{\text{QUIESCENT}} + I_{\text{INPUTS}} + I_{\text{DYNAMIC}}$$

$$I_C = I_{CC} + \Delta I_{CC} D_H N_T + I_{CCD} (f_{CP}/2 + f_i N_i)$$

I_{CC} = Quiescent Current

ΔI_{CC} = Power Supply Current for a TTL High Input (V_{IN} = 3.4V)

D_H = Duty Cycle for TTL Inputs High

N_T = Number of TTL Inputs at D_H

I_{CCD} = Dynamic Current Caused by an Input Transition Pair (HLH or LHL)

f_{CP} = Clock Frequency for Register Devices (Zero for Non-Register Devices)

f_i = Input Frequency

N_i = Number of Inputs at f_i

All currents are in milliamps and all frequencies are in megahertz.

Switching Characteristics (Over Operating Range)

Symbol	Description ⁽¹⁾	Conditions	191T 2191T		191AT 2191AT		191CT		Unit
			Min	Max	Min	Max	Min	Max	
tCPQ	Propagation Delay CP TO Qi	CL = 50 pF RL = 500 Ω	2.5	12	2.5	7.8	2.0	6.9	ns
tCPTC	Propagation Delay CP to TC		3.0	14	3.0	11.8	2.5	10.2	ns
tCPRC	Propagation Delay CP to RC		2.5	8.5	2.5	8.5	2.0	8.0	ns
tCERC	Propagation Delay CE to RC		2.0	8.0	2.0	7.2	1.5	6.8	ns
tUDRC	Propagation Delay U/D to RC		4.0	15	2.0	9.8	2.0	9.0	ns
tUDTC	Propagation Delay U/D to TC		3.0	11	3.0	7.2	2.0	6.8	ns
tDQ	Propagation Delay Di to Qi		2.0	14	2.0	9.1	2.0	8.5	ns
tPLQ	Propagation Delay PL to Qi		3.0	13	3.0	8.5	2.0	7.8	ns

Notes:

1. See Test Circuit and Waveforms.
2. Minimum limits are guaranteed but not tested on Propagation Delays.
3. This parameter guaranteed but not production tested.

Timing Characteristics (Over Operating Range)

Symbol	Description	Conditions	191T 2191T		191AT 2191AT		191CT 2191CT		Unit
			Min	Max	Min	Max	Min	Max	
tDPLS	Di to PL Setup	CL = 50 pF RL = 500 Ω	5.0		4.0		4.0		ns
tDPLH	Di to \overline{PL} Hold		1.5		1.5		1.5		ns
tCS	\overline{CE} to CP Setup		10		9.0		9.0		ns
tCH	\overline{CE} to CP Hold		0		0		0		ns
tUDCPS	$\overline{U/D}$ to CP Setup		12		10		10		ns
tUDCPH	$\overline{U/D}$ to CP Hold		0		0		0		ns
tCPW	Clock Pulse ⁽¹⁾ Width HIGH or LOW		5.0		4.0		4.0		ns
tPL	\overline{PL} LOW		6.0		5.5		5.5		ns
tPLCPR	\overline{PL} to CP Recovery		6.0		5.0		5.0		ns

Notes:

1. See Test Circuit and Waveforms.
2. Minimum limits are guaranteed but not tested on Propagation Delays.
3. This parameter guaranteed but not production tested.