

Photointerrupter, double-layer mold type

RPI-304

The RPI-304 is standard tall package photointerrupter. This product can be fix on PCB by snap.

●Application

Reel count sensor for VCR

●Features

- 1) Tall package (Optical axis 22.6mm)
- 2) Small package due to the double-layer mold
- 3) PPS package for heat resistance

●External dimensions (Units : mm)

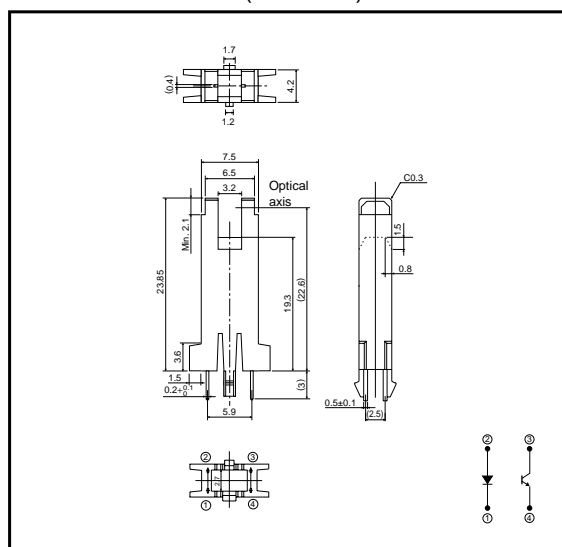

●Absolute maximum ratings (Ta = 25°C)

Parameter		Symbol	Limits	Unit
Input(LED)	Forward current	I_F	50	mA
	Reverse voltage	V_R	5	V
	Power dissipation	P_D	80	mW
Output (photo-transistor)	Collector-emitter voltage	V_{CE0}	30	V
	Emitter-collector voltage	V_{ECO}	4.5	V
	Collector current	I_C	30	mA
	Collector power dissipation	P_C	80	mW
Operating temperature		T_{opr}	-25~+85	°C
Storage temperature		T_{stg}	-30~+85	°C

Sensors

●Electrical and optical characteristics (Ta = 25°C)

	Parameter	Symbol	Min.	Typ.	Max.	Unit	Conditions
Input characteristics	Forward voltage	V_F	–	1.3	1.6	V	$I_F=50\text{mA}$
	Reverse current	I_R	–	–	10	μA	$V_R=5\text{V}$
Output characteristics	Dark current	I_{CE0}	–	–	0.5	μA	$V_{CE}=10\text{V}$
	Peak sensitivity wavelength	λ_P	–	800	–	nm	–
Transfer characteristics	Collector current	I_C	0.2	0.7	2.0	mA	$V_{CE}=5\text{V}, I_F=20\text{mA}$
	Collector-emitter saturation voltage	$V_{CE(sat)}$	–	–	0.4	V	$I_F=20\text{mA}, I_C=0.1\text{mA}$
	Response time	$t_r \cdot t_f$	–	10	–	μs	$V_{CC}=5\text{V}, I_F=20\text{mA}, R_L=100\Omega$

●Electrical and optical characteristic curves

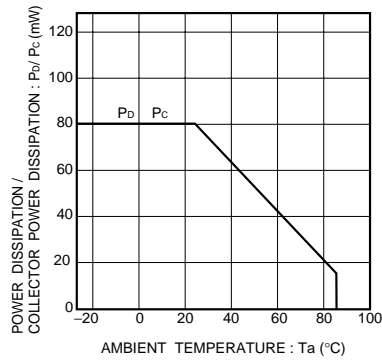

Fig.1 Power dissipation / collector power dissipation vs. ambient temperature

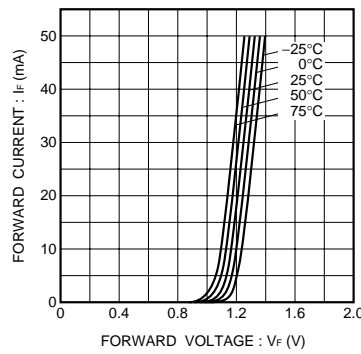

Fig.2 Forward current vs. forward voltage

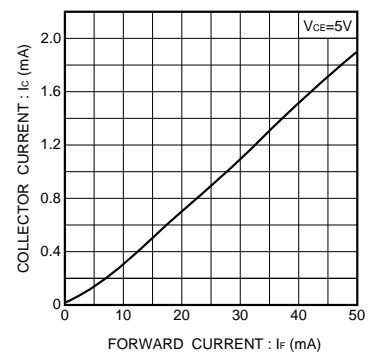

Fig.3 Collector current vs. forward current

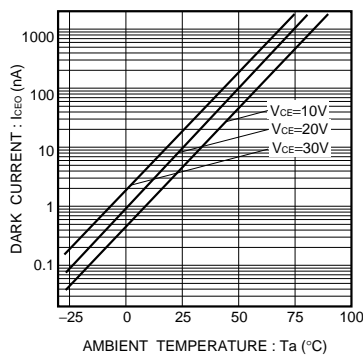

Fig.4 Dark current vs. ambient temperature

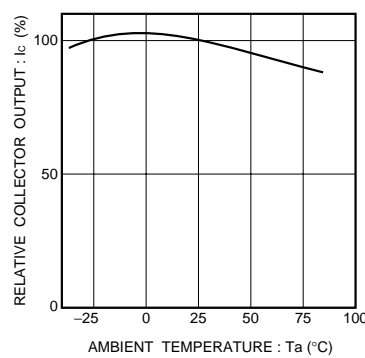

Fig.5 Relative output vs. ambient temperature

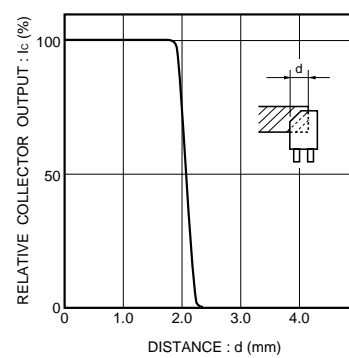

Fig.6 Relative output vs. distance

Sensors

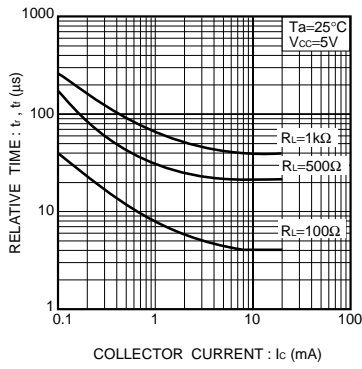

Fig.7 Response time vs. collector current

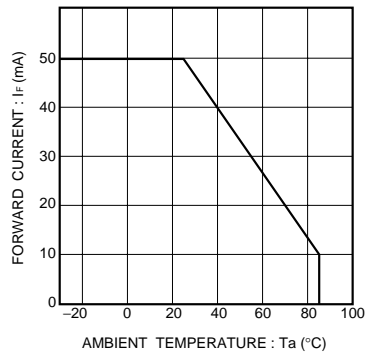

Fig.8 Forward current falloff

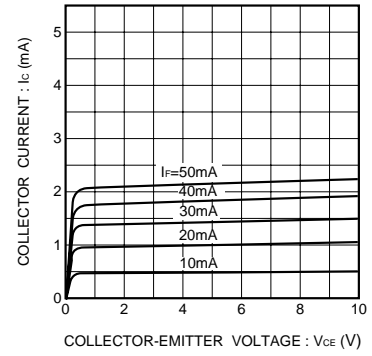

Fig.9 Output characteristics

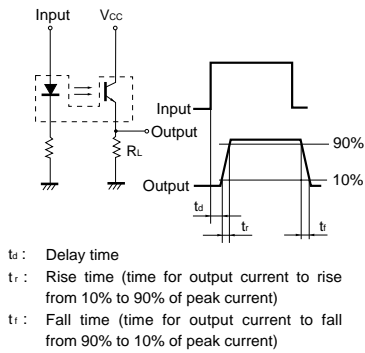

Fig.10 Response time measurement circuit