

# FLASH MEMORY

CMOS

## 8M (1M × 8/512K × 16) BIT

### MBM29LV800TA-70/-90/MBM29LV800BA-70/-90

#### ■ DESCRIPTION

The MBM29LV800TA/BA are a 8M-bit, 3.0 V-only Flash memory organized as 1M bytes of 8 bits each or 512K words of 16 bits each. The MBM29LV800TA/BA are offered in a 48-pin TSOP(I), 44-pin SOP, and 48-ball FBGA packages. These devices are designed to be programmed in-system with the standard system 3.0 V  $V_{CC}$  supply. 12.0 V  $V_{PP}$  and 5.0 V  $V_{CC}$  are not required for write or erase operations. The devices can also be reprogrammed in standard EPROM programmers.

The standard MBM29LV800TA/BA offer access times 70 ns and 90 ns, allowing operation of high-speed microprocessors without wait states. To eliminate bus contention the devices have separate chip enable ( $\overline{CE}$ ), write enable ( $\overline{WE}$ ), and output enable ( $\overline{OE}$ ) controls.

The MBM29LV800TA/BA are pin and command set compatible with JEDEC standard E<sup>2</sup>PROMs. Commands are written to the command register using standard microprocessor write timings. Register contents serve as input to an internal state-machine which controls the erase and programming circuitry. Write cycles also internally latch addresses and data needed for the programming and erase operations. Reading data out of the devices is similar to reading from 5.0 V and 12.0 V Flash or EPROM devices.

The MBM29LV800TA/BA are programmed by executing the program command sequence. This will invoke the Embedded Program Algorithm which is an internal algorithm that automatically times the program pulse widths and verifies proper cell margin. Typically, each sector can be programmed and verified in about 0.5 seconds. Erase is accomplished by executing the erase command sequence. This will invoke the Embedded Erase Algorithm which is an internal algorithm that automatically preprograms the array if it is not already programmed before executing the erase operation. During erase, the devices automatically time the erase pulse widths and verify proper cell margin.

*(Continued)*

#### ■ PRODUCT LINE UP

Part No.		MBM29LV800TA/MBM29LV800BA	
Ordering Part No.	$V_{CC} = 3.3\text{ V}$ $\begin{matrix} +0.3\text{ V} \\ -0.3\text{ V} \end{matrix}$	-70	—
	$V_{CC} = 3.0\text{ V}$ $\begin{matrix} +0.6\text{ V} \\ -0.3\text{ V} \end{matrix}$	—	-90
Max Address Access Time (ns)		70	90
Max $\overline{CE}$ Access Time (ns)		70	90
Max $\overline{OE}$ Access Time (ns)		30	35

# MBM29LV800TA-70/-90/MBM29LV800BA-70/-90

(Continued)

A sector is typically erased and verified in 1.0 second. (If already completely preprogrammed.)

The devices also feature a sector erase architecture. The sector mode allows each sector to be erased and reprogrammed without affecting other sectors. The MBM29LV800TA/BA are erased when shipped from the factory.

The devices feature single 3.0 V power supply operation for both read and write functions. Internally generated and regulated voltages are provided for the program and erase operations. A low  $V_{CC}$  detector automatically inhibits write operations on the loss of power. The end of program or erase is detected by  $\overline{\text{Data}}$  Polling of  $DQ_7$ , by the Toggle Bit feature on  $DQ_6$ , or the  $R\overline{Y}/B\overline{Y}$  output pin. Once the end of a program or erase cycle has been completed, the devices internally reset to the read mode.

Fujitsu's Flash technology combines years of EPROM and E<sup>2</sup>PROM experience to produce the highest levels of quality, reliability, and cost effectiveness. The MBM29LV800TA/BA memories electrically erase the entire chip or all bits within a sector simultaneously via Fowler-Nordhiem tunneling. The bytes/words are programmed one byte/word at a time using the EPROM programming mechanism of hot electron injection.

## ■ PACKAGES

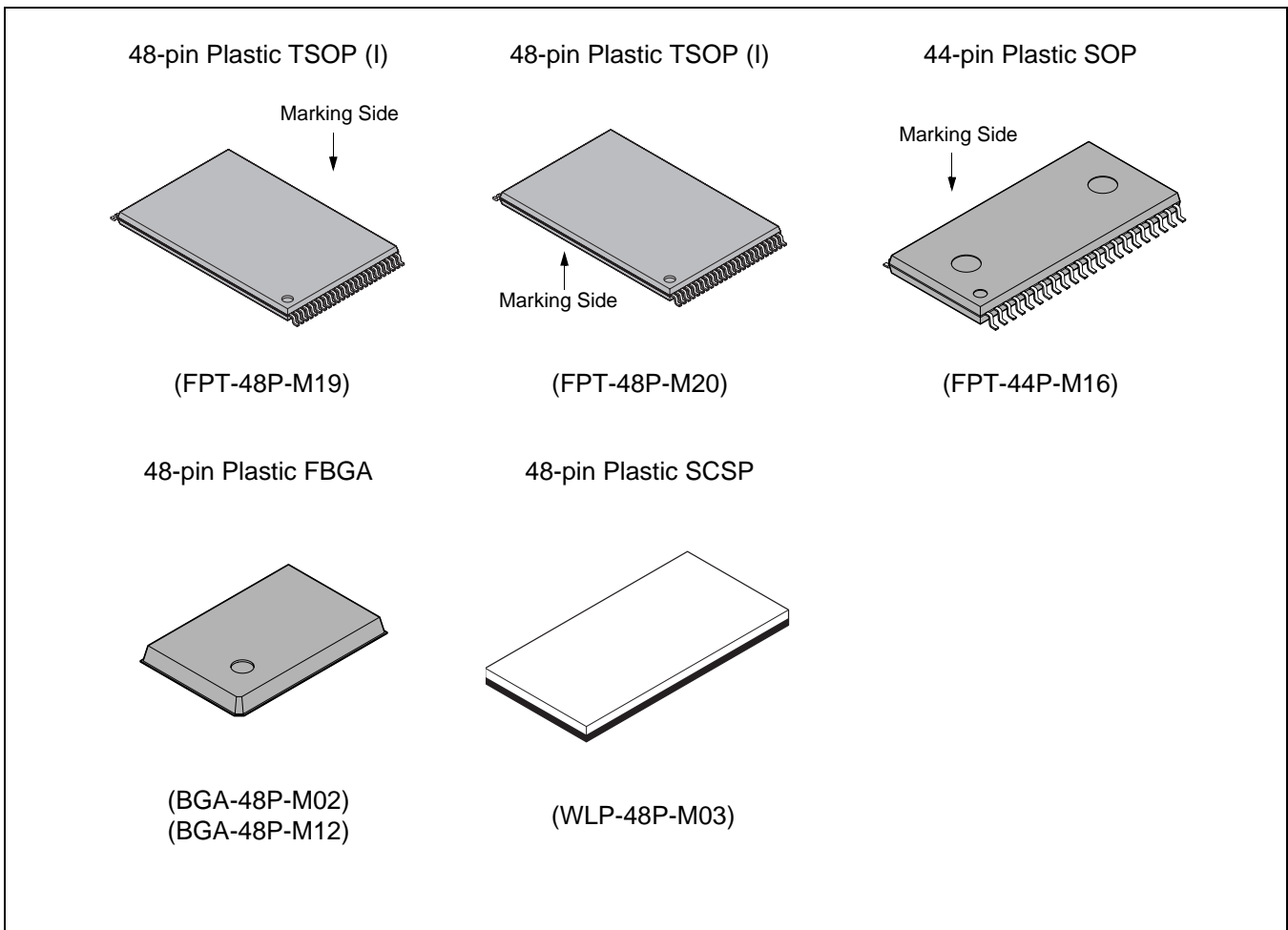

## ■ FEATURES

- **Single 3.0 V Read, Program, and Erase**  
Minimizes system level power requirements
- **Compatible with JEDEC-standard Commands**  
Uses same software commands as E<sup>2</sup>PROMs
- **Compatible with JEDEC-standard Worldwide Pinouts**  
48-pin TSOP(I) (Package suffix: PFTN – Normal Bend Type, PFTR – Reversed Bend Type)  
44-pin SOP (Package suffix: PF)  
48-ball FBGA (Package suffix: PBT)  
48-ball SCSP (Package suffix: PW)
- **Minimum 100,000 Program/Erase Cycles**
- **High performance**  
70 ns maximum access time
- **Sector Erase Architecture**  
One 8K word, two 4K words, one 16K word, and fifteen 32K words sectors in word mode  
One 16K byte, two 8K bytes, one 32K byte, and fifteen 64K bytes sectors in byte mode  
Any combination of sectors can be concurrently erased. Also supports full chip erase
- **Boot Code Sector Architecture**  
T = Top sector  
B = Bottom sector
- **Embedded Erase™\* Algorithms**  
Automatically pre-programs and erases the chip or any sector
- **Embedded Program™\* Algorithms**  
Automatically writes and verifies data at specified address
- **Data Polling and Toggle Bit Feature for Detection of Program or Erase Cycle Completion**
- **Ready/Busy Output (RY/BY)**  
Hardware method for detection of program or erase cycle completion
- **Automatic Sleep Mode**  
When addresses remain stable, automatically switch themselves to low power mode
- **Low V<sub>CC</sub> Write Inhibit ≤ 2.5 V**
- **Erase Suspend/Resume**  
Suspends the erase operation to allow a read in another sector within the same device
- **Sector Protection**  
Hardware method disables any combination of sectors from program or erase operations
- **Sector Protection Set Function by Extended Sector Protect Command**
- **Temporary Sector Unprotection**  
Temporary sector unprotection via the  $\overline{\text{RESET}}$  pin

\*: Embedded Erase™ and Embedded Program™ are trademarks of Advanced Micro Devices, Inc.

# MBM29LV800TA-70/-90/MBM29LV800BA-70/-90

## PIN ASSIGNMENTS

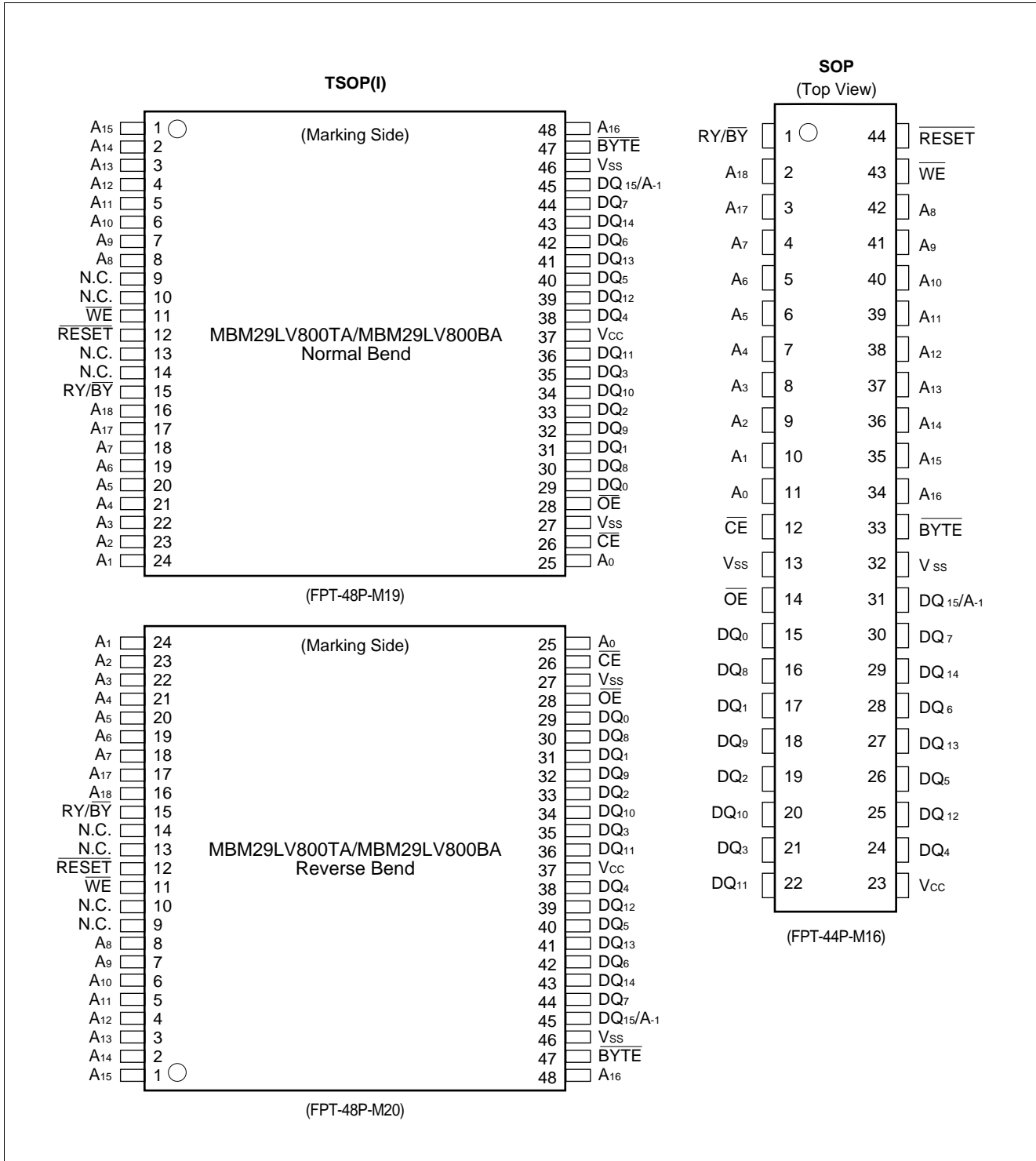

(Continued)

# MBM29LV800TA-70/-90/MBM29LV800BA-70/-90

(Continued)

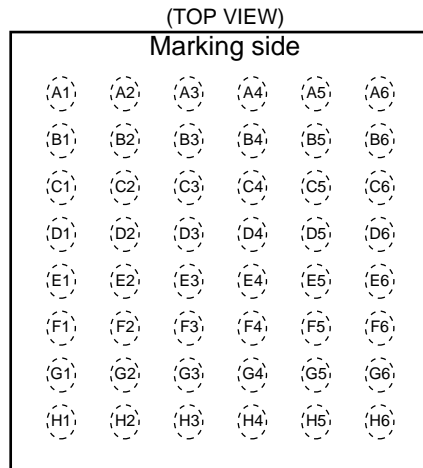

A1	A <sub>3</sub>	A2	A <sub>7</sub>	A3	RY/ $\overline{\text{BY}}$	A4	$\overline{\text{WE}}$	A5	A <sub>9</sub>	A6	A <sub>13</sub>
B1	A <sub>4</sub>	B2	A <sub>17</sub>	B3	N.C.	B4	$\overline{\text{RESET}}$	B5	A <sub>8</sub>	B6	A <sub>12</sub>
C1	A <sub>2</sub>	C2	A <sub>6</sub>	C3	A <sub>18</sub>	C4	N.C.	C5	A <sub>10</sub>	C6	A <sub>14</sub>
D1	A <sub>1</sub>	D2	A <sub>5</sub>	D3	N.C.	D4	N.C.	D5	A <sub>11</sub>	D6	A <sub>15</sub>
E1	A <sub>0</sub>	E2	DQ <sub>0</sub>	E3	DQ <sub>2</sub>	E4	DQ <sub>5</sub>	E5	DQ <sub>7</sub>	E6	A <sub>16</sub>
F1	$\overline{\text{CE}}$	F2	DQ <sub>8</sub>	F3	DQ <sub>10</sub>	F4	DQ <sub>12</sub>	F5	DQ <sub>14</sub>	F6	$\overline{\text{BYTE}}$
G1	$\overline{\text{OE}}$	G2	DQ <sub>9</sub>	G3	DQ <sub>11</sub>	G4	V <sub>CC</sub>	G5	DQ <sub>13</sub>	G6	DQ <sub>15/A-1</sub>
H1	V <sub>SS</sub>	H2	DQ <sub>1</sub>	H3	DQ <sub>3</sub>	H4	DQ <sub>4</sub>	H5	DQ <sub>6</sub>	H6	V <sub>SS</sub>

SCSP  
(Top View)  
Marking side

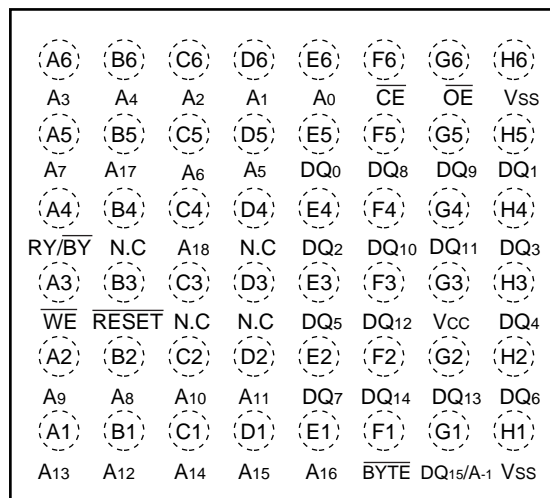

# MBM29LV800TA-70/-90/MBM29LV800BA-70/-90

## ■ PIN DESCRIPTION

Pin name	Function
A <sub>-1</sub> , A <sub>0</sub> to A <sub>18</sub>	Address Inputs
DQ <sub>0</sub> to DQ <sub>15</sub>	Data Inputs/Outputs
$\overline{\text{CE}}$	Chip Enable
$\overline{\text{OE}}$	Output Enable
$\overline{\text{WE}}$	Write Enable
RY/ $\overline{\text{BY}}$	Ready/Busy Output
$\overline{\text{RESET}}$	Hardware Reset Pin/Temporary Sector Unprotection
BYTE	Selects 8-bit or 16-bit mode
V <sub>SS</sub>	Device Ground
V <sub>CC</sub>	Device Power Supply
N.C.	No Internal Connection

# MBM29LV800TA-70/-90/MBM29LV800BA-70/-90

## ■ BLOCK DIAGRAM

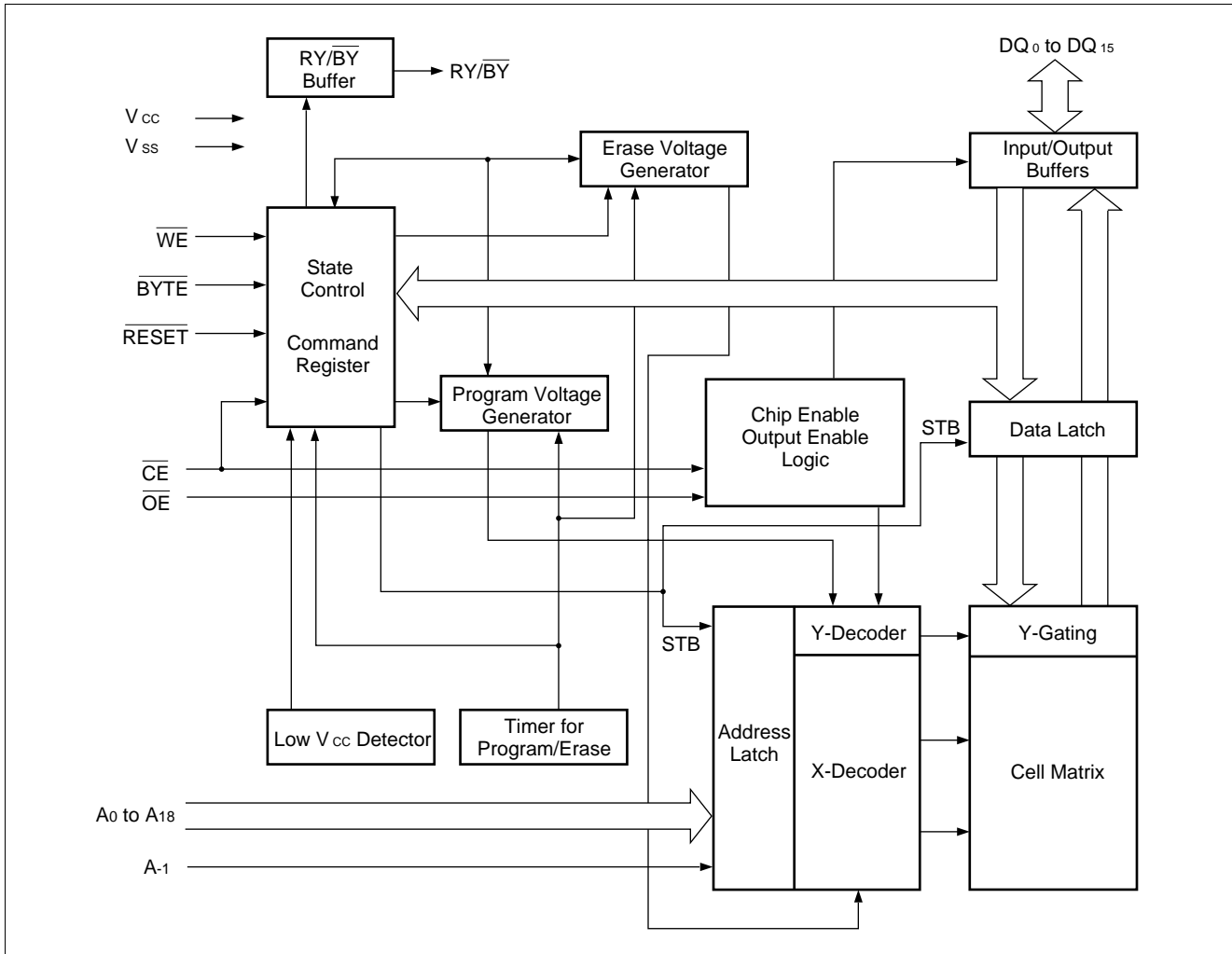

## ■ LOGIC SYMBOL

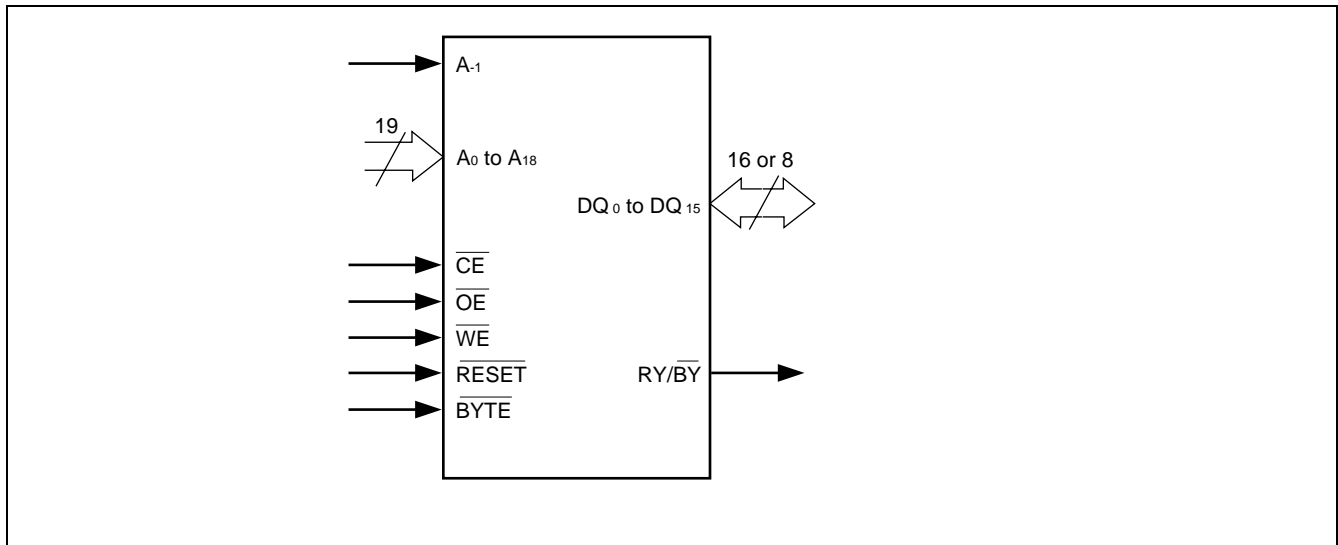

# MBM29LV800TA-70/-90/MBM29LV800BA-70/-90

## ■ DEVICE BUS OPERATION

MBM29LV800TA/800BA User Bus Operations Table ( $\overline{\text{BYTE}} = V_{IH}$ )

Operation	$\overline{\text{CE}}$	$\overline{\text{OE}}$	$\overline{\text{WE}}$	A <sub>0</sub>	A <sub>1</sub>	A <sub>6</sub>	A <sub>9</sub>	DQ <sub>0</sub> to DQ <sub>15</sub>	$\overline{\text{RESET}}$
Auto-Select Manufacturer Code *1	L	L	H	L	L	L	V <sub>ID</sub>	Code	H
Auto-Select Device Code *1	L	L	H	H	L	L	V <sub>ID</sub>	Code	H
Read *3	L	L	H	A <sub>0</sub>	A <sub>1</sub>	A <sub>6</sub>	A <sub>9</sub>	D <sub>OUT</sub>	H
Standby	H	X	X	X	X	X	X	High-Z	H
Output Disable	L	H	H	X	X	X	X	High-Z	H
Write (Program/Erase)	L	H	L	A <sub>0</sub>	A <sub>1</sub>	A <sub>6</sub>	A <sub>9</sub>	D <sub>IN</sub>	H
Enable Sector Protection *2, *4	L	V <sub>ID</sub>		L	H	L	V <sub>ID</sub>	X	H
Verify Sector Protection *2, *4	L	L	H	L	H	L	V <sub>ID</sub>	Code	H
Temporary Sector Unprotection*5	X	X	X	X	X	X	X	X	V <sub>ID</sub>
Reset (Hardware)/Standby	X	X	X	X	X	X	X	High-Z	L

**Legend:** L = V<sub>IL</sub>, H = V<sub>IH</sub>, X = V<sub>IL</sub> or V<sub>IH</sub>,  = Pulse input. See “■DC CHARACTERISTICS” for voltage levels.

\*1: Manufacturer and device codes may also be accessed via a command register write sequence. See “MBM29LV800TA/BA Standard Command Definitions Table”.

\*2: Refer to “7. Sector Protection” in “■FUNCTIONAL DESCRIPTIONS”.

\*3:  $\overline{\text{WE}}$  can be V<sub>IL</sub> if  $\overline{\text{OE}}$  is V<sub>IL</sub>,  $\overline{\text{OE}}$  at V<sub>IH</sub> initiates the write operations.

\*4: V<sub>CC</sub> = 3.3 V ± 10%

\*5: It is also used for the extended sector protection.

MBM29LV800TA/800BA User Bus Operations Table ( $\overline{\text{BYTE}} = V_{IL}$ )

Operation	$\overline{\text{CE}}$	$\overline{\text{OE}}$	$\overline{\text{WE}}$	DQ <sub>15</sub> / A <sub>-1</sub>	A <sub>0</sub>	A <sub>1</sub>	A <sub>6</sub>	A <sub>9</sub>	DQ <sub>0</sub> to DQ <sub>7</sub>	$\overline{\text{RESET}}$
Auto-Select Manufacturer Code *1	L	L	H	L	L	L	L	V <sub>ID</sub>	Code	H
Auto-Select Device Code *1	L	L	H	L	H	L	L	V <sub>ID</sub>	Code	H
Read *3	L	L	H	A <sub>-1</sub>	A <sub>0</sub>	A <sub>1</sub>	A <sub>6</sub>	A <sub>9</sub>	D <sub>OUT</sub>	H
Standby	H	X	X	X	X	X	X	X	High-Z	H
Output Disable	L	H	H	X	X	X	X	X	High-Z	H
Write (Program/Erase)	L	H	L	A <sub>-1</sub>	A <sub>0</sub>	A <sub>1</sub>	A <sub>6</sub>	A <sub>9</sub>	D <sub>IN</sub>	H
Enable Sector Protection *2, *4	L	V <sub>ID</sub>		L	L	H	L	V <sub>ID</sub>	X	H
Verify Sector Protection *2, *4	L	L	H	L	L	H	L	V <sub>ID</sub>	Code	H
Temporary Sector Unprotection *5	X	X	X	X	X	X	X	X	X	V <sub>ID</sub>
Reset (Hardware)/Standby	X	X	X	X	X	X	X	X	High-Z	L

**Legend:** L = V<sub>IL</sub>, H = V<sub>IH</sub>, X = V<sub>IL</sub> or V<sub>IH</sub>,  = Pulse input. See “■DC CHARACTERISTICS” for voltage levels.

\*1: Manufacturer and device codes may also be accessed via a command register write sequence. See “MBM29LV800TA/BA Standard Command Definitions Table”.

\*2: Refer to “7. Sector Protection” in “■FUNCTIONAL DESCRIPTIONS”.

\*3:  $\overline{\text{WE}}$  can be V<sub>IL</sub> if  $\overline{\text{OE}}$  is V<sub>IL</sub>,  $\overline{\text{OE}}$  at V<sub>IH</sub> initiates the write operations.

\*4: V<sub>CC</sub> = 3.3 V ± 10%

\*5: It is also used for the extended sector protection.

# MBM29LV800TA-70/-90/MBM29LV800BA-70/-90

**MBM29LV800TA/800BA Sector Protection Verify Autoselect Codes Table**

Type		A <sub>12</sub> to A <sub>18</sub>	A <sub>6</sub>	A <sub>1</sub>	A <sub>0</sub>	A <sub>-1</sub> <sup>*1</sup>	Code (HEX)
Manufacturer's Code		X	V <sub>IL</sub>	V <sub>IL</sub>	V <sub>IL</sub>	V <sub>IL</sub>	04h
Device Code	MBM29LV800TA	Byte	X	V <sub>IL</sub>	V <sub>IL</sub>	V <sub>IH</sub>	DAh
		Word				X	22DAh
	MBM29LV800BA	Byte	X	V <sub>IL</sub>	V <sub>IL</sub>	V <sub>IH</sub>	5Bh
		Word				X	225Bh
Sector Protection		Sector Addresses	V <sub>IL</sub>	V <sub>IH</sub>	V <sub>IL</sub>	V <sub>IL</sub>	01h <sup>*2</sup>

\*1: A<sub>-1</sub> is for Byte mode. At Byte mode, DQ<sub>8</sub> to DQ<sub>14</sub> are High-Z and DQ<sub>15</sub> is A<sub>-1</sub>, the lowest address.

\*2: Outputs 01h at protected sector addresses and outputs 00h at unprotected sector addresses.

**Expanded Autoselect Code Table**

Type		Code	DQ <sub>15</sub>	DQ <sub>14</sub>	DQ <sub>13</sub>	DQ <sub>12</sub>	DQ <sub>11</sub>	DQ <sub>10</sub>	DQ <sub>9</sub>	DQ <sub>8</sub>	DQ <sub>7</sub>	DQ <sub>6</sub>	DQ <sub>5</sub>	DQ <sub>4</sub>	DQ <sub>3</sub>	DQ <sub>2</sub>	DQ <sub>1</sub>	DQ <sub>0</sub>	
Manufacturer's Code		04h	A <sub>-1</sub> /0	0	0	0	0	0	0	0	0	0	0	0	0	1	0	0	
Device Code	MBM29LV800TA	(B)*	DAh	A <sub>-1</sub>	HI-Z	HI-Z	HI-Z	HI-Z	HI-Z	HI-Z	1	1	0	1	1	0	1	0	
		(W)	22DAh	0	0	1	0	0	0	1	0	1	1	0	1	1	0	1	0
	MBM29LV800BA	(B)*	5Bh	A <sub>-1</sub>	HI-Z	HI-Z	HI-Z	HI-Z	HI-Z	HI-Z	HI-Z	0	1	0	1	1	0	1	1
		(W)	225Bh	0	0	1	0	0	0	1	0	0	1	0	1	1	0	1	1
Sector Protection		01h	A <sub>-1</sub> /0	0	0	0	0	0	0	0	0	0	0	0	0	0	0	1	

\* : At Byte mode, DQ<sub>8</sub> to DQ<sub>14</sub> are High-Z and DQ<sub>15</sub> is A<sub>-1</sub>, the lowest address.

(B): Byte mode

(W): Word mode

HI-Z: High-Z

# MBM29LV800TA-70/-90/MBM29LV800BA-70/-90

MBM29LV800TA/800BA Standard Command Definitions Table

Command Sequence		Bus Write Cycles Req'd	First Bus Write Cycle		Second Bus Write Cycle		Third Bus Write Cycle		Fourth Bus Read/Write Cycle		Fifth Bus Write Cycle		Sixth Bus Write Cycle	
			Addr.	Data	Addr.	Data	Addr.	Data	Addr.	Data	Addr.	Data	Addr.	Data
Read/Reset	Word	1	XXXh	F0h	—	—	—	—	—	—	—	—	—	—
	Byte		—	—	—	—	—	—	—	—	—	—	—	—
Read/Reset	Word	3	555h	AAh	2AAh	55h	555h	F0h	RA	RD	—	—	—	—
	Byte		AAAh		555h		AAAh							
Autoselect	Word	3	555h	AAh	2AAh	55h	555h	90h	—	—	—	—	—	—
	Byte		AAAh		555h		AAAh							
Program	Word	4	555h	AAh	2AAh	55h	555h	A0h	PA	PD	—	—	—	—
	Byte		AAAh		555h		AAAh							
Chip Erase	Word	6	555h	AAh	2AAh	55h	555h	80h	555h	AAh	2AAh	55h	555h	10h
	Byte		AAAh		555h		AAAh		555h					
Sector Erase	Word	6	555h	AAh	2AAh	55h	555h	80h	555h	AAh	2AAh	55h	SA	30h
	Byte		AAAh		555h		AAAh		555h					
Sector Erase Suspend			Erase can be suspended during sector erase with Addr. ("H" or "L"). Data (B0h)											
Sector Erase Resume			Erase can be resumed after suspend with Addr. ("H" or "L"). Data (30h)											

- Notes:**
- Address bits A<sub>11</sub> to A<sub>18</sub> = X = "H" or "L" for all address commands except or Program Address (PA) and Sector Address (SA)
  - Bus operations are defined in "MBM29LV800TA/BA User Bus Operations Tables ( $\overline{\text{BYTE}} = V_{IH}$  and  $\overline{\text{BYTE}} = V_{IL}$ )".
  - RA = Address of the memory location to be read  
PA = Address of the memory location to be programmed  
Addresses are latched on the falling edge of the  $\overline{\text{WE}}$  pulse.  
SA = Address of the sector to be erased. The combination of A<sub>18</sub>, A<sub>17</sub>, A<sub>16</sub>, A<sub>15</sub>, A<sub>14</sub>, A<sub>13</sub>, and A<sub>12</sub> will uniquely select any sector.
  - RD = Data read from location RA during read operation.  
PD = Data to be programmed at location PA. Data is latched on the falling edge of  $\overline{\text{WE}}$ .
  - The system should generate the following address patterns:  
Word Mode: 555h or 2AAh to addresses A<sub>0</sub> to A<sub>10</sub>  
Byte Mode: AAAh or 555h to addresses A<sub>-1</sub> and A<sub>0</sub> to A<sub>10</sub>
  - Both Read/Reset commands are functionally equivalent, resetting the device to the read mode.
  - Command combinations not described in "MBM29LV800TA/800BA Standard Command Definitions Table" and "MBM29LV800TA/BA Extended Command Definitions Table" are illegal.

# MBM29LV800TA-70/-90/MBM29LV800BA-70/-90

**MBM29LV800TA/BA Extended Command Definitions Table**

Command Sequence		Bus Write Cycles Req'd	First Bus Write Cycle		Second Bus Write Cycle		Third Bus Write Cycle		Fourth Bus Read Cycle	
			Addr	Data	Addr	Data	Addr	Data	Addr	Data
Set to Fast Mode	Word	3	555h	AAh	2AAh	55h	555h	20h	—	—
	Byte		AAAh		555h		AAAh			
Fast Program* <sup>1</sup>	Word	2	XXXh	A0h	PA	PD	—	—	—	—
	Byte		XXXh							
Reset from Fast Mode * <sup>1</sup>	Word	2	XXXh	90h	XXXh	F0h* <sup>3</sup>	—	—	—	—
	Byte		XXXh							
Extended Sector Protect* <sup>2</sup>	Word	4	XXXh	60h	SPA	60h	SPA	40h	SPA	SD
	Byte									

SPA : Sector address to be protected. Set sector address (SA) and (A<sub>6</sub>, A<sub>1</sub>, A<sub>0</sub>) = (0, 1, 0).

SD : Sector protection verify data. Output 01h at protected sector addresses and output 00h at unprotected sector addresses.

\*1: This command is valid while Fast Mode.

\*2: This command is valid while  $\overline{\text{RESET}} = V_{\text{DD}}$ .

\*3: This data "00h" is also acceptable.

## ■ FLEXIBLE SECTOR-ERASE ARCHITECTURE

- One 16K byte, two 8K bytes, one 32K byte, and fifteen 64K bytes
- Individual-sector, multiple-sector, or bulk-erase capability
- Individual or multiple-sector protection is user definable.

	(x8)	(x16)
16K byte	FFFFFh	7FFFFh
8K byte	FBFFFh	7DFFFh
8K byte	F9FFFh	7CFFFh
32K byte	F7FFFh	7BFFFh
64K byte	EFFFFh	77FFFh
64K byte	DFFFFh	6FFFFh
64K byte	CFFFFh	67FFFh
64K byte	BFFFFh	5FFFFh
64K byte	AFFFFh	57FFFh
64K byte	9FFFFh	4FFFFh
64K byte	8FFFFh	47FFFh
64K byte	7FFFFh	3FFFFh
64K byte	6FFFFh	37FFFh
64K byte	5FFFFh	2FFFFh
64K byte	4FFFFh	27FFFh
64K byte	3FFFFh	1FFFFh
64K byte	2FFFFh	17FFFh
64K byte	1FFFFh	0FFFFh
64K byte	0FFFFh	07FFFh
64K byte	00000h	00000h

**MBM29LV800TA Sector Architecture**

	(x8)	(x16)
64K byte	FFFFFh	7FFFFh
64K byte	EFFFFh	77FFFh
64K byte	DFFFFh	6FFFFh
64K byte	CFFFFh	67FFFh
64K byte	BFFFFh	5FFFFh
64K byte	AFFFFh	57FFFh
64K byte	9FFFFh	4FFFFh
64K byte	8FFFFh	47FFFh
64K byte	7FFFFh	3FFFFh
64K byte	6FFFFh	37FFFh
64K byte	5FFFFh	2FFFFh
64K byte	4FFFFh	27FFFh
64K byte	3FFFFh	1FFFFh
64K byte	2FFFFh	17FFFh
64K byte	1FFFFh	0FFFFh
64K byte	0FFFFh	07FFFh
32K byte	07FFFh	03FFFh
8K byte	05FFFh	02FFFh
8K byte	03FFFh	01FFFh
16K byte	00000h	00000h

**MBM29LV800BA Sector Architecture**

# MBM29LV800TA-70/-90/MBM29LV800BA-70/-90

Sector Address Table (MBM29LV800TA)

Sector Address	A <sub>18</sub>	A <sub>17</sub>	A <sub>16</sub>	A <sub>15</sub>	A <sub>14</sub>	A <sub>13</sub>	A <sub>12</sub>	Address Range (×8)	Address Range (×16)
SA0	0	0	0	0	X	X	X	00000h to 0FFFFh	00000h to 07FFFh
SA1	0	0	0	1	X	X	X	10000h to 1FFFFh	08000h to 0FFFFh
SA2	0	0	1	0	X	X	X	20000h to 2FFFFh	10000h to 17FFFh
SA3	0	0	1	1	X	X	X	30000h to 3FFFFh	18000h to 1FFFFh
SA4	0	1	0	0	X	X	X	40000h to 4FFFFh	20000h to 27FFFh
SA5	0	1	0	1	X	X	X	50000h to 5FFFFh	28000h to 2FFFFh
SA6	0	1	1	0	X	X	X	60000h to 6FFFFh	30000h to 37FFFh
SA7	0	1	1	1	X	X	X	70000h to 7FFFFh	38000h to 3FFFFh
SA8	1	0	0	0	X	X	X	80000h to 8FFFFh	40000h to 47FFFh
SA9	1	0	0	1	X	X	X	90000h to 9FFFFh	48000h to 4FFFFh
SA10	1	0	1	0	X	X	X	A0000h to AFFFFh	50000h to 57FFFh
SA11	1	0	1	1	X	X	X	B0000h to BFFFFh	58000h to 5FFFFh
SA12	1	1	0	0	X	X	X	C0000h to CFFFFh	60000h to 67FFFh
SA13	1	1	0	1	X	X	X	D0000h to DFFFFh	68000h to 6FFFFh
SA14	1	1	1	0	X	X	X	E0000h to EFFFFh	70000h to 77FFFh
SA15	1	1	1	1	0	X	X	F0000h to F7FFFh	78000h to 7BFFFh
SA16	1	1	1	1	1	0	0	F8000h to F9FFFh	7C000h to 7CFFFh
SA17	1	1	1	1	1	0	1	FA000h to FBFFFh	7D000h to 7DFFFh
SA18	1	1	1	1	1	1	X	FC000h to FFFFFh	7E000h to 7FFFFh

# MBM29LV800TA-70/-90/MBM29LV800BA-70/-90

Sector Address Table (MBM29LV800BA)

Sector Address	A <sub>18</sub>	A <sub>17</sub>	A <sub>16</sub>	A <sub>15</sub>	A <sub>14</sub>	A <sub>13</sub>	A <sub>12</sub>	Address Range (×8)	Address Range (×16)
SA0	0	0	0	0	0	0	X	0000h to 03FFFh	0000h to 01FFFh
SA1	0	0	0	0	0	1	0	0400h to 05FFFh	0200h to 02FFFh
SA2	0	0	0	0	0	1	1	0600h to 07FFFh	0300h to 03FFFh
SA3	0	0	0	0	1	X	X	0800h to 0FFFFh	0400h to 07FFFh
SA4	0	0	0	1	X	X	X	1000h to 1FFFFh	0800h to 0FFFFh
SA5	0	0	1	0	X	X	X	2000h to 2FFFFh	1000h to 17FFFh
SA6	0	0	1	1	X	X	X	3000h to 3FFFFh	1800h to 1FFFFh
SA7	0	1	0	0	X	X	X	4000h to 4FFFFh	2000h to 27FFFh
SA8	0	1	0	1	X	X	X	5000h to 5FFFFh	2800h to 2FFFFh
SA9	0	1	1	0	X	X	X	6000h to 6FFFFh	3000h to 37FFFh
SA10	0	1	1	1	X	X	X	7000h to 7FFFFh	3800h to 3FFFFh
SA11	1	0	0	0	X	X	X	8000h to 8FFFFh	4000h to 47FFFh
SA12	1	0	0	1	X	X	X	9000h to 9FFFFh	4800h to 4FFFFh
SA13	1	0	1	0	X	X	X	A000h to AFFFFh	5000h to 57FFFh
SA14	1	0	1	1	X	X	X	B000h to BFFFFh	5800h to 5FFFFh
SA15	1	1	0	0	X	X	X	C000h to CFFFFh	6000h to 67FFFh
SA16	1	1	0	1	X	X	X	D000h to DFFFFh	6800h to 6FFFFh
SA17	1	1	1	0	X	X	X	E000h to EFFFFh	7000h to 77FFFh
SA18	1	1	1	1	X	X	X	F000h to FFFFFh	7800h to 7FFFFh

## ■ FUNCTIONAL DESCRIPTION

### 1. Read Mode

The MBM29LV800TA/BA have two control functions which must be satisfied in order to obtain data at the outputs.  $\overline{CE}$  is the power control and should be used for a device selection.  $\overline{OE}$  is the output control and should be used to gate data to the output pins if a device is selected.

Address access time ( $t_{ACC}$ ) is equal to the delay from stable addresses to valid output data. The chip enable access time ( $t_{CE}$ ) is the delay from stable addresses and stable  $\overline{CE}$  to valid data at the output pins. The output enable access time is the delay from the falling edge of  $\overline{OE}$  to valid data at the output pins. (Assuming the addresses have been stable for at least  $t_{ACC-tOE}$  time.) When reading out a data without changing addresses after power-up, it is necessary to input hardware reset or change  $\overline{CE}$  pin from “H” or “L”

### 2. Standby Mode

There are two ways to implement the standby mode on the MBM29LV800TA/BA devices, one using both the  $\overline{CE}$  and  $\overline{RESET}$  pins; the other via the  $\overline{RESET}$  pin only.

When using both pins, a CMOS standby mode is achieved with  $\overline{CE}$  and  $\overline{RESET}$  inputs both held at  $V_{CC} \pm 0.3 V$ . Under this condition the current consumed is less than  $5 \mu A$ . The device can be read with standard access time ( $t_{CE}$ ) from either of these standby modes. During Embedded Algorithm operation,  $V_{CC}$  active current ( $I_{CC2}$ ) is required even  $\overline{CE} = \text{“H”}$ .

When using the  $\overline{RESET}$  pin only, a CMOS standby mode is achieved with  $\overline{RESET}$  input held at  $V_{SS} \pm 0.3 V$  ( $\overline{CE} = \text{“H”}$  or “L”). Under this condition the current is consumed is less than  $5 \mu A$ . Once the  $\overline{RESET}$  pin is taken high, the device requires  $t_{RH}$  of wake up time before outputs are valid for read access.

In the standby mode the outputs are in the high impedance state, independent of the  $\overline{OE}$  input.

### 3. Automatic Sleep Mode

There is a function called automatic sleep mode to restrain power consumption during read-out of MBM29LV800TA/800BA data. This mode can be used effectively with an application requested low power consumption such as handy terminals.

To activate this mode, MBM29LV800TA/800BA automatically switch themselves to low power mode when MBM29LV800TA/800BA addresses remain stably during access time of 150 ns. It is not necessary to control  $\overline{CE}$ ,  $\overline{WE}$ , and  $\overline{OE}$  on the mode. Under the mode, the current consumed is typically  $1 \mu A$  (CMOS Level).

Since the data are latched during this mode, the data are read-out continuously. If the addresses are changed, the mode is canceled automatically and MBM29LV800TA/800BA read-out the data for changed addresses.

### 4. Output Disable

With the  $\overline{OE}$  input at a logic high level ( $V_{IH}$ ), output from the devices are disabled. This will cause the output pins to be in a high impedance state.

### 5. Autoselect

The autoselect mode allows the reading out of a binary code from the devices and will identify its manufacturer and type. This mode is intended for use by programming equipment for the purpose of automatically matching the devices to be programmed with its corresponding programming algorithm. This mode is functional over the entire temperature range of the devices.

To activate this mode, the programming equipment must force  $V_{ID}$  (11.5 V to 12.5 V) on address pin  $A_9$ . Two identifier bytes may then be sequenced from the devices outputs by toggling address  $A_0$  from  $V_{IL}$  to  $V_{IH}$ . All addresses are DON'T CARES except  $A_0$ ,  $A_1$ ,  $A_6$ , and  $A_{-1}$ . (See “MBM29LV800TA/BA Sector Protection Verify Autoselect Codes Table” in “■DEVICE BUS OPERATION”.)

The manufacturer and device codes may also be read via the command register, for instances when the MBM29LV800TA/BA are erased or programmed in a system without access to high voltage on the  $A_9$  pin. The command sequence is illustrated in “MBM29LV800TA/BA Standard Command Definitions Table” (“■DEVICE BUS OPERATION”). (Refer to “2. Autoselect Command” in “■COMMAND DEFINITIONS”).

# MBM29LV800TA-70/-90/MBM29LV800BA-70/-90

Byte 0 ( $A_0 = V_{IL}$ ) represents the manufacturer's code (Fujitsu = 04h) and ( $A_0 = V_{IH}$ ) represents the device identifier code (MBM29LV800TA = DAh and MBM29LV800BA = 5Bh for  $\times 8$  mode; MBM29LV800TA = 22DAh and MBM29LV800BA = 225Bh for  $\times 16$  mode). These two bytes/words are given in "MBM29LV800TA/800BA Sector Protection Verify Autoselect Codes Table" and "Expanded Autoselect Code Table" ("■ DEVICE BUS OPERATION"). All identifiers for manufactures and device will exhibit odd parity with  $DQ_7$  defined as the parity bit. In order to read the proper device codes when executing the autoselect,  $A_1$  must be  $V_{IL}$ . (See "MBM29LV800TA/BA Sector Protection Verify Autoselect Codes Table" and "Expanded Autoselect Code Table" in "■ DEVICE BUS OPERATION".)

## 6. Write

Device erasure and programming are accomplished via the command register. The contents of the register serve as inputs to the internal state machine. The state machine outputs dictate the function of the device. The command register itself does not occupy any addressable memory location. The register is a latch used to store the commands, along with the address and data information needed to execute the command. The command register is written by bringing  $\overline{WE}$  to  $V_{IL}$ , while  $\overline{CE}$  is at  $V_{IL}$  and  $\overline{OE}$  is at  $V_{IH}$ . Addresses are latched on the falling edge of  $\overline{WE}$  or  $\overline{CE}$ , whichever happens later; while data is latched on the rising edge of  $\overline{WE}$  or  $\overline{CE}$ , whichever happens first. Standard microprocessor write timings are used.

Refer to AC Write Characteristics and the Erase/Programming Waveforms for specific timing parameters.

## 7. Sector Protection

The MBM29LV800TA/BA feature hardware sector protection. This feature will disable both program and erase operations in any number of sectors (0 through 18). The sector protection feature is enabled using programming equipment at the user's site. The devices are shipped with all sectors unprotected. Alternatively, Fujitsu may program and protect sectors in the factory prior to shipping the device.

To activate this mode, the programming equipment must force  $V_{ID}$  on address pin  $A_9$  and control pin  $\overline{OE}$ , (suggest  $V_{ID} = 11.5\text{ V}$ ),  $\overline{CE} = V_{IL}$ , and  $A_6 = V_{IL}$ . The sector addresses ( $A_{18}$ ,  $A_{17}$ ,  $A_{16}$ ,  $A_{15}$ ,  $A_{14}$ ,  $A_{13}$ , and  $A_{12}$ ) should be set to the sector to be protected. "Sector Address Tables (MBM29LV800TA)" and "Sector Address Tables (MBM29LV800BA)" in "■ FLEXIBLE SECTOR-ERASE ARCHITECTURE" define the sector address for each of the nineteen (19) individual sectors. Programming of the protection circuitry begins on the falling edge of the  $\overline{WE}$  pulse and is terminated with the rising edge of the same. Sector addresses must be held constant during the  $\overline{WE}$  pulse. See "13. AC Waveforms for Sector Protection Timing Diagram" in "■ SWITCHING WAVEFORMS" and "5. Sector Protection Algorithm" in "■ FLOW CHART" for sector protection waveforms and algorithm.

To verify programming of the protection circuitry, the programming equipment must force  $V_{ID}$  on address pin  $A_9$  with  $\overline{CE}$  and  $\overline{OE}$  at  $V_{IL}$  and  $\overline{WE}$  at  $V_{IH}$ . Scanning the sector addresses ( $A_{18}$ ,  $A_{17}$ ,  $A_{16}$ ,  $A_{15}$ ,  $A_{14}$ ,  $A_{13}$ , and  $A_{12}$ ) while ( $A_6$ ,  $A_1$ ,  $A_0$ ) = (0, 1, 0) will produce a logical "1" code at device output  $DQ_0$  for a protected sector. Otherwise the devices will read 00h for unprotected sector. In this mode, the lower order addresses, except for  $A_0$ ,  $A_1$ , and  $A_6$  are DON'T CARES. Address locations with  $A_1 = V_{IL}$  are reserved for Autoselect manufacturer and device codes.  $A_{-1}$  requires to apply to  $V_{IL}$  on byte mode.

It is also possible to determine if a sector is protected in the system by writing an Autoselect command. Performing a read operation at the address location XX02h, where the higher order addresses ( $A_{18}$ ,  $A_{17}$ ,  $A_{16}$ ,  $A_{15}$ ,  $A_{14}$ ,  $A_{13}$ , and  $A_{12}$ ) are the desired sector address will produce a logical "1" at  $DQ_0$  for a protected sector. See "MBM29LV800TA/800BA Sector Protection Verify Autoselect Codes Table" and "Expanded Autoselect Code Table" in "■ DEVICE BUS OPERATION" for Autoselect codes.

## 8. Temporary Sector Unprotection

This feature allows temporary unprotection of previously protected sectors of the MBM29LV800TA/BA devices in order to change data. The Sector Unprotection mode is activated by setting the  $\overline{\text{RESET}}$  pin to high voltage (12 V). During this mode, formerly protected sectors can be programmed or erased by selecting the sector addresses. Once the 12 V is taken away from the  $\overline{\text{RESET}}$  pin, all the previously protected sectors will be protected again. See “14. Temporary Sector Unprotection Timing Diagram” in “■SWITCHING WAVEFORMS” and “6. Temporary Sector Unprotection Algorithm” in “■FLOW CHART”.

## 9. $\overline{\text{RESET}}$

### Hardware Reset

The MBM29LV800TA/BA devices may be reset by driving the  $\overline{\text{RESET}}$  pin to  $V_{IL}$ . The  $\overline{\text{RESET}}$  pin has a pulse requirement and has to be kept low ( $V_{IL}$ ) for at least 500 ns in order to properly reset the internal state machine. Any operation in the process of being executed will be terminated and the internal state machine will be reset to the read mode 20  $\mu\text{s}$  after the  $\overline{\text{RESET}}$  pin is driven low. Furthermore, once the  $\overline{\text{RESET}}$  pin goes high, the devices require an additional  $t_{RH}$  before it will allow read access. When the  $\overline{\text{RESET}}$  pin is low, the devices will be in the standby mode for the duration of the pulse and all the data output pins will be tri-stated. If a hardware reset occurs during a program or erase operation, the data at that particular location will be corrupted. Please note that the  $\text{RY}/\overline{\text{BY}}$  output signal should be ignored during the  $\overline{\text{RESET}}$  pulse. See “9.  $\overline{\text{RESET}}/\text{RY}/\overline{\text{BY}}$  Timing Diagram” in “■SWITCHING WAVEFORMS” for the timing diagram. Refer to “8. Temporary Sector Unprotection” for additional functionality.

If hardware reset occurs during Embedded Erase Algorithm, there is a possibility that the erasing sector(s) cannot be used.

## ■ COMMAND DEFINITIONS

Device operations are selected by writing specific address and data sequences into the command register. Writing incorrect address and data values or writing them in the improper sequence will reset the devices to the read mode. “MBM29LV800TA/800BA Standard Command Definitions Table” in “■ DEVICE BUS OPERATION” defines the valid register command sequences. Note that the Erase Suspend (B0h) and Erase Resume (30h) commands are valid only while the Sector Erase operation is in progress. Moreover both Read/Reset commands are functionally equivalent, resetting the device to the read mode. Please note that commands are always written at DQ<sub>0</sub> to DQ<sub>7</sub> and DQ<sub>8</sub> to DQ<sub>15</sub> bits are ignored.

### 1. Read/Reset Command

In order to return from Autoselect mode or Exceeded Timing Limits (DQ<sub>5</sub> = 1) to read/reset mode, the read/reset operation is initiated by writing the Read/Reset command sequence into the command register. Microprocessor read cycles retrieve array data from the memory. The devices remain enabled for reads until the command register contents are altered.

The devices will automatically power-up in the read/reset state. In this case, a command sequence is not required to read data. Standard microprocessor read cycles will retrieve array data. This default value ensures that no spurious alteration of the memory content occurs during the power transition. Refer to the AC Read Characteristics and Waveforms for the specific timing parameters.

### 2. Autoselect Command

Flash memories are intended for use in applications where the local CPU alters memory contents. As such, manufacture and device codes must be accessible while the devices reside in the target system. PROM programmers typically access the signature codes by raising A<sub>9</sub> to a high voltage. However, multiplexing high voltage onto the address lines is not generally desired system design practice.

The device contains an Autoselect command operation to supplement traditional PROM programming methodology. The operation is initiated by writing the Autoselect command sequence into the command register. Following the command write, a read cycle from address XX00h retrieves the manufacture code of 04h. A read cycle from address XX01h for ×16(XX02h for ×8) returns the device code (MBM29LV800TA = DAh and MBM29LV800BA = 5Bh for ×8 mode; MBM29LV800TA = 22DAh and MBM29LV800BA = 225Bh for ×16 mode). (See “MBM29LV800TA/800BA Sector Protection Verify Autoselect Codes Table” and “Expanded Autoselect Code Table” in “■ DEVICE BUS OPERATION”.) All manufacturer and device codes will exhibit odd parity with DQ<sub>7</sub> defined as the parity bit. Sector state (protection or unprotection) will be informed by address XX02h for ×16 (XX04h for ×8).

Scanning the sector addresses (A<sub>18</sub>, A<sub>17</sub>, A<sub>16</sub>, A<sub>15</sub>, A<sub>14</sub>, A<sub>13</sub>, and A<sub>12</sub>) while (A<sub>6</sub>, A<sub>1</sub>, A<sub>0</sub>) = (0, 1, 0) will produce a logical “1” at device output DQ<sub>0</sub> for a protected sector. The programming verification should be performed in margin mode on the protected sector. (See “MBM29LV800TA/BA User Bus Operations Tables (BYTE = V<sub>IH</sub> and BYTE = V<sub>IL</sub>)” in “■ DEVICE BUS OPERATION”.)

To terminate the operation, it is necessary to write the Read/Reset command sequence into the register, and also to write the Autoselect command during the operation, execute it after writing Read/Reset command sequence.

### 3. Byte/Word Programming

The devices are programmed on a byte-by-byte (or word-by-word) basis. Programming is a four bus cycle operation. There are two “unlock” write cycles. These are followed by the program set-up command and data write cycles. Addresses are latched on the falling edge of  $\overline{CE}$  or  $\overline{WE}$ , whichever happens later and the data is latched on the rising edge of  $\overline{CE}$  or  $\overline{WE}$ , whichever happens first. The rising edge of  $\overline{CE}$  or  $\overline{WE}$  (whichever happens first) begins programming. Upon executing the Embedded Program Algorithm command sequence, the system is not required to provide further controls or timings. The device will automatically provide adequate internally generated program pulses and verify the programmed cell margin.

The automatic programming operation is completed when the data on DQ<sub>7</sub> is equivalent to data written to this bit at which time the devices return to the read mode and addresses are no longer latched. (See “Hardware Sequence Flags Table”.) Therefore, the devices require that a valid address to the devices be supplied by the system at this particular instance of time. Hence,  $\overline{Data}$  Polling must be performed at the memory location which is being programmed.

Any commands written to the chip during this period will be ignored. If hardware reset occurs during the programming operation, it is impossible to guarantee the data are being written.

Programming is allowed in any sequence and across sector boundaries. Beware that a data “0” cannot be programmed back to a “1”. Attempting to do so may either hang up the device or result in an apparent success according to the data polling algorithm but a read from read/reset mode will show that the data is still “0”. Only erase operations can convert “0”s to “1”s.

“1. Embedded Program™ Algorithm” in “■FLOW CHART” illustrates the Embedded Program™ Algorithm using typical command strings and bus operations.

### 4. Chip Erase

Chip erase is a six bus cycle operation. There are two “unlock” write cycles. These are followed by writing the “set-up” command. Two more “unlock” write cycles are then followed by the chip erase command.

Chip erase does not require the user to program the device prior to erase. Upon executing the Embedded Erase Algorithm command sequence the devices will automatically program and verify the entire memory for an all zero data pattern prior to electrical erase (Preprogram function). The system is not required to provide any controls or timings during these operations.

The automatic erase begins on the rising edge of the last  $\overline{WE}$  pulse in the command sequence and terminates when the data on DQ<sub>7</sub> is “1” (See “8. Write Operation Status”.) at which time the device returns to read the mode.

Chip Erase Time; Sector Erase Time × All sectors + Chip Program Time (Preprogramming)

“2. Embedded Erase™ Algorithm” in “■FLOW CHART” illustrates the Embedded Erase™ Algorithm using typical command strings and bus operations.

### 5. Sector Erase

Sector erase is a six bus cycle operation. There are two “unlock” write cycles. These are followed by writing the “set-up” command. Two more “unlock” write cycles are then followed by the Sector Erase command. The sector address (any address location within the desired sector) is latched on the falling edge of  $\overline{WE}$ , while the command (Data=30h) is latched on the rising edge of  $\overline{WE}$ . After time-out of 50 μs from the rising edge of the last sector erase command, the sector erase operation will begin.

Multiple sectors may be erased concurrently by writing the six bus cycle operations on “MBM29LV800TA/800BA Standard Command Definitions Table” in “■ DEVICE BUS OPERATION”. This sequence is followed with writes of the Sector Erase command to addresses in other sectors desired to be concurrently erased. The time between writes must be less than 50 μs otherwise that command will not be accepted and erasure will start. It is recommended that processor interrupts be disabled during this time to guarantee this condition. The interrupts can be re-enabled after the last Sector Erase command is written. A time-out of 50 μs from the rising edge of the last  $\overline{WE}$  will initiate the execution of the Sector Erase command(s). If another falling edge of the  $\overline{WE}$  occurs

within the 50  $\mu$ s time-out window the timer is reset. (Monitor DQ<sub>3</sub> to determine if the sector erase timer window is still open, see “12. DQ<sub>3</sub>”, Sector Erase Timer.) Any command other than Sector Erase or Erase Suspend during this time-out period will reset the devices to the read mode, ignoring the previous command string. Resetting the devices once execution has begun will corrupt the data in the sector. In that case, restart the erase on those sectors and allow them to complete. (Refer to “8. Write Operation Status” for Sector Erase Timer operation.) Loading the sector erase buffer may be done in any sequence and with any number of sectors (0 to 18). Sector erase does not require the user to program the devices prior to erase. The devices automatically program all memory locations in the sector(s) to be erased prior to electrical erase (Preprogram function). When erasing a sector or sectors the remaining unselected sectors are not affected. The system is not required to provide any controls or timings during these operations.

The automatic sector erase begins after the 50  $\mu$ s time out from the rising edge of the  $\overline{WE}$  pulse for the last sector erase command pulse and terminates when the data on DQ<sub>7</sub> is “1” (See “8. Write Operation Status”.) at which time the devices return to the read mode.  $\overline{Data}$  polling must be performed at an address within any of the sectors being erased. Multiple Sector Erase Time; [Sector Erase Time + Sector Program Time (Preprogramming)]  $\times$  Number of Sector Erase

“2. Embedded Erase™ Algorithm” in “■FLOW CHART” illustrates the Embedded Erase™ Algorithm using typical command strings and bus operations.

## 6. Erase Suspend

The Erase Suspend command allows the user to interrupt a Sector Erase operation and then perform data reads from or programs to a sector not being erased. This command is applicable ONLY during the Sector Erase operation which includes the time-out period for sector erase. The Erase Suspend command will be ignored if written during the Chip Erase operation or Embedded Program Algorithm. Writing the Erase Suspend command during the Sector Erase time-out results in immediate termination of the time-out period and suspension of the erase operation.

Writing the Erase Resume command resumes the erase operation. The addresses are DON'T CARES when writing the Erase Suspend or Erase Resume command.

When the Erase Suspend command is written during the Sector Erase operation, the device will take a maximum of 20  $\mu$ s to suspend the erase operation. When the devices have entered the erase-suspended mode, the RY/ $\overline{BY}$  output pin and the DQ<sub>7</sub> bit will be at logic “1”, and DQ<sub>6</sub> will stop toggling. The user must use the address of the erasing sector for reading DQ<sub>6</sub> and DQ<sub>7</sub> to determine if the erase operation has been suspended. Further writes of the Erase Suspend command are ignored.

When the erase operation has been suspended, the devices default to the erase-suspend-read mode. Reading data in this mode is the same as reading from the standard read mode except that the data must be read from sectors that have not been erase-suspended. Successively reading from the erase-suspended sector while the device is in the erase-suspend-read mode will cause DQ<sub>2</sub> to toggle. (See “13. DQ<sub>2</sub>”.)

After entering the erase-suspend-read mode, the user can program the device by writing the appropriate command sequence for Program. This program mode is known as the erase-suspend-program mode. Again, programming in this mode is the same as programming in the regular Program mode except that the data must be programmed to sectors that are not erase-suspended. Successively reading from the erase-suspended sector while the devices are in the erase-suspend-program mode will cause DQ<sub>2</sub> to toggle. The end of the erase-suspended Program operation is detected by the RY/ $\overline{BY}$  output pin,  $\overline{Data}$  polling of DQ<sub>7</sub>, or by the Toggle Bit I (DQ<sub>6</sub>) which is the same as the regular Program operation. Note that DQ<sub>7</sub> must be read from the Program address while DQ<sub>6</sub> can be read from any address.

To resume the operation of Sector Erase, the Resume command (30h) should be written. Any further writes of the Resume command at this point will be ignored. Another Erase Suspend command can be written after the chip has resumed erasing.

## 7. Extended Command

### (1) Fast Mode

MBM29LV800TA/BA has Fast Mode function. This mode dispenses with the initial two unlock cycles required in the standard program command sequence by writing Fast Mode command into the command register. In this mode, the required bus cycle for programming is two cycles instead of four bus cycles in standard program command. (Do not write erase command in this mode.) The read operation is also executed after exiting this mode. To exit this mode, it is necessary to write Fast Mode Reset command into the command register. (Refer to “8. Embedded Program™ Algorithm for Fast Mode” in “■FLOW CHART” Extended algorithm.) The  $V_{CC}$  active current is required even  $\overline{CE} = V_{IH}$  during Fast Mode.

### (2) Fast Programming

During Fast Mode, the programming can be executed with two bus cycles operation. The Embedded Program Algorithm is executed by writing program set-up command (A0h) and data write cycles (PA/PD). (Refer to “8. Embedded Program™ Algorithm for Fast Mode” in “■FLOW CHART” Extended algorithm.)

### (3) Extended Sector Protection

In addition to normal sector protection, the MBM29LV800TA/BA has Extended Sector Protection as extended function. This function enable to protect sector by forcing  $V_{ID}$  on  $\overline{RESET}$  pin and write a commnad sequence. Unlike conventional procedure, it is not necessary to force  $V_{ID}$  and control timing for control pins. The only  $\overline{RESET}$  pin requires  $V_{ID}$  for sector protection in this mode. The extended sector protect requires  $V_{ID}$  on  $\overline{RESET}$  pin. With this condition, the operation is initiated by writing the set-up command (60h) into the command register. Then, the sector addresses pins ( $A_{18}, A_{17}, A_{16}, A_{15}, A_{14}, A_{13}$  and  $A_{12}$ ) and ( $A_6, A_1, A_0$ ) = (0, 1, 0) should be set to the sector to be protected (recommend to set  $V_{IL}$  for the other addresses pins), and write extended sector protect command (60h). A sector is typically protected in 150  $\mu s$ . To verify programming of the protection circuitry, the sector addresses pins ( $A_{18}, A_{17}, A_{16}, A_{15}, A_{14}, A_{13}$  and  $A_{12}$ ) and ( $A_6, A_1, A_0$ ) = (0, 1, 0) should be set and write a command (40h). Following the command write, a logical “1” at device output  $DQ_0$  will produce for protected sector in the read operation. If the output data is logical “0”, please repeat to write extended sector protect command (60h) again. To terminate the operation, it is necessary to set  $\overline{RESET}$  pin to  $V_{IH}$ .

## 8. Write Operation Status

**Hardware Sequence Flags Table**

Status		$DQ_7$	$DQ_6$	$DQ_5$	$DQ_3$	$DQ_2$	
In Progress	Embedded Program Algorithm	$\overline{DQ}_7$	Toggle	0	0	1	
	Embedded Erase Algorithm	0	Toggle	0	1	Toggle	
	Erase Suspended Mode	Erase Suspend Read (Erase Suspended Sector)	1	1	0	0	Toggle
		Erase Suspend Read (Non-Erase Suspended Sector)	Data	Data	Data	Data	Data
	Erase Suspend Program (Non-Erase Suspended Sector)	$\overline{DQ}_7$	Toggle *1	0	0	1 *2	
Exceeded Time Limits	Embedded Program Algorithm	$\overline{DQ}_7$	Toggle	1	0	1	
	Embedded Erase Algorithm	0	Toggle	1	1	N/A	
	Erase Suspended Mode	Erase Suspend Program (Non-Erase Suspended Sector)	$\overline{DQ}_7$	Toggle	1	0	N/A

\*1: Performing successive read operations from any address will cause  $DQ_6$  to toggle.

\*2: Reading the byte address being programmed while in the erase-suspend program mode will indicate logic “1” at the  $DQ_2$  bit. However, successive reads from the erase-suspended sector will cause  $DQ_2$  to toggle.

Notes: •  $DQ_0$  and  $DQ_1$  are reserve pins for future use.  
 •  $DQ_4$  is Fujitsu internal use only.

## 9. DQ<sub>7</sub>

### Data Polling

The MBM29LV800TA/BA devices feature  $\overline{\text{Data}}$  Polling as a method to indicate to the host that the Embedded Algorithms are in progress or completed. During the Embedded Program Algorithm an attempt to read the devices will produce the complement of the data last written to DQ<sub>7</sub>. Upon completion of the Embedded Program Algorithm, an attempt to read the device will produce the true data last written to DQ<sub>7</sub>. During the Embedded Erase Algorithm, an attempt to read the device will produce a “0” at the DQ<sub>7</sub> output. Upon completion of the Embedded Erase Algorithm an attempt to read the device will produce a “1” at the DQ<sub>7</sub> output. The flowchart for  $\overline{\text{Data}}$  Polling (DQ<sub>7</sub>) is shown in “3.  $\overline{\text{Data}}$  Polling Algorithm” (“■FLOW CHART”).

For chip erase and sector erase, the  $\overline{\text{Data}}$  Polling is valid after the rising edge of the sixth  $\overline{\text{WE}}$  pulse in the six write pulse sequence.  $\overline{\text{Data}}$  Polling must be performed at sector address within any of the sectors being erased and not a protected sector. Otherwise, the status may not be valid. Once the Embedded Algorithm operation is close to being completed, the MBM29LV800TA/BA data pins (DQ<sub>7</sub>) may change asynchronously while the output enable ( $\overline{\text{OE}}$ ) is asserted low. This means that the devices are driving status information on DQ<sub>7</sub> at one instant of time and then that byte's valid data at the next instant of time. Depending on when the system samples the DQ<sub>7</sub> output, it may read the status or valid data. Even if the device has completed the Embedded Algorithm operation and DQ<sub>7</sub> has a valid data, the data outputs on DQ<sub>0</sub> to DQ<sub>6</sub> may be still invalid. The valid data on DQ<sub>0</sub> to DQ<sub>7</sub> will be read on the successive read attempts.

The  $\overline{\text{Data}}$  Polling feature is only active during the Embedded Programming Algorithm, Embedded Erase Algorithm or sector erase time-out. (See “Hardware Sequence Flags Table”.)

See “6. AC Waveforms for  $\overline{\text{Data}}$  Polling during Embedded Algorithm Operations” in “■SWITCHING WAVEFORMS” for the  $\overline{\text{Data}}$  Polling timing specifications and diagrams.

## 10. DQ<sub>6</sub>

### Toggle Bit I

The MBM29LV800TA/BA also feature the “Toggle Bit I” as a method to indicate to the host system that the Embedded Algorithms are in progress or completed.

During an Embedded Program or Erase Algorithm cycle, successive attempts to read ( $\overline{\text{OE}}$  toggling) data from the devices will result in DQ<sub>6</sub> toggling between one and zero. Once the Embedded Program or Erase Algorithm cycle is completed, DQ<sub>6</sub> will stop toggling and valid data will be read on the next successive attempts. During programming, the Toggle Bit I is valid after the rising edge of the fourth  $\overline{\text{WE}}$  pulse in the four write pulse sequence. For chip erase and sector erase, the Toggle Bit I is valid after the rising edge of the sixth  $\overline{\text{WE}}$  pulse in the six write pulse sequence. The Toggle Bit I is active during the sector time out.

In programming, if the sector being written to is protected, the toggle bit will toggle for about 2  $\mu\text{s}$  and then stop toggling without the data having changed. In erase, the devices will erase all the selected sectors except for the ones that are protected. If all selected sectors are protected, the chip will toggle the toggle bit for about 100  $\mu\text{s}$  and then drop back into read mode, having changed none of the data.

Either  $\overline{\text{CE}}$  or  $\overline{\text{OE}}$  toggling will cause the DQ<sub>6</sub> to toggle. In addition, an Erase Suspend/Resume command will cause the DQ<sub>6</sub> to toggle.

See “7. AC Waveforms for Toggle Bit I during Embedded Algorithm Operations” in “■SWITCHING WAVEFORMS” for the Toggle Bit I timing specifications and diagrams.

## 11. DQ<sub>5</sub>

### Exceeded Timing Limits

DQ<sub>5</sub> will indicate if the program or erase time has exceeded the specified limits (internal pulse count). Under these conditions DQ<sub>5</sub> will produce a “1”. This is a failure condition which indicates that the program or erase cycle was not successfully completed.  $\overline{\text{Data}}$  Polling is the only operating function of the devices under this condition. The  $\overline{\text{CE}}$  circuit will partially power down the device under these conditions (to approximately 2 mA).

The  $\overline{OE}$  and  $\overline{WE}$  pins will control the output disable functions as described in “MBM29LV800TA/BA User Bus Operations Tables ( $\overline{BYTE} = V_{IH}$  and  $\overline{BYTE} = V_{IL}$ )” in “■ DEVICE BUS OPERATION”.

The DQ<sub>5</sub> failure condition may also appear if a user tries to program a non blank location without erasing. In this case the devices lock out and never complete the Embedded Algorithm operation. Hence, the system never reads a valid data on DQ<sub>7</sub> bit and DQ<sub>6</sub> never stops toggling. Once the devices have exceeded timing limits, the DQ<sub>5</sub> bit will indicate a “1.” Please note that this is not a device failure condition since the devices were incorrectly used. If this occurs, reset the device with command sequence.

## 12. DQ<sub>3</sub>

### Sector Erase Timer

After the completion of the initial sector erase command sequence the sector erase time-out will begin. DQ<sub>3</sub> will remain low until the time-out is complete.  $\overline{Data}$  Polling and Toggle Bit are valid after the initial sector erase command sequence.

If  $\overline{Data}$  Polling or the Toggle Bit I indicates the device has been written with a valid erase command, DQ<sub>3</sub> may be used to determine if the sector erase timer window is still open. If DQ<sub>3</sub> is high (“1”) the internally controlled erase cycle has begun; attempts to write subsequent commands to the device will be ignored until the erase operation is completed as indicated by  $\overline{Data}$  Polling or Toggle Bit I. If DQ<sub>3</sub> is low (“0”), the device will accept additional sector erase commands. To insure the command has been accepted, the system software should check the status of DQ<sub>3</sub> prior to and following each subsequent Sector Erase command. If DQ<sub>3</sub> were high on the second status check, the command may not have been accepted.

See “Hardware Sequence Flags Table”.

## 13. DQ<sub>2</sub>

### Toggle Bit II

This toggle bit II, along with DQ<sub>6</sub>, can be used to determine whether the devices are in the Embedded Erase Algorithm or in Erase Suspend.

Successive reads from the erasing sector will cause DQ<sub>2</sub> to toggle during the Embedded Erase Algorithm. If the devices are in the erase-suspended-read mode, successive reads from the erase-suspended sector will cause DQ<sub>2</sub> to toggle. When the devices are in the erase-suspended-program mode, successive reads from the byte address of the non-erase suspended sector will indicate a logic “1” at the DQ<sub>2</sub> bit.

DQ<sub>6</sub> is different from DQ<sub>2</sub> in that DQ<sub>6</sub> toggles only when the standard program or Erase, or Erase Suspend Program operation is in progress. The behavior of these two status bits, along with that of DQ<sub>7</sub>, is summarized as follows:

For example, DQ<sub>2</sub> and DQ<sub>6</sub> can be used together to determine if the erase-suspend-read mode is in progress. (DQ<sub>2</sub> toggles while DQ<sub>6</sub> does not.) See also “Hardware Sequence Flags Table” and “15. DQ<sub>2</sub> vs. DQ<sub>6</sub>” in “■ SWITCHING WAVEFORMS”.

Furthermore, DQ<sub>2</sub> can also be used to determine which sector is being erased. When the device is in the erase mode, DQ<sub>2</sub> toggles if this bit is read from an erasing sector.

Mode	DQ <sub>7</sub>	DQ <sub>6</sub>	DQ <sub>2</sub>
Program	$\overline{DQ_7}$	Toggle	1
Erase	0	Toggle	Toggle
Erase-Suspend Read (Erase-Suspended Sector) *1	1	1	Toggle
Erase-Suspend Program	$\overline{DQ_7}$	Toggle *1	1 *2

\*1: Performing successive read operations from any address will cause DQ<sub>6</sub> to toggle.

\*2: Reading the byte address being programmed while in the erase-suspend program mode will indicate logic “1” at the DQ<sub>2</sub> bit. However, successive reads from the erase-suspended sector will cause DQ<sub>2</sub> to toggle.

## 14. RY/ $\overline{\text{BY}}$

### Ready/Busy

The MBM29LV800TA/BA provide a RY/ $\overline{\text{BY}}$  open-drain output pin as a way to indicate to the host system that the Embedded Algorithms are either in progress or has been completed. If the output is low, the devices are busy with either a program or erase operation. If the output is high, the devices are ready to accept any read/write or erase operation. When the RY/ $\overline{\text{BY}}$  pin is low, the devices will not accept any additional program or erase commands. If the MBM29LV800TA/BA are placed in an Erase Suspend mode, the RY/ $\overline{\text{BY}}$  output will be high. During programming, the RY/ $\overline{\text{BY}}$  pin is driven low after the rising edge of the fourth  $\overline{\text{WE}}$  pulse. During an erase operation, the RY/ $\overline{\text{BY}}$  pin is driven low after the rising edge of the sixth  $\overline{\text{WE}}$  pulse. The RY/ $\overline{\text{BY}}$  pin will indicate a busy condition during the  $\overline{\text{RESET}}$  pulse. Refer to “8. RY/ $\overline{\text{BY}}$  Timing Diagram during Program/Erase Operations” and “9.  $\overline{\text{RESET}}$ /RY/ $\overline{\text{BY}}$  Timing Diagram” in “■SWITCHING WAVEFORMS” for a detailed timing diagram. The RY/ $\overline{\text{BY}}$  pin is pulled high in standby mode.

Since this is an open-drain output, RY/ $\overline{\text{BY}}$  pins can be tied together in parallel with a pull-up resistor to  $V_{\text{CC}}$ .

## 15. Byte/Word Configuration

The  $\overline{\text{BYTE}}$  pin selects the byte (8-bit) mode or word (16-bit) mode for the MBM29LV800TA/BA devices. When this pin is driven high, the devices operate in the word (16-bit) mode. The data is read and programmed at DQ<sub>0</sub> to DQ<sub>15</sub>. When this pin is driven low, the devices operate in byte (8-bit) mode. Under this mode, the DQ<sub>15/A-1</sub> pin becomes the lowest address bit and DQ<sub>8</sub> to DQ<sub>14</sub> bits are tri-stated. However, the command bus cycle is always an 8-bit operation and hence commands are written at DQ<sub>0</sub> to DQ<sub>7</sub> and the DQ<sub>8</sub> to DQ<sub>15</sub> bits are ignored. Refer to “10. Timing Diagram for Word Mode Configuration”, “11. Timing Diagram for Byte Mode Configuration” and “12.  $\overline{\text{BYTE}}$  Timing Diagram for Write Operations” in “■SWITCHING WAVEFORMS” for the timing diagram.

## 16. Data Protection

The MBM29LV800TA/BA are designed to offer protection against accidental erasure or programming caused by spurious system level signals that may exist during power transitions. During power up the devices automatically reset the internal state machine in the Read mode. Also, with its control register architecture, alteration of the memory contents only occurs after successful completion of specific multi-bus cycle command sequences.

The devices also incorporate several features to prevent inadvertent write cycles resulting from  $V_{\text{CC}}$  power-up and power-down transitions or system noise.

## 17. Low $V_{\text{CC}}$ Write Inhibit

To avoid initiation of a write cycle during  $V_{\text{CC}}$  power-up and power-down, a write cycle is locked out for  $V_{\text{CC}}$  less than 2.3 V (typically 2.4 V). If  $V_{\text{CC}} < V_{\text{LKO}}$ , the command register is disabled and all internal program/erase circuits are disabled. Under this condition the device will reset to the read mode. Subsequent writes will be ignored until the  $V_{\text{CC}}$  level is greater than  $V_{\text{LKO}}$ . It is the users responsibility to ensure that the control pins are logically correct to prevent unintentional writes when  $V_{\text{CC}}$  is above 2.3 V.

If Embedded Erase Algorithm is interrupted, there is possibility that the erasing sector(s) cannot be used.

## 18. Write Pulse “Glitch” Protection

Noise pulses of less than 3 ns (typical) on  $\overline{\text{OE}}$ ,  $\overline{\text{CE}}$ , or  $\overline{\text{WE}}$  will not initiate a write cycle.

## 19. Logical Inhibit

Writing is inhibited by holding any one of  $\overline{\text{OE}} = V_{\text{IL}}$ ,  $\overline{\text{CE}} = V_{\text{IH}}$ , or  $\overline{\text{WE}} = V_{\text{IH}}$ . To initiate a write cycle  $\overline{\text{CE}}$  and  $\overline{\text{WE}}$  must be a logical zero while  $\overline{\text{OE}}$  is a logical one.

## 20. Power-Up Write Inhibit

Power-up of the devices with  $\overline{\text{WE}} = \overline{\text{CE}} = V_{\text{IL}}$  and  $\overline{\text{OE}} = V_{\text{IH}}$  will not accept commands on the rising edge of  $\overline{\text{WE}}$ . The internal state machine is automatically reset to the read mode on power-up.

# MBM29LV800TA-70/-90/MBM29LV800BA-70/-90

## ■ ABSOLUTE MAXIMUM RATINGS

Parameter	Symbol	Rating		Unit
		Min	Max	
Storage Temperature	$T_{stg}$	-55	+125	°C
Ambient Temperature with Power Applied	$T_A$	-40	+85	°C
Voltage with respect to Ground All pins except $A_9$ , $\overline{OE}$ , $\overline{RESET}$ *1,*2	$V_{IN}, V_{OUT}$	-0.5	$V_{CC}+0.5$	V
Power Supply Voltage*1	$V_{CC}$	-0.5	+5.5	V
$A_9$ , $\overline{OE}$ , and $\overline{RESET}$ *1,*3	$V_{IN}$	-0.5	+13.0	V

\*1 : Voltage is defined on the basis of  $V_{SS} = GND = 0$  V.

\*2 : Minimum DC voltage on input or I/O pins is -0.5 V. During voltage transitions, input or I/O pins may undershoot  $V_{SS}$  to -2.0 V for periods of up to 20 ns. Maximum DC voltage on input or I/O pins is  $V_{CC} + 0.5$  V. During voltage transitions, input or I/O pins may overshoot to  $V_{CC} + 2.0$  V for periods of up to 20 ns.

\*3 : Minimum DC input voltage on  $A_9$ ,  $\overline{OE}$  and  $\overline{RESET}$  pins is -0.5 V. During voltage transitions,  $A_9$ ,  $\overline{OE}$  and  $\overline{RESET}$  pins may undershoot  $V_{SS}$  to -2.0 V for periods of up to 20 ns. Voltage difference between input and supply voltage ( $V_{IN} - V_{CC}$ ) does not exceed +9.0 V. Maximum DC input voltage on  $A_9$ ,  $\overline{OE}$  and  $\overline{RESET}$  pins is +13.0 V which may overshoot to +14.0 V for periods of up to 20 ns.

WARNING: Semiconductor devices can be permanently damaged by application of stress (voltage, current, temperature, etc.) in excess of absolute maximum ratings. Do not exceed these ratings.

## ■ RECOMMENDED OPERATING RANGES

Parameter	Symbol	Conditions	Value		Unit
			Min	Max	
Ambient Temperature	$T_A$	—	-40	+85	°C
Power Supply Voltage*	$V_{CC}$	MBM29LV800TA/BA-70	+3.0	+3.6	V
		MBM29LV800TA/BA-90	+2.7	+3.6	V

\* : Voltage is defined on the basis of  $V_{SS} = GND = 0$  V.

Note: Operating ranges define those limits between which the functionality of the devices are guaranteed.

WARNING: The recommended operating conditions are required in order to ensure the normal operation of the semiconductor device. All of the device's electrical characteristics are warranted when the device is operated within these ranges.

Always use semiconductor devices within their recommended operating condition ranges. Operation outside these ranges may adversely affect reliability and could result in device failure.

No warranty is made with respect to uses, operating conditions, or combinations not represented on the data sheet. Users considering application outside the listed conditions are advised to contact their FUJITSU representatives beforehand.

## ■ MAXIMUM OVERSHOOT /MAXIMUM UNDERSHOOT

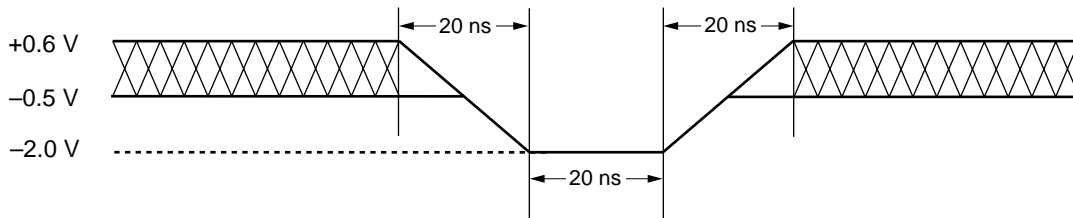

Figure 1 Maximum Undershoot Waveform

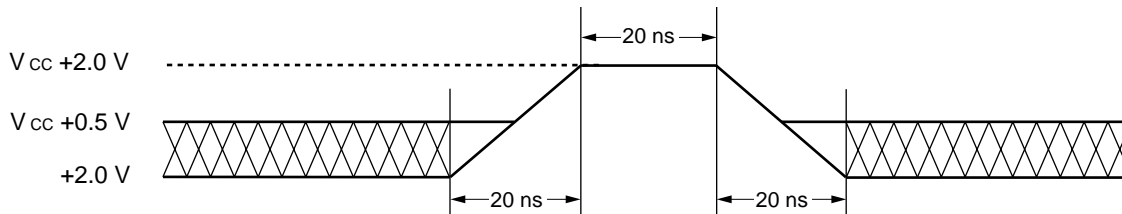
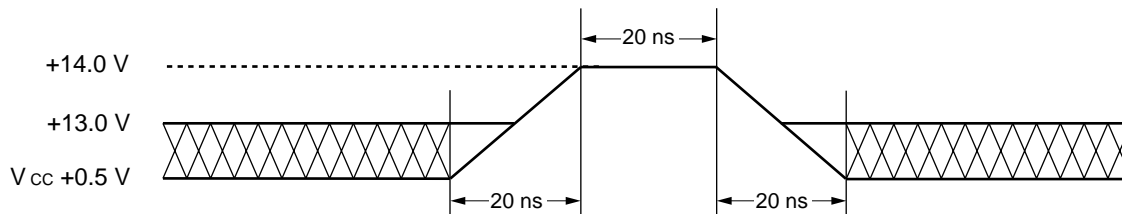

Figure 2 Maximum Overshoot Waveform 1



\*: This waveform is applied for  $A_9$ ,  $\overline{OE}$ , and  $\overline{RESET}$ .

Figure 3 Maximum Overshoot Waveform 2

# MBM29LV800TA-70/-90/MBM29LV800BA-70/-90

## ■ DC CHARACTERISTICS

Parameter	Symbol	Test Conditions	Value		Unit	
			Min	Max		
Input Leakage Current	$I_{LI}$	$V_{IN} = V_{SS} \text{ to } V_{CC}, V_{CC} = V_{CC} \text{ Max}$	-1.0	+1.0	$\mu\text{A}$	
Output Leakage Current	$I_{LO}$	$V_{OUT} = V_{SS} \text{ to } V_{CC}, V_{CC} = V_{CC} \text{ Max}$	-1.0	+1.0	$\mu\text{A}$	
$A_9, \overline{OE}, \overline{RESET}$ Inputs Leakage Current	$I_{LIT}$	$V_{CC} = V_{CC} \text{ Max}$ $A_9, \overline{OE}, \overline{RESET} = 12.5 \text{ V}$	—	35	$\mu\text{A}$	
V <sub>CC</sub> Active Current *1	$I_{CC1}$	$\overline{CE} = V_{IL}, \overline{OE} = V_{IH},$ $f=10 \text{ MHz}$	Byte	—	22	mA
			Word	—	25	
		$\overline{CE} = V_{IL}, \overline{OE} = V_{IH},$ $f=5 \text{ MHz}$	Byte	—	12	mA
			Word	—	15	
V <sub>CC</sub> Active Current *2	$I_{CC2}$	$\overline{CE} = V_{IL}, \overline{OE} = V_{IH}$	—	35	mA	
V <sub>CC</sub> Current (Standby)	$I_{CC3}$	$V_{CC} = V_{CC} \text{ Max}, \overline{CE} = V_{CC} \pm 0.3 \text{ V},$ $\overline{RESET} = V_{CC} \pm 0.3 \text{ V}$	—	5	$\mu\text{A}$	
V <sub>CC</sub> Current (Standby, Reset)	$I_{CC4}$	$V_{CC} = V_{CC} \text{ Max},$ $\overline{RESET} = V_{SS} \pm 0.3 \text{ V}$	—	5	$\mu\text{A}$	
V <sub>CC</sub> Current (Automatic Sleep Mode) *3	$I_{CC5}$	$V_{CC} = V_{CC} \text{ Max}, \overline{CE} = V_{SS} \pm 0.3 \text{ V},$ $\overline{RESET} = V_{CC} \pm 0.3 \text{ V}$ $V_{IN} = V_{CC} \pm 0.3 \text{ V or } V_{SS} \pm 0.3 \text{ V}$	—	5	$\mu\text{A}$	
Input Low Level	$V_{IL}$	—	-0.5	0.6	V	
Input High Level	$V_{IH}$	—	2.0	$V_{CC}+0.3$	V	
Voltage for Autoselect and Sector Protection ( $A_9, \overline{OE}, \overline{RESET}$ ) *4	$V_{ID}$	—	11.5	12.5	V	
Output Low Voltage Level	$V_{OL}$	$I_{OL} = 4.0 \text{ mA}, V_{CC} = V_{CC} \text{ Min}$	—	0.45	V	
Output High Voltage Level	$V_{OH1}$	$I_{OH} = -2.0 \text{ mA}, V_{CC} = V_{CC} \text{ Min}$	2.4	—	V	
	$V_{OH2}$	$I_{OH} = -100 \mu\text{A}$	$V_{CC}-0.4$	—	V	
Low V <sub>CC</sub> Lock-Out Voltage	$V_{LKO}$	—	2.3	2.5	V	

\*1: The  $I_{CC}$  current listed includes both the DC operating current and the frequency dependent component (at 10 MHz).

\*2:  $I_{CC}$  active while Embedded Algorithm (program or erase) is in progress.

\*3: Automatic sleep mode enables the low power mode when address remain stable for 150 ns.

\*4: ( $V_{ID} - V_{CC}$ ) do not exceed 9 V.

# MBM29LV800TA-70/-90/MBM29LV800BA-70/-90

## AC CHARACTERISTICS

### Read Only Operations Characteristics

Parameter	Symbol		Test Setup	Value *				Unit
	JEDEC	Standard		-70		-90		
				Min	Max	Min	Max	
Read Cycle Time	$t_{AVAV}$	$t_{RC}$	—	70	—	90	—	ns
Address to Output Delay	$t_{AVQV}$	$t_{ACC}$	$\overline{CE} = V_{IL}$ $\overline{OE} = V_{IL}$	—	70	—	90	ns
Chip Enable to Output Delay	$t_{ELQV}$	$t_{CE}$	$\overline{OE} = V_{IL}$	—	70	—	90	ns
Output Enable to Output Delay	$t_{GLQV}$	$t_{OE}$	—	—	30	—	35	ns
Chip Enable to Output High-Z	$t_{EHQZ}$	$t_{DF}$	—	—	25	—	30	ns
Output Enable to Output High-Z	$t_{GHQZ}$	$t_{DF}$	—	—	25	—	30	ns
Output Hold Time From Addresses, $\overline{CE}$ or $\overline{OE}$ , Whichever Occurs First	$t_{AXQX}$	$t_{OH}$	—	0	—	0	—	ns
$\overline{RESET}$ Pin Low to Read Mode	—	$t_{READY}$	—	—	20	—	20	$\mu s$
$\overline{CE}$ to $\overline{BYTE}$ Switching Low or High	—	$t_{ELFL}$ $t_{ELFH}$	—	—	5	—	5	ns

**Note:** Test Conditions:  
 Output Load: 1 TTL gate and 30 pF (MBM29LV800TA/BA-70)  
 1 TTL gate and 100 pF (MBM29LV800TA/BA-90)  
 Input rise and fall times: 5 ns  
 Input pulse levels: 0.0 V or 3.0 V  
 Timing measurement reference level  
 Input: 1.5 V  
 Output: 1.5 V

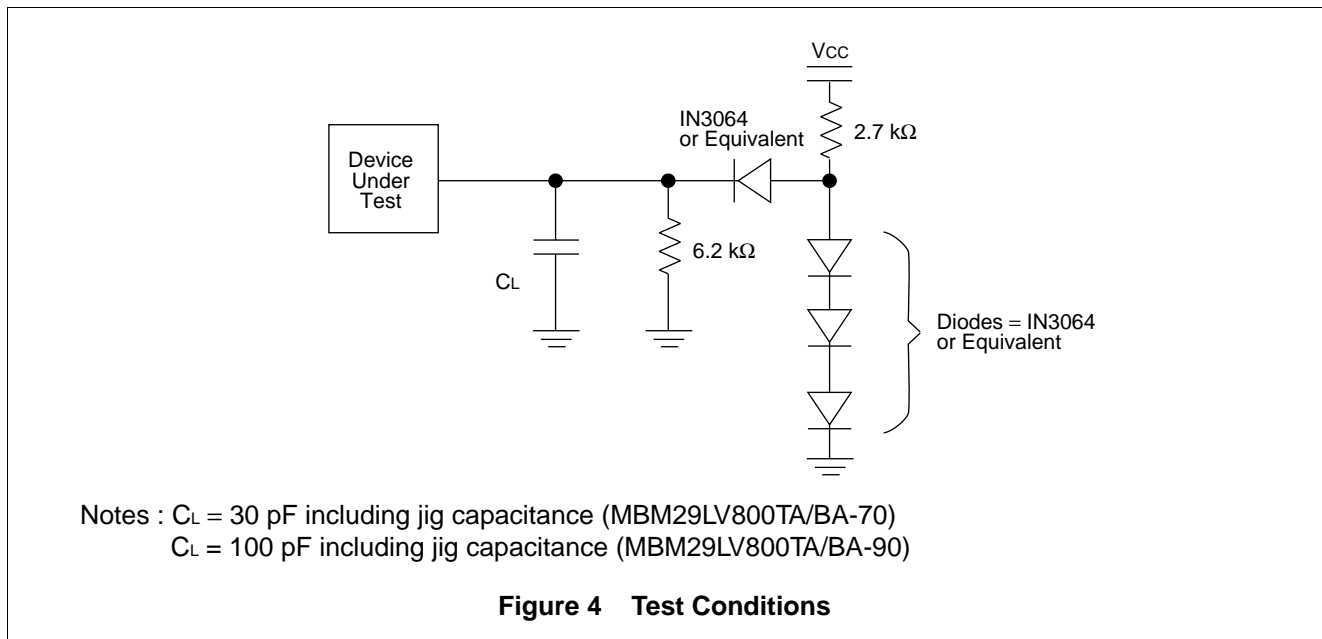

# MBM29LV800TA-70/-90/MBM29LV800BA-70/-90

## • Write/Erase/Program Operations

Parameter	Symbol		-70			-90			Unit
	JEDEC	Standard	Min	Typ	Max	Min	Typ	Max	
Write Cycle Time	t <sub>AVAV</sub>	t <sub>WC</sub>	70	—	—	90	—	—	ns
Address Setup Time	t <sub>AVWL</sub>	t <sub>AS</sub>	0	—	—	0	—	—	ns
Address Hold Time	t <sub>WLAX</sub>	t <sub>AH</sub>	45	—	—	45	—	—	ns
Data Setup Time	t <sub>DVWH</sub>	t <sub>DS</sub>	35	—	—	45	—	—	ns
Data Hold Time	t <sub>WHDX</sub>	t <sub>DH</sub>	0	—	—	0	—	—	ns
Output Enable Setup Time	—	t <sub>OES</sub>	0	—	—	0	—	—	ns
Output Enable Hold Time	Read	t <sub>OEH</sub>	0	—	—	0	—	—	ns
	Toggle and Data Polling		10	—	—	10	—	—	ns
Read Recover Time Before Write	t <sub>GHWL</sub>	t <sub>GHWL</sub>	0	—	—	0	—	—	ns
Read Recover Time Before Write	t <sub>GHEL</sub>	t <sub>GHEL</sub>	0	—	—	0	—	—	ns
$\overline{CE}$ Setup Time	t <sub>ELWL</sub>	t <sub>CS</sub>	0	—	—	0	—	—	ns
$\overline{WE}$ Setup Time	t <sub>WLEL</sub>	t <sub>WS</sub>	0	—	—	0	—	—	ns
$\overline{CE}$ Hold Time	t <sub>WHEH</sub>	t <sub>CH</sub>	0	—	—	0	—	—	ns
$\overline{WE}$ Hold Time	t <sub>EHWH</sub>	t <sub>WH</sub>	0	—	—	0	—	—	ns
Write Pulse Width	t <sub>WLWH</sub>	t <sub>WP</sub>	35	—	—	45	—	—	ns
$\overline{CE}$ Pulse Width	t <sub>ELEH</sub>	t <sub>CP</sub>	35	—	—	45	—	—	ns
Write Pulse Width High	t <sub>WHWL</sub>	t <sub>WPH</sub>	25	—	—	25	—	—	ns
$\overline{CE}$ Pulse Width High	t <sub>EHEL</sub>	t <sub>CPH</sub>	25	—	—	25	—	—	ns
Byte Programming Operation	t <sub>WHWH1</sub>	t <sub>WHWH1</sub>	—	8	—	—	8	—	μs
Sector Erase Operation *1	t <sub>WHWH2</sub>	t <sub>WHWH2</sub>	—	1	—	—	1	—	sec
V <sub>CC</sub> Setup Time	—	t <sub>VCS</sub>	50	—	—	50	—	—	μs
Rise Time to V <sub>ID</sub> *2	—	t <sub>VIDR</sub>	500	—	—	500	—	—	ns
Voltage Transition Time *2	—	t <sub>VLHT</sub>	4	—	—	4	—	—	μs
Write Pulse Width *2	—	t <sub>WPP</sub>	100	—	—	100	—	—	μs
$\overline{OE}$ Setup Time to $\overline{WE}$ Active *2	—	t <sub>OESP</sub>	4	—	—	4	—	—	μs
$\overline{CE}$ Setup Time to $\overline{WE}$ Active *2	—	t <sub>CSP</sub>	4	—	—	4	—	—	μs
Recover Time From RY/ $\overline{BY}$	—	t <sub>RB</sub>	0	—	—	0	—	—	ns
$\overline{RESET}$ Pulse Width	—	t <sub>RP</sub>	500	—	—	500	—	—	ns
$\overline{RESET}$ Hold Time Before Read	—	t <sub>RH</sub>	200	—	—	200	—	—	ns
$\overline{BYTE}$ Switching Low to Output High-Z	—	t <sub>FLQZ</sub>	—	—	30	—	—	35	ns
$\overline{BYTE}$ Switching High to Output Active	—	t <sub>FHQV</sub>	30	—	—	35	—	—	ns
Program/Erase Valid to RY/ $\overline{BY}$ Delay	—	t <sub>BUSY</sub>	—	—	90	—	—	90	ns
Delay Time from Embedded Output Enable	—	t <sub>EOE</sub>	—	—	30	—	—	35	ns

\*1: This does not include the preprogramming time.

\*2: This timing is for Sector Protection operation.

# MBM29LV800TA-70/-90/MBM29LV800BA-70/-90

## ■ ERASE AND PROGRAMMING PERFORMANCE

Parameter	Limit			Unit	Comments
	Min	Typ	Max		
Sector Erase Time	—	1	10	s	Excludes programming time prior to erasure
Word Programming Time	—	16	360	μs	Excludes system-level overhead
Byte Programming Time	—	8	300	μs	
Chip Programming Time	—	8.4	25	s	Excludes system-level overhead
Program/Erase Cycle	100,000	—	—	cycle	—

## ■ PIN CAPACITANCE

### • TSOP(I)

Parameter	Symbol	Test Setup	Typ	Max	Unit
Input Capacitance	C <sub>IN</sub>	V <sub>IN</sub> = 0	7.5	9.5	pF
Output Capacitance	C <sub>OUT</sub>	V <sub>OUT</sub> = 0	8.0	10.0	pF
Control Pin Capacitance	C <sub>IN2</sub>	V <sub>IN</sub> = 0	10.0	13.0	pF

Notes: • Test conditions T<sub>A</sub> = +25°C, f = 1.0 MHz  
 • DQ<sub>15</sub>/A-1 pin capacitance is stipulated by output capacitance.

### • SOP

Parameter	Symbol	Test Setup	Typ	Max	Unit
Input Capacitance	C <sub>IN</sub>	V <sub>IN</sub> = 0	7.5	9.5	pF
Output Capacitance	C <sub>OUT</sub>	V <sub>OUT</sub> = 0	8.0	10.0	pF
Control Pin Capacitance	C <sub>IN2</sub>	V <sub>IN</sub> = 0	10.0	13.0	pF

Notes: • Test conditions T<sub>A</sub> = +25°C, f = 1.0 MHz  
 • DQ<sub>15</sub>/A-1 pin capacitance is stipulated by output capacitance.

### • FBGA

Parameter	Symbol	Test Setup	Typ	Max	Unit
Input Capacitance	C <sub>IN</sub>	V <sub>IN</sub> = 0	7.5	9.5	pF
Output Capacitance	C <sub>OUT</sub>	V <sub>OUT</sub> = 0	8.0	10.0	pF
Control Pin Capacitance	C <sub>IN2</sub>	V <sub>IN</sub> = 0	10.0	13.0	pF

Notes: • Test conditions T<sub>A</sub> = +25°C, f = 1.0 MHz  
 • DQ<sub>15</sub>/A-1 pin capacitance is stipulated by output capacitance.

### • SCSP

Parameter	Symbol	Test Setup	Typ	Max	Unit
Input Capacitance	C <sub>IN</sub>	V <sub>IN</sub> = 0	7.5	9.5	pF
Output Capacitance	C <sub>OUT</sub>	V <sub>OUT</sub> = 0	8.0	10.0	pF
Control Pin Capacitance	C <sub>IN2</sub>	V <sub>IN</sub> = 0	10.0	13.0	pF

Notes: • Test conditions T<sub>A</sub> = +25°C, f = 1.0 MHz  
 • DQ<sub>15</sub>/A-1 pin capacitance is stipulated by output capacitance.

## SWITCHING WAVEFORMS

### Key to Switching Waveforms

WAVEFORM	INPUTS	OUTPUTS
	Must Be Steady	Will Be Steady
	May Change from H to L	Will Be Changing from H to L
	May Change from L to H	Will Be Changing from L to H
	"H" or "L" Any Change Permitted	Changing State Unknown
	Does Not Apply	Center Line is High-Impedance "Off" State

### 1. AC Waveforms for Read Operations

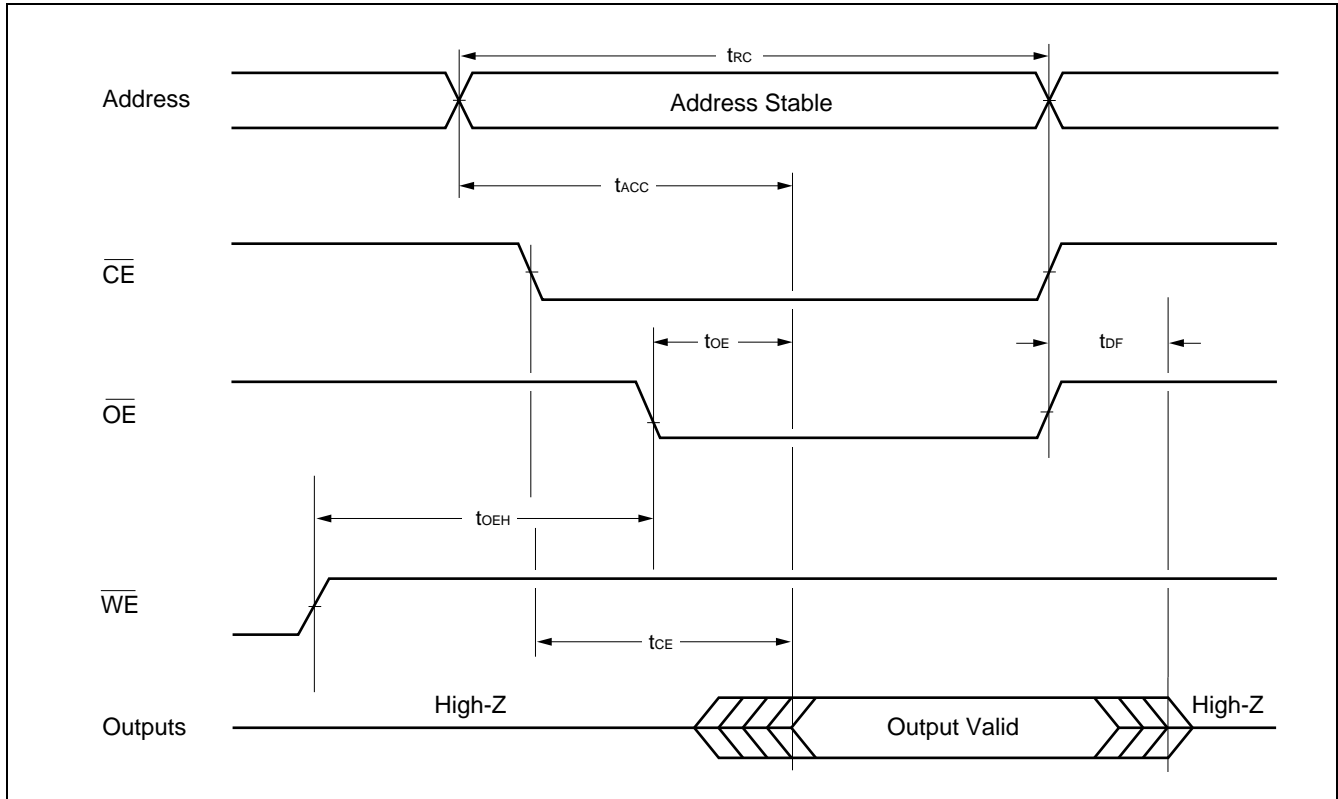

## 2. AC Waveforms for Hardware Reset/Read Operations

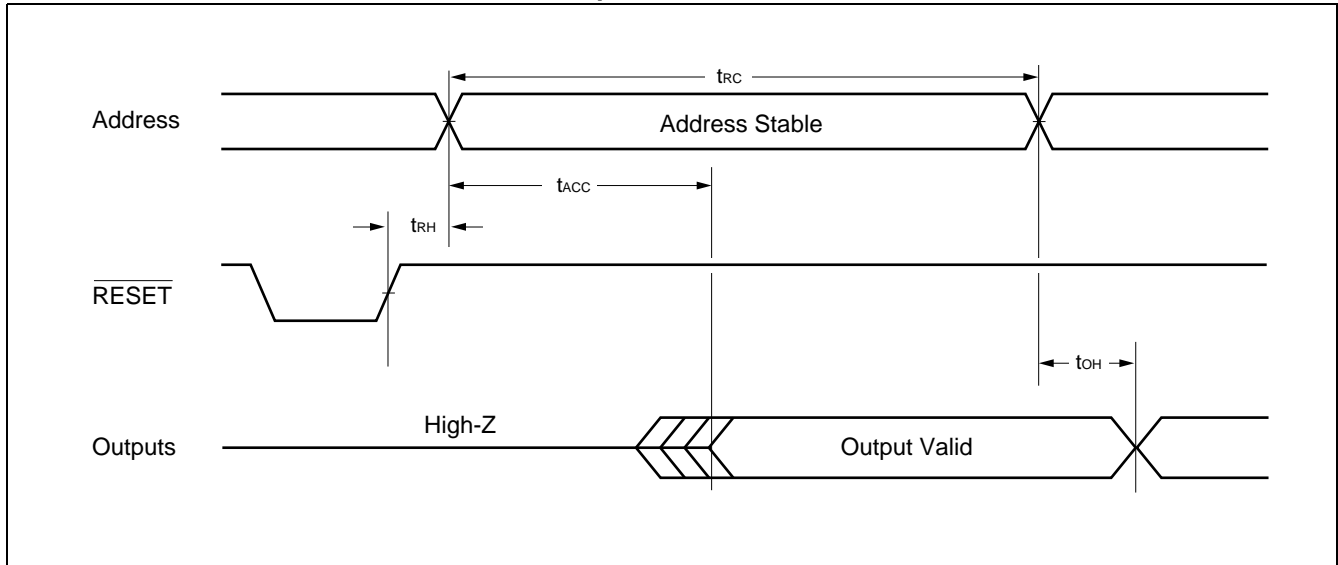

## 3. AC Waveforms for Alternate $\overline{WE}$ Controlled Program Operations

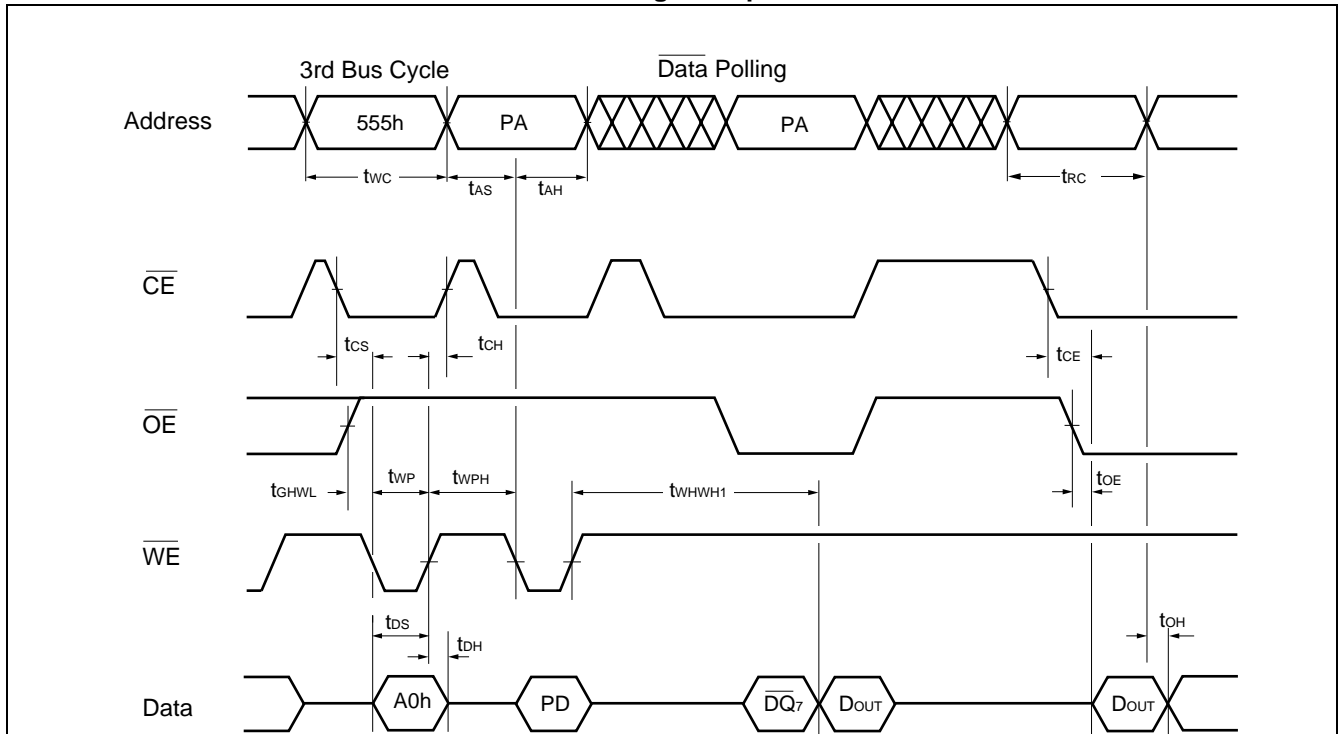

- Notes:**
- PA is address of the memory location to be programmed.
  - PD is data to be programmed at byte address.
  - $\overline{DQ}_7$  is the output of the complement of the data written to the device.
  - DOUT is the output of the data written to the device.
  - Figure indicates last two bus cycles out of four bus cycle sequence.
  - These waveforms are for the  $\times 16$  mode. (The addresses differ from  $\times 8$  mode.)

## 4. AC Waveforms for Alternate $\overline{\text{CE}}$ Controlled Program Operations

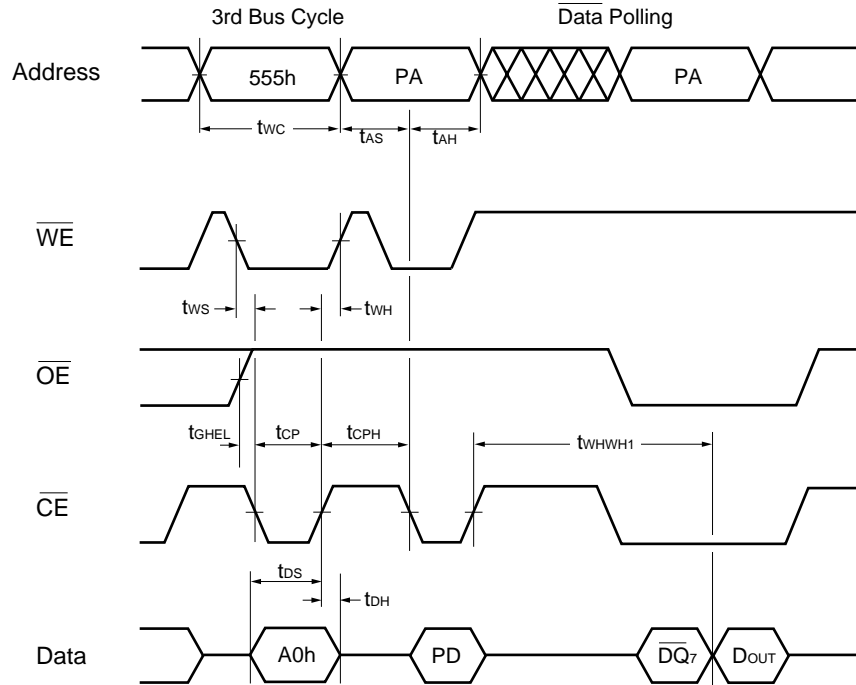

- Notes:**
- PA is address of the memory location to be programmed.
  - PD is data to be programmed at byte address.
  - $\overline{\text{DQ}}_7$  is the output of the complement of the data written to the device.
  - $\text{D}_{\text{OUT}}$  is the output of the data written to the device.
  - Figure indicates last two bus cycles out of four bus cycle sequence.
  - These waveforms are for the  $\times 16$  mode. (The addresses differ from  $\times 8$  mode.)

## 5. AC Waveforms Chip/Sector Erase Operations

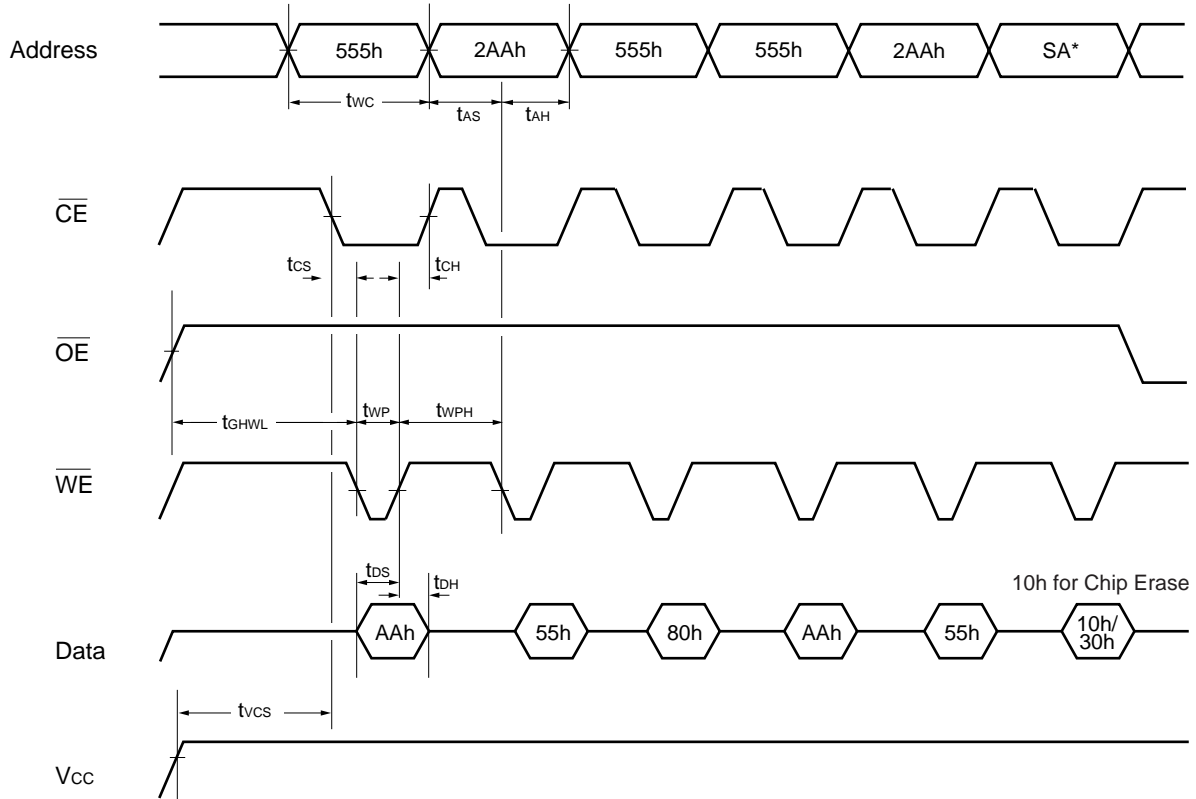

\*: SA is the sector address for Sector Erase. Addresses = 555h (Word), AAh (Byte) for Chip Erase.

Note: These waveforms are for the ×16 mode. The addresses differ from ×8 mode.

## 6. AC Waveforms for Data Polling during Embedded Algorithm Operations

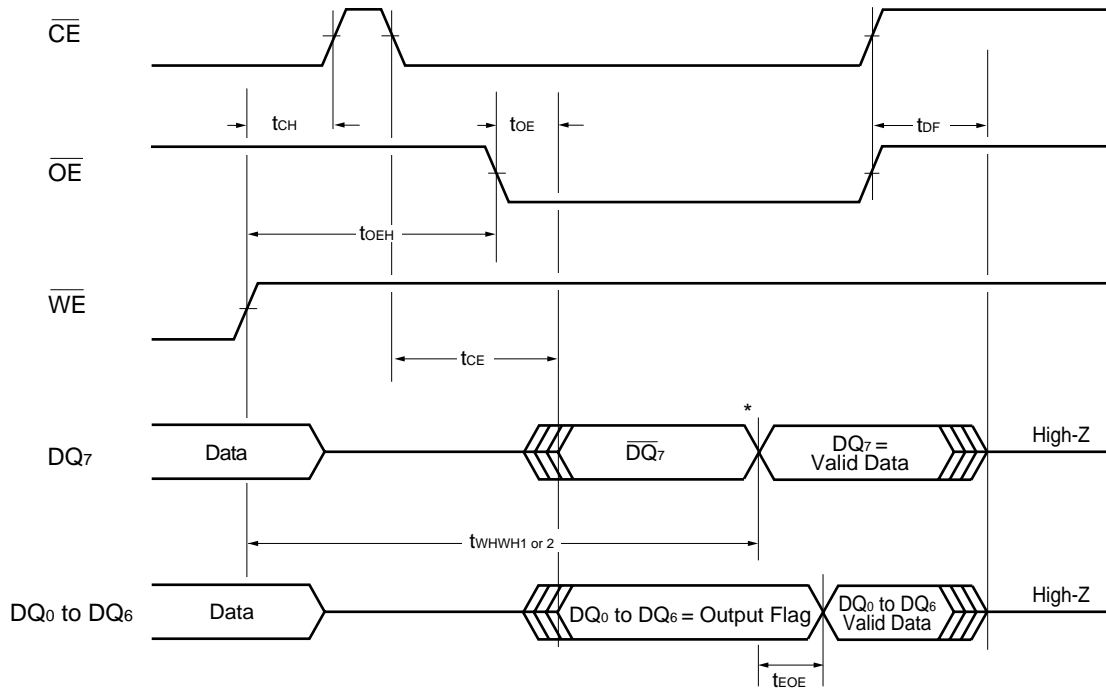

\*:  $DQ_7$  = Valid Data (The device has completed the Embedded operation).

## 7. AC Waveforms for Toggle Bit I during Embedded Algorithm Operations

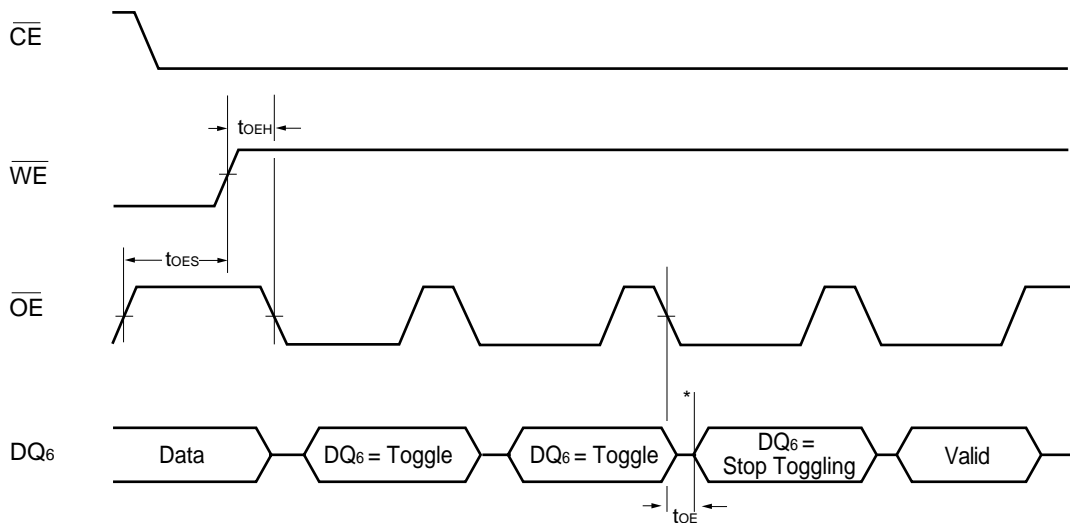

\*:  $DQ_6$  stops toggling (The device has completed the Embedded operation).

# MBM29LV800TA-70/-90/MBM29LV800BA-70/-90

## 8. RY/BY Timing Diagram during Program/Erase Operations

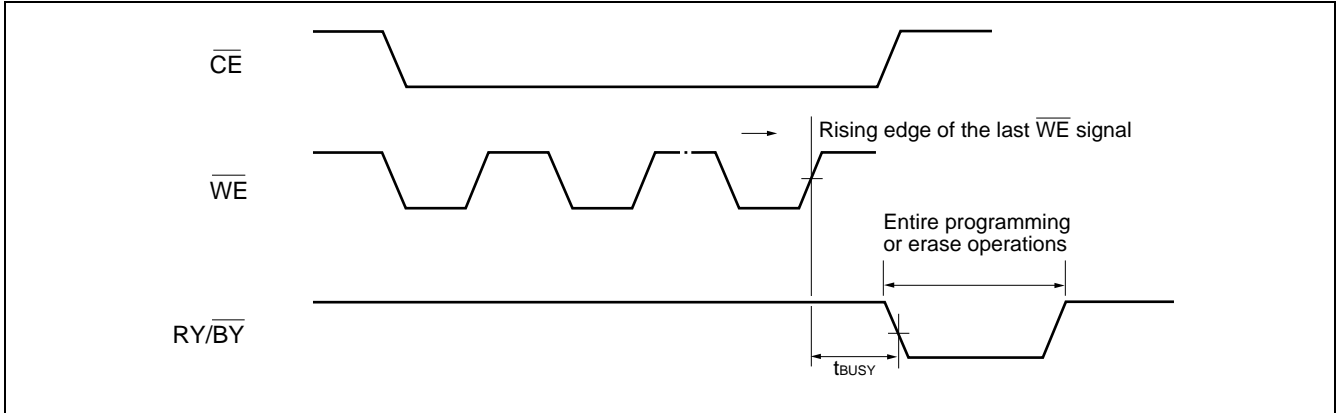

## 9. RESET/RY/BY Timing Diagram

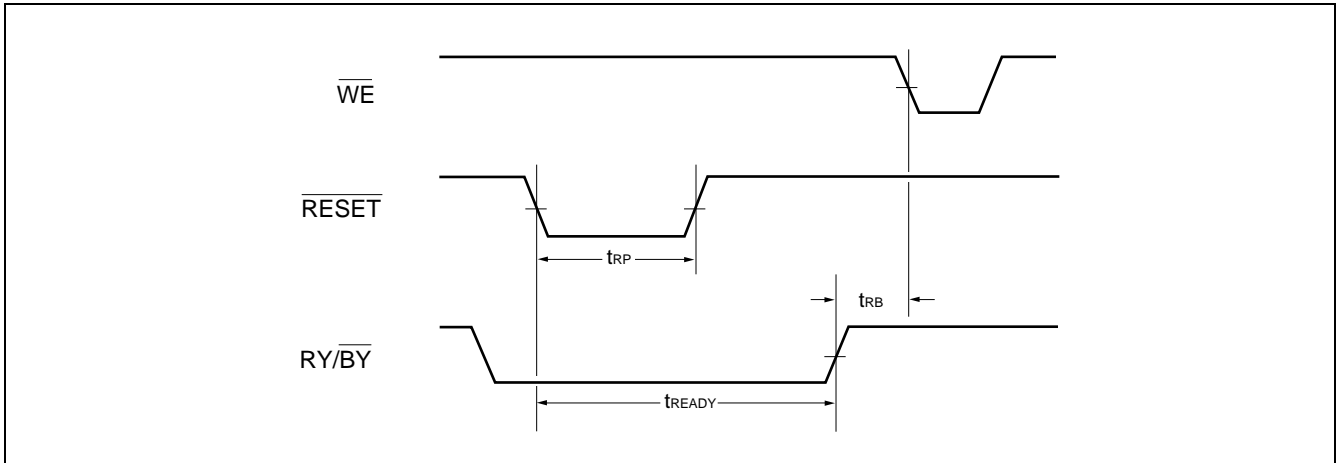

## 10. Timing Diagram for Word Mode Configuration

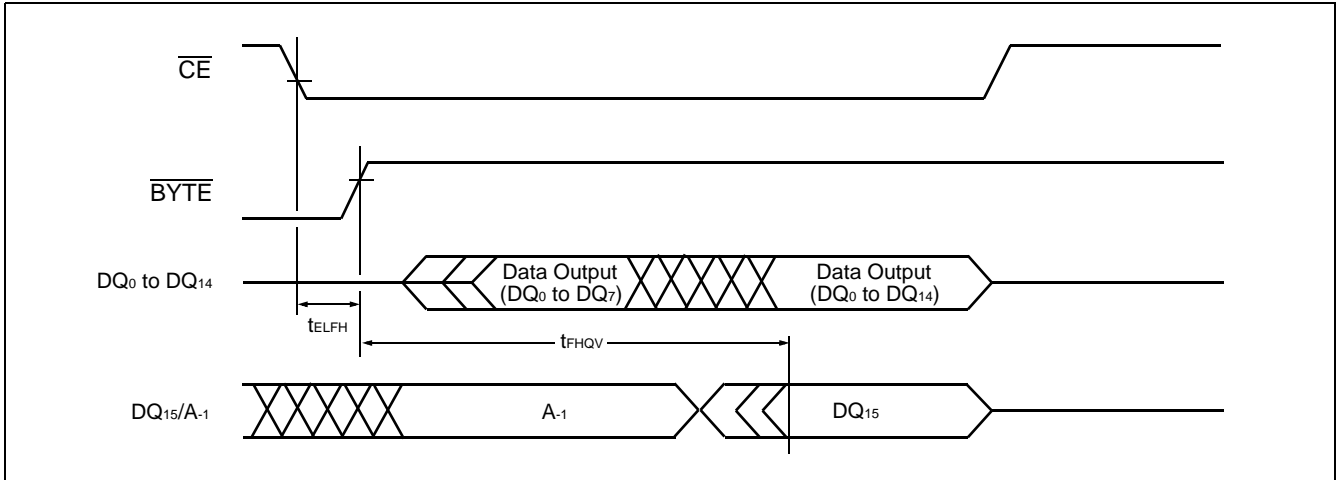

## 11. Timing Diagram for Byte Mode Configuration

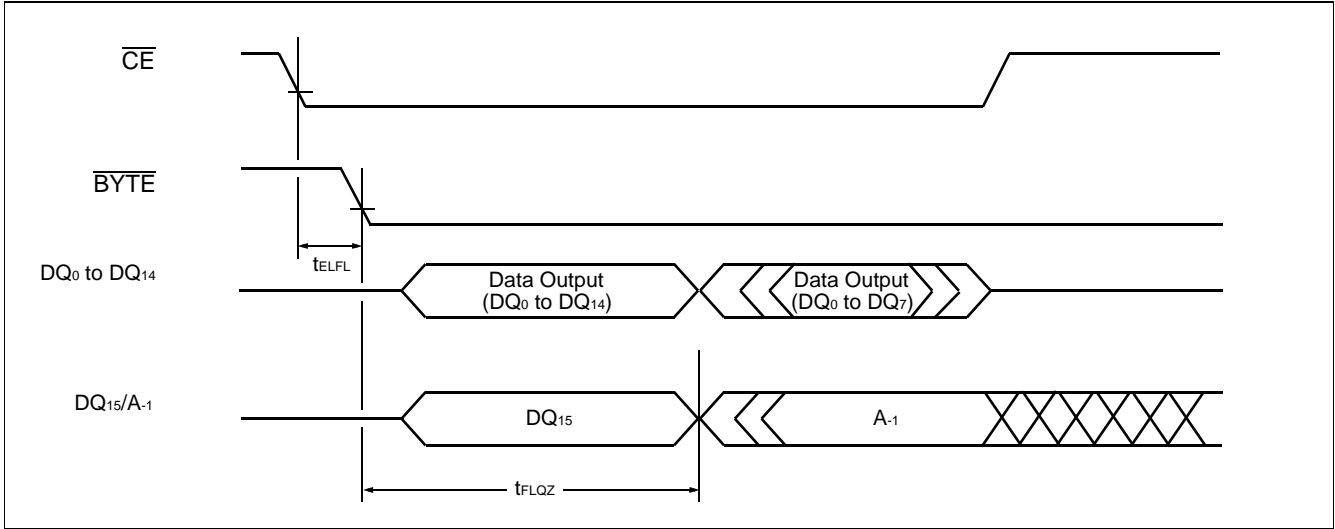

## 12. $\overline{BYTE}$ Timing Diagram for Write Operations

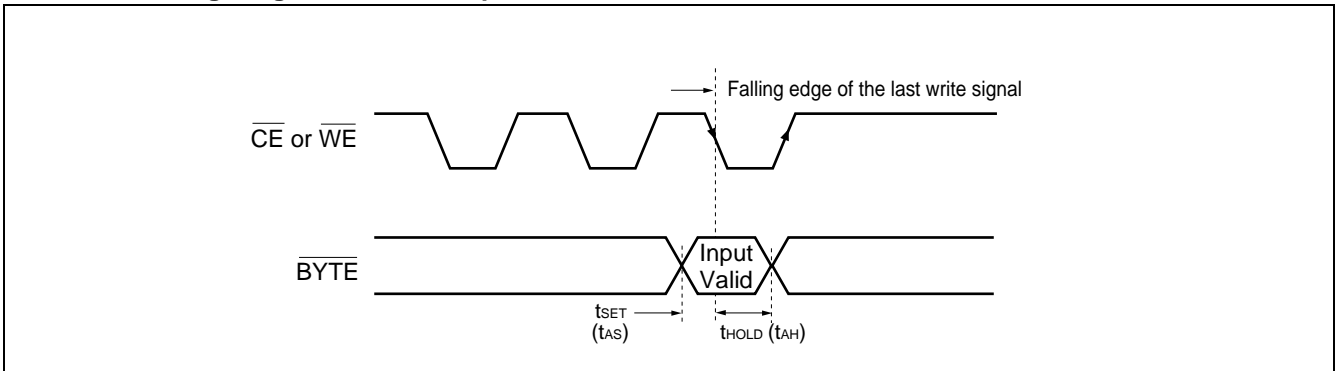

## 13. AC Waveforms for Sector Protection Timing Diagram

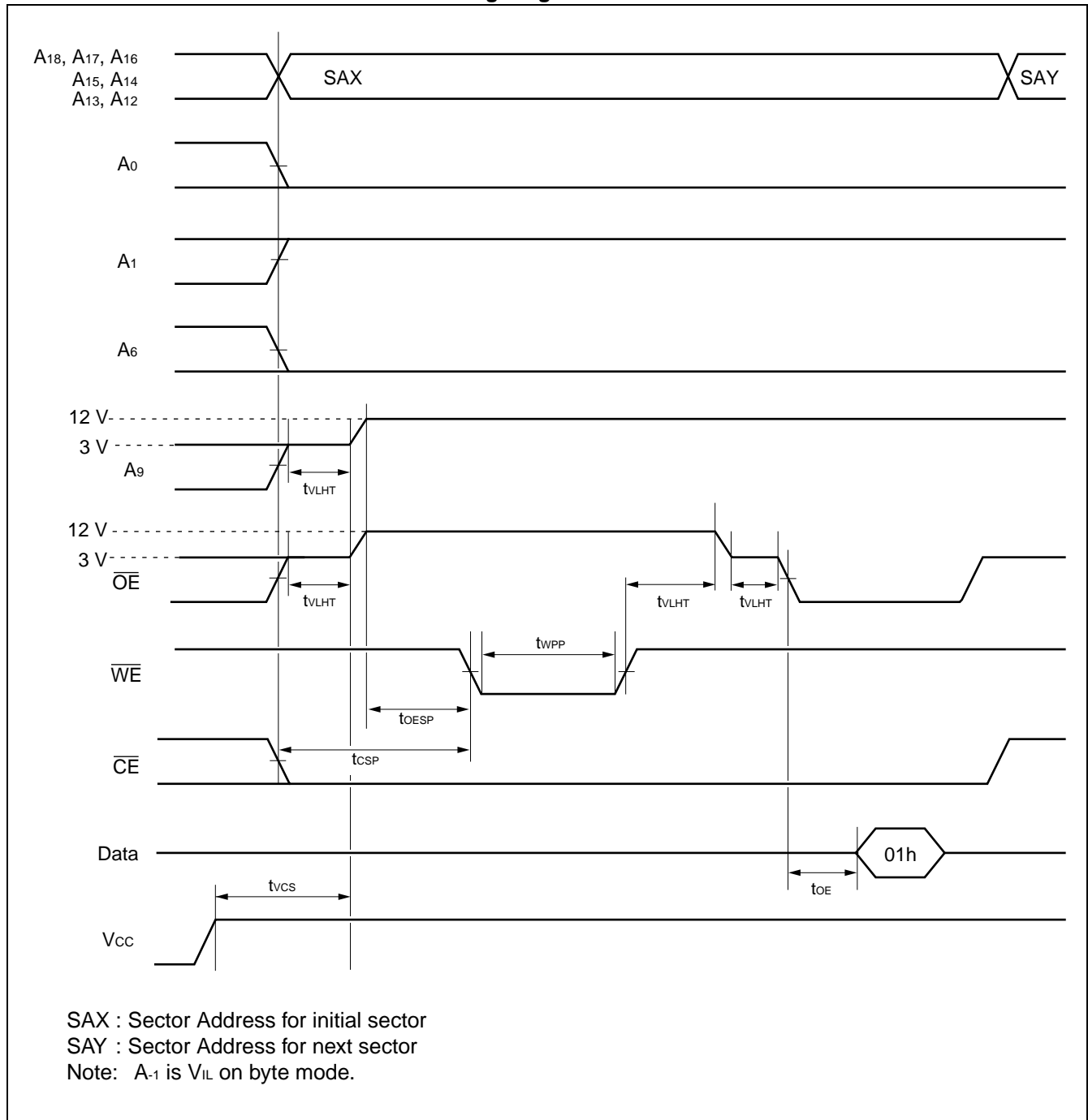

## 14. Temporary Sector Unprotection Timing Diagram

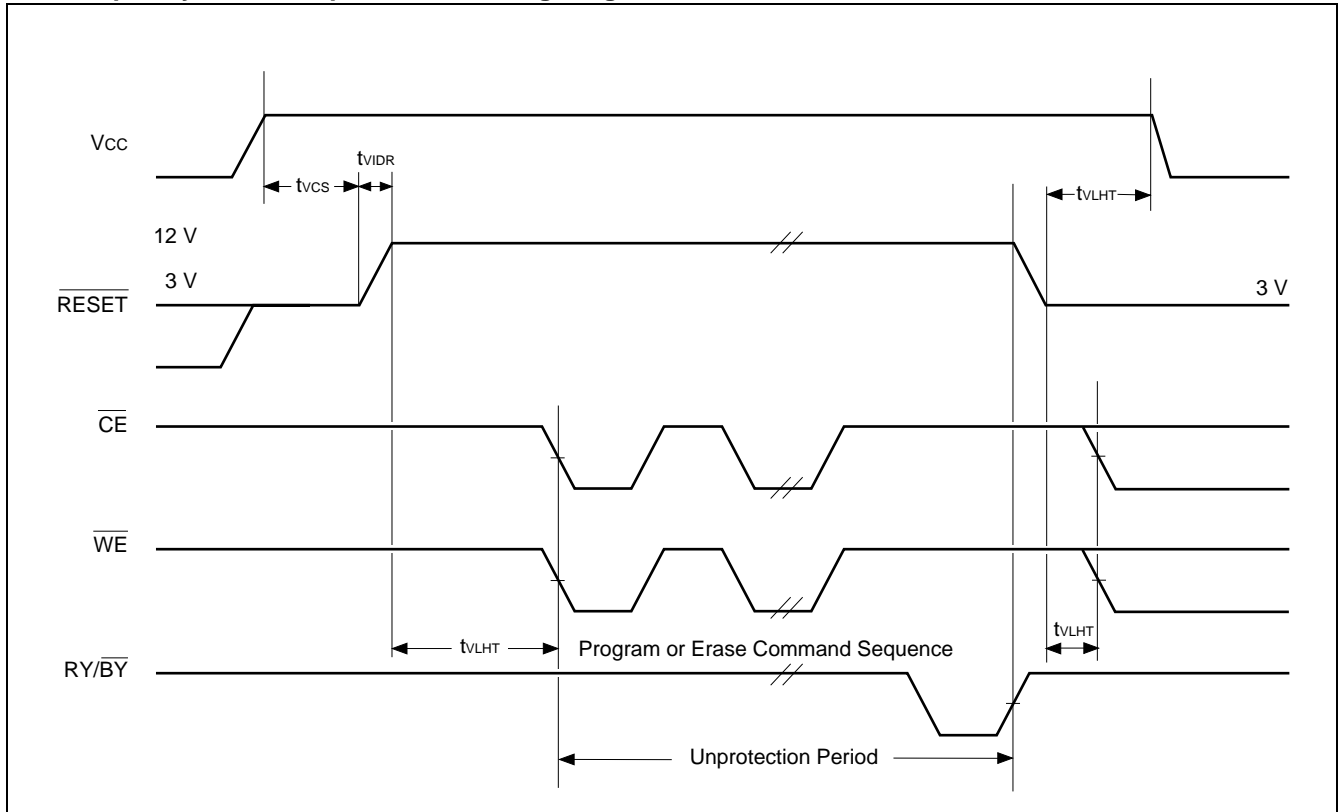

## 15. DQ<sub>2</sub> vs. DQ<sub>6</sub>

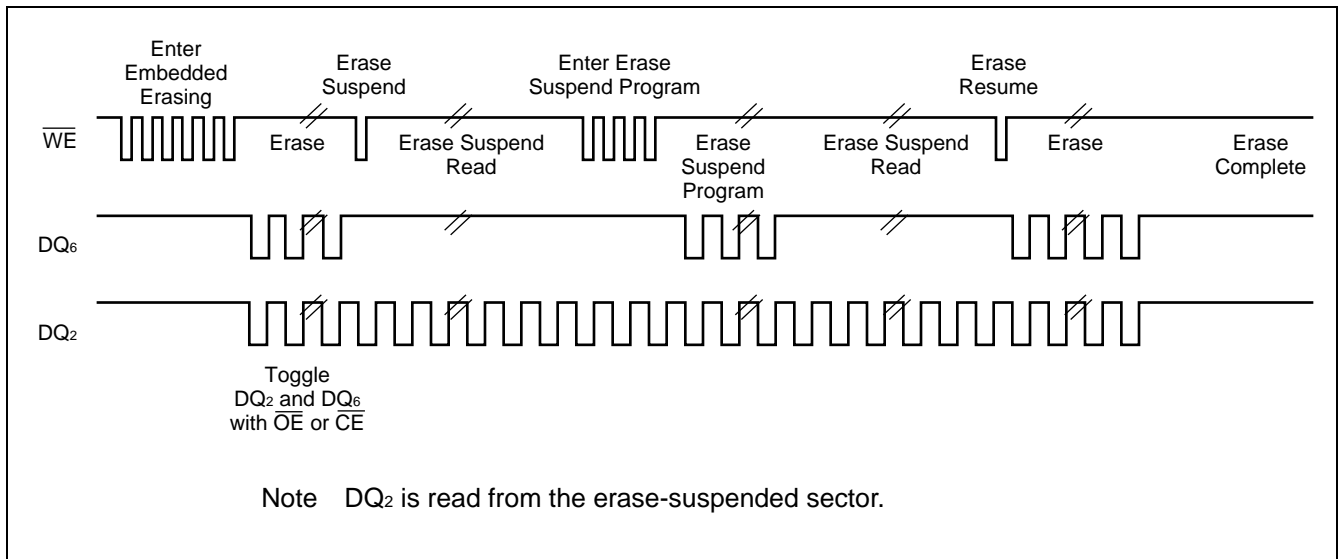

## 16. Extended Sector Protection Timing Diagram

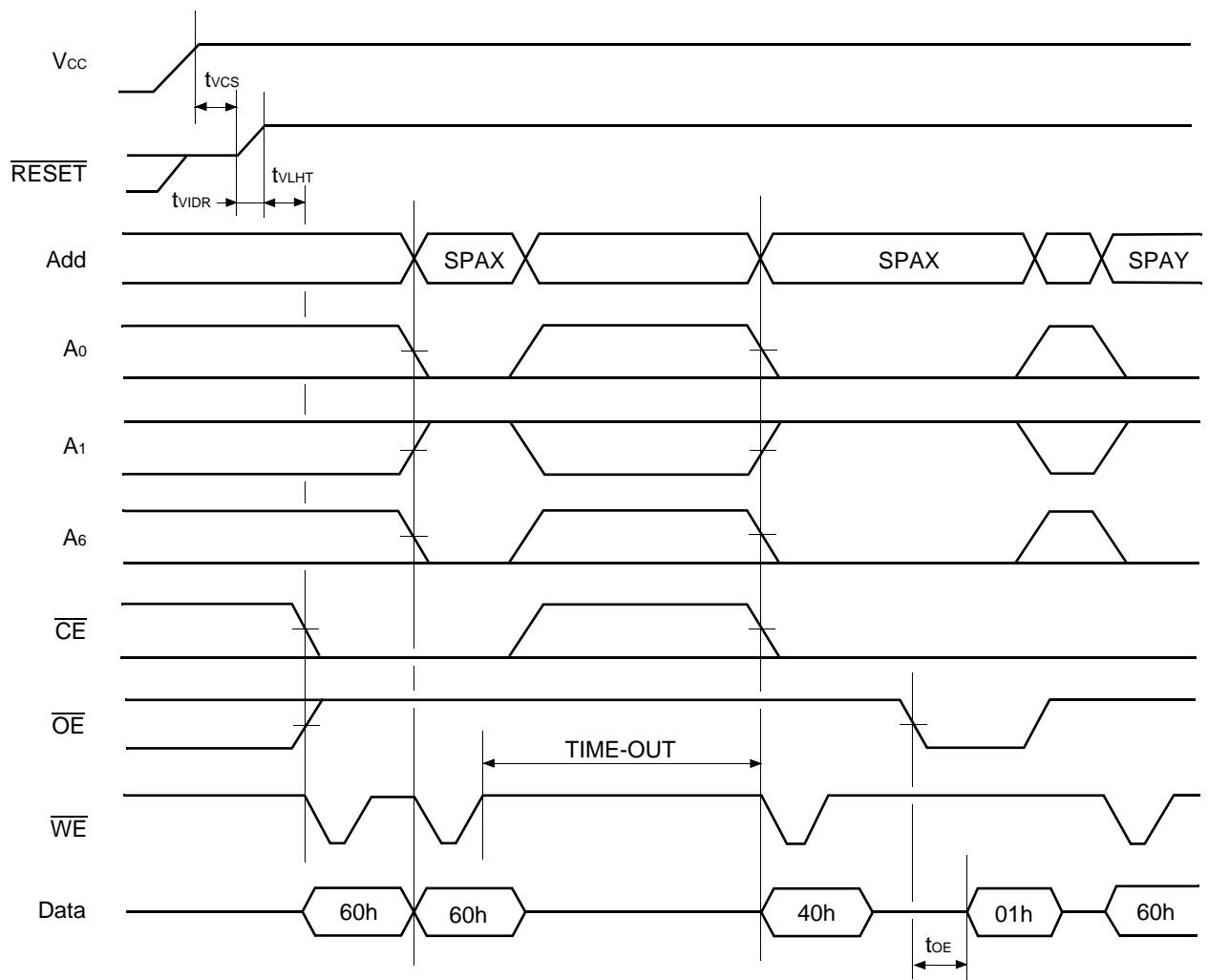

SPAX : Sector Address to be protected  
 SPAY : Next Sector Address to be protected  
 TIME-OUT : Time-Out window = 150  $\mu$ s (Min)

## ■ FLOW CHART

### 1. Embedded Program™ Algorithm

#### EMBEDDED ALGORITHMS

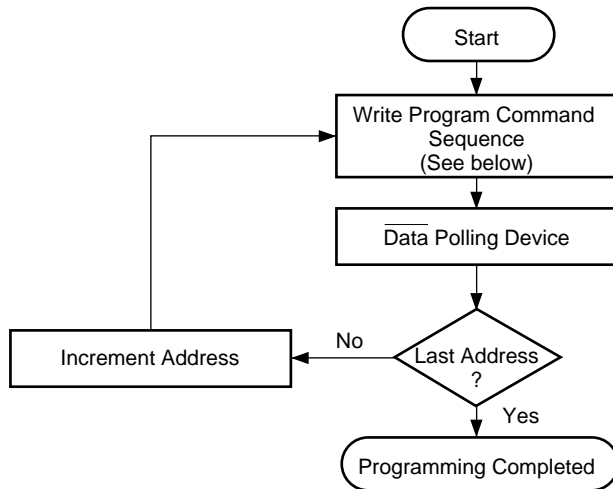

#### Program Command Sequence\* (Address/Command):

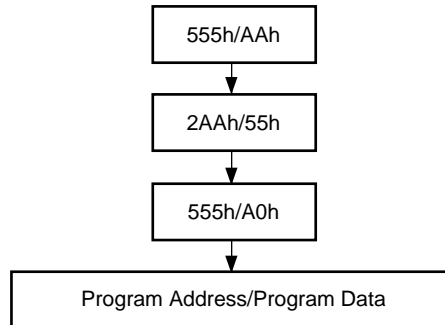

\*: The sequence is applied for  $\times 16$  mode.  
The addresses differ from  $\times 8$  mode.

## 2. Embedded Erase™ Algorithm

### EMBEDDED ALGORITHMS

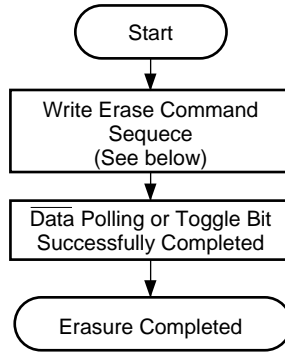

**Chip Erase Command Sequence\***  
(Address/Command):

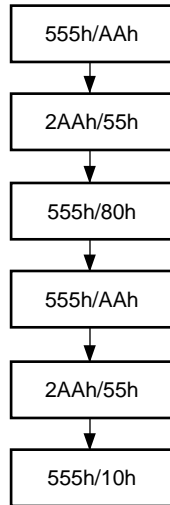

**Individual Sector/Multiple Sector\***  
**Erase Command Sequence**  
(Address/Command):

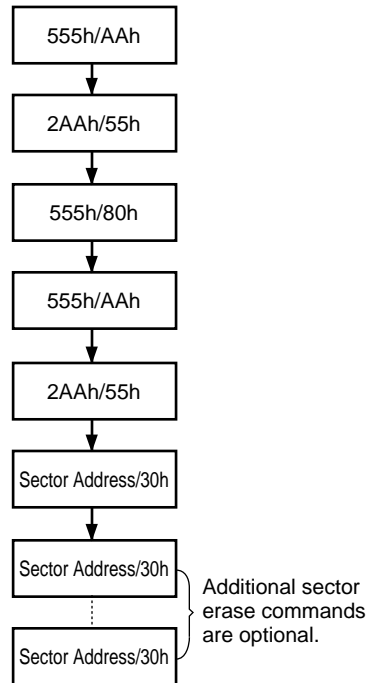

\*: The sequence is applied for × 16 mode.  
The addresses differ from × 8 mode.

## 3. Data Polling Algorithm

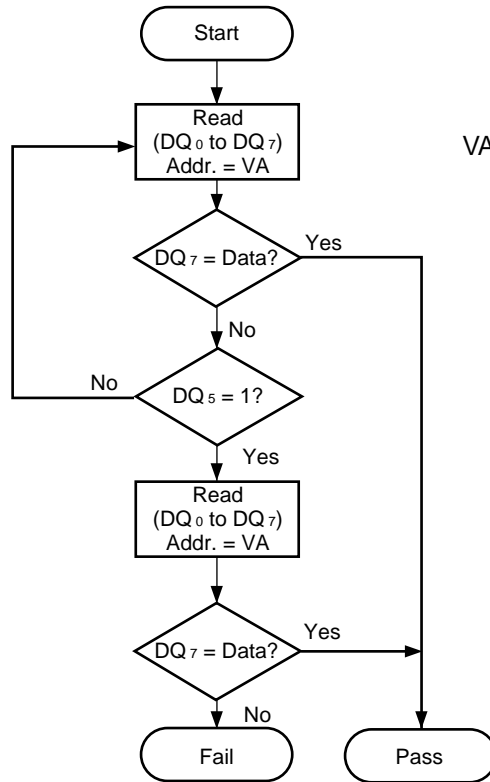

VA = Byte address for programming  
 = Any of the sector addresses within the sector being erased during sector erase or multiple sector erases operation  
 = Any of the sector addresses within the sector not being protected during chip erase

Note: DQ<sub>7</sub> is rechecked even if DQ<sub>5</sub> = "1" because DQ<sub>7</sub> may change simultaneously with DQ<sub>5</sub>.

## 4. Toggle Bit Algorithm

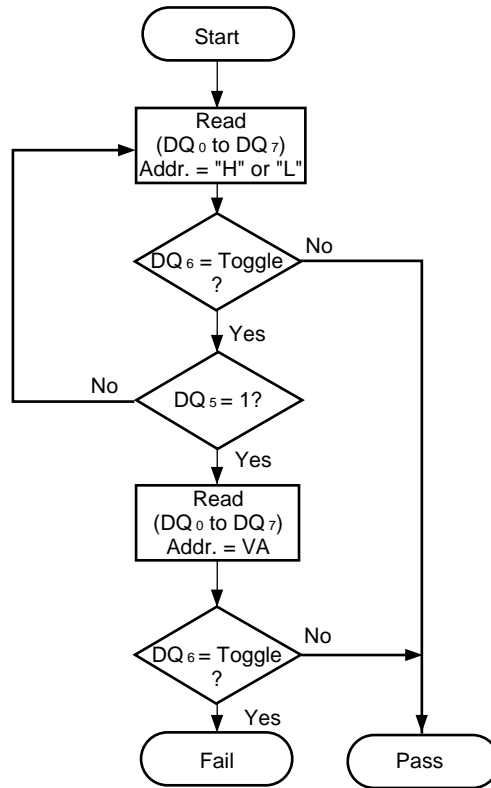

Note: DQ<sub>6</sub> is rechecked even if DQ<sub>5</sub> = "1" because DQ<sub>6</sub> may stop toggling at the same time as DQ<sub>5</sub> changing to "1".

## 5. Sector Protection Algorithm

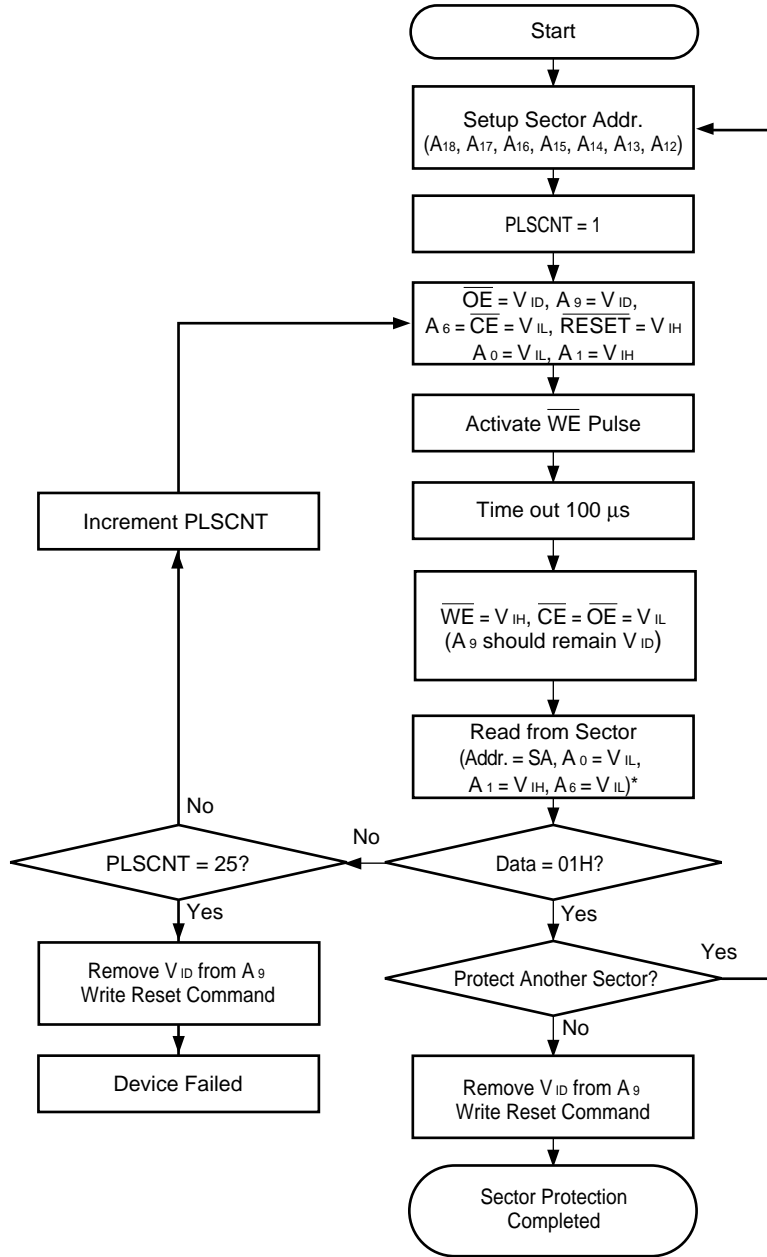

\*: A-1 is V<sub>IL</sub> on byte mode.

## 6. Temporary Sector Unprotection Algorithm

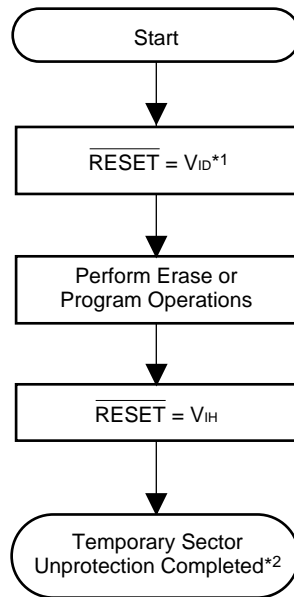

\*1 : All protected sectors are unprotected.

\*2 : All previously protected sectors are protected once again.

## 7. Extended Sector Protection Algorithm

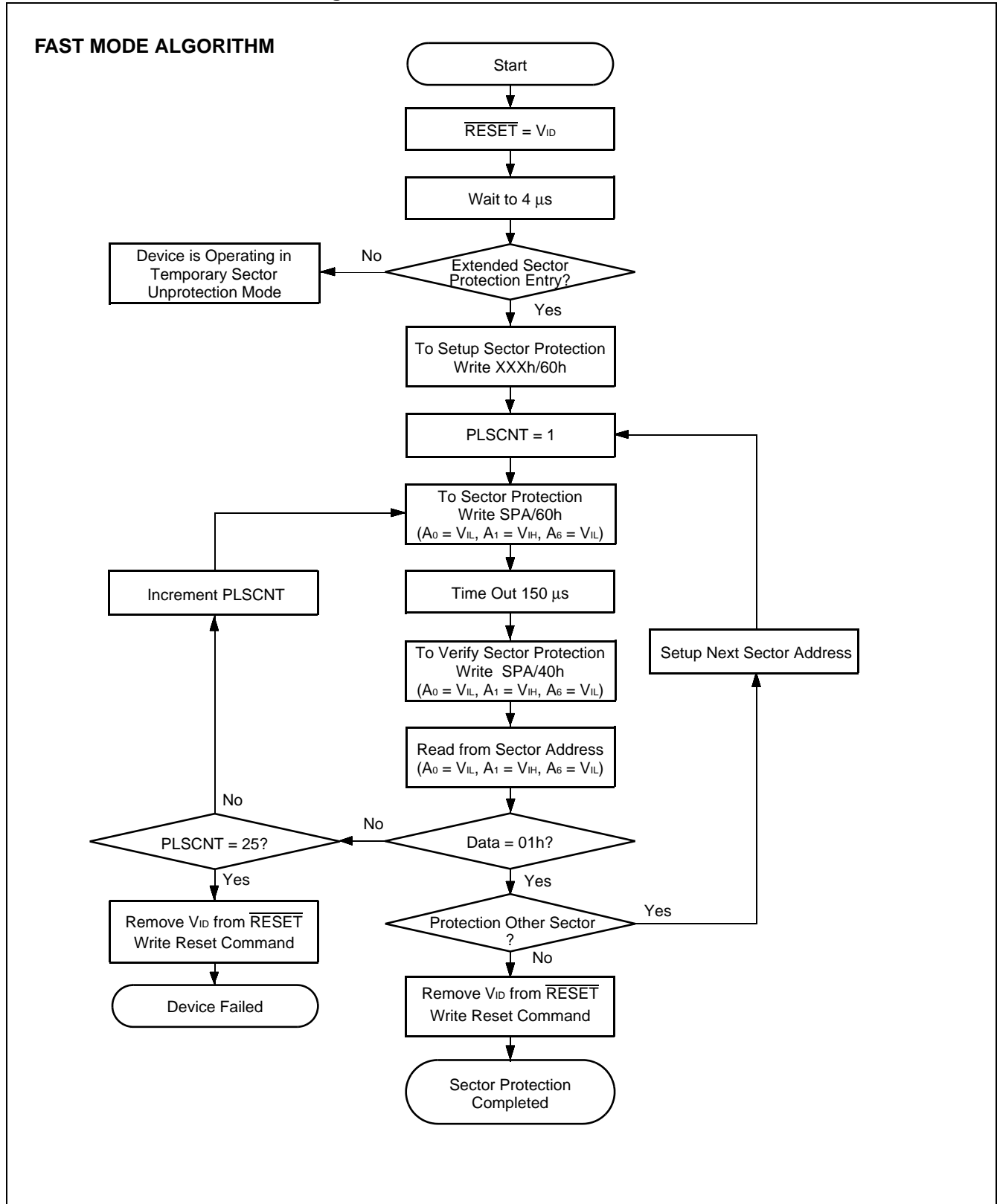

## 8. Embedded Program™ Algorithm for Fast Mode

### FAST MODE ALGORITHM

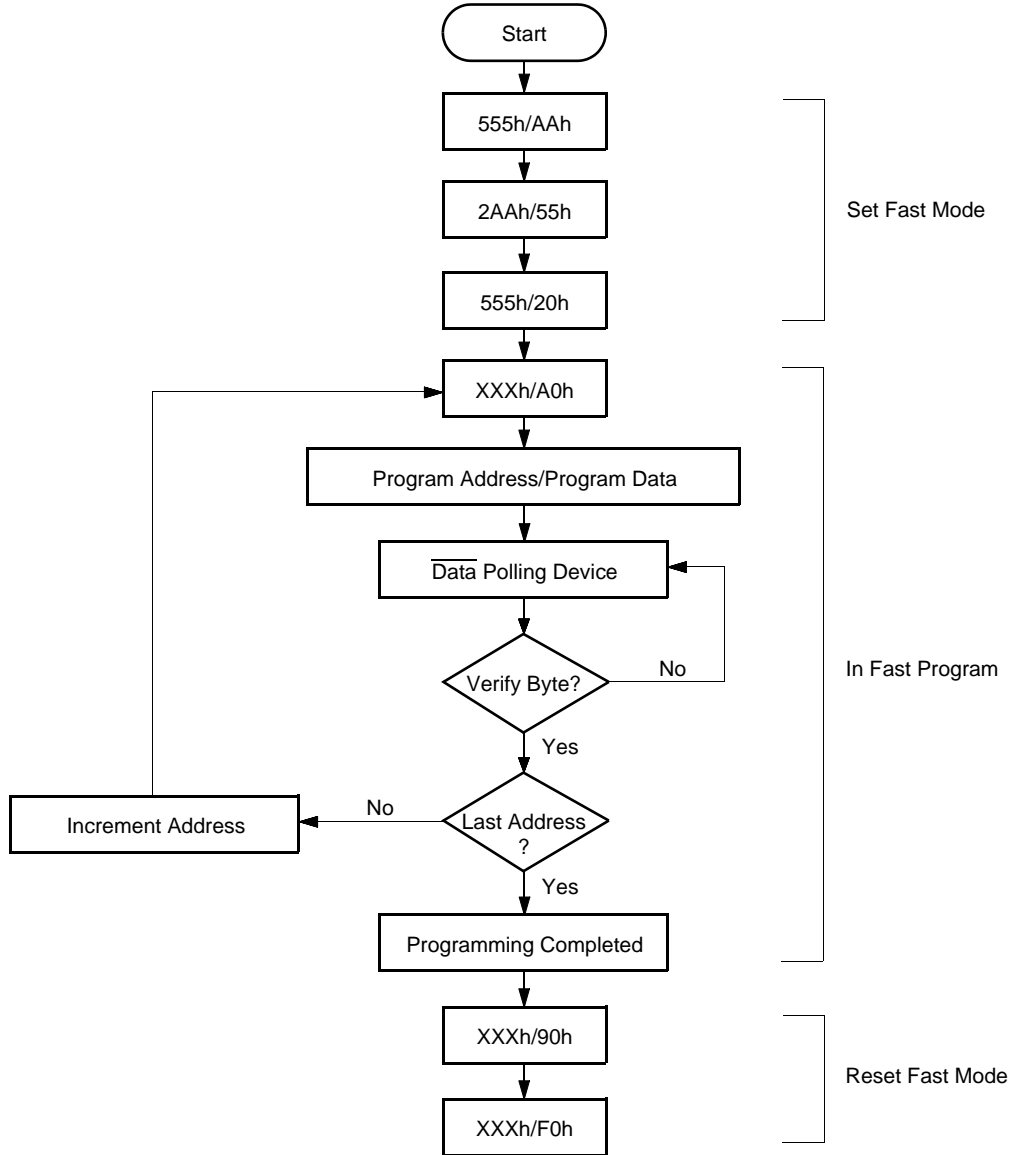

Note: The sequence is applied for × 16 mode.  
The addresses differ from × 8 mode.

# MBM29LV800TA-70/-90/MBM29LV800BA-70/-90

## ■ ORDERING INFORMATION

### Standard Products

Fujitsu standard products are available in several packages. The order number is formed by a combination of:

MBM29LV800 T A -70 PFTN

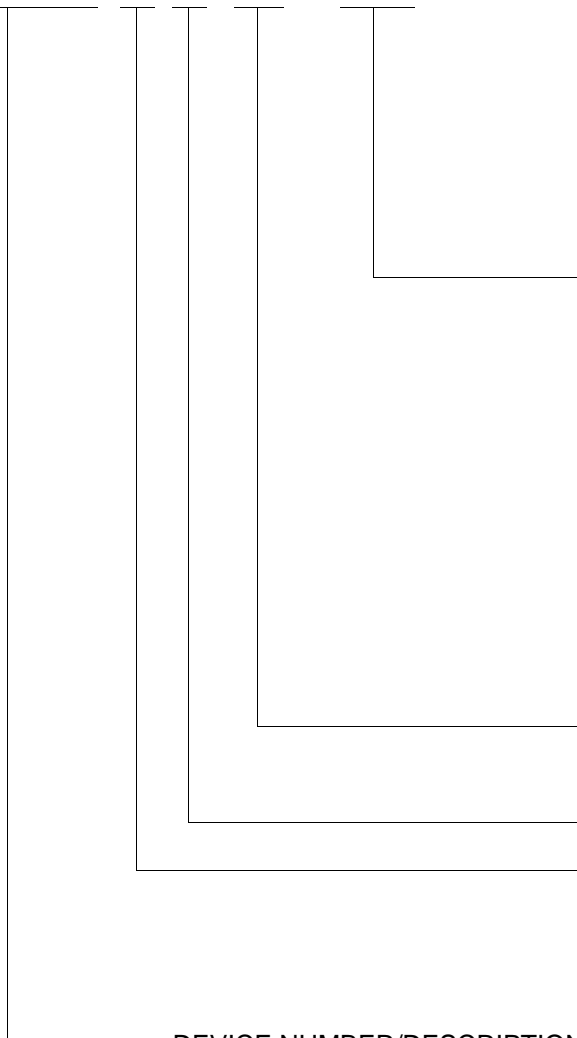

#### PACKAGE TYPE

- PFTN = 48-Pin Thin Small Outline Package (TSOP) Normal Bend
- PFTR = 48-Pin Thin Small Outline Package (TSOP) Reverse Bend
- PF = 44-Pin Small Outline Package
- PBT = 48-Ball Fine Pitch Ball Grid Array Package (FBGA:BGA-48P-M02)
- PBT-SF2 = 48-Ball Fine Pitch Ball Grid Array Package (FBGA:BGA-48P-M12)
- PW= 48-Ball Super Chip Size Package (SCSP)

#### SPEED OPTION

See Product Selector Guide

#### Device Revision

#### BOOT CODE SECTOR ARCHITECTURE

- T = Top sector
- B = Bottom sector

#### DEVICE NUMBER/DESCRIPTION

MBM29LV800

8Mega-bit (1M × 8-Bit or 512K × 16-Bit) CMOS Flash Memory  
3.0 V-only Read, Program, and Erase

# MBM29LV800TA-70/-90/MBM29LV800BA-70/-90

## PACKAGE DIMENSIONS

48-pin plastic TSOP(1)  
(FPT-48P-M19)

Note 1: \*Resin protrusion. (Each side: 0.15(.006)Max)  
Note 2: Pins width and pins thickness include plating thickness.

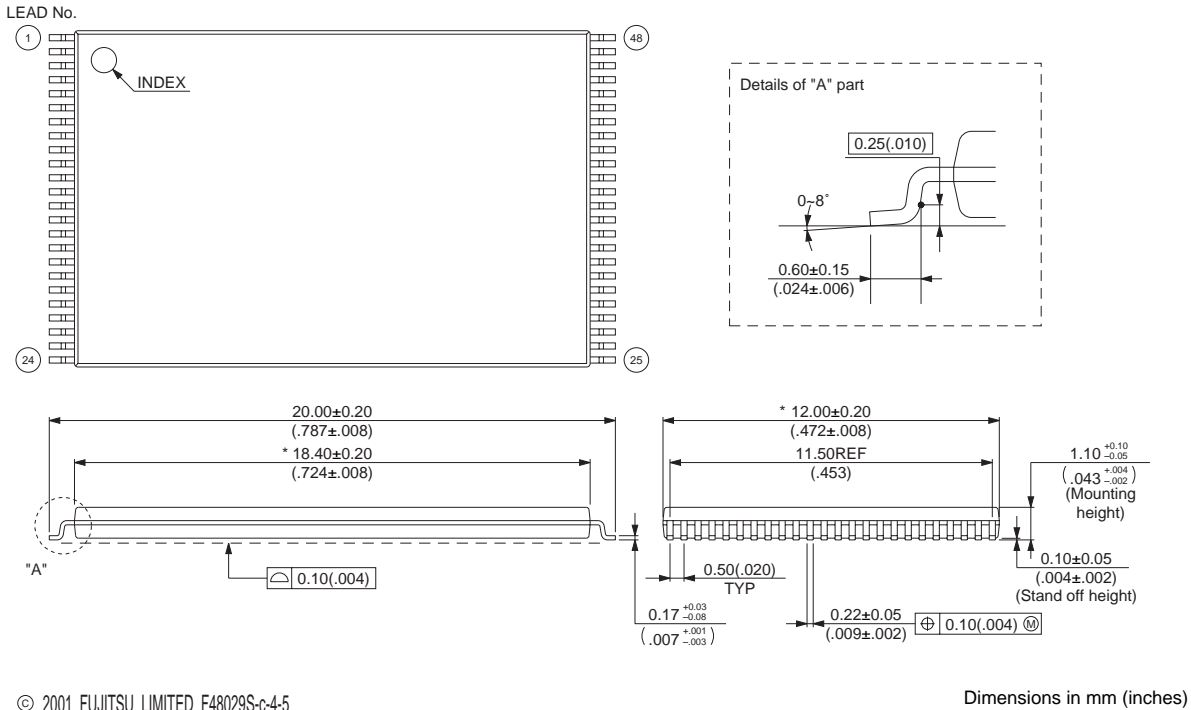

48-pin plastic TSOP(1)  
(FPT-48P-M20)

Note 1: \*Resin protrusion. (Each side: 0.15(.006)Max)  
Note 2: Pins width and pins thickness include plating thickness.

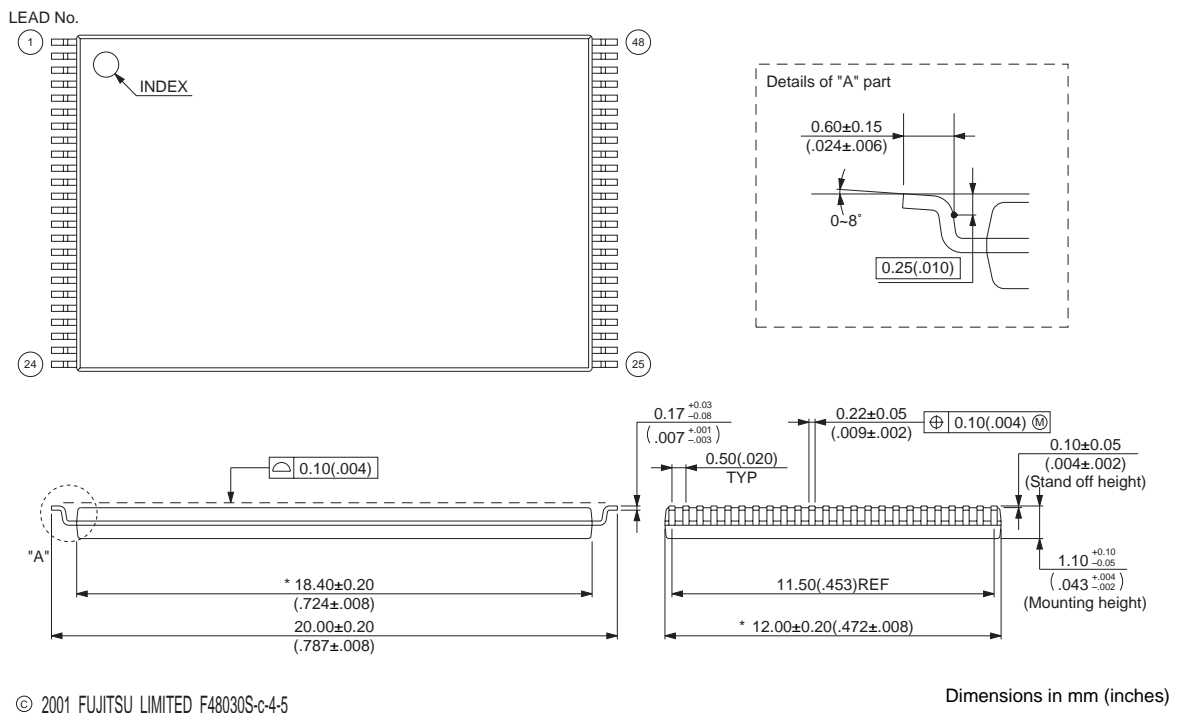

(Continued)





## FUJITSU LIMITED

All Rights Reserved.

The contents of this document are subject to change without notice. Customers are advised to consult with FUJITSU sales representatives before ordering.

The information and circuit diagrams in this document are presented as examples of semiconductor device applications, and are not intended to be incorporated in devices for actual use. Also, FUJITSU is unable to assume responsibility for infringement of any patent rights or other rights of third parties arising from the use of this information or circuit diagrams.

The products described in this document are designed, developed and manufactured as contemplated for general use, including without limitation, ordinary industrial use, general office use, personal use, and household use, but are not designed, developed and manufactured as contemplated (1) for use accompanying fatal risks or dangers that, unless extremely high safety is secured, could have a serious effect to the public, and could lead directly to death, personal injury, severe physical damage or other loss (i.e., nuclear reaction control in nuclear facility, aircraft flight control, air traffic control, mass transport control, medical life support system, missile launch control in weapon system), or (2) for use requiring extremely high reliability (i.e., submersible repeater and artificial satellite).

Please note that Fujitsu will not be liable against you and/or any third party for any claims or damages arising in connection with above-mentioned uses of the products.

Any semiconductor devices have an inherent chance of failure. You must protect against injury, damage or loss from such failures by incorporating safety design measures into your facility and equipment such as redundancy, fire protection, and prevention of over-current levels and other abnormal operating conditions.

If any products described in this document represent goods or technologies subject to certain restrictions on export under the Foreign Exchange and Foreign Trade Law of Japan, the prior authorization by Japanese government will be required for export of those products from Japan.

F0207

© FUJITSU LIMITED Printed in Japan