

Advance Information

256K x 72 Bit BurstRAM

Multichip Module

The 256K x 72 multichip module uses four 4M bit synchronous fast static RAMs designed to provide a burstable, high performance, secondary cache for the PowerPC™ and other high performance microprocessors. It is organized as 256K words of 72 bits each. This device integrates input registers, an output register (MCM72PB8ML only), a 2-bit address counter, and high speed SRAM onto a single monolithic circuit for reduced parts count in cache data RAM applications. Synchronous design allows precise cycle control with the use of an external clock (K). BiCMOS circuitry reduces the overall power consumption of the integrated functions for greater reliability.

Addresses (SA), data inputs (DQx), and all control signals except output enable (\overline{G}) and linear burst order (\overline{LBO}) are clock (K) controlled through positive-edge-triggered noninverting registers.

Bursts can be initiated with either \overline{ADSP} or \overline{ADSC} input pins. Subsequent burst addresses can be generated internally (burst sequence operates in linear or interleaved mode dependent upon the state of \overline{LBO}) and controlled by the burst address advance (ADV) input pin.

Write cycles are internally self-timed and are initiated by the rising edge of the clock (K) input. This feature eliminates complex off-chip write pulse generation and provides increased timing flexibility for incoming signals.

Synchronous byte write (\overline{SBx}), synchronous global write (\overline{SGW}), and synchronous write enable (\overline{SW}) are provided to allow writes to either individual bytes or to all bytes. The eight bytes are designated as "a" through "h". \overline{SBa} controls DQa, \overline{SBb} controls DQb, etc. Individual bytes are written if the selected byte writes \overline{SBx} are asserted with \overline{SW} . All bytes are written if either \overline{SGW} is asserted or if all \overline{SBx} and \overline{SW} are asserted.

The module can be configured as either a pipelined or flow-through SRAM. For read cycles, pipelined SRAMs output data is temporarily stored by an edge-triggered output register and then released to the output buffers at the next rising edge of clock (K). Flow-through SRAMs allow output to simply flow freely from the memory array.

The multichip module operates from a 3.3 V core power supply and all outputs operate on a separate 2.5 V or 3.3 V power supply. All inputs and outputs are JEDEC standard JESD8-5 compatible.

- 3.3 V + 10%, - 5% Core Power Supply, 2.5 V or 3.3 V I/O Supply
- \overline{ADSP} , \overline{ADSC} , and \overline{ADV} Burst Control Pins
- Option for Pipeline or Flow-Through (Speeds Guaranteed When Module is Purchased by Appropriate Part Number)
- Selectable Burst Sequencing Order (Linear/Interleaved)
- Single-Cycle Deselect Timing
- Internally Self-Timed Write Cycle
- Byte Write and Global Write Control
- JEDEC BGA Pin Assignment

The PowerPC name is a trademark of IBM Corp., used under license therefrom.

This document contains information on a new product. Specifications and information herein are subject to change without notice.

REV 1
7/30/97

MCM72FB8ML

MCM72PB8ML

MULTICHIP MODULE
PBGA
CASE 1103B-01

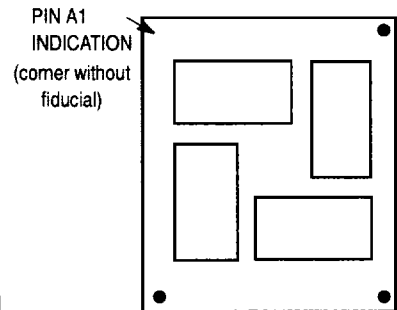
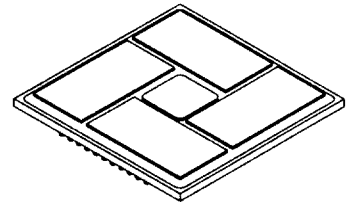

TOP VIEW

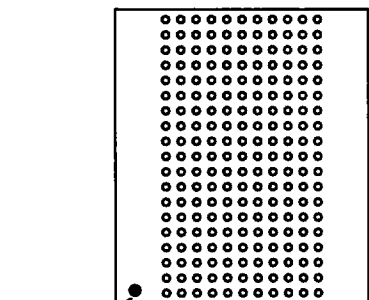

BOTTOM VIEW

(Drawings Not to Scale)



256K X 72 FOUR-CHIP MODULE BLOCK DIAGRAM

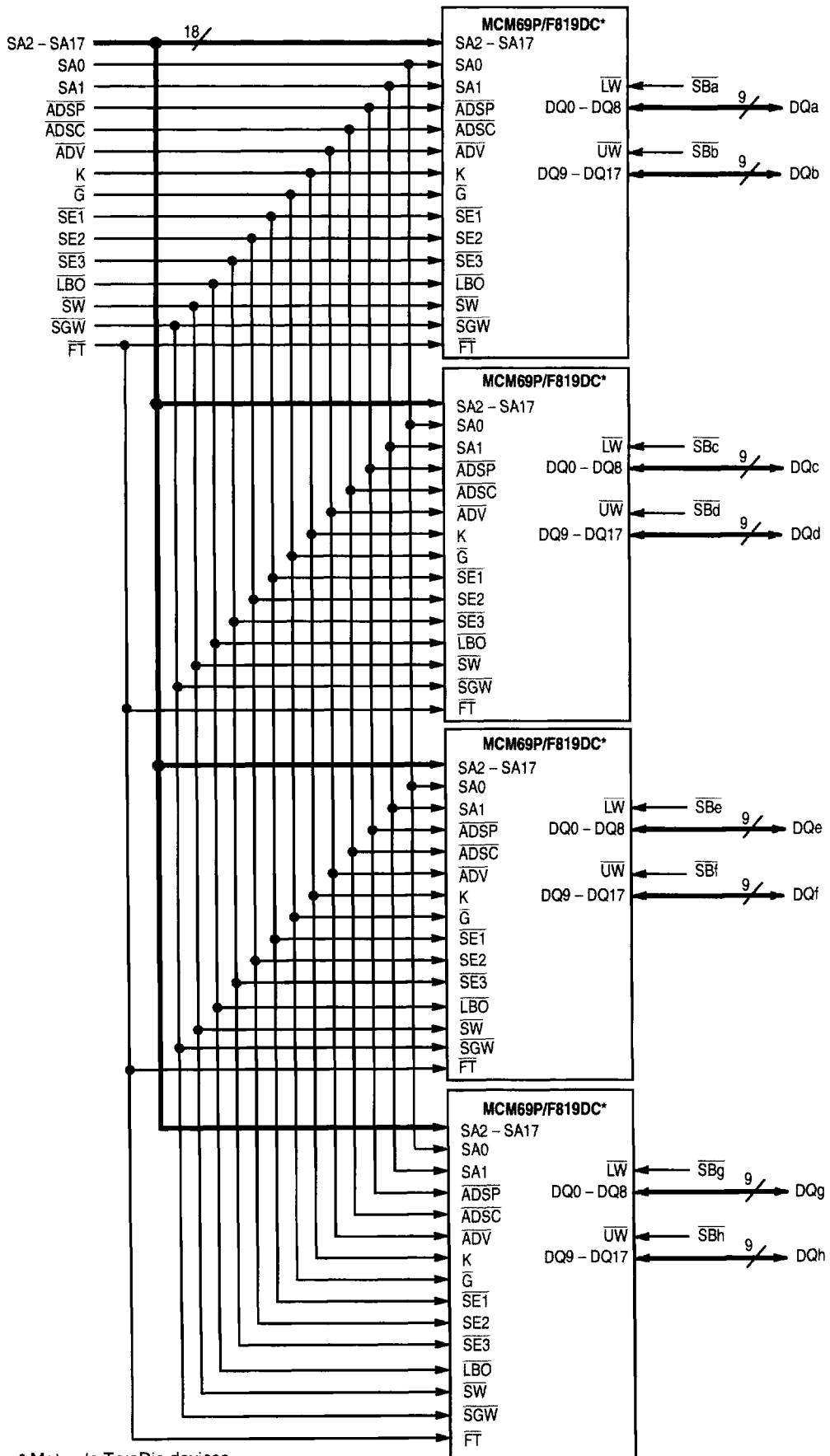

* Motorola TrueDie devices.

PIN ASSIGNMENT

	5	6	7	8	9	10	11	12	13	14	15
A	○ DQe	○ DQe	○ SA	○ SA	○ SA	○ SE1	○ SA	○ SA	○ SA	○ DQd	○ DQd
B	○ DQe	○ DQe	○ SA	○ SA	○ SA	○ G	○ SA	○ SA	○ SA	○ DQd	○ DQd
C	○ DQe	○ DQe	○ SE2	○ VDDQ	○ VDDQ	○ SGW	○ VDDQ	○ VDDQ	○ SE3	○ DQd	○ DQd
D	○ DQe	○ DQe	○ VDDQ	○ VDD	○ VSS	○ ADV	○ VSS	○ VDD	○ VDDQ	○ DQd	○ DQd
E	○ DQe	○ DQf	○ VDDQ	○ VDD	○ VSS	○ ADSC	○ VSS	○ VDD	○ VDDQ	○ DQc	○ DQd
F	○ DQf	○ DQf	○ VDDQ	○ VDD	○ VSS	○ ADSP	○ VSS	○ VDD	○ VDDQ	○ DQc	○ DQc
G	○ DQf	○ DQf	○ VDDQ	○ VDD	○ VSS	○ VSS	○ VSS	○ VDD	○ VDDQ	○ DQc	○ DQc
H	○ DQf	○ DQf	○ VDDQ	○ VSS	○ VSS	○ VSS	○ VSS	○ VSS	○ VDDQ	○ DQc	○ DQc
J	○ DQf	○ DQf	○ SBe	○ VSS	○ VSS	○ VSS	○ VSS	○ VSS	○ SBd	○ DQc	○ DQc
K	○ SBf	○ SBg	○ NC	○ VSS	○ VSS	○ VSS	○ VSS	○ VSS	○ NC	○ SBb	○ SBc
L	○ DQg	○ DQg	○ SBh	○ VSS	○ VSS	○ VSS	○ VSS	○ VSS	○ SBa	○ DQb	○ DQb
M	○ DQg	○ DQg	○ VDDQ	○ VSS	○ VSS	○ VSS	○ VSS	○ VSS	○ VDDQ	○ DQb	○ DQb
N	○ DQg	○ DQg	○ VDDQ	○ VDD	○ VSS	○ VSS	○ VSS	○ VDD	○ VDDQ	○ DQb	○ DQb
P	○ DQg	○ DQg	○ VDDQ	○ VDD	○ VSS	○ NC	○ VSS	○ VDD	○ VDDQ	○ DQb	○ DQb
R	○ DQg	○ DQh	○ VDDQ	○ VDD	○ VSS	○ K	○ VSS	○ VDD	○ VDDQ	○ DQa	○ DQb
T	○ DQh	○ DQh	○ VDDQ	○ VDD	○ VSS	○ SW	○ VSS	○ VDD	○ VDDQ	○ DQa	○ DQa
U	○ DQh	○ DQh	○ LBO	○ VDDQ	○ VDDQ	○ SA1	○ VDDQ	○ VDDQ	○ FT	○ DQa	○ DQa
V	○ DQh	○ DQh	○ NC	○ SA	○ SA	○ SA0	○ SA	○ SA	○ NC	○ DQa	○ DQa
W	○ DQh	○ DQh	○ NC	○ NC	○ NC	○ NC	○ NC	○ NC	○ NC	○ DQa	○ DQa

**TOP VIEW
256K X 72 JEDEC FOUR-CHIP MODULE
209 BUMP PBGA**

Not to Scale

PIN DESCRIPTIONS

Pin Locations	Symbol	Type	Description
E10	$\overline{\text{ADSC}}$	Input	Synchronous Address Status Controller: Active low, interrupts any ongoing burst and latches a new external address. Used to initiate READ, WRITE, or chip deselect cycle.
F10	$\overline{\text{ADSP}}$	Input	Synchronous Address Status Processor: Active low, interrupts any ongoing burst and latches a new external address. Used to initiate READ, WRITE, or chip deselect cycle (exception — chip deselect does not occur when ADSP is asserted and SE1 is high).
D10	$\overline{\text{ADV}}$	Input	Synchronous Address Advance: Increments address count in accordance with counter type selected (linear/interleaved).
(a) R14, T14, T15, U14, U15, V14, V15, W14, W15 (b) L14, L15, M14, M15, N14, N15, P14, P15, R15 (c) E14, F14, F15, G14, G15, H14, H15, J14, J15 (d) A14, A15, B14, B15, C14, C15, D14, D15, E15 (e) A5, A6, B5, B6, C5, C6, D5, D6, E5 (f) E6, F5, F6, G5, G6, H5, H6, J5, J6 (g) L5, L6, M5, M6, N5, N6, P5, P6, R5 (h) R6, T5, T6, U5, U6, V5, V6, W5, W6	DQx	I/O	Synchronous Data I/O: "x" refers to the byte being read or written (byte a, b, c, d, e, f, g, h).
U13	FT	Input	Flow-Through Input: This pin must remain in steady state (this signal is not registered or latched). It must be tied high or low. Low — flow-through mode. High — pipeline mode.
B10	$\overline{\text{G}}$	Input	Asynchronous Output Enable.
R10	K	Input	Clock: This signal registers the address, data in, and all control signals except $\overline{\text{G}}$, LBO, and FT.
U7	$\overline{\text{LBO}}$	Input	Linear Burst Order Input: This pin must remain in steady state (this signal not registered or latched). It must be tied high or low. Low — linear burst counter (68K/PowerPC). High — interleaved burst counter (486/960/Pentium).
U10, V10	SA1, SA0	Input	Synchronous Address Inputs: These pins must be wired to the two LSBs of the address bus for proper burst operation. These inputs are registered and must meet setup and hold times.
A7, A8, A9, A11, A12, A13, B7, B8, B9, B11, B12, B13, V8, V9, V11, V12	SA2 – SA17	Input	Synchronous Address Inputs: These inputs are registered and must meet setup and hold times.
L13, K14, K15, J13, J7, K5, K6, L7 (a) (b) (c) (d) (e) (f) (g) (h)	$\overline{\text{SBx}}$	Input	Synchronous Byte Write Inputs: "x" refers to the byte being written (byte a, b, c, d, e, f, g, h). $\overline{\text{SGW}}$ overrides $\overline{\text{SBx}}$.
A10	SE1	Input	Synchronous Chip Enable: Active low to enable chip. Negated high—blocks $\overline{\text{ADSP}}$ or deselects chip when $\overline{\text{ADSC}}$ is asserted.
C7	SE2	Input	Synchronous Chip Enable: Active high for depth expansion.
C13	SE3	Input	Synchronous Chip Enable: Active low for depth expansion.
C10	$\overline{\text{SGW}}$	Input	Synchronous Global Write: This signal writes all bytes regardless of the status of the $\overline{\text{SBx}}$ and $\overline{\text{SW}}$ signals. If only byte write signals $\overline{\text{SBx}}$ are being used, tie this pin high.
T10	$\overline{\text{SW}}$	Input	Synchronous Write: This signal writes only those bytes that have been selected using the byte write $\overline{\text{SBx}}$ pins. If only byte write signals $\overline{\text{SBx}}$ are being used, tie this pin low.
D8, D12, E8, E12, F8, F12, G8, G12, N8, N12, P8, P12, R8, R12, T8, T12	VDD	Supply	Core Power Supply.
C8, C9, C11, C12, D7, D13, E7, E13, F7, F13, G7, G13, H7, H13, M7, M13, N7, N13, P7, P13, R7, R13, T7, T13, U8, U9, U11, U12	VDDQ	Supply	I/O Power Supply.

PIN DESCRIPTIONS (continued)

Pin Locations	Symbol	Type	Description
D9, D11, E9, E11, F9, F11, G9 – G11, H8 – H12, J8 – J12, K8 – K12, L8 – L12, M8 – M12, N9 – N11, P9, P11, R9, R11, T9, T11	VSS	Supply	Ground.
K7, K13, P10, V7, V13, W7 – W13	NC	—	No Connection: There is no connection to the chip.

TRUTH TABLE (See Notes 1 through 5)

Next Cycle	Address Used	SE1	SE2	SE3	ADSP	ADSC	ADV	G ³	DQx	Write 2, 4
Deselect	None	1	X	X	X	0	X	X	High-Z	X
Deselect	None	0	X	1	0	X	X	X	High-Z	X
Deselect	None	0	0	X	0	X	X	X	High-Z	X
Deselect	None	X	X	1	1	0	X	X	High-Z	X
Deselect	None	X	0	X	1	0	X	X	High-Z	X
Begin Read	External	0	1	0	0	X	X	X	High-Z	X ⁵
Begin Read	External	0	1	0	1	0	X	X	High-Z	READ ⁵
Continue Read	Next	X	X	X	1	1	0	1	High-Z	READ
Continue Read	Next	X	X	X	1	1	0	0	DQ	READ
Continue Read	Next	1	X	X	X	1	0	1	High-Z	READ
Continue Read	Next	1	X	X	X	1	0	0	DQ	READ
Suspend Read	Current	X	X	X	1	1	1	1	High-Z	READ
Suspend Read	Current	X	X	X	1	1	1	0	DQ	READ
Suspend Read	Current	1	X	X	X	1	1	1	High-Z	READ
Suspend Read	Current	1	X	X	X	1	1	0	DQ	READ
Begin Write	External	0	1	0	1	0	X	X	High-Z	WRITE
Continue Write	Next	X	X	X	1	1	0	X	High-Z	WRITE
Continue Write	Next	1	X	X	X	1	0	X	High-Z	WRITE
Suspend Write	Current	X	X	X	1	1	1	X	High-Z	WRITE
Suspend Write	Current	1	X	X	X	1	1	X	High-Z	WRITE

NOTES:

1. X = Don't Care. 1 = logic high. 0 = logic low.
2. Write is defined as either 1) any SBx and SW low or 2) SGW is low.
3. G³ is an asynchronous signal and is not sampled by the clock K. G³ drives the bus immediately (tGLQX) following G³ going low.
4. On write cycles that follow read cycles, G³ must be negated prior to the start of the write cycle to ensure proper write data setup times. G³ must also remain negated at the completion of the write cycle to ensure proper write data hold times.
5. This read assumes the RAM was previously deselected.

LINEAR BURST ADDRESS TABLE (LBO = VSS)

1st Address (External)	2nd Address (Internal)	3rd Address (Internal)	4th Address (Internal)
X ... X00	X ... X01	X ... X10	X ... X11
X ... X01	X ... X10	X ... X11	X ... X00
X ... X10	X ... X11	X ... X00	X ... X01
X ... X11	X ... X00	X ... X01	X ... X10

INTERLEAVED BURST ADDRESS TABLE (LBO = VDD)

1st Address (External)	2nd Address (Internal)	3rd Address (Internal)	4th Address (Internal)
X ... X00	X ... X01	X ... X10	X ... X11
X ... X01	X ... X00	X ... X11	X ... X10
X ... X10	X ... X11	X ... X00	X ... X01
X ... X11	X ... X10	X ... X01	X ... X00

WRITE TRUTH TABLE

Cycle Type	SGW	SW	SBa	SBb	SBc	SBd	SBe	SBf	SBg	SBh
Read	H	H	X	X	X	X	X	X	X	X
Read	H	L	L	H	H	H	H	H	H	H
Write Byte a	H	L	L	H	H	H	H	H	H	H
Write Byte b	H	L	H	L	H	H	H	H	H	H
Write Byte c	H	L	H	H	L	H	H	H	H	H
Write Byte d	H	L	H	H	H	L	H	H	H	H
Write Byte e	H	L	H	H	H	H	L	H	H	H
Write Byte f	H	L	H	H	H	H	H	L	H	H
Write Byte g	H	L	H	H	H	H	H	H	L	H
Write Byte h	H	L	H	H	H	H	H	H	H	L
Write All Bytes	H	L	L	L	L	L	L	L	L	L
Write All Bytes	L	X	X	X	X	X	X	X	X	X

ABSOLUTE MAXIMUM RATINGS (See Note 1)

Rating	Symbol	Value	Unit	Notes
Power Supply Voltage	V_{DD}	$V_{SS} - 0.5$ to $+4.6$	V	
I/O Supply Voltage	V_{DDQ}	$V_{SS} - 0.5$ to V_{DD}	V	2
Input Voltage Relative to V_{SS} for Any Pin Except V_{DD}	V_{in}, V_{out}	$V_{SS} - 0.5$ to $V_{DD} + 0.5$	V	2
Input Voltage (Three-State I/O)	V_{IT}	$V_{SS} - 0.5$ to $V_{DDQ} + 0.5$	V	2
Output Current (per I/O)	I_{out}	± 20	mA	
Package Power Dissipation	P_D	6.4	W	3
Ambient Temperature	T_A	0 to 70	$^{\circ}\text{C}$	
Die Temperature	T_J	110	$^{\circ}\text{C}$	3
Temperature Under Bias	T_{bias}	-10 to 85	$^{\circ}\text{C}$	
Storage Temperature	T_{stg}	-55 to 125	$^{\circ}\text{C}$	

This device contains circuitry to protect the inputs against damage due to high static voltages or electric fields; however, it is advised that normal precautions be taken to avoid application of any voltage higher than maximum rated voltages to this high-impedance circuit.

NOTES:

1. Permanent device damage may occur if ABSOLUTE MAXIMUM RATINGS are exceeded. Functional operation should be restricted to RECOMMENDED OPERATING CONDITIONS. Exposure to higher than recommended voltages for extended periods of time could affect device reliability.
2. This is a steady-state DC parameter that is in effect after the power supply has achieved its nominal operating level. Power sequencing is not necessary.
3. Power dissipation capability is dependent upon package characteristics and use environment. See Package Thermal Characteristics.

PACKAGE THERMAL CHARACTERISTICS

Thermal Resistance	Symbol	Max	Unit	Notes
Junction to Ambient (@ 200 lfm)	$R_{\theta JA}$	19 13	$^{\circ}\text{C/W}$	1, 2
Junction to Board (Bottom)	$R_{\theta JB}$	10	$^{\circ}\text{C/W}$	3
Junction to Case (Top)	$R_{\theta JC}$	0.3	$^{\circ}\text{C/W}$	4

NOTES:

1. Junction temperature is a function of on-chip power dissipation, package thermal resistance, mounting site (board) temperature, ambient temperature, air flow, board population, and board thermal resistance.
2. Per SEMI G38-87.
3. Indicates the average thermal resistance between the die and the printed circuit board.
4. Indicates the average thermal resistance between the die and the case top surface via the cold plate method (MIL SPEC-883 Method 1012.1).

DC OPERATING CONDITIONS AND CHARACTERISTICS
 ($V_{DD} = 3.3\text{ V} + 10\%, -5\%$, $T_A = 0\text{ to }70^\circ\text{C}$, Unless Otherwise Noted)

RECOMMENDED OPERATING CONDITIONS: 2.5 V I/O SUPPLY (Voltages Referenced to $V_{SS} = 0\text{ V}$)

Parameter	Symbol	Min	Typ	Max	Unit
Supply Voltage	V_{DD}	3.135	3.3	3.465	V
I/O Supply Voltage	V_{DDQ}	2.375	2.5	2.9	V
Input Low Voltage	V_{IL}	-0.3	—	0.7	V
Input High Voltage	V_{IH}	1.7	—	$V_{DD} + 0.3$	V
Input High Voltage I/O Pins	V_{IH2}	1.7	—	$V_{DDQ} + 0.3$	V

RECOMMENDED OPERATING CONDITIONS: 3.3 V I/O SUPPLY (Voltages Referenced to $V_{SS} = 0\text{ V}$)

Parameter	Symbol	Min	Typ	Max	Unit
Supply Voltage	V_{DD}	3.135	3.3	3.465	V
I/O Supply Voltage	V_{DDQ}	3.135	3.3	V_{DD}	V
Input Low Voltage	V_{IL}	-0.5	—	0.8	V
Input High Voltage	V_{IH}	2	—	$V_{DD} + 0.5$	V
Input High Voltage I/O Pins	V_{IH2}	2	—	$V_{DDQ} + 0.5$	V

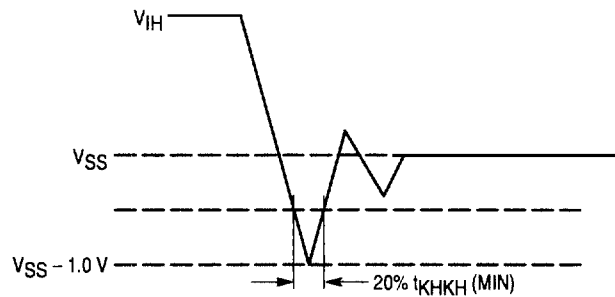

Figure 1. Undershoot Voltage

DC CHARACTERISTICS AND SUPPLY CURRENTS

Parameter	Symbol	Min	Typ	Max	Unit	Notes
Input Leakage Current ($0\text{ V} \leq V_{in} \leq V_{DD}$)	$I_{kg(I)}$	—	—	± 1	μA	
Output Leakage Current ($0\text{ V} \leq V_{in} \leq V_{DDQ}$)	$I_{kg(O)}$	—	—	± 1	μA	
AC Supply Current (Device Selected, All Outputs Open, Freq = Max, $V_{DD} = \text{Max}$, $V_{DDQ} = \text{Max}$) Includes Supply Current from Both V_{DD} and V_{DDQ}	I_{DDA}	—	—	1700	mA	1, 2, 3
CMOS Standby Supply Current (Device Deselected, Freq = 0, $V_{DD} = \text{Max}$, $V_{DDQ} = \text{Max}$, All Inputs Static at CMOS Levels)	I_{SB2}	—	—	TBD	mA	4, 5
TTL Standby Supply Current (Device Deselected, Freq = 0, $V_{DD} = \text{Max}$, $V_{DDQ} = \text{Max}$, All Inputs Static at TTL Levels)	I_{SB3}	—	—	TBD	mA	4, 6
Clock Running (Device Deselected, Freq = Max, $V_{DD} = \text{Max}$, $V_{DDQ} = \text{Max}$, All Inputs Toggling at CMOS Levels)	I_{SB4}	—	—	TBD	mA	4, 5
Static Clock Running (Device Deselected, Freq = Max, $V_{DD} = \text{Max}$, $V_{DDQ} = \text{Max}$, All Inputs Static at TTL Levels)	I_{SB5}	—	—	TBD	mA	4, 6
Output Low Voltage ($I_{OL} = 2\text{ mA}$) $V_{DDQ} = 2.5\text{ V}$	V_{OL1}	—	—	0.7	V	
Output High Voltage ($I_{OH} = -2\text{ mA}$) $V_{DDQ} = 2.5\text{ V}$	V_{OH1}	1.7	—	—	V	
Output Low Voltage ($I_{OL} = 8\text{ mA}$) $V_{DDQ} = 3.3\text{ V}$	V_{OL2}	—	—	0.4	V	
Output High Voltage ($I_{OH} = -4\text{ mA}$) $V_{DDQ} = 3.3\text{ V}$	V_{OH2}	2.4	—	—	V	

NOTES:

- Reference AC Operating Conditions and Characteristics for input and timing.
- All addresses transition simultaneously low (LSB) then high (MSB).
- Data states are all zero.
- Device is deselected as defined by the Truth Table.
- CMOS levels for I/O's are $V_{IT} \leq V_{SS} + 0.2\text{ V}$ or $\geq V_{DDQ} - 0.2\text{ V}$. CMOS levels for other inputs are $V_{in} \leq V_{SS} + 0.2\text{ V}$ or $\geq V_{DD} - 0.2\text{ V}$.
- TTL levels for I/O's are $V_{IT} \leq V_{IL}$ or $\geq V_{IH2}$. TTL levels for other inputs are $V_{in} \leq V_{IL}$ or $\geq V_{IH}$.

CAPACITANCE ($f = 1.0\text{ MHz}$, $dV = 3.0\text{ V}$, $T_A = 0$ to 70°C , Periodically Sampled Rather Than 100% Tested)

Parameter	Symbol	Min	Typ	Max	Unit
Input Capacitance	C_{in}	—	—	16	pF
Input/Output Capacitance	$C_{I/O}$	—	—	5	pF

AC OPERATING CONDITIONS AND CHARACTERISTICS

(V_{DD} = 3.3 V + 10%, - 5%, T_A = 0 to 70°C, Unless Otherwise Noted)

Input Timing Measurement Reference Level 1.25 V
 Input Pulse Levels 0 to 2.5 V
 Input Rise/Fall Time (See Figure 3) 1.0 V/ns (20 to 80%)

Output Timing Reference Level 1.25 V
 Output Load See Figure 2 Unless Otherwise Noted

READ/WRITE CYCLE TIMING (See Notes 1 and 2)

Parameter	Symbol	Pipeline MCM72PB8ML3.5 166 MHz		Pipeline MCM72PB8ML4 133 MHz		Flow-Through MCM72FB8ML7.5 117 MHz		Flow-Through MCM72FB8ML8 100 MHz		Unit	Notes
		Min	Max	Min	Max	Min	Max	Min	Max		
Cycle Time	t _{KHKH}	6	—	7.5	—	8.5	—	10	—	ns	
Clock High Pulse Width	t _{KHKL}	2.4	—	3	—	3.4	—	4	—	ns	3
Clock Low Pulse Width	t _{KLKH}	2.4	—	3	—	3.4	—	4	—	ns	3
Clock Access Time	t _{KHQV}	—	3.5	—	4	—	7.5	—	8	ns	
Output Enable to Output Valid	t _{GLQV}	—	3.5	—	3.8	—	3.5	—	3.5	ns	
Clock High to Output Active	t _{KHQX1}	0	—	0	—	0	—	0	—	ns	4, 5
Clock High to Output Change	t _{KHQX2}	1.5	—	1.5	—	2	—	2	—	ns	4
Output Enable to Output Active	t _{GLQX}	0	—	0	—	0	—	0	—	ns	4, 5
Output Disable to Q High-Z	t _{GHQZ}	—	3.5	—	3.8	—	3.5	—	3.5	ns	4, 5
Clock High to Q High-Z	t _{KHQZ}	1.5	6	1.5	7.5	2	3.5	2	3.5	ns	4, 5
Setup Times: Address ADSP, ADSC, ADV Data In Write Chip Enable	t _{ADKH} t _{ADSKH} t _{DVKH} t _{WVKH} t _{EVKH}	1.5	—	1.5	—	2	—	2	—	ns	
Hold Times: Address ADSP, ADSC, ADV Data In Write Chip Enable	t _{KHAX} t _{KHADSX} t _{KHDX} t _{KHWX} t _{KHEX}	0.5	—	0.5	—	0.5	—	0.5	—	ns	

NOTES:

- Write is defined as either any \overline{SBx} and \overline{SW} low or \overline{SGW} is low. Chip Enable is defined as $\overline{SE1}$ low, SE2 high, and $\overline{SE3}$ low whenever \overline{ADSP} or \overline{ADSC} is asserted.
- All read and write cycle timings are referenced from K or \overline{G} .
- In order to reduce test correlation issues and to reduce the effects of application specific input edge rate variations on correlation between data sheet parameters and actual system performance, FSRAM AC parametric specifications are always specified at V_{DDQ}/2. In some design exercises, it is desirable to evaluate timing using other reference levels. Since the maximum test input edge rate is known and is given in the AC Test Conditions section of the data sheet as 1 V/ns, one can easily interpolate timing values to other reference levels.
- This parameter is sampled and not 100% tested.
- Measured at ± 200 mV from steady state.

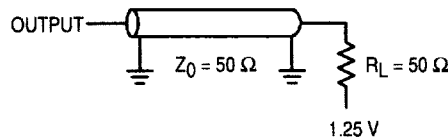
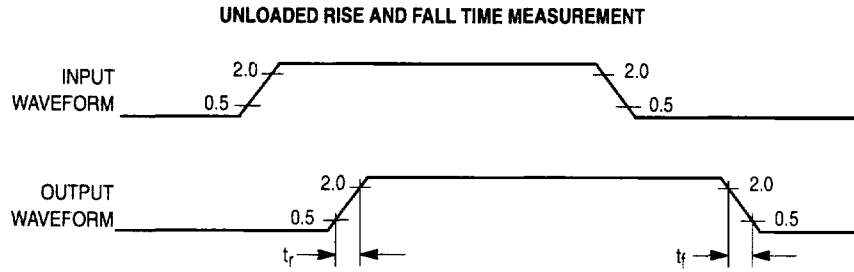
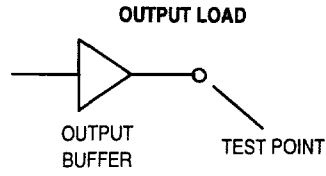

Figure 2. AC Test Load



NOTES:

1. Input waveform has a slew rate of 1 V/ns.
2. Rise time t_r is measured from 0.5 to 2.0 V unloaded.
3. Fall time t_f is measured from 2.0 to 0.5 V unloaded.

Figure 3. Unloaded Rise and Fall Time Characterization

PULL-UP		
VOLTAGE (V)	I (mA) MIN	I (mA) MAX
-0.5	-38	-105
0	-38	-105
0.8	-38	-105
1.25	-26	-83
1.5	-20	-70
2.3	0	-30
2.7	0	-10
2.9	0	0

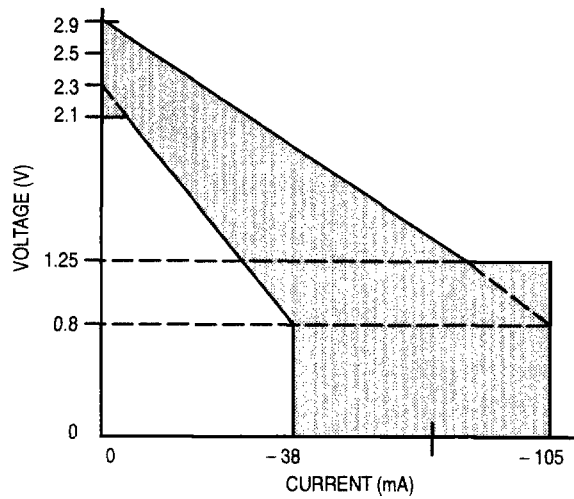

(a) Pull-Up for 2.5 V I/O Supply

PULL-UP		
VOLTAGE (V)	I (mA) MIN	I (mA) MAX
-0.5	-50	-150
0	-50	-150
1.4	-50	-150
1.65	-46	-130
2.0	-35	-101
3.135	0	-25
3.6	0	0

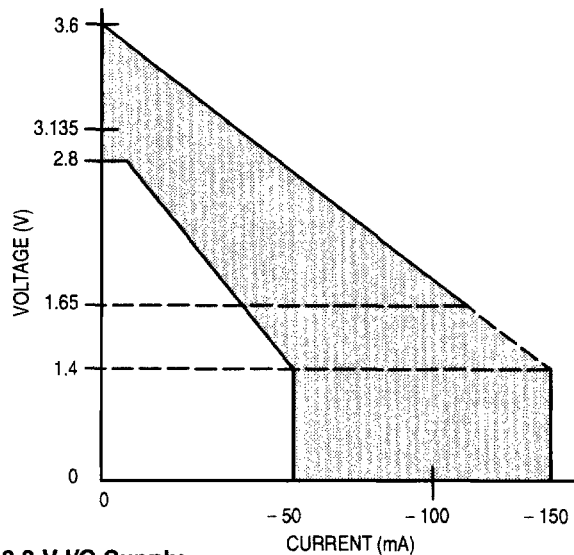

(b) Pull-Up for 3.3 V I/O Supply

PULL-DOWN		
VOLTAGE (V)	I (mA) MIN	I (mA) MAX
-0.5	0	0
0	0	0
0.4	10	20
0.8	20	40
1.25	31	63
1.6	40	80
2.8	40	80
3.2	40	80
3.4	40	80

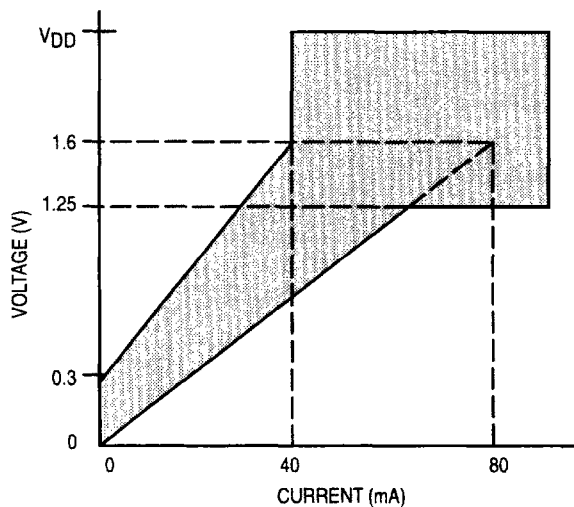

(c) Pull-Down

Figure 4. Typical Output Buffer Characteristics

MCM72PB8ML PIPELINE READ/WRITE CYCLES

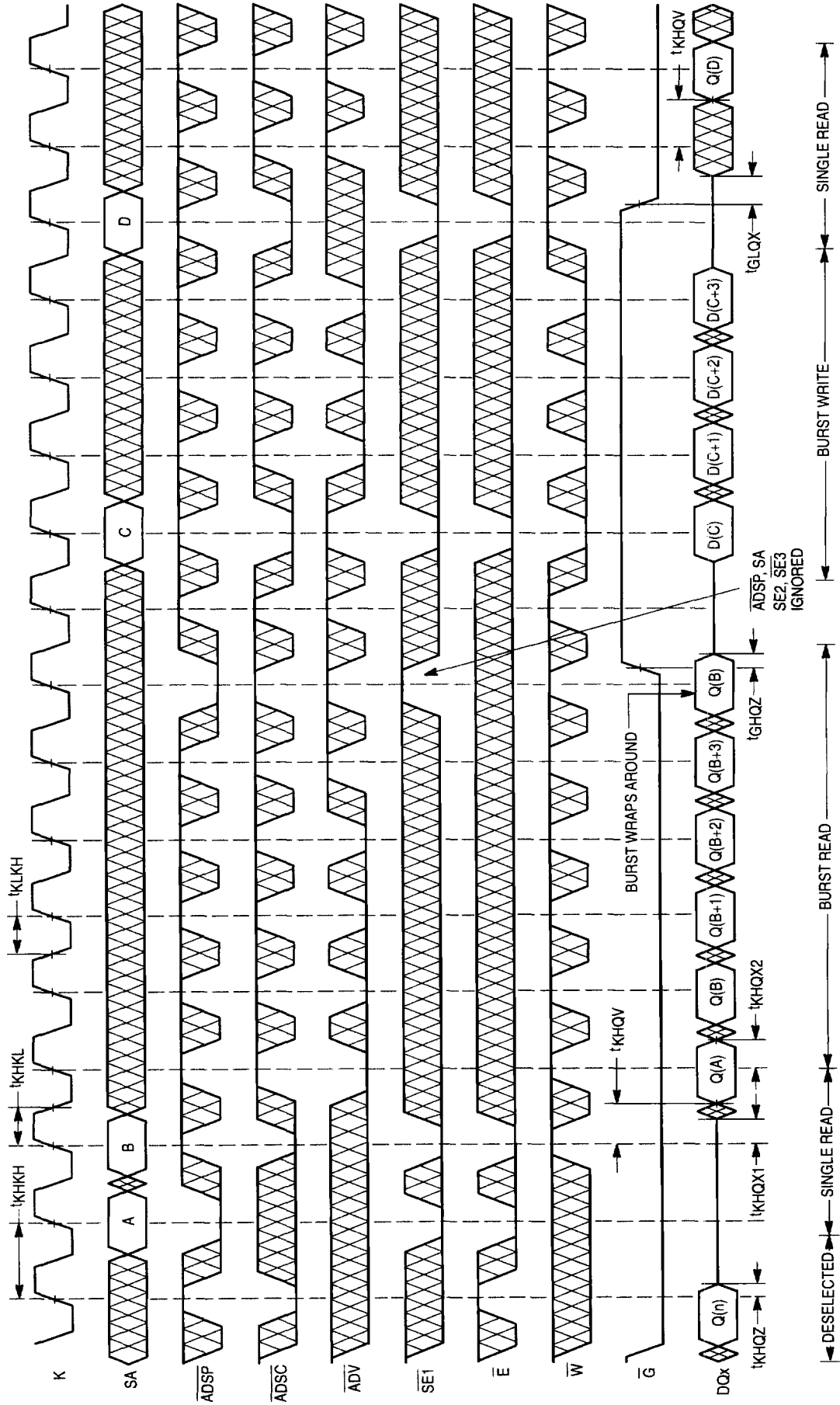

NOTE: \bar{E} low = SE2 high and SE3 low.
 \bar{W} low = SGW low and/or SW and SBx low.

MCM72FB8ML FLOW-THROUGH READ/WRITE CYCLES

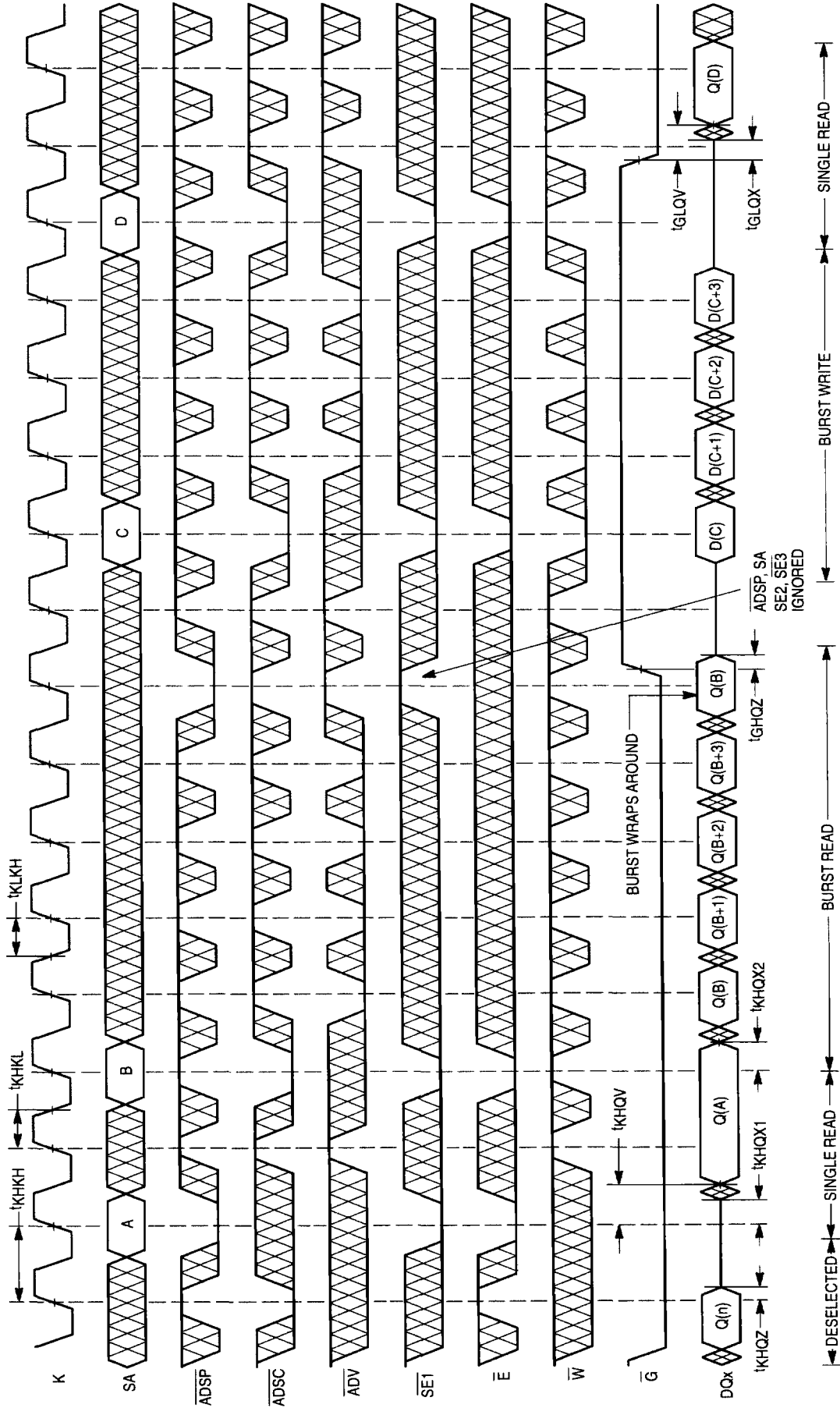

NOTE: \bar{E} low = SE2 high and SE3 low.
 \bar{W} low = SGW low and/or SW and SBx low.

APPLICATION INFORMATION

STOP CLOCK OPERATION

In the stop clock mode of operation, the SRAM will hold all state and data values even though the clock is not running (full static operation). The SRAM design allows the clock to start with $\overline{\text{ADSP}}$ and $\overline{\text{ADSC}}$, and stops the clock after the last write data is latched, or the last read data is driven out.

When starting and stopping the clock, the AC clock timing and parametrics must be strictly maintained. For example,

clock pulse width and edge rates must be guaranteed when starting and stopping the clocks.

To achieve the lowest power operation for all three stop clock modes, stop read, stop write, and stop deselect:

1. Force the clock to a low state.
2. Force the control signals to an inactive state (this guarantees any potential source of noise on the clock input will not start an unplanned on activity).
3. Force the address inputs to a low state.

MCM72PB8ML PIPELINE STOP CLOCK WITH READ TIMING

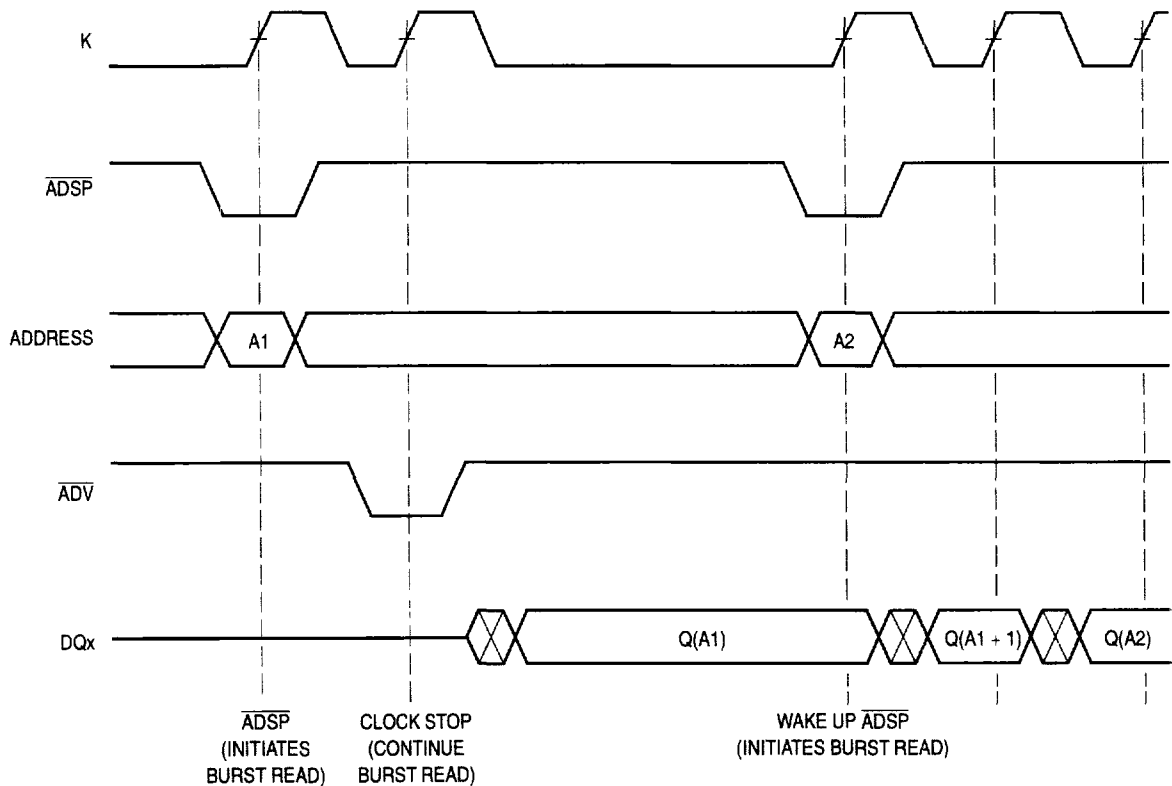

NOTE: For lowest possible power consumption during stop clock, the addresses should be driven to a low state (V_{IL}). Best results are obtained if $V_{IL} < 0.2$ V.

MCM72FB8ML FLOW-THROUGH STOP CLOCK WITH READ TIMING

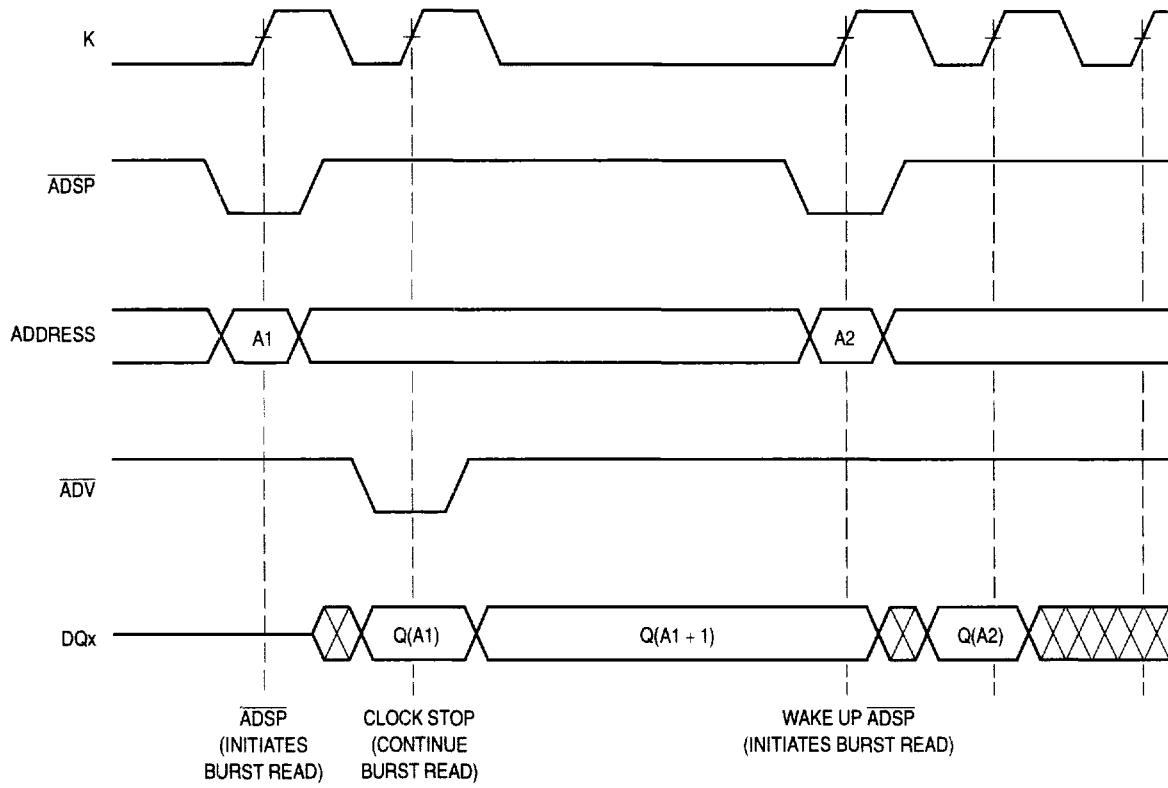

NOTE: For lowest possible power consumption during stop clock, the addresses should be driven to a low state (V_{IL}). Best results are obtained if $V_{IL} < 0.2$ V.

STOP CLOCK WITH WRITE TIMING

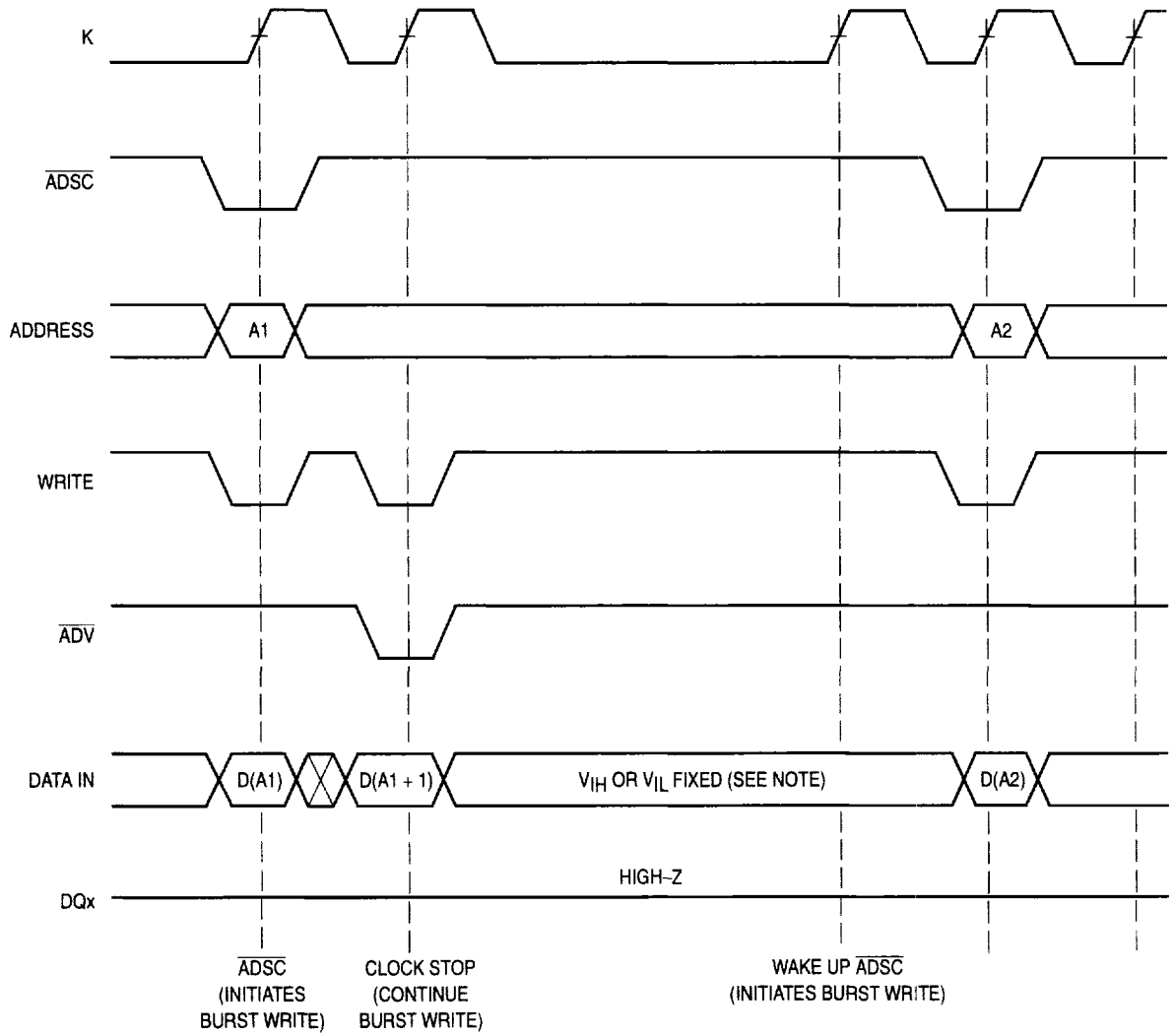

NOTE: While the clock is stopped, DATA IN must be fixed in a high (V_{IH}) or low (V_{IL}) state to reduce the DC current of the input buffers. For lowest power operation, all data and address lines should be held in a low (V_{IL}) state and control lines held in an inactive state.

STOP CLOCK WITH DESELECT OPERATION TIMING

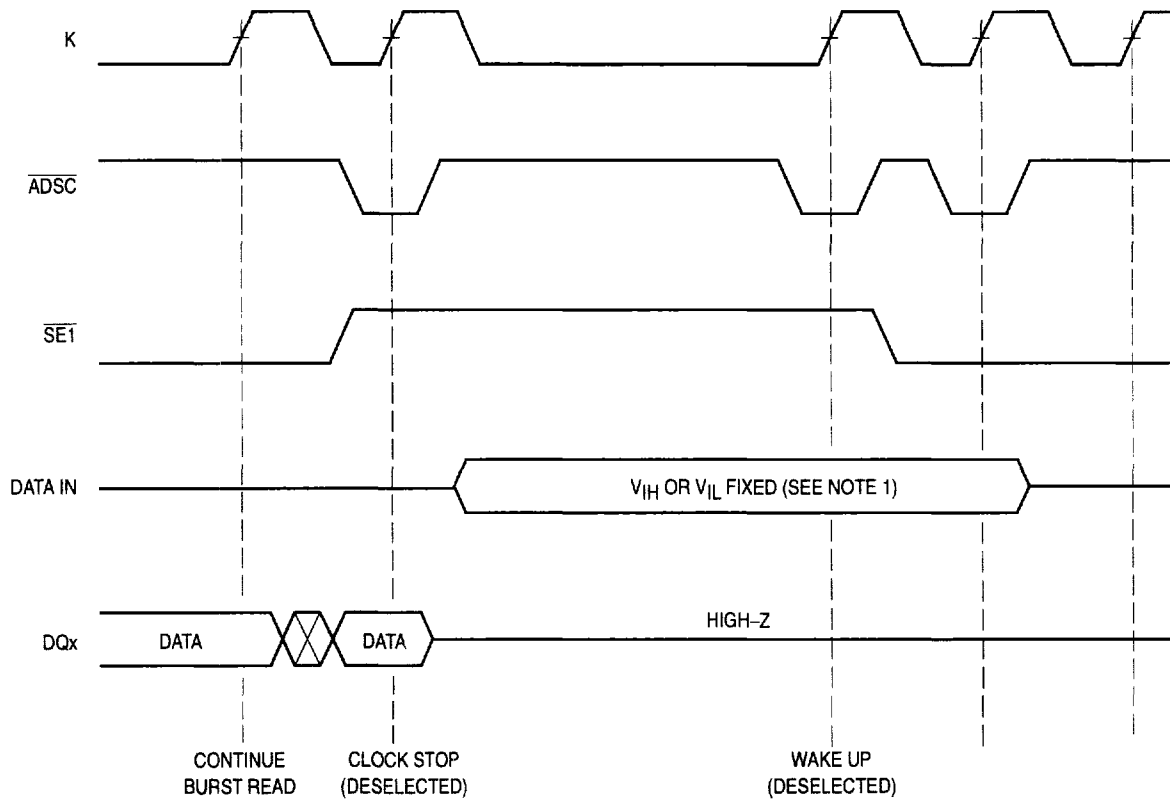

NOTES:

1. While the clock is stopped, DATA IN must be fixed in a high (V_{IH}) or low (V_{IL}) state to reduce the DC current of the input buffers. For lowest power operation, all data and address lines should be held in a low (V_{IL}) state and control lines held in an inactive state.
2. For best possible power savings, the data-in should be driven low.

NON-BURST SYNCHRONOUS OPERATION

Although this BurstRAM has been designed for PowerPC-based and other high end MPU-based systems, these SRAMs can be used in other high speed L2 cache or memory applications that do not require the burst address feature. Most L2 caches designed with a synchronous interface can make use of the MCM72FB8ML or MCM72PB8ML. The burst counter feature of the BurstRAM can be disabled, and the SRAM can be configured to act upon a continuous stream of addresses. See Figures 5 and 6.

CONTROL PIN TIE VALUES ($H \geq V_{IH}$, $L \leq V_{IL}$)

Non-Burst	ADSP	ADSC	ADV	SE1	LBO
Sync Non-Burst, Pipelined SRAM	H	L	H	L	X

NOTE: Although X is specified in the table as a don't care, the pin must be tied either high or low.

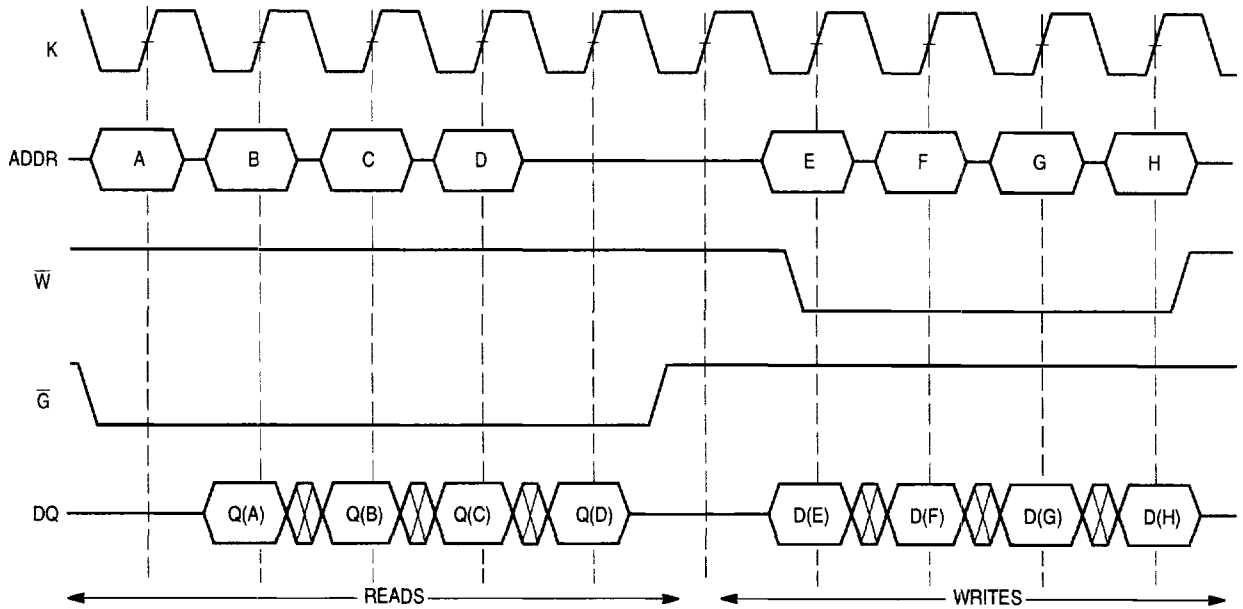

Figure 5. Configured as Non-Burst Synchronous Flow-Through SRAM

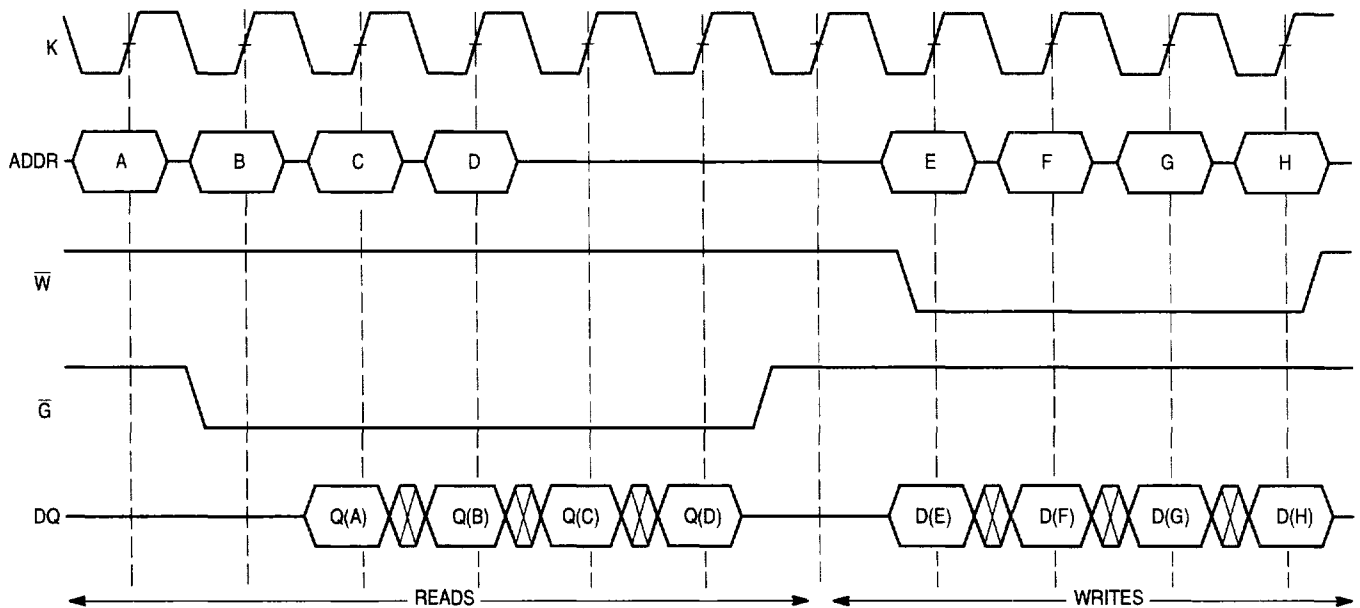
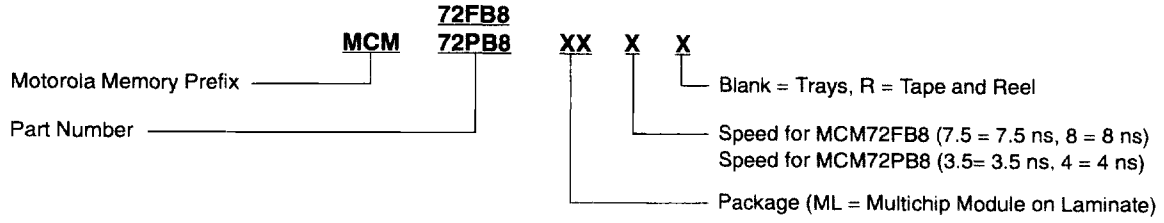

Figure 6. Configured as Non-Burst Synchronous Pipelined SRAM

ORDERING INFORMATION (Order by Full Part Number)



Full Part Numbers — MCM72FB8ML7.5 MCM72FB8ML8
MCM72FB8ML7.5R MCM72FB8ML8R

MCM72PB8ML3.5 MCM72PB8ML4
MCM72PB8ML3.5R MCM72PB8ML4R

PACKAGE DIMENSIONS

MULTICHIP MODULE PBGA CASE 1103B-01

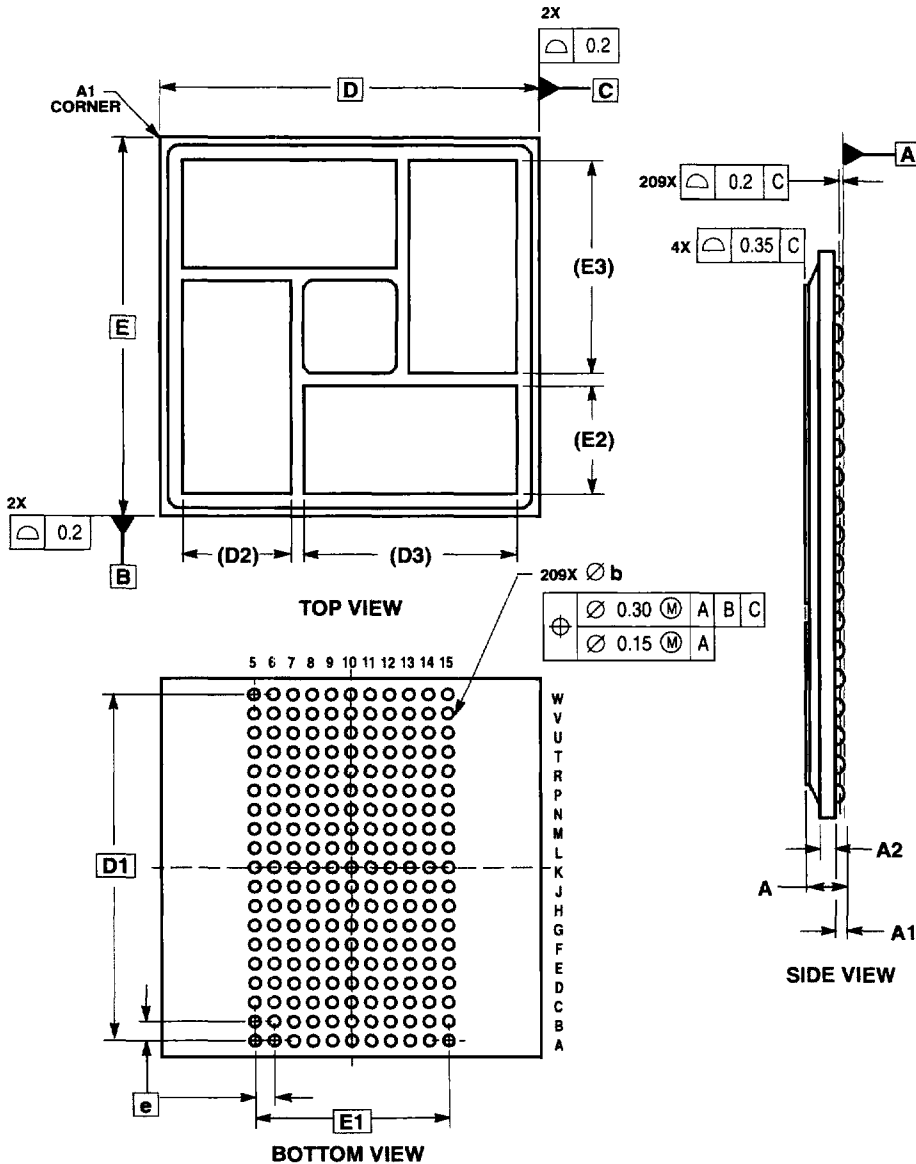

- NOTES:
1. DIMENSIONS AND TOLERANCING PER ASME Y14.5M, 1994.
 2. DIMENSIONS IN MILLIMETERS.
 3. DIMENSION b IS THE MAXIMUM SOLDER BALL DIAMETER MEASURED PARALLEL TO DATUM A.
 4. DIMENSIONS D2, D3, E2, AND E3 ARE FOR INFORMATION ONLY.

MILLIMETERS		
DIM	MIN	MAX
A	2.00	2.90
A1	0.50	0.70
A2	0.80	1.20
b	0.60	0.90
D	25.00 BSC	
D1	22.86 BSC	
D2	7.14 REF	
D3	14.05 REF	
e	1.27 BSC	
E	25.00 BSC	
E1	12.70 BSC	
E2	7.14 REF	
E3	14.05 REF	

Motorola reserves the right to make changes without further notice to any products herein. Motorola makes no warranty, representation or guarantee regarding the suitability of its products for any particular purpose, nor does Motorola assume any liability arising out of the application or use of any product or circuit, and specifically disclaims any and all liability, including without limitation consequential or incidental damages. "Typical" parameters which may be provided in Motorola data sheets and/or specifications can and do vary in different applications and actual performance may vary over time. All operating parameters, including "Typicals" must be validated for each customer application by customer's technical experts. Motorola does not convey any license under its patent rights nor the rights of others. Motorola products are not designed, intended, or authorized for use as components in systems intended for surgical implant into the body, or other applications intended to support or sustain life, or for any other application in which the failure of the Motorola product could create a situation where personal injury or death may occur. Should Buyer purchase or use Motorola products for any such unintended or unauthorized application, Buyer shall indemnify and hold Motorola and its officers, employees, subsidiaries, affiliates, and distributors harmless against all claims, costs, damages, and expenses, and reasonable attorney fees arising out of, directly or indirectly, any claim of personal injury or death associated with such unintended or unauthorized use, even if such claim alleges that Motorola was negligent regarding the design or manufacture of the part. Motorola and  are registered trademarks of Motorola, Inc. Motorola, Inc. is an Equal Opportunity/Affirmative Action Employer.

Mfax is a trademark of Motorola, Inc.

How to reach us:

USA/EUROPE/Locations Not Listed: Motorola Literature Distribution;
P.O. Box 5405, Denver, Colorado 80217. 303-675-2140 or 1-800-441-2447

JAPAN: Nippon Motorola Ltd.: SPD, Strategic Planning Office, 4-32-1,
Nishi-Gotanda, Shinagawa-ku, Tokyo 141, Japan. 81-3-5487-8488

Mfax™: RMFAX0@email.sps.mot.com – TOUCHTONE 602-244-6609
– US & Canada ONLY 1-800-774-1848

ASIA/PACIFIC: Motorola Semiconductors H.K. Ltd.; 8B Tai Ping Industrial Park,
51 Ting Kok Road, Tai Po, N.T., Hong Kong. 852-26629298

INTERNET: <http://motorola.com/sps>



MOTOROLA



MCM72FB8ML/D