

Flasher, 18-mW Shunt

Description

The bipolar integrated circuit, U6043B, is used in relay-controlled automotive flashers where a high level EMC is required.

Lamp outage is indicated by frequency doubling during hazard warning as well as direction mode.

Features

- D Temperature and supply voltage compensated flashing frequency
- D Frequency doubling indicates lamp outage
- D Relay driver output with high current carrying capacity and low saturation voltage

- D Minimum lamp load for flasher operation: ≥ 1 W
- D Very low susceptibility to EMI
- D Protection according to ISO/TR 7637/1 level 4

Ordering Information

Extended Type Number	Package	Remarks
U6043B	DIP8	
U6043B-FP	SO8	

Block Diagram

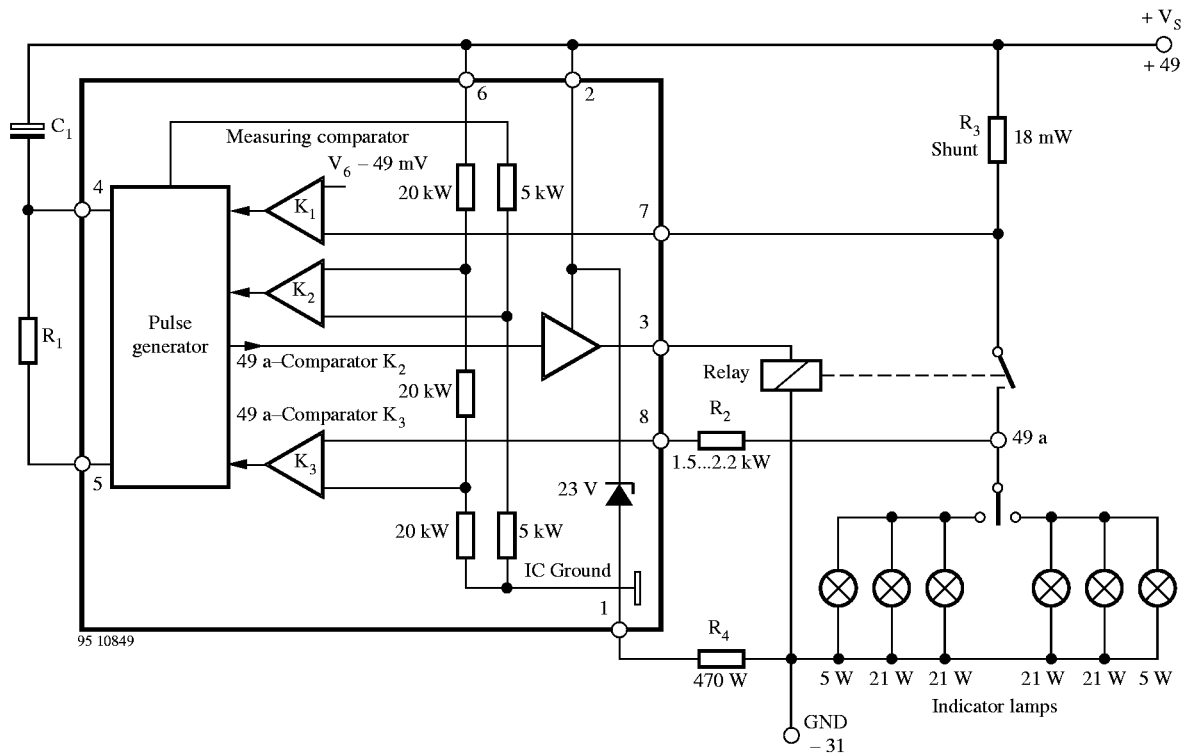
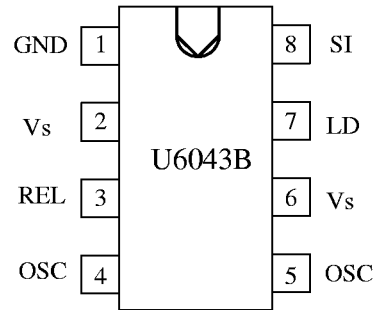

Figure 1. Application circuit as a car flasher

Pin Description

Pin	Symbol	Function
1	GND	IC ground
2	V _S	Supply voltage
3	REL	Relay driver
4	OSC	Oscillator
5	OSC	Oscillator
6	V _S	Supply voltage, Sense
7	LD	Lamp outage detection
8	SI	Start input (49a)



12749

Figure 2. Pinning

Functional Description

Pin 1, GND

The integrated circuit is protected against damage via resistor R₄ to ground (-31) in the case of battery reversal. An integrated protection circuit together with external resistances R₂ and R₄ limits the current pulses in the IC.

Pin 2, Supply voltage, V_S - Power

The arrangement of the supply connections to Pin 2 (and 6) must be so as to ensure that, on the connection printed circuit board (PCB), the resistance of V_S to Pin 6 is lower than that to Pin 2.

Pin 3, Relay control output (driver)

The relay control output is a high-side driver with a low saturation voltage and capable to drive a typical automotive relay with a minimum coil resistance of 60 W.

Pin 4 and 5 Oscillator

Flashing frequency, f₁, is determined by the R₁C₁ components as follows (see figure 1):

$$f_1 \left[\frac{1}{R_1 C_1} \right] 1.5 \text{ Hz}$$

where C₁ 47 nF
R₁ + 6.8 kW to 510 kW

In the case of a lamp outage (see Pin 7) the oscillator frequency is switched to the lamp outage frequency f₂ with f₂ [2.2 f₁.

Duty cycle in normal flashing mode: 50%

Duty cycle in lamp outage mode: 40% (bright phase)

Pin 6, Supply voltage, Sense

For accurate monitoring via the shunt resistor, a minimized layer resistance from point V_S / shunt to Pin 6 is recommended.

Pin 7, Lamp outage detection

The lamp current is monitored via an external shunt resistor R_{sh} and an internal comparator K1 with its reference voltage of typ. 49 mV (V_S = 12 V). The outage of one lamp out of two lamps is detected according to the following calculation:

Nominal current of 1 lamp: 21 W / (V_S = 12 V):

$$I_{\text{lamp}} = 1.75 \text{ A}$$

Nominal current of 2 lamps: 2 x 21 W / (V_S = 12 V):

$$I_{\text{lamp}} = 3.5 \text{ A.}$$

The detection threshold is recommended to be set in the middle of the current range: I_{outage} [2.7 A

Thus the shunt resistor is calculated as:

$$R_{\text{sh}} = V_T (K1) / I_{\text{outage}}$$

$$R_{\text{sh}} = 49 \text{ mV} / 2.7 \text{ A} = 18 \text{ mW.}$$

Comparator K1's reference voltage is matched to the characteristics of filament lamps (see "control signal threshold" in the data part).

The combination of shunt resistor and resistance of wire harness prevents Pin 7 from a too high voltage in the case of shorted lamps.

Pin 8, Start input

Start condition for flashing: the voltage at Pin 8 has to be below K3 threshold (flasher switch closed).

Humidity and dirt may decrease the resistance between 49 a and GND. If this leakage resistance is u 5 kW the IC is still kept in its off-condition. In this case the voltage at Pin 8 is between the thresholds of comparators K2 and K3.

During the bright phase the voltage at Pin 8 is above the K2 threshold, during the dark phase it is below the K3 threshold.

For proper start conditions a minimum lamp wattage of 1 W is required.

Absolute Maximum Ratings

Reference point Pin 1

Parameters	Symbol	Value	Unit
Supply voltage Pins 2 and 6	V_S	16,5	V
Surge forward current			
$t_p = 0.1$ ms Pins 2 and 6	I_{FSM}	1.5	A
$t_p = 300$ ms Pins 2 and 6		1.0	A
$t_p = 300$ ms Pin 8		50.0	mA
Output current Pin 3	I_O	0.3	A
Power dissipation			
$T_{amb} = 95_C$ DIP8	P_{tot}	420	mW
SO8		340	
$T_{amb} = 60_C$ DIP8		690	
SO8		560	
Junction temperature	T_j	150	$_C$
Ambient temperature range	T_{amb}	-40 to + 95	$_C$
Storage temperature range	T_{stg}	-55 to + 150	$_C$

Thermal Resistance

Parameters	Symbol	Value	Unit
Junction ambient DIP8	R_{thJA}	110	K/W
SO8	R_{thJA}	160	K/W

Electrical Characteristics

Typical values under normal operation in application circuit (see figure 1), V_S (+49, Pin 2 and 6) = 12 V.
Reference point ground (-31), $T_{amb} = 25^\circ C$, unless otherwise specified

Parameters	Test conditions / Pin	Symbol	Min.	Typ.	Max.	Unit
Supply voltage range	Pins 2 and 6	V_S	9		15	V
Supply current	Dark phase, Pins 2 and 6	I_S		4.5	8	mA
	Bright phase, Pins 2 and 6	I_S		7.0	11	mA
Relay control output	Pin 3					
Saturation voltage	$I_O = 150$ mA, $V_S = 9$ V	V_O			1.0	V
reverse current		I_O			0.1	mA
Start delay (Delay time)	First bright phase	t_{on}			10	ms
Frequency tolerance	Normal flashing	Δf_1	-5		+5	%
Bright period	Basic frequency f_1	Δf_1	47		53	%
	Control frequency f_2	Δf_2	37		45	%
Frequency increase	Lamp outage	f_2	2.15 f_1		2.3 f_1	Hz
Control signal threshold	$V_S = 15$ V Pin 7	$V_{(RS)}$	50	53	57	mV
	$V_S = 9$ V		43	45	47	
	$V_S = 12$ V		47	49	51	
Leakage resistance	49a to GND	R_P		4	5	kW
Lamp load		P_L	1			W

Package Information

Package DIP8

Dimensions in mm

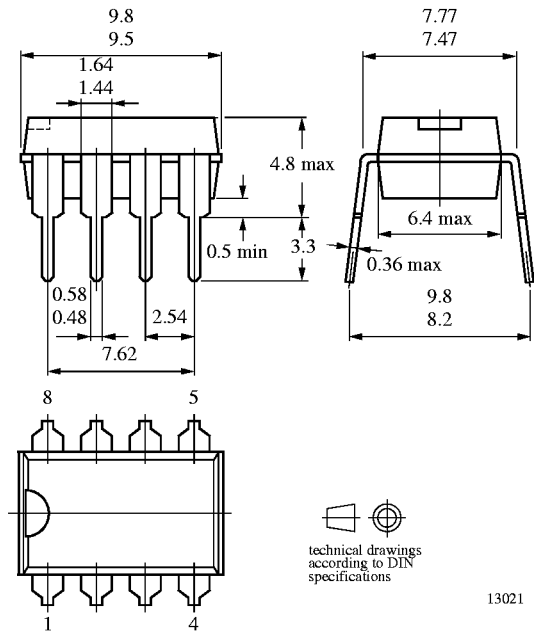

Package SO8

Dimensions in mm

