



54F/74F583 4-Bit BCD Adder

General Description

The 'F583 high-speed 4-bit, BCD full adder with internal carry lookahead accepts two 4-bit decimal numbers (A_0 – A_3 , B_0 – B_3) and a Carry Input (C_n). It generates the decimal sum outputs (S_0 – S_3), and a Carry Output (C_{n+4}) if the sum is greater than 9. The 'F583 is the functional equivalent of the 82S83.

Features

- Adds two decimal numbers
- Full internal lookahead
- Fast ripple carry for economical expansion
- Sum output delay time 16.5 ns max
- Ripple carry delay time 8.5 ns max
- Input to ripple delay time 14.0 ns max
- Supply current 60 mA max
- Available in SOIC, (300 mil only)

Ordering Code: See Section 5

Logic Symbols

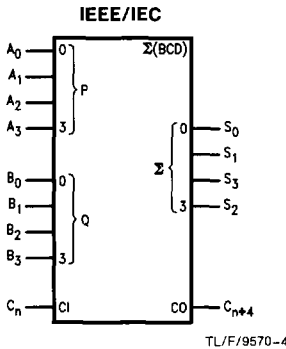
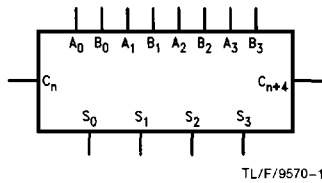

Connection Diagrams

**Pin Assignment for
DIP, SOIC and Flatpak**

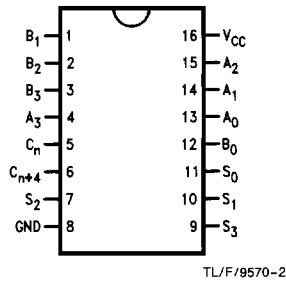

**Pin Assignment
for LCC**

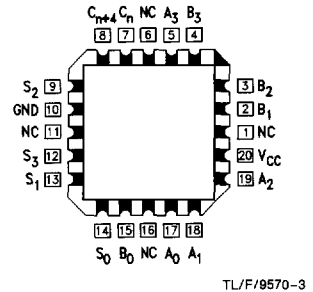

Unit Loading/Fan Out: See Section 2 for U.L. Definitions

Pin Names	Description	54F/74F	
		U.L. HIGH/LOW	Input I_{IH}/I_{IL} Output I_{OH}/I_{OL}
A_0 – A_3	A Operand Inputs	1.0/2.0	20 μ A/–1.2 mA
B_0 – B_3	B Operand Inputs	1.0/2.0	20 μ A/–1.2 mA
C_n	Carry Input	1.0/1.0	20 μ A/–0.6 mA
S_0 – S_3	Sum Outputs	50/33.3	–1 mA/20 mA
C_{n+4}	Carry Output	50/33.3	–1 mA/20 mA

Functional Description

The 'F583 4-bit binary coded (BCD) full adder performs the addition of two decimal numbers (A_0-A_3 , B_0-B_3). The look-ahead generates the BCD carry terms internally, allowing the 'F583 to then do BCD addition correctly. For BCD numbers 0 through 9 at A and B inputs, the BCD sum forms at the output. In the addition of two BCD numbers totalling a number greater than 9, a valid BCD number and a carry will result.

For input values larger than 9, the number is converted from binary to BCD. Binary to BCD conversion occurs by grounding one set of inputs, A_n or B_n , and applying any 4-bit binary number to the other set of inputs. If the input is between 0 and 9, a BCD number occurs at the output. If the binary input falls between 10 and 15, a carry term is generated. Both the carry term and the sum are the BCD equivalent of the binary input. Converting binary numbers greater than 16 may be achieved through cascading 'F583s.

Logic Diagram

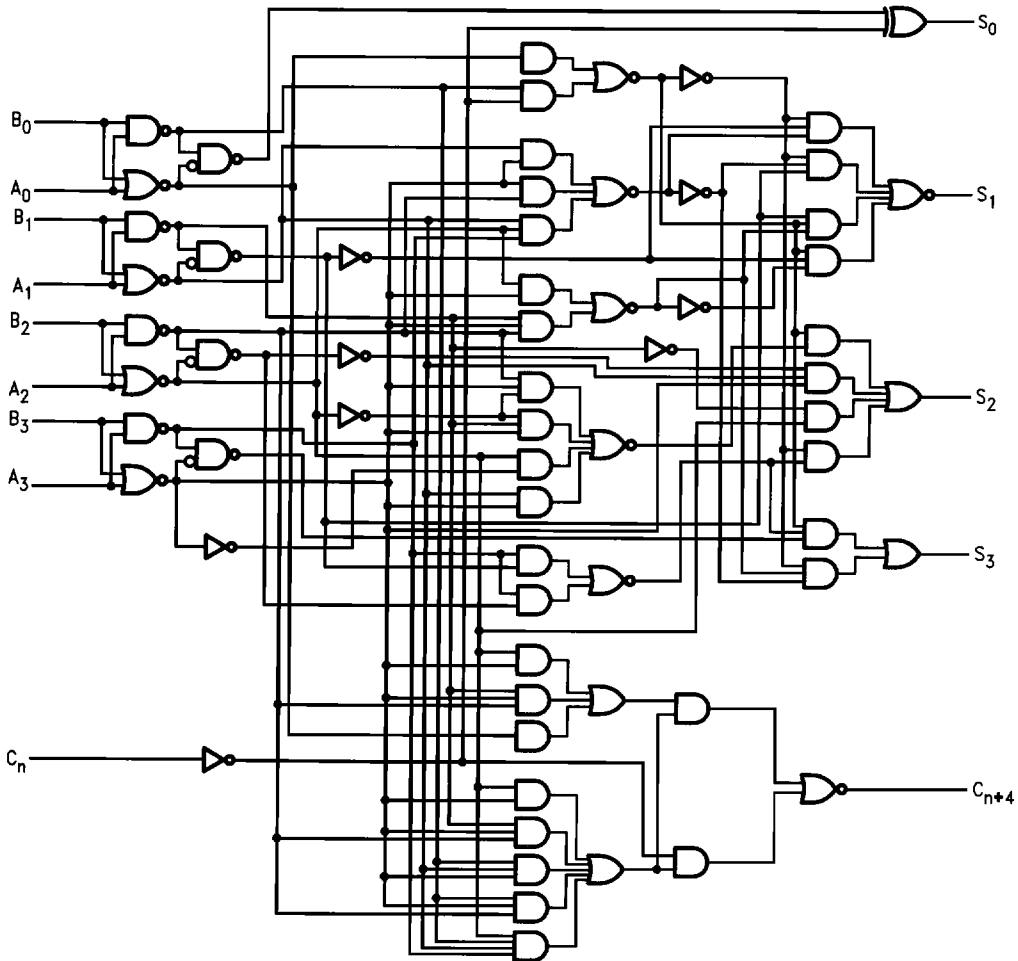

TL/F/9570-5

Please note that this diagram is provided only for the understanding of logic operations and should not be used to estimate propagation delays.

Absolute Maximum Ratings (Note 1)

If Military/Aerospace specified devices are required, please contact the National Semiconductor Sales Office/Distributors for availability and specifications.

Storage Temperature	-65°C to +150°C
Ambient Temperature under Bias	-55°C to +125°C
Junction Temperature under Bias	-55°C to +175°C
V _{CC} Pin Potential to Ground Pin	-0.5V to +7.0V
Input Voltage (Note 2)	-0.5V to +7.0V
Input Current (Note 2)	-30 mA to +5.0 mA
Voltage Applied to Output in HIGH State (with V _{CC} = 0V)	
Standard Output	-0.5V to V _{CC}
TRI-STATE® Output	-0.5V to +5.5V
Current Applied to Output in LOW State (Max)	twice the rated I _{OL} (mA)

Note 1: Absolute maximum ratings are values beyond which the device may be damaged or have its useful life impaired. Functional operation under these conditions is not implied.

Note 2: Either voltage limit or current limit is sufficient to protect inputs.

Recommended Operating Conditions

Free Air Ambient Temperature	-55°C to +125°C
Military	
Commercial	0°C to +70°C
Supply Voltage	
Military	+4.5V to +5.5V
Commercial	+4.5V to +5.5V

DC Electrical Characteristics

Symbol	Parameter	54F/74F			Units	V _{CC}	Conditions
		Min	Typ	Max			
V _{IH}	Input HIGH Voltage	2.0			V		Recognized as a HIGH Signal
V _{IL}	Input LOW Voltage			0.8	V		Recognized as a LOW Signal
V _{CD}	Input Clamp Diode Voltage			-1.2	V	Min	I _{IN} = -18 mA
V _{OH}	Output HIGH Voltage	54F 10% V _{CC} 74F 10% V _{CC} 74F 5% V _{CC}	2.5 2.5 2.7		V	Min	I _{OH} = -1 mA I _{OH} = -1 mA I _{OH} = -1 mA
V _{OL}	Output LOW Voltage	54F 10% V _{CC} 74F 10% V _{CC}		0.5 0.5	V	Min	I _{OL} = 20 mA I _{OL} = 20 mA
I _{IH}	Input HIGH Current			20	μA	Max	V _{IN} = 2.7V
I _{BVI}	Input HIGH Current Breakdown Test			100	μA	Max	V _{IN} = 7.0V
I _{IL}	Input LOW Current			-0.6 -1.2	mA	Max	V _{IN} = 0.5V (C _n) V _{IN} = 0.5V (A _n , B _n)
I _{OS}	Output Short-Circuit Current		-60	-150	mA	Max	V _{OUT} = 0V
I _{CEX}	Output HIGH Leakage Current			250	μA	Max	V _{OUT} = V _{CC}
I _{CCL}	Power Supply Current		40	60	mA	Max	V _O = LOW

AC Electrical Characteristics: See Section 2 for Waveforms and Load Configurations

Symbol	Parameter	74F			54F		74F		Units	Fig. No.
		T _A = +25°C V _{CC} = +5.0V C _L = 50 pF			T _A , V _{CC} = Mil C _L = 50 pF		T _A , V _{CC} = Com C _L = 50 pF			
		Min	Typ	Max	Min	Max	Min	Max		
t _{PLH} t _{PHL}	Propagation Delay A _n or B _n to S _n	2.5 2.5	13.0 11.0	16.5 14.0	2.5 2.5	20.5 19.0	2.5 2.5	17.5 15.0	ns	2-3
t _{PLH} t _{PHL}	Propagation Delay C _n to C _{n+4}	2.5 2.5	6.5 5.0	8.5 6.5	2.5 2.5	10.5 8.5	2.5 2.5	9.5 7.5	ns	2-3
t _{PLH} t _{PHL}	Propagation Delay A _n or B _n to C _{n+4}	4.0 4.0	11.0 8.0	14.0 10.5	4.0 4.0	19.5 13.5	4.0 4.0	15.0 11.5	ns	2-3