

**8-CHANNEL, 12-BIT,  
 75kHz DATA ACQUISITION SYSTEM**

**FEATURES**

- Multiplexer, sample-and-hold, A/D in a compact 28-pin DIP
- Input overvoltage protection
- 75 kHz system throughput
- Three state output buffer
- Pin for pin compatible with HS9410 Series

**DESCRIPTION**

The SP9415 Series is a complete 8-channel, microprocessor compatible, 12-bit data acquisition system with all the interface logic to connect directly to 8-or 16-bit microprocessor buses. Packaged in a ceramic, 28-pin DIP, the SP9415 Series includes an 8-channel multiplexer, 1 microsecond sample-and-hold-amplifier and a 15 microsecond, 12-bit A/D converter. Pin for pin compatible with the popular HS9410 Series, the SP9415 Series offers faster acquisition time, A/D conversion time and system throughput.

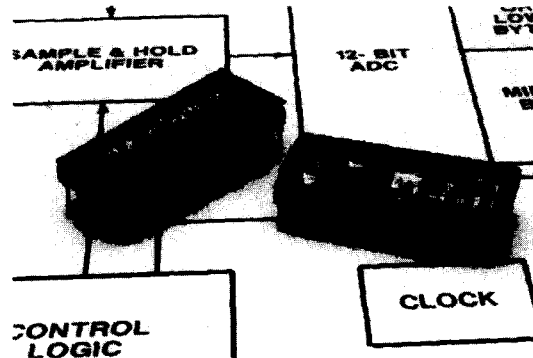

To take advantage of the 28-pin package the user must specify an input range of 0 to +10V,  $\pm 5V$  or  $\pm 10V$  when ordering. Four basic product grades are available; J and K models are specified over a temperature range of 0°C to +70°C while the S and T models are specified over an extended temperature range of -55°C to +125°C. Full screening to MIL-STD-883C is available.

**FUNCTIONAL DIAGRAM**

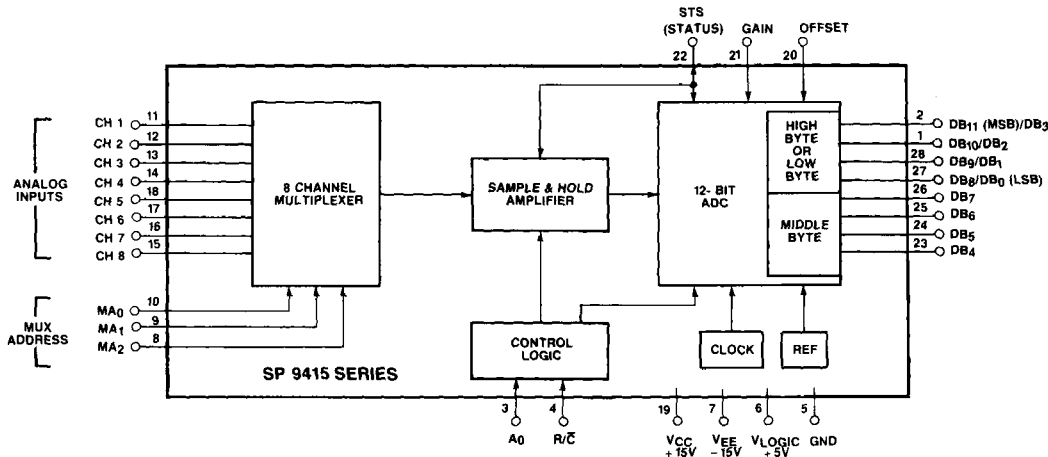

**11**

# SPECIFICATIONS

(Typical @ +25°C with  $V_{CC} = +15V$ ,  $V_{EE} = -15V$ ,  $V_{LOGIC} = +5V$ , unless otherwise specified.)

MODEL	SP 941XJ	SP 941XK	SP 941XS	SP 941XT
<b>TRANSFER CHARACTERISTICS</b>				
Resolution	12-Bits	*	*	*
Number of Channels	8 Single-Ended	*	*	*
Throughput Rate	75 kHz typ, 60 kHz min	*	*	*
<b>ANALOG INPUTS</b>				
Input Ranges <sup>1</sup> (Specified as a suffix in the model number. See Ordering Guide.)				
SP 9415	0 to +10V	*	*	*
SP 9416	± 5V	*	*	*
SP 9417	± 10V	*	*	*
Input Bias Current per Channel				
$I_B$ 25°C	± 10nA	*	*	*
-55°C to +125°C			± 250nA max	*
Input Impedance				
ON Channel	5MΩ    25pF	*	*	*
OFF Channel	5MΩ    5pF	*	*	*
<b>DIGITAL INPUTS</b>				
Logic Inputs				
R/C, $A_O$				
$V_{IH}$	+ 2.4V min	*	*	*
$V_{IH}$	+ 5.5V max	*	*	*
$V_{IL}$	+ 0.8V max	*	*	*
$V_{IL}$	- 0.5V min	*	*	*
$I_{IH}$	± 5μA max	*	*	*
$I_{IH}$	± 5μA max	*	*	*
Multiplexer Inputs				
$V_{IH}$	+ 0.8V max	*	*	*
$V_{IH}$	+ 4.0V max <sup>2</sup>	*	*	*
Input Capacitance (All Digital Inputs)	5pF typ	*	*	*
Minimum Start Pulse				
R/C-Negative	50ns	*	*	*
<b>SIGNAL DYNAMICS</b>				
Acquisition Time (20V Step)				
0.1%	0.8μsec typ, 1.2μsec max	*	*	*
0.01%	1.0μsec typ, 1.5μsec max	*	*	*
Conversion Time				
12-Bit Conversion	12μs typ, 15μs max	*	*	*
8-Bit Conversion	8μs typ, 12μs max	*	*	*
<b>DIGITAL OUTPUTS</b>				
Logic Outputs				
$DB_{11}$ - $DB_0$ STS				
Logic 0	+ 0.4V max, $I_{OL} = 1.6mA$	*	*	*
Logic 1	+ 2.4V min, $I_{OH} = 0.5mA$	*	*	*
Leakage (High Z State)	± 5μA typ ( $DB_{11}$ - $DB_0$ only)	*	*	*
Capacitance	5pF typ	*	*	*
Output Code Configuration				
Unipolar	Positive True Binary	*	*	*
Bipolar	Positive True Offset Binary	*	*	*
<b>POWER SUPPLY</b>				
$V_{IOXX}$	+ 4.5 to + 5.5 Volts @ 5mA max	*	*	*
$V_{CC}$	+ 13.5 to + 16.5 Volts @ 25mA max	*	*	*
$V_{EE}$	- 13.5 to - 16.5 Volts @ 10mA max	*	*	*
Power Dissipation	550mW typ.	*	*	*
Rejection <sup>3</sup>				
$V_{LOGIC}$	0.002%/° typ, 0.005%/° max	*	*	*
$V_{CC}$	0.002%/° typ, 0.005%/° max	*	*	*
$V_{EE}$	0.002%/° typ, 0.005%/° max	*	*	*
<b>ACCURACY</b>				
Linearity Error (% of F.S.R. max)	± 0.025	± 0.012	± 0.025	± 0.012
Offset <sup>4</sup>				
Unipolar (% of F.S.R.)	± 0.05 typ, ± 0.1 max	*	*	*
Bipolar (% of F.S.R. max)	± 0.25	± 0.1	± 0.25	± 0.1
Gain <sup>4</sup> (% to F.S.R. max)	± 0.3	*	*	*
<b>STABILITY</b>				
Linearity (ppm/°C max)	± 0.5	± 0.5	± 2.5	± 2.5
Unipolar Offset (ppm/°C max)	± 10	± 5	± 25	± 20
Bipolar Offset (ppm/°C max)	± 25	± 20	± 25	± 20
Gain (Scale Factor)(ppm/°C max)	± 50	± 20	± 50	± 25
<b>TEMPERATURE RANGE</b>				
Operating	0° to + 70°C	*	- 55°C to + 125°C	- 55°C to + 125°C
Storage	- 25°C to + 85°C	*	- 65°C to + 150°C	- 55°C to + 125°C

## NOTES:

1. All models input may exceed supply voltages up to  $70V_{IO}$  without permanent damage to device. 2. 1K pullup to +5V recommended for  $MA_0$ - $MA_2$  when driven by TTL. 3. Maximum change over rated supply voltage. 4. Externally adjustable to zero. See Applications Information.

\*Specifications same as SP 9415J.

## PACKAGE OUTLINE

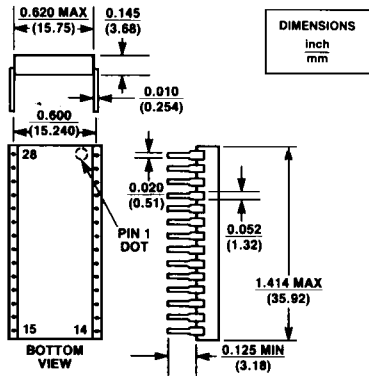

## PIN ASSIGNMENTS

PIN	FUNCTION	PIN	FUNCTION
1	DB <sub>10</sub> /DB <sub>2</sub>	28	DB <sub>9</sub> /DB <sub>1</sub>
2	DB <sub>11</sub> (MSB)/DB <sub>3</sub>	27	DB <sub>8</sub> /DB <sub>0</sub>
3	A <sub>0</sub>	26	DB <sub>7</sub>
4	R/C	25	DB <sub>6</sub>
5	GROUND	24	DB <sub>5</sub>
6	V <sub>LOGIC</sub>	23	DB <sub>4</sub>
7	V <sub>EE</sub>	22	STS(STATUS)
8	MUX ADDRESS A <sub>2</sub>	21	GAIN
9	MUX ADDRESS A <sub>1</sub>	20	OFFSET
10	MUX ADDRESS A <sub>0</sub>	19	V <sub>CC</sub>
11	INPUT CH 1	18	INPUT CH 5
12	INPUT CH 2	17	INPUT CH 6
13	INPUT CH 3	16	INPUT CH 7
14	INPUT CH 4	15	INPUT CH 8

## ABSOLUTE MAXIMUM RATINGS

V <sub>CC</sub> to Common GND	0 to + 16.5V
V <sub>EE</sub> to Common GND	0 to - 16.5V
V <sub>LOGIC</sub> to Common GND	0 to + 7V
Control Inputs (A <sub>0</sub> , R/C) to Common GND	- 0.5V to V <sub>LOGIC</sub> + 0.5V
Power Dissipation	1.6W
Lead Temperature, Soldering	300°C, 10Sec
Maximum Input Voltage	V <sub>CC</sub> + 20V
Minimum Input Voltage	V <sub>EE</sub> - 20V
Analog Input Maximum Current	25mA

## CONTROL FUNCTIONS

The SP 9415 Series contains control functions necessary to provide for microprocessor interface. All control functions are defined in Tables 1, 2, and 3.

Function	Definition	Function
R/C	Read/Convert	<ol style="list-style-type: none"> <li>1. <math>\bar{1}</math> initiates conversion.</li> <li>2. Low (0) disconnects data bus.</li> <li>3. High (1) initiates read.</li> </ol>
A <sub>0</sub>	Device Address	<ol style="list-style-type: none"> <li>1. Selects conversion mode. 12-bits if low (0), 8-bits if high (1) when R/C <math>\bar{1}</math>.</li> <li>2. In read mode A<sub>0</sub> selects the output format. If low (0) then 8 MSB's (high and middle byte) or if high (1) then only low byte and trailing zeroes.</li> </ol>
MA <sub>0</sub> MA <sub>1</sub> MA <sub>2</sub>	Multiplexer Address	Select Channels 1-8 (see MUX Logic Table 3)

Table 1. Defining the Control Functions

Control Inputs		Operation
R/C	A <sub>0</sub>	
$\bar{1}$	0	Initiates 12-bit conversion
$\bar{1}$	1	Initiates 8-bit conversion
1	0	Enables 8 MSB's (high byte)
1	1	Enables 4 LSB's (low byte) and 4 trailing zeros
0	X	Output data (DB) goes to high impedance state.

Table 2. Truth Table—Control Inputs

Mux Address Inputs			Channel Selected
A <sub>2</sub>	A <sub>1</sub>	A <sub>0</sub>	
0	0	0	1
0	0	1	2
0	1	0	3
0	1	1	4
1	0	0	5
1	0	1	6
1	1	0	7
1	1	1	8

### NOTES:

- 1 indicates logic HIGH.
- 0 indicates logic LOW.
- X indicates don't care.
- $\bar{1}$  indicates operation commence on high to low transition.
- MSB → XXXX    XXXX  
High Byte    Middle Byte
- XXXX ← LSB  
Low Byte

Table 3. Truth Table—Multiplexer Address

11

# APPLICATIONS INFORMATION

## TIMING

The timing diagrams are shown in Figures 1 through 6. Figures 1 and 2 show how the multiplexer addressing is related to the convert cycle, while Figures 3 and 4 show the timing sequence to start either a 12- or an 8-bit conversion. Figures 5 and 6 show how to read the multiplexed data from the internal register in the SP 9415.

### Figures 1 and 2

The multiplexer address can be changed either during or after a conversion, but care must be taken not to change the address within 1 microsecond after the convert command to insure that the sample/hold will not start to acquire the signal of the new channel. After the multiplexer address has been changed, you must allow the sample/hold at least 1.5 microseconds in **sample mode** to acquire the new input signal.

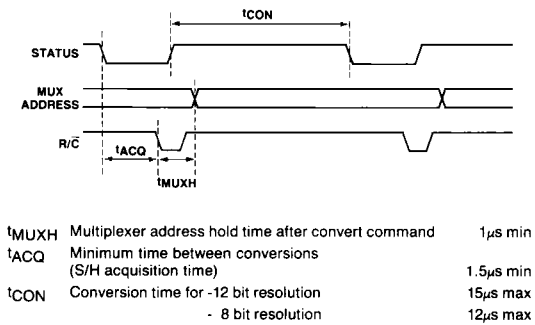

Figure 1. Timing Diagram 8/12-Bit Conversion, MUX Address Changes During Conversion

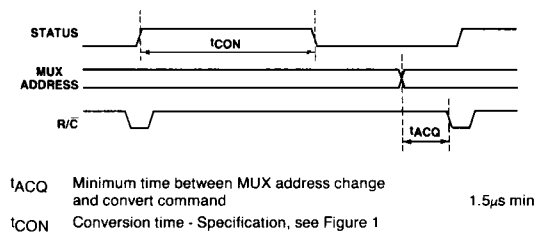

Figure 2. Timing Diagram 8/12-Bit Conversion, MUX Address Changes Between Conversions

### Figures 3 and 4

Figures 3 and 4 show how to start a convert cycle. The logic level of the  $A_0$  line determines whether a 12- or 8-bit conversion will be initiated. If  $A_0$  is low during the start convert command, a 12 bit conversion will be started; if  $A_0$  is high, an 8-bit conversion will occur. The  $A_0$  line has to be setup when the R/C line goes to logic '0' and must remain in the desired level for at least 50 ns. The R/C line is used both to start a conversion and to read the output data. If R/C is going low a con-

version is initiated. This is indicated by the STATUS line going high. A second start convert command during a conversion will be ignored. The R/C pulse must have a minimum width of 50 ns. For optimum performance the rising edge of the R/C pulse should not occur during a conversion if the conversion has been in progress for more than 1 microsecond, i.e., the negative R/C pulse should be either shorter than 1 microsecond or longer than the conversion time.

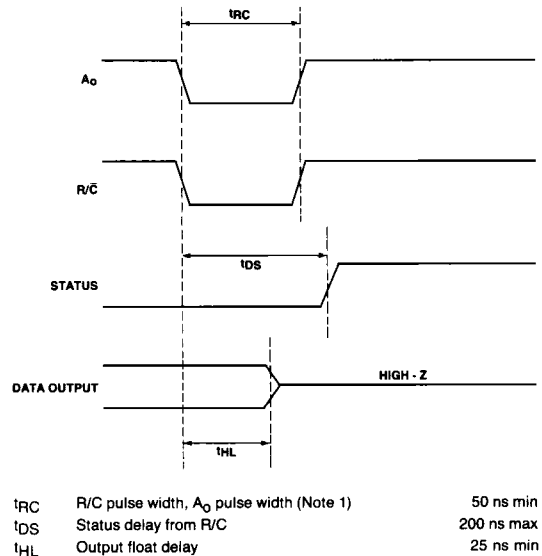

Figure 3. Timing Diagram to Start a 12-Bit Conversion

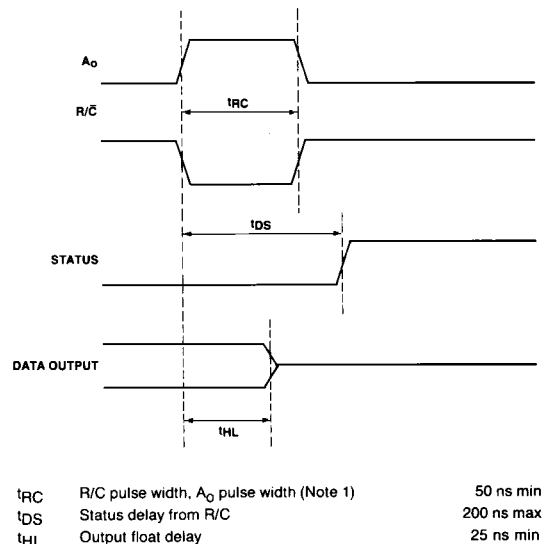
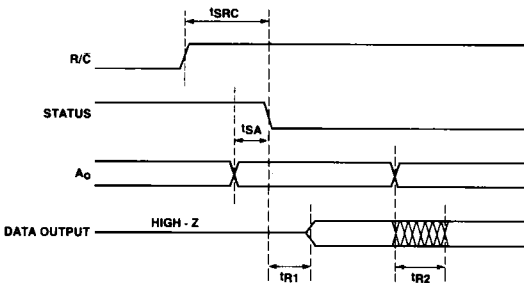

Figure 4. Timing Diagram to Start an 8-Bit Conversion

## Figures 5 and 6

If a conversion is in progress the data output lines are disabled and in the high-impedance state. Data can be enabled by bringing the R/C line high after a conversion is complete (this is indicated by the STATUS line going low; Fig. 6). If R/C has been returned high during a conversion the data outputs will be enabled automatically after STATUS goes low (Fig. 5). The  $A_0$  line is used to address either the 8 upper data bits or the 4 lower data bits followed by 4 trailing zeros. If an 8-bit conversion has been performed the lower 4 bits will always be '0'. After an 8-bit conversion, it is not necessary to read the lower 4 bits prior to starting a new conversion. Note that  $A_0$  only controls the address of the two data bytes while the high impedance state of the output buffers is controlled by the R/C and STATUS line. The output buffers will not return to the high impedance state when  $A_0$  is changed to address the second data byte.



$t_{SRC}$	R/C set-up time prior to status going low	0 ns min
$t_{SA}$	$A_0$ set-up time prior to status going low (Note 2)	50 ns min
$t_{R1}$	Access time, 1st data byte (from status)	125 ns max
$t_{R2}$	Access time, 2nd data byte (from $A_0$ )	225 ns max

Figure 5. Timing Diagram Read Cycle, R/C Going High During Conversion

### NOTES:

- For optimum performance the positive edge of the R/C pulse should occur during a conversion if the conversion has been started for more than 4.5 microseconds. The negative R/C pulse should be longer than 4.5 microseconds before the STATUS goes high.
- If the set-up time for  $A_0$  cannot be met, the access time for the first data byte will be increased. In that case the first data byte will become valid 225 ns max after the change of the  $A_0$  line.

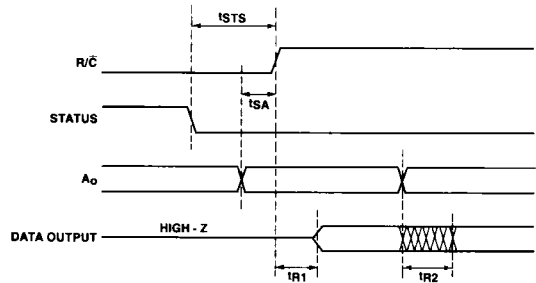

$t_{STS}$	Status going low prior to R/C going high	0 ns min
$t_{SA}$	$A_0$ set-up time prior to R/C going high (Note 2)	50 ns min
$t_{R1}$	Access time, 1st data byte (from R/C)	125 ns max
$t_{R2}$	Access time, 2nd data byte (from $A_0$ )	225 ns max

Figure 6. Timing Diagram Read Cycle, R/C Going High After Conversion

## USING THE $A_0$ LINE

The state of  $A_0$  at the start of a conversion places the DAS in either a full 12-bit conversion or in an 8-bit 'short cycle' mode. During a READ at the end of a conversion  $A_0$  is used to format the data as follows:

### 1. Prior to Conversion (WRITE)

$A_0 = 1$   
 $A_0 = 0$

### MODE

Short cycle 8-bit conversion  
Full 12-bit conversion

### 2. After Conversion (READ)

$A_0 = 1$   
 $A_0 = 0$

Data = Low Byte (LSB)  
followed by zeros  
Data = High Byte (MSB's)  
followed by middle byte.

In a  $\mu P$  application  $A_0$  can be considered a pair of W/R locations as follows:

### 1. Prior to Conversion (WRITE)

$\overline{W/R} = 0$  in low address ( $A_0 = 0$ )  
 $\overline{W/R} = 0$  in high address ( $A_0 = 1$ )

### MODE

Full 12-bit conversion  
Short cycle 8-bit conversion

### 2. After Conversion (READ)

$\overline{W/R} = 1$  in high address ( $A_0 = 1$ )  
 $\overline{W/R} = 1$  in low address ( $A_0 = 0$ )

LSB's & zeros  
8 MSB's only

## MICROPROCESSOR INTERFACE

The SP 9415 Series DAS can be interfaced with most popular 8-bit microprocessors. The DAS may be either positioned in a memory location (memory map) or as an I/O device. In the case of memory mapping, the DAS acts as a static RAM where READ and WRITE instructions are given to the selected address. When the DAS is connected as an I/O device, the I/O enable can be substituted for the MEMR or MEMW command. Figure 7 shows a typical scheme to implement this interface.

STS is not used in this example; the  $\mu P$  must read data 15 $\mu s$  after conversion starts. This delay can be generated with NOP or other instructions inserted between the WRITE and READ functions. The STS line can also be used to cause the processor to WAIT or HALT or can be used as an interrupt line such as IREQ (in the case of 6800 or 6502).

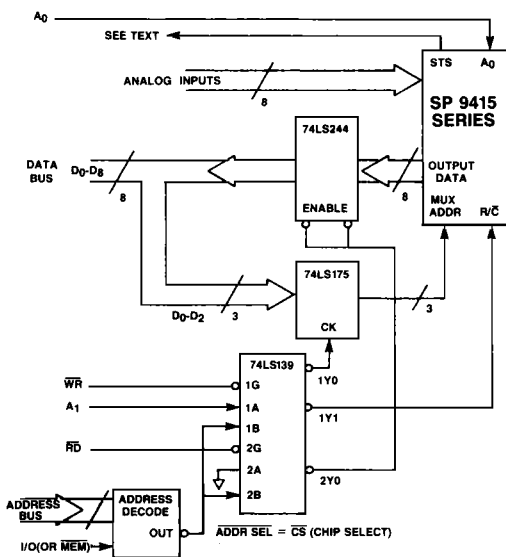

					SP 9415 FUNCTION	
A <sub>0</sub>	A <sub>1</sub>	WR	RD	ADDR SEL	Read/Write	Operation
X	0		1	0	WRITE	MUX ADDRESS
0	1		1	0	WRITE	START 12-BIT CONV.
1	1		1	0	WRITE	START 8-BIT CONV.
0	X	1	0	0	READ	HIGH BYTE (8 MSB's)
1	X	1	0	0	READ	LOW BYTE (4 LSB's)

### NOTE:

- 1 indicates logic HIGH.
- 0 indicates logic LOW.
- X indicates don't care.
- indicates operation commences on low to high transition.
- indicates operation commences on high to low transition.

## INPUT EXPANSION

The DAS is configured with an 8 channel high level multiplexer input. This was done to optimize package size (28 pin DIP) and cost. In the event the user wishes to increase the number of input channels, a double rank MUX input is recommended (series connected). This typical configuration is shown in Figure 8.

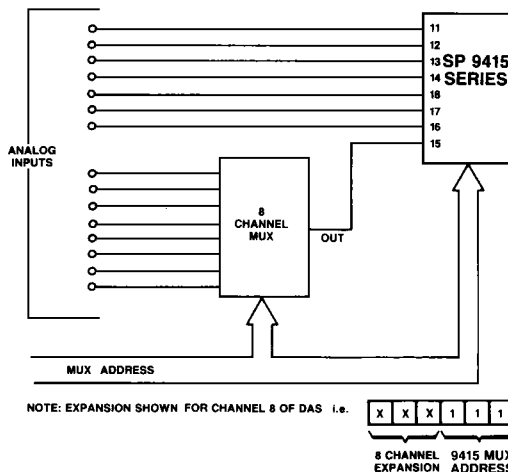

## ZERO AND GAIN CONNECTIONS

The DAS is normally used with external zero and gain calibration potentiometers. However, if maximum accuracy is not required, they may be omitted. The zero control has a range of about  $\pm 20$ LSB, and the gain control has a range of about  $\pm 13$ LSB.

Proper gain and zero calibration requires great care and the use of extremely sensitive and accurate instruments. The voltage source used as a signal input must be very stable. It also should be capable of being set to within 1/10LSB at both ends of its range.

The DAS's zero and gain adjustments are independent of each other if the zero (or offset) adjustment is made first.

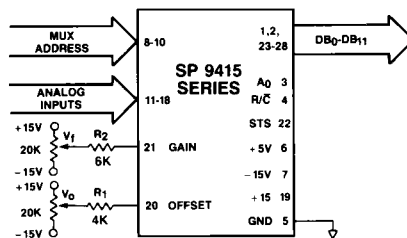

## ZERO ADJUSTMENT PROCEDURE

1. For unipolar ranges:
  - a) Set input voltage precisely to  $+1/2$ LSB.
  - b) Adjust zero control until converter is switching from 000000000000 to 000000000001.
2. For bipolar ranges:
  - a) Set input voltage precisely to  $1/2$ LSB above  $-F.S.$
  - b) Adjust zero control until converter is switching from 000000000000 to 000000000001
3. When zero adjust is not performed pin 20 should be a no connect.

## GAIN ADJUSTMENT PROCEDURE

1. Set input voltage precisely to  $1/2$ LSB less than 'all bits on' value. Note that this is  $1 1/2$ LSB less than nominal full scale.
2. Adjust gain control until converter is switching from 111111111110 to 111111111111.
3. When gain adjust is not performed pin 20 should be a no connect.

Table 4 summarizes the zero and gain adjustment procedure, and shows the proper input test voltages used in calibrating the DAS.

Input Voltage Range	Adjustment	Input Voltage	Adjust input to point where converter is just on the verge of switching between the two codes shown. <sup>1</sup>
0 to +10V	ZERO GAIN	1.22mV 9.9963V	0000 0000 0000 1111 1111 1110
$\pm 5V$	ZERO GAIN	-4.9988V 4.9963V	0000 0000 0000 1111 1111 1110
$\pm 10V$	ZERO GAIN	-9.9976V 9.9927V	0000 0000 0000 1111 1111 1110

<sup>1</sup>Codes shown are natural binary for unipolar input ranges and offset binary for bipolar ranges

0 = transition between logic "1" and logic "0" state. All gain, offset and linearity measurements are performed using the transition test method.

Table 4. Calibration Data

## POWER SUPPLY CONSIDERATION

Power supplies used for the DAS should be selected for low noise operation. In particular they should be free of high frequency noise. Unstable output codes may result with noisy power sources. It is important to remember that 2.44mV is 1LSB for a 10 volt input.

Decoupling capacitors are recommended on all power supply pins located as close to the converter as possible. Suitable decoupling capacitors are 10 $\mu$ F tantalum type in parallel with 0.1 $\mu$ F disc ceramic type.

## GROUNDING CONSIDERATIONS

The common at pin 5 is the ground reference point for the internal reference and is thus the high quality ground for the DAS. In order to achieve all of the high accuracy performance available from the DAS in an environment of high digital noise content, care should be taken when handling analog and digital grounds, as follows. Where analog and digital grounds are run separately on the PCB, these should be connected together at the package (pin 5). However, if the grounds are connected separately in the system for other reasons, then only the analog ground should be connected at the package to pin 5. If digital common contains high frequency noise beyond 200mV, this noise may feed through the converter, so that some caution will be required.

It is also important in the layout to carefully consider the placement of digital lines. It is recommended that digital lines not be run directly under the DAS. For optimum system performance, if space permits, a ground plane is advised under the DAS. This should be connected to a digital ground. Finally, in packaging the assembled DAS, the designer should also try to minimize any capacitive coupling that might occur at the top to the device.

## ORDERING INFORMATION

Model Number <sup>1</sup>	Input Range	System Accuracy (% FSR)	Full Scale T.C. (ppm/°C)	Temp. Range	MIL Screening
SP 94XXJ	SEE NOTE 1	± 0.025	50.0	0°C to +70°C	—
SP 94XXK		± 0.012	20.0	0°C to +70°C	—
SP 94XXS		± 0.025	50.0	-55°C to +125°C	—
SP 94XXT		± 0.012	25.0	-55°C to +125°C	—
SP 94XXS/B		± 0.025	50.0	-55°C to +125°C	883C
SP 94XXT/B		± 0.012	25.0	-55°C to +125°C	883C

### NOTES:

1. SP 94XX

MODEL SUFFIX	INPUT RANGE
15	0 to +10V
16	± 5V
17	± 10V

Add letter suffix as required above.

Specifications subject to change without notice.

**CAUTION:** ESD (Electro-Static Discharge) sensitive device. Permanent damage may occur when unconnected devices are subjected to high energy electro-static fields. Unused devices must be stored in conductive foam or shunts. Protective foam should be discharged to the destination socket before devices are removed. Devices should be handled at static safe workstations only. Unused digital inputs must be grounded or tied to the logic supply voltage. Voltage at any digital input should never exceed the supply voltage by more than 0.5 volts or go below -0.5 volts. If this condition cannot be maintained, limit input current on digital inputs by using series resistors or contact Hybrid Systems for technical assistance. Unused analog input channels should be tied to ground. If the gain and offset circuitry is not used, pins 20 and 21 should be floating with no "antenna" type runs attached, and if possible be surrounded by a ground plane. Unused digital inputs should be tied to ground 0V to +5V.